



# JHW5N60

## 主要参数 MAIN CHARACTERISTICS

$I_D$ .....	(") A
$V_{DSS}$	600 V
$R_{dson}(@V_{gs}=10V)$	2.5 $\Omega$
$Q_g$	27 nC

### 用途

- 高频开关电源
- 电子镇流器
- UPS 电源

### 产品特性

- 低栅极电荷
- 低  $C_{rss}$  (典型值 14pF)
- 开关速度快
- 产品全部经过雪崩测试
- 高抗 dv/dt 能力
- RoHS 产品

### APPLICATIONS

- High efficiency switch mode power supplies
- Electronic lamp ballasts based on half bridge
- UPS

### FEATURES

- Low gate charge
- Low  $C_{rss}$  (typical 14pF)
- Fast switching
- 100% avalanche tested
- Improved dv/dt capability
- RoHS product

## 封装 Package

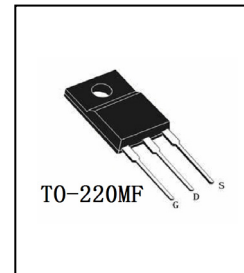
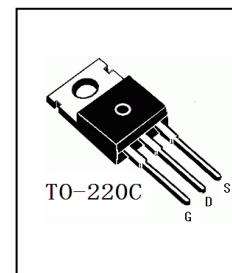
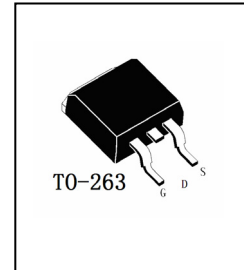
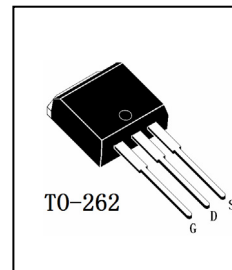
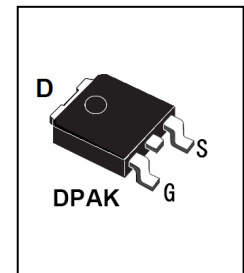
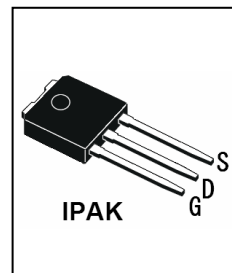
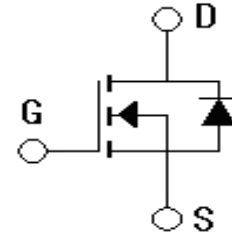

## 订货信息 ORDER MESSAGE

订货型号 Order codes	印记 Marking	封装 Package	无卤素 Halogen Free	包装 Packaging	器件重量 Device Weight
JHW5N60V-O-V-N-B	JHW5N60V	IPAK	否 NO	条管 Tube	0.35 g(typ)
JHW5N60R-O-R-N-B	JHW5N60R	DPAK	否 NO	条管 Tube	0.30 g(typ)
JHW5N60S-O-S-N-B	JHW5N60S	TO-263	否 NO	条管 Tube	1.37 g(typ)
JHW5N60B-O-B-N-B	JHW5N60B	TO-262	否 NO	条管 Tube	1.71 g(typ)
JHW5N60C-O-C-N-B	JHW5N60C	TO-220C	否 NO	条管 Tube	2.15 g(typ)
JHW5N60F-O-F-N-B	JHW5N60F	TO-220MF	否 NO	条管 Tube	2.20 g(typ)

**绝对最大额定值 ABSOLUTE RATINGS (Tc=25℃)**

项 目 Parameter	符 号 Symbol	数 值 Value			单 位 Unit
		JHW5N60V/R	JHW5N60S/B/C	JHW5N60F	
最高漏极-源极直流电压 Drain-Source Voltage	V <sub>DSS</sub>	600			V
连续漏极电流 Drain Current -continuous	I <sub>D</sub> T=25℃ T=100℃	4.5		4.5*	A
		2.6		2.6*	A
最大脉冲漏极电流 (注1) Drain Current - pulse (note 1)	I <sub>DM</sub>	18		18*	A
最高栅源电压 Gate-Source Voltage	V <sub>GSS</sub>	±30			V
单脉冲雪崩能量 (注2) Single Pulsed Avalanche Energy note 2)	E <sub>AS</sub>	210			mJ
雪崩电流 (注1) Avalanche Current (note 1)	I <sub>AR</sub>	4.5			A
重复雪崩能量 (注1) Repetitive Avalanche Current (note 1)	E <sub>AR</sub>	10.0			mJ
二极管反向恢复最大电压变化 速率 (注3) Peak Diode Recovery dv/dt (note 3)	dv/dt	4.5			V/ns
耗散功率 Power Dissipation	P <sub>D</sub> T <sub>C</sub> =25℃ -Derate above 25℃	51	100	33	W
		0.39	0.80	0.26	W/ ℃
最高结温及存储温度 Operating and Storage Temperature Range	T <sub>J</sub> , T <sub>STG</sub>	-55~+150			℃
引线最高焊接温度 Maximum Lead Temperature for Soldering Purposes	T <sub>L</sub>	300			℃

\*漏极电流由最高结温限制

\*Drain current limited by maximum junction temperature

**电特性 ELECTRICAL CHARACTERISTICS**

项 目 Parameter	符 号 Symbol	测试条件 Tests conditions	最小 Min	典型 Typ	最大 Max	单 位 Units
<b>关态特性 Off –Characteristics</b>						
漏—源击穿电压 Drain-Source Voltage	$BV_{DSS}$	$I_D=250\mu A, V_{GS}=0V$	600	-	-	V
击穿电压温度特性 Breakdown Voltage Temperature Coefficient	$\Delta BV_{DSS}/\Delta T_J$	$I_D=250\mu A$ , referenced to $25^\circ C$	-	0.65	-	V/ $^\circ C$
零栅压下漏极漏电流 Zero Gate Voltage Drain Current	$I_{DSS}$	$V_{DS}=600V, V_{GS}=0V,$ $T_C=25^\circ C$	-	-	10	$\mu A$
		$V_{DS}=480V, T_C=125^\circ C$	-	-	100	$\mu A$
正向栅极体漏电流 Gate-body leakage current, forward	$I_{GSSF}$	$V_{DS}=0V, V_{GS}=30V$	-	-	100	nA
反向栅极体漏电流 Gate-body leakage current, reverse	$I_{GSSR}$	$V_{DS}=0V, V_{GS}=-30V$	-	-	-100	nA
<b>通态特性 On-Characteristics</b>						
阈值电压 Gate Threshold Voltage	$V_{GS(th)}$	$V_{DS} = V_{GS}, I_D=250\mu A$	2.0	-	4.0	V
静态导通电阻 Static Drain-Source On-Resistance	$R_{DS(ON)}$	$V_{GS} = 10V, I_D=2A$	-	2.0	2.5	$\Omega$
正向跨导 Forward Transconductance	$g_{fs}$	$V_{DS} = 40V, I_D=2A$ (note 4)	-	4.7	-	S
<b>动态特性 Dynamic Characteristics</b>						
输入电容 Input capacitance	$C_{iss}$	$V_{DS}=25V,$ $V_{GS}=0V,$ $f=1.0MHz$	-	710	920	pF
输出电容 Output capacitance	$C_{oss}$		-	65	85	pF
反向传输电容 Reverse transfer capacitance	$C_{rss}$		-	14	19	pF

**电特性 ELECTRICAL CHARACTERISTICS**

开关特性 Switching Characteristics						
延迟时间 Turn-On delay time	$t_{d(on)}$	$V_{DD}=300V, I_D=4.5A, R_G=25\Omega$ (note 4, 5)	-	20	50	ns
上升时间 Turn-On rise time	$t_r$		-	55	120	ns
延迟时间 Turn-Off delay time	$t_{d(off)}$		-	70	150	ns
下降时间 Turn-Off Fall time	$t_f$		-	55	120	ns
栅极电荷总量 Total Gate Charge	$Q_g$	$V_{DS}=480V,$ $I_D=4.5A$ $V_{GS}=10V$ (note 4, 5)	-	27	30	nC
栅-源电荷 Gate-Source charge	$Q_{gs}$		-	3.6	-	nC
栅-漏电荷 Gate-Drain charge	$Q_{gd}$		-	13.1	-	nC
漏-源二极管特性及最大额定值 Drain-Source Diode Characteristics and Maximum Ratings						
正向最大连续电流 Maximum Continuous Drain-Source Diode Forward Current	$I_S$		-	-	4.5	A
正向最大脉冲电流 Maximum Pulsed Drain-Source Diode Forward Current	$I_{SM}$		-	-	18	A
正向压降 Drain-Source Diode Forward Voltage	$V_{SD}$	$V_{GS}=0V, I_S=4.5A$	-	-	1.4	V
反向恢复时间 Reverse recovery time	$t_{rr}$	$V_{GS}=0V, I_S=4.5A$ $di_F/dt=100A/\mu s$ (note 4)	-	300	-	ns
反向恢复电荷 Reverse recovery charge	$Q_{rr}$		-	2.2	-	$\mu C$

**热特性 THERMAL CHARACTERISTIC**

项 目 Parameter	符 号 Symbol	最大 Max			单位 Unit
		JHW5N60V/R	JHW5N60S/B/C	JHW5N60F	
结到管壳的热阻 Thermal Resistance, Junction to Case	$R_{th(j-c)}$	2.50	1.25	3.79	$^{\circ}C/W$
结到环境的热阻 Thermal Resistance, Junction to Ambient	$R_{th(j-A)}$	83	62.5	62.5	$^{\circ}C/W$

注释:

- 1: 脉冲宽度由最高结温限制
- 2:  $L=25mH, I_{AS}=4.5A, V_{DD}=50V, R_G=25\Omega$ , 起始结温  $T_J=25^{\circ}C$
- 3:  $I_{SD} \leq 4.5A, di/dt \leq 200A/\mu s, V_{DD} \leq BV_{DSS}$ , 起始结温  $T_J=25^{\circ}C$
- 4: 脉冲测试: 脉冲宽度  $\leq 300\mu s$ , 占空比  $\leq 2\%$
- 5: 基本与工作温度无关

Notes:

- 1: Pulse width limited by maximum junction temperature
- 2:  $L=25mH, I_{AS}=4.5A, V_{DD}=50V, R_G=25\Omega$ , Starting  $T_J=25^{\circ}C$
- 3:  $I_{SD} \leq 4.5A, di/dt \leq 200A/\mu s, V_{DD} \leq BV_{DSS}$ , Starting  $T_J=25^{\circ}C$
- 4: Pulse Test: Pulse Width  $\leq 300\mu s$ , Duty Cycle  $\leq 2\%$
- 5: Essentially independent of operating temperature

特征曲线 ELECTRICAL CHARACTERISTICS (curves)

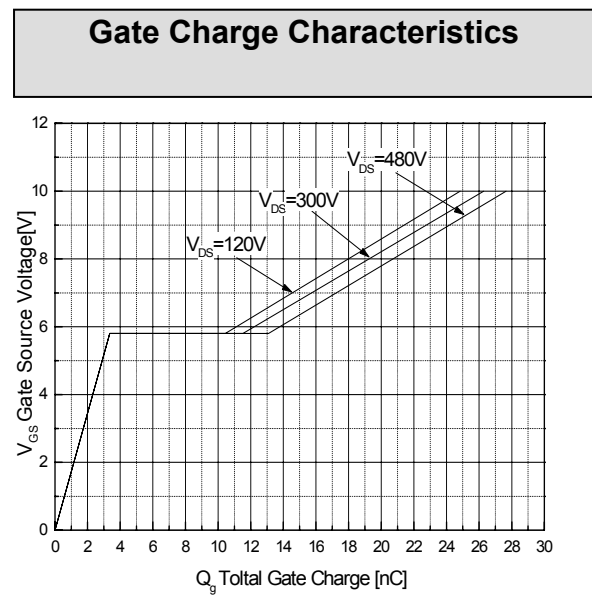
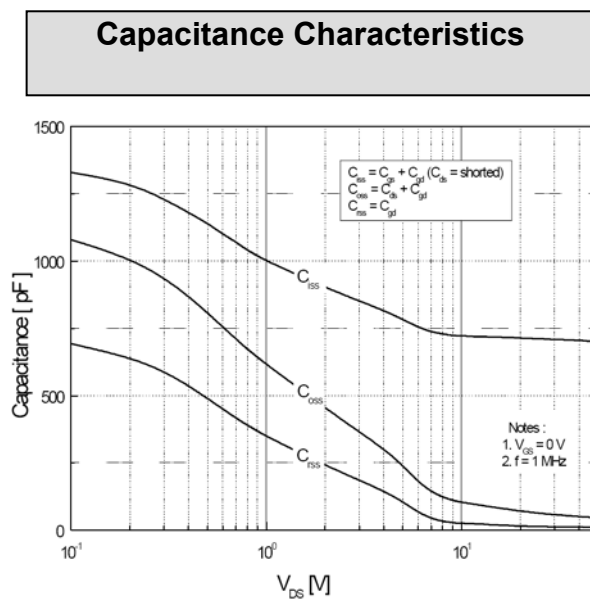
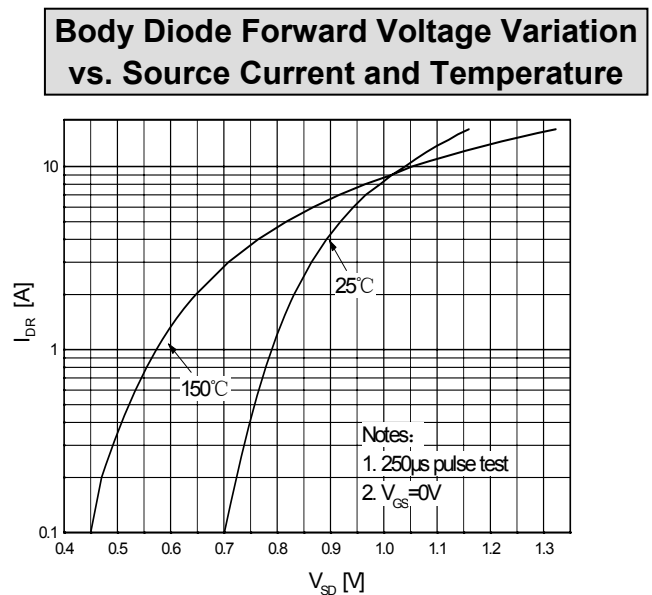
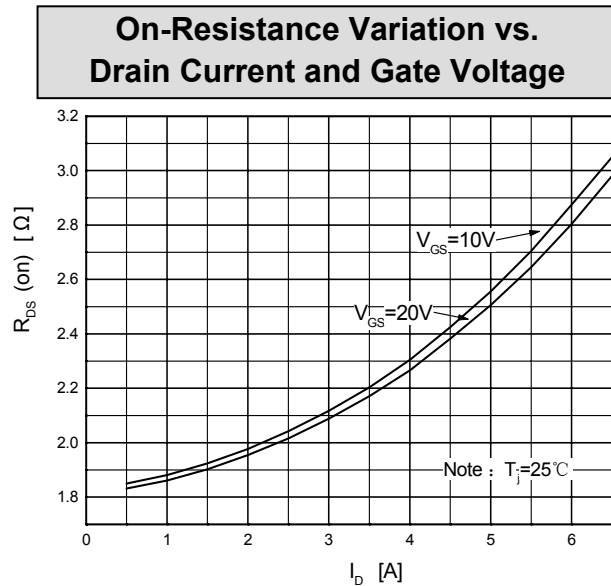
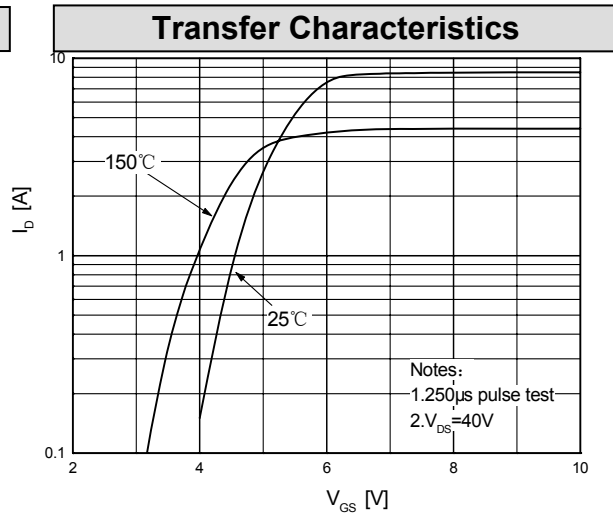
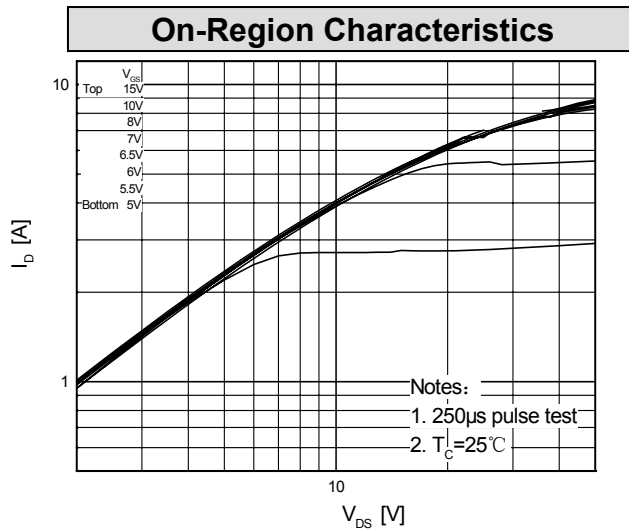

**特征曲线 ELECTRICAL CHARACTERISTICS (curves)**

**Breakdown Voltage Variation vs. Temperature**

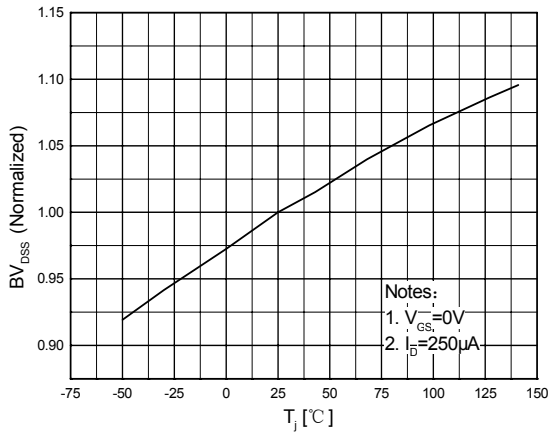

**On-Resistance Variation vs. Temperature**

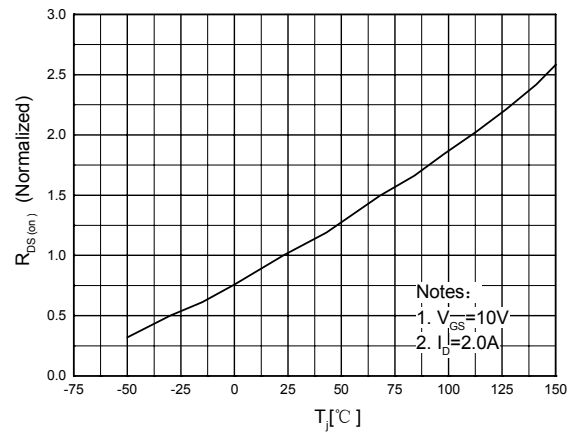

**Maximum Safe Operating Area For JHW5N60V/R/S/B/C**

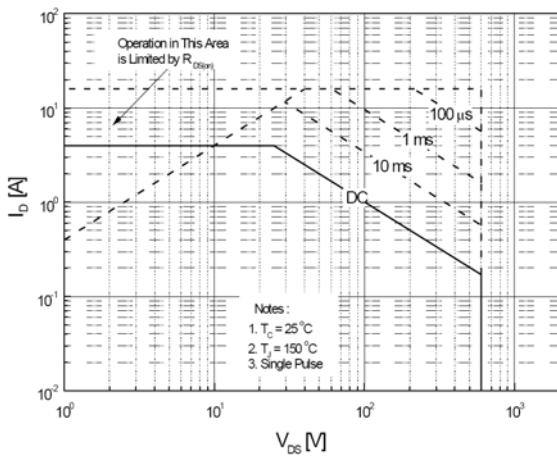

**Maximum Safe Operating Area For JHW5N60F**

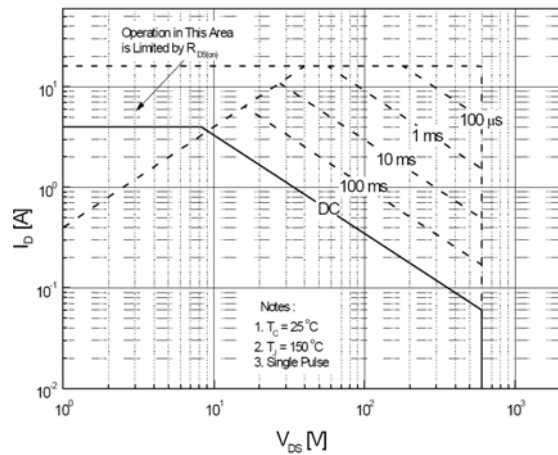

**Maximum Drain Current vs. Case Temperature**

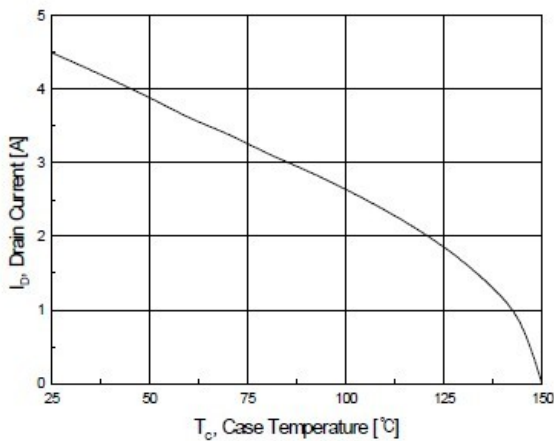

特征曲线 ELECTRICAL CHARACTERISTICS (curves)

**Transient Thermal Response Curve  
For JHW5N60V/R**

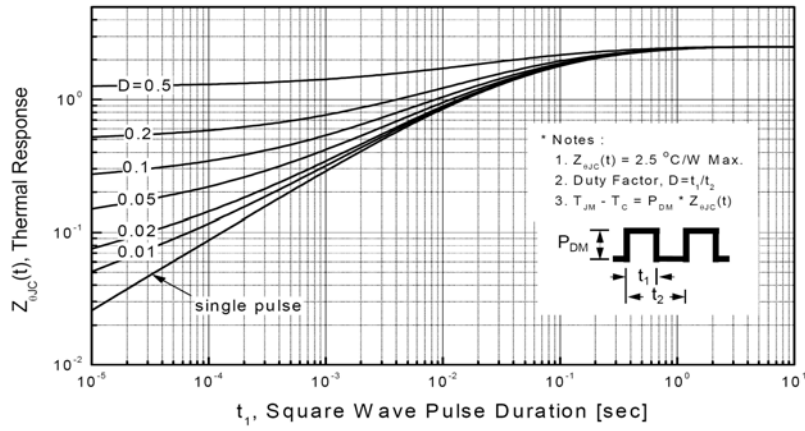

**Transient Thermal Response Curve  
For JHW5N60S/B/C**

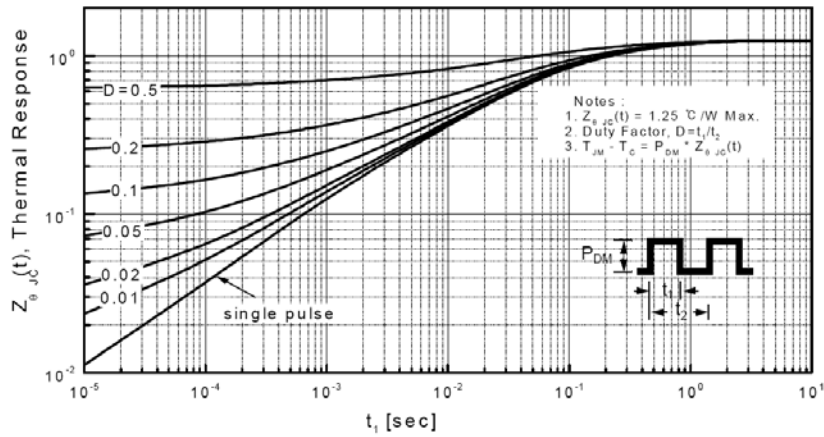

**Transient Thermal Response Curve  
For JHW5N60F**

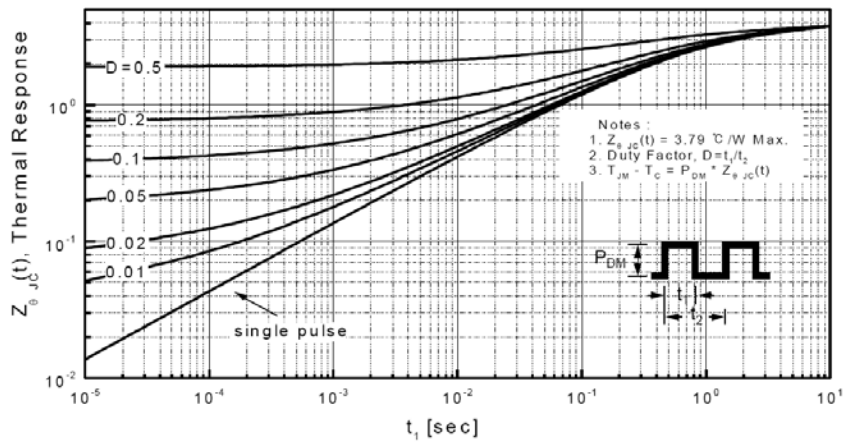

外形尺寸 PACKAGE MECHANICAL DATA

**IPAK**

单位 Unit: mm

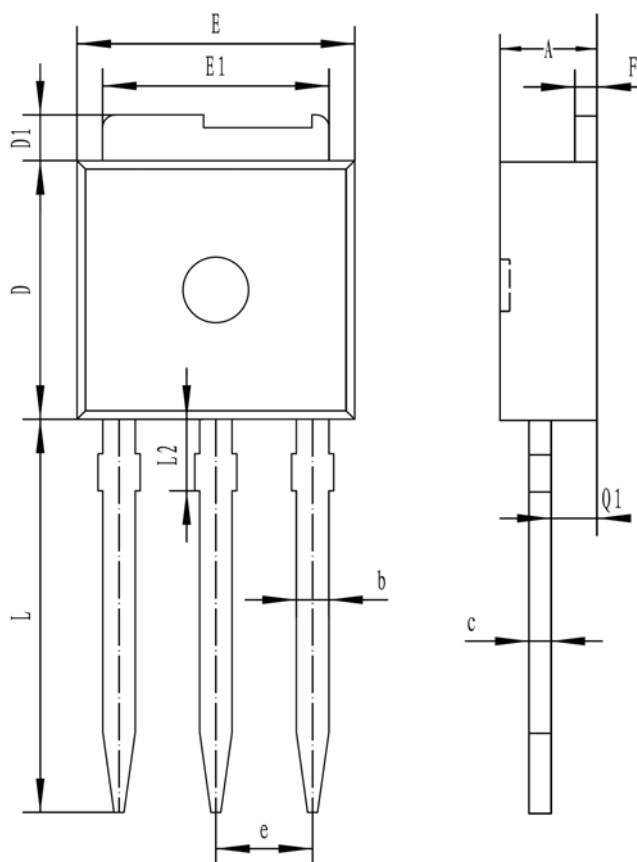

符号 symbol	MIN	MAX
A	2.19	2.38
b	0.64	0.89
c	0.46	0.58
D	5.97	6.22
D1	0.89	1.27
E	6.35	6.73
E1	5.21	5.46
e	2.28TYP	
F	0.46	0.58
L	8.89	9.65
L2	2.25	2.35
Q1	1.02	1.14



外形尺寸 PACKAGE MECHANICAL DATA

**DPAK**

单位 Unit: mm

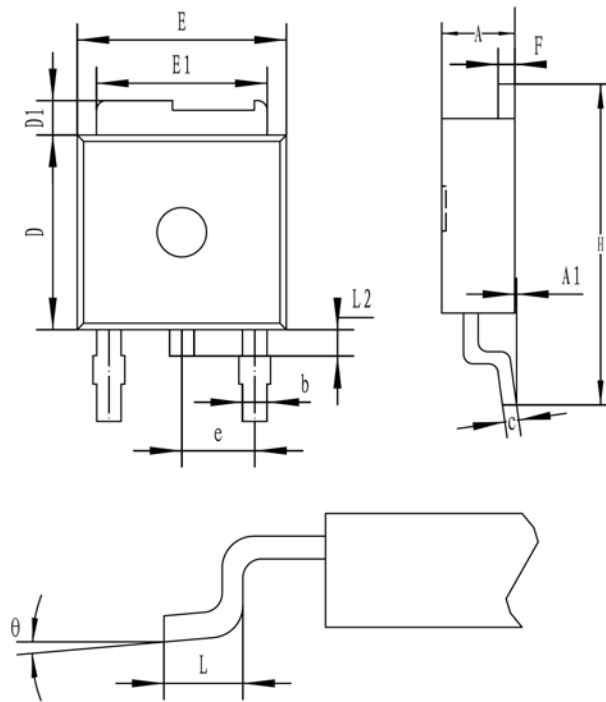

符号 symbol	MIN	MAX
A	2.19	2.38
A1		0.13
b	0.64	0.89
c	0.46	0.61
D	5.97	6.22
D1	0.89	1.27
E	6.35	6.73
E1	5.21	5.46
e	2.28TYP	
F	0.46	0.61
H	9.65	10.41
L	1.40	1.78
L2	0.64	1.01
$\theta$	0°	8°

外形尺寸 PACKAGE MECHANICAL DATA

**TO-262**

单位 Unit: mm

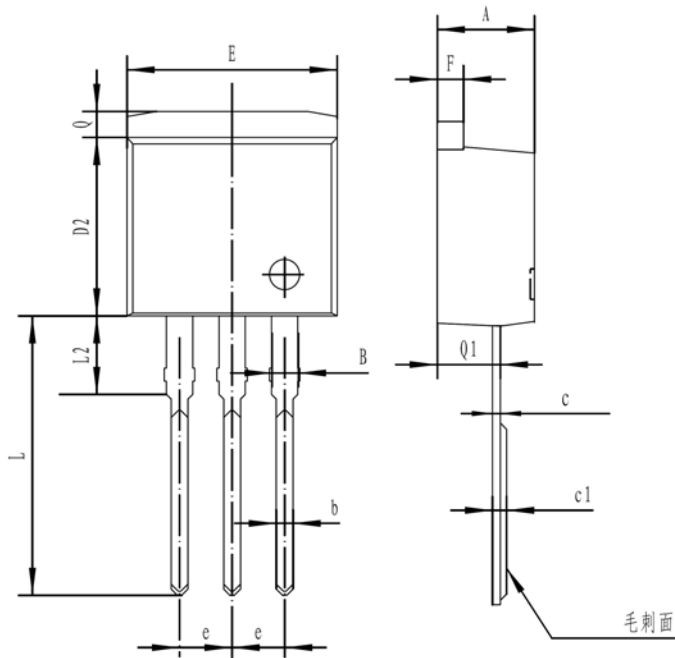

符号 symbol	MIN	MAX
A	4.40	4.90
B	1.10	1.40
b	0.70	0.95
c	0.30	0.60
c1	0.33	0.63
D2	8.20	9.20
E	9.60	10.50
e	2.39	2.69
F	1.20	1.35
L	13.11	14.61
L2	3.55	4.05
Q	1.10	1.40
Q1	2.65	2.85

外形尺寸 PACKAGE MECHANICAL DATA

**TO-263**

单位 Unit: mm

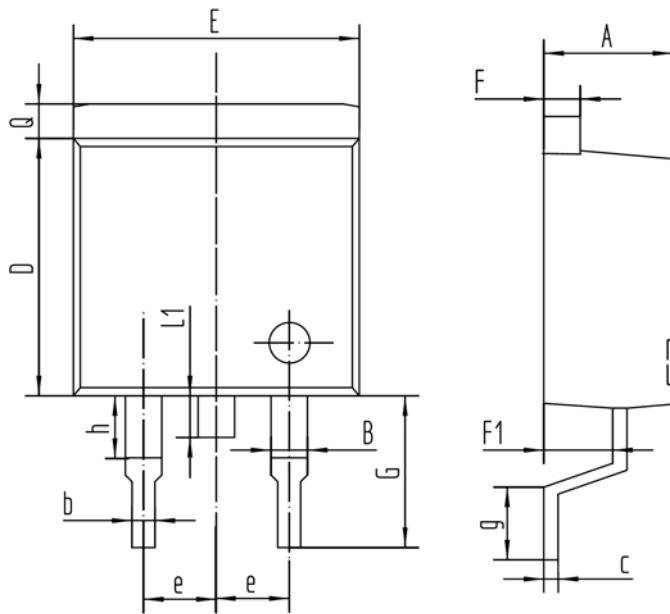

符号 symbol	MIN	MAX
A	4.50	4.90
B	1.20	1.40
D	8.40	8.80
E	9.50	10.50
F	1.20	1.40
F1	2.50	2.90
G	4.50	5.50
L1	1.30	1.60
Q	1.20	1.50
b	0.75	0.95
c	0.35	0.50
e	2.49	2.59
g	1.90	2.80
h	2.30	3.30

外形尺寸 PACKAGE MECHANICAL DATA

**TO-220C**

单位 Unit: mm

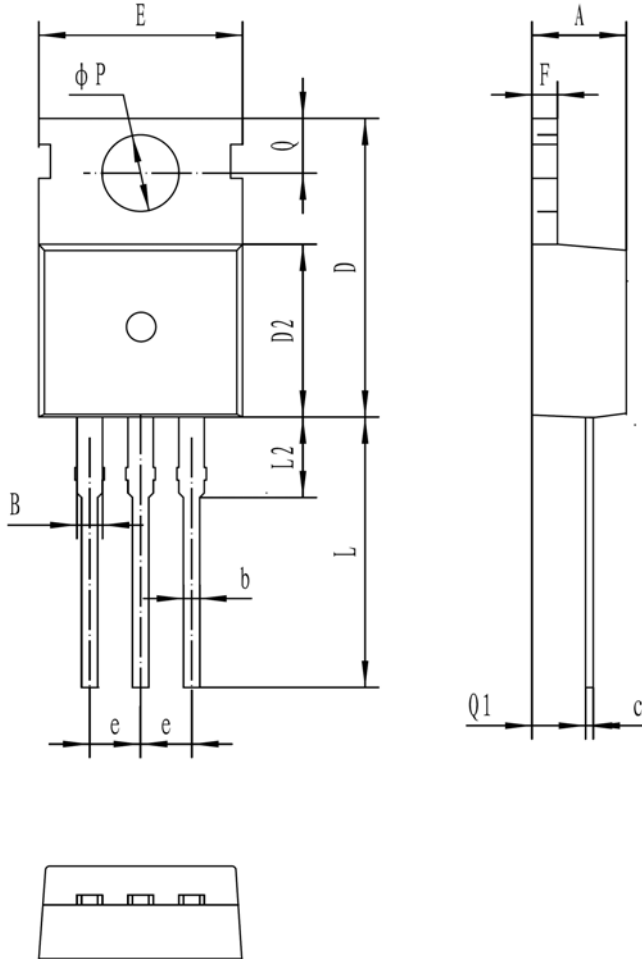

符号 symbol	MIN	MAX
A	4.30	4.70
B	1.10	1.40
b	0.70	0.95
c	0.40	0.65
D	15.20	16.20
D2	9.00	9.40
E	9.70	10.10
e	2.39	2.69
F	1.25	1.40
L	12.60	13.60
L2	2.80	3.20
Q	2.60	3.00
Q1	2.20	2.60
P	3.50	3.80

外形尺寸 PACKAGE MECHANICAL DATA

**TO-220MF**

单位 Unit: mm

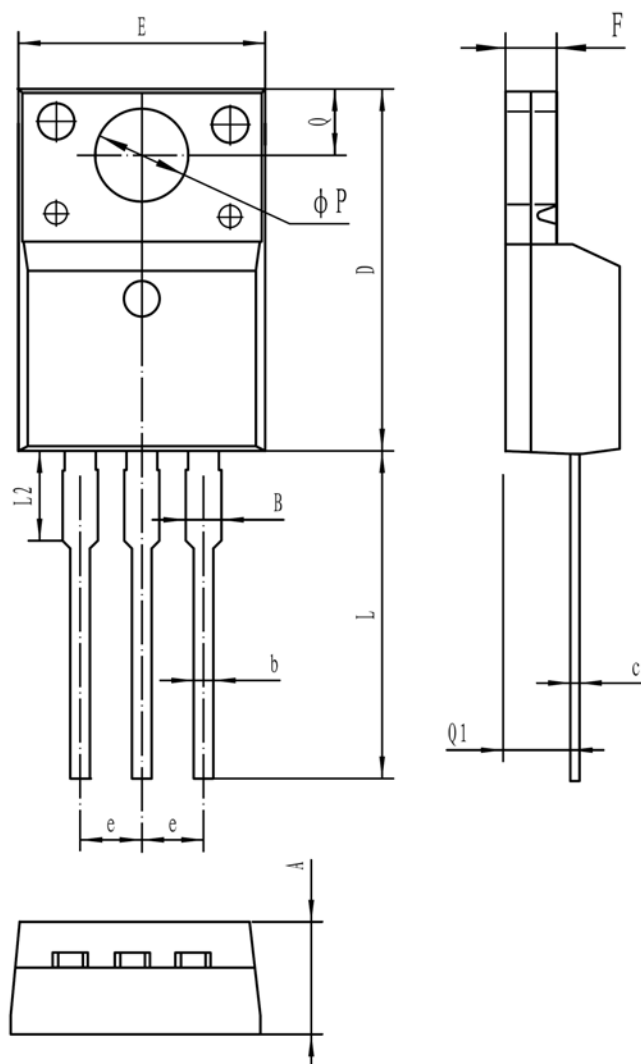

符号 Symbol	MIN	MAX
A	4.5	4.9
B	-	1.47
b	0.7	0.9
c	0.45	0.6
D	15.67	16.07
E	9.96	10.36
e	2.54TYPE	
F	2.34	2.74
L	12.58	13.38
L2	3.13	3.33
ΦP	3.08	3.28
Q	3.2	3.4
Q1	2.56	2.96