



JM38510/13501/13502

ULTRA-LOW OFFSET VOLTAGE OPERATIONAL AMPLIFIERS

Precision Monolithics Inc

FEATURES

- Low V_{OS} $25\mu V$
- Low V_{OS} Drift $0.6\mu V/^\circ C$
- Low Noise $0.6\mu V_{p-p}$
- Wide Supply Voltage Range $\pm 4.5V$ to $\pm 20V$

ORDERING INFORMATION

JAN SLASH SHEET	PMI DEVICE
JM38510/13501BGC	OP07AJ1/38510
JM38510/13501BGA	OP07AJ5/38510
JM38510/13501SGA	OP07SAJ5/38510
JM38510/13501BPB	OP07AZ2/38510
JM38510/13501BPA	OP07AZ5/38510
JM38510/13501SPA	OP07SAZ5/38510
JM38510/13502BGC	OP07J1/38510
JM38510/13502BGA	OP07J5/38510
JM38510/13502SGA	OP07SJ5/38510
JM38510/13502BPB	OP07Z2/38510
JM38510/13502BPA	OP07Z5/38510
JM38510/13502SPA	OP07SZ5/38510

GENERAL DESCRIPTION

This data sheet covers the electrical requirements for a monolithic, low offset voltage, internally-compensated operational amplifier as specified in MIL-M-38510/135 for device type 01 and 02. Devices supplied to this data sheet are manufactured and tested at PMI's MIL-M-38510 certified facility and are listed in QPL-38510.

Complete device requirements will be found in MIL-M-38510 and MIL-M-38510/135 for Class B and Class S processed devices.

GENERIC CROSS-REFERENCE INFORMATION

This cross-reference information is presented for the convenience of the user. The generic-industry types listed may not

have identical operational performance characteristics across the military temperature range or reliability factors equivalent to the MIL-M-38510 device.

MILITARY DEVICE TYPE	GENERIC-INDUSTRY TYPE
01	OP07A
02	OP07

For an 833-processed device with improved electrical specifications, review the OP-07 data sheet.

PIN CONNECTIONS

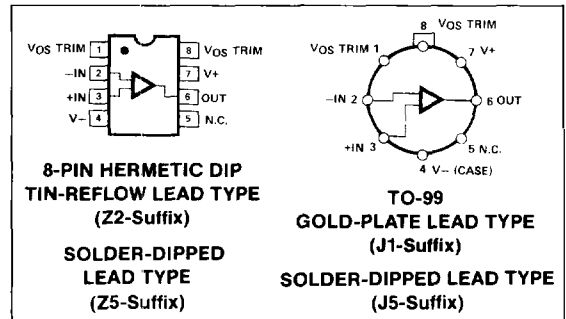

POWER AND THERMAL CHARACTERISTICS

Case Outline	Package	Maximum Allowable Power Dissipation	Maximum θ_{JC}	Maximum θ_{JA}
P	Dual-In-Line	208mW @ $T_A = 125^\circ C$	$50^\circ C/W$	$120^\circ C/W$
G	8-Lead CAN	167mW @ $T_A = 125^\circ C$	$40^\circ C/W$	$150^\circ C/W$

SIMPLIFIED SCHEMATIC

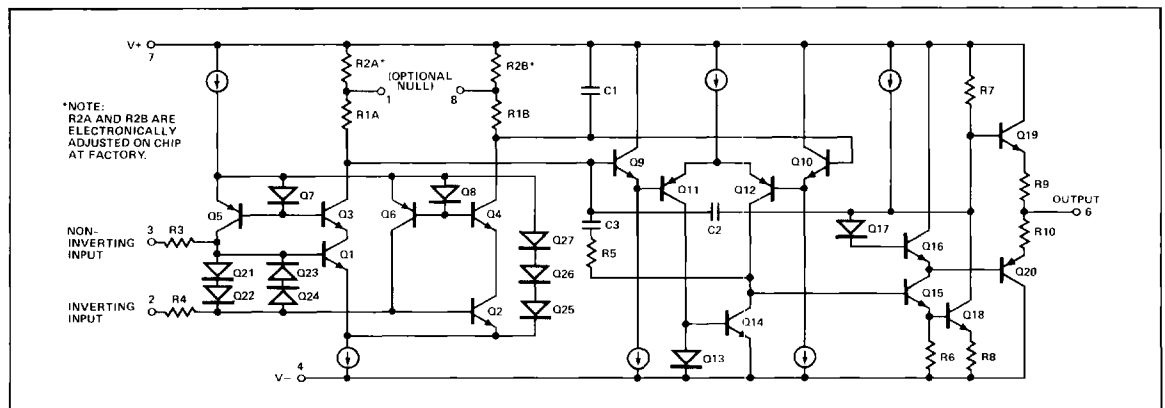

ABSOLUTE MAXIMUM RATINGS

Supply Voltage (V_{CC})	$\pm 22V$
Input Voltage Range (V_{IN})	$\pm V_{CC}$
Differential Input Voltage Range	$\pm 30V$
Output Short-Circuit Duration (Note 1)	
Lead Temperature (Soldering, 60 sec)	$+300^{\circ}C$
Storage Temperature Range	$-65^{\circ}C$ to $+150^{\circ}C$
Junction Temperature (T_J)	$+150^{\circ}C$
Maximum Power Dissipation (P_D) (Note 2)	500mW

RECOMMENDED OPERATING CONDITIONS

Supply Voltage Range	$\pm 4.5V$ to $\pm 20V$
Ambient Temperature Range	$-55^{\circ}C$ to $+125^{\circ}C$

NOTES:

- Output may be shorted to ground indefinitely at $V_S = \pm 15V$, $T_A = 25^{\circ}C$. Temperature and/or supply voltages must be limited to ensure dissipation rating is not exceeded.
- Maximum power dissipation versus ambient temperature.

ELECTRICAL CHARACTERISTICS at $\pm 4.5V \leq V_{CC} \leq \pm 20V$ and $-55^{\circ}C \leq T_A \leq 125^{\circ}C$, $R_S = 50\Omega$ unnullled, unless otherwise noted.

PARAMETER	SYMBOL	CONDITIONS	01 LIMITS		02 LIMITS		UNITS
			MIN	MAX	MIN	MAX	
Input Offset Voltage	V_{IO}	$T_A = 25^{\circ}C$ (Notes 1, 2)	-25 -60	25 60	-75 -200	75 200	μV
Input Offset Voltage Temperature Sensitivity	$\Delta V_{IO}/\Delta T$	(Note 1)	-0.6	0.6	-1.3	1.3	$\mu V/^{\circ}C$
Input Bias Current	$+I_{IB}$	$T_A = 25^{\circ}C$ (Note 1)	-2 -4	2 4	-3 -6	3 6	nA
	$-I_{IB}$	$T_A = 25^{\circ}C$ (Note 1)	-2 -4	2 4	-3 -6	3 6	
Input Offset Current	I_{IO}	$T_A = 25^{\circ}C$ (Note 1)	-2 -4	2 4	-2.8 -5.6	2.8 5.6	nA
	+PSRR	$+V_{CC} = 20V$ to $5V$, $-V_{CC} = -15V$ $T_A = 25^{\circ}C$	—	10	—	10	
	-PSRR	$+V_{CC} = 15V$, $-V_{CC} = -20V$ to $-5V$ $T_A = 25^{\circ}C$	—	10	—	10	
	+PSRR	$+V_{CC} = 20V$ to $5V$, $-V_{CC} = -15V$	—	20	—	20	
	-PSRR	$+V_{CC} = 15V$, $-V_{CC} = -20V$ to $-5V$	—	20	—	20	
	PSRR	$V_{CC} = \pm 4.5V$ to $\pm 20V$ $T_A = 25^{\circ}C$	—	10	—	10	
Power Supply Rejection Ratio	PSRR	$V_{CC} = \pm 4.5V$ to $\pm 20V$	—	20	—	20	$\mu V/V$

NOTES:

- Tested at $V_{CM} = 0$, $V_{CC} = \pm 15V$.
- Due to the inherent warm-up drift, testing shall occur no sooner than three (3) minutes after application of power.



OPERATIONAL AMPLIFIERS/BUFFERS

ELECTRICAL CHARACTERISTICS at $\pm 4.5V \leq V_{CC} \leq \pm 20V$ and $-55^\circ C \leq T_A \leq +125^\circ C$, $R_S = 50\Omega$ unnullled, unless otherwise noted. *Continued*

PARAMETER	SYMBOL	CONDITIONS	01 LIMITS		02 LIMITS		UNITS	
			MIN	MAX	MIN	MAX		
Common-Mode Rejection Ratio	CMRR	$V_{CM} = \pm 13V, T_A = +25^\circ C, V_{CC} = \pm 15V$	110	-	110	-	dB	
		$V_{CM} = \pm 13V, V_{CC} = \pm 15V$	106	-	106	-		
Adjustment for Input Offset	$V_{IO} \text{ Adj (+)}$	$T_A = +25^\circ C$ (Note 1)	0.5	-	0.5	-	mV	
	$V_{IO} \text{ Adj (-)}$	$T_A = +25^\circ C$ (Note 1)	-	0.5	-	0.5		
Output Short-Circuit Current	$I_{OS(+)}$	$t \leq 25ms$ (Notes 1, 3)	$T_A = +25^\circ C, +125^\circ C$	-65	-	-65	-	mA
			$T_A = -55^\circ C$	-70	-	-70	-	
	$I_{OS(-)}$	$t \leq 25ms$ (Notes 1, 3)	$T_A = +25^\circ C, +125^\circ C$	-	65	-	65	
			$T_A = -55^\circ C$	-	70	-	70	
Supply Current	I_{CC}	$T_A = +25^\circ C$	-	4	-	4	mA	
		(Note 1)	-	5	-	5		
Output Voltage Swing (Minimum)	V_{OP}	$R_L = 1k\Omega$ (Note 1)	-10	10	-10	10	V	
		$R_L = 2k\Omega$ (Note 1)	-12	12	-12	12		
Open-Loop Voltage Gain (Single-Ended)	A_{VS}	$T_A = +25^\circ C$	300	-	200	-	V/mV	
		(Notes 1, 2)	200	-	150	-		
Slew Rate	$SR(+), SR(-)$	$V_{IN} = 10V, T_A = +25^\circ C$, (Note 1)	0.08	-	0.08	-	V/ μs	
Input Noise Voltage Density	e_n	$f_O = 10Hz$	-	18	-	18	nV/ \sqrt{Hz}	
		$f_O = 100Hz, T_A = +25^\circ C$ (Note 1)	-	14	-	14		
		$f_O = 1kHz$	-	12	-	12		
Low Frequency Input Noise Voltage	e_{np-p}	$f = 0.1Hz$ to $10Hz, T_A = 25^\circ C$, (Note 1)	-	0.6	-	0.6	μV_{p-p}	

NOTES:

1. Tested at $V_{CM} = 0, V_{CC} = \pm 15V$.
2. $V_{OUT} = 0$ to $+10V$ for $A_{VS(+)}$ and $V_{OUT} = 0$ to $-10V$ for $A_{VS(-)}$; $R_L = 2k\Omega$.
3. Continuous short-circuit limits are considerably less than the indicated test limits, since maximum power dissipation cannot be exceeded.