



JM20329

Hi-Speed USB to SATA Bridge

Datasheet

Rev. 1.0

CONFIDENTIAL





Revision History

Version	Date	Revision Description
0.8	2007/3/20	Initialization of this document for JM20329.
0.9	2007/4/16	<ol style="list-style-type: none">1. Modify pin out description2. Remove the description about Serial Flash and Fingerprint recognition.3. Modify the EEPROM configuration description
1.0	2007/5/3	<ol style="list-style-type: none">1. Add pin description in USB suspend mode.2. Remove the typing error of pin17 in SATA power pin

© Copyright JMicon Technology, 2007.

All Rights Reserved.

Printed in Taiwan 2007

JMicron and the JMicon Logo are trademarks of JMicon Technology Corporation in Taiwan and/or other countries. Other company, product and service names may be trademarks or service marks of others.

All information contained in this document is subject to change without notice. The products described in this document are NOT intended for use implantation or other life supports application where malfunction may result in injury or death to persons. The information contained in this document does not affect or change JMicon's product specification or warranties. Nothing in this document shall operate as an express or implied license or environments, and is presented as an illustration. The results obtained in other operating environments may vary.

THE INFORMATION CONTAINED IN THIS DOCUMENT IS PROVIDED ON AN "AS IS" BASIS. In no event will JMicon be liable for damages arising directly or indirectly from any use of the information contained in this document.

JMicron Technology Corporation
1F, No.13, Innovation Road I,
Science Based Industrial Park
Hsinchu, Taiwan, R.O.C

For more information on JMicon products, please visit the JMicon web site at <http://www.JMicon.com> or send email to sales@jmicon.com



Table of Contents

1. General Description	4
2. Features	4
3. Main Applications.....	5
4. Block Diagram	5
5. Package and Pin Assignments.....	6
5.1 Package Pin Out	6
5.2 Package Outline.....	7
6. Pin Descriptions.....	8
6.1 Pin Type Definition.....	8
6.2 Serial ATA Interface	8
6.3 USB Interface.....	8
6.4 Crystal Interface.....	9
6.5 Voltage Regulator	9
6.6 Digital Power Supply and System Control Interface.....	9
7. Electrical Characteristics	11
7.1 Absolute Maximum Rating.....	11
7.2 Recommended Power Supply Operation Conditions	11
7.3 Recommended External Clock Source Conditions.....	11
7.4 Power Supply DC Characteristics.....	11
8. External Serial EEPROM Configuration	12



1. General Description

The JM20329 is the single chip solution to bridge between USB host and SATA device. The highly integrated Hi-Speed USB and SATA Phys technology provides a cost-effective solution to apply USB to SATA device enclosure. The USB adhere to the Mass Storage Class Bulk-Only Transport Specification. The embedded command parser supports both ATA and ATAPI command set with LBA48 addressing capability.

This chip is designed by 0.18um CMOS technology with 48 LQFP package.

2. Features

- Compliance with GenIi/GenIm of Serial ATA II Electrical Specification 2.5
- Support SATA II Asynchronous Signal Recovery (Hot Plug) feature
- Compliance with USB 2.0 electrical specification
- Support USB High-Speed and Full-Speed Operation
- Compliance with USB Mass Storage Class, Bulk-Only Transport Specification
- Support ATA/ATAPI PACKET command set
- Support ATA/ATAPI LBA48 addressing mode
- Support 12MHz external crystal
- Support external NVRAM for Vender Specific VID/PID of USB Device Controller
- Embedded 3.3V to 1.8V voltage regulator
- Single power 3.3V power supply
- 0.18um CMOS technology
- 48 LQFP package
- 8 GPIO

3. Main Applications

- Hi-Speed USB to SATA Device

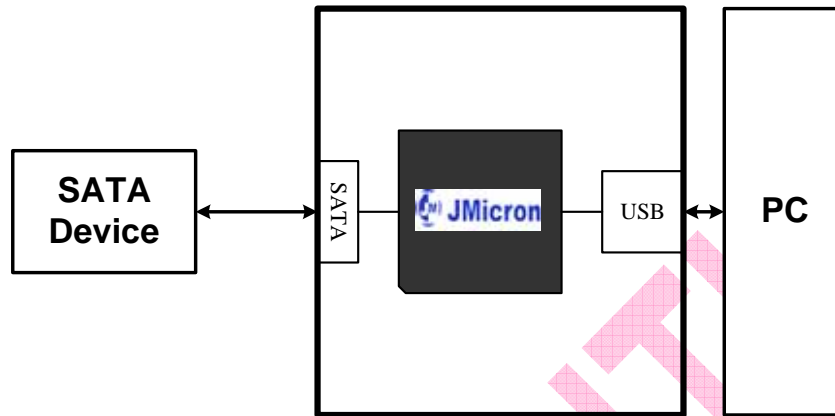

Figure 1 High-Speed USB to SATA Bridge

4. Block Diagram

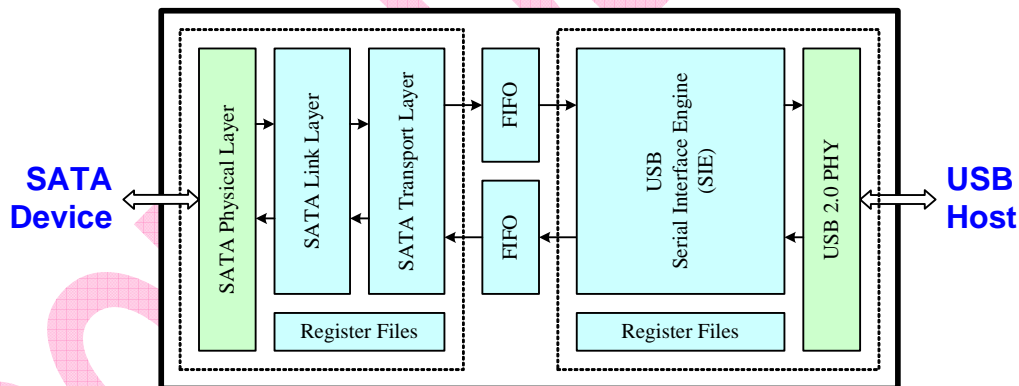

Figure 2 Block Diagram



5. Package and Pin Assignments

5.1 Package Pin Out

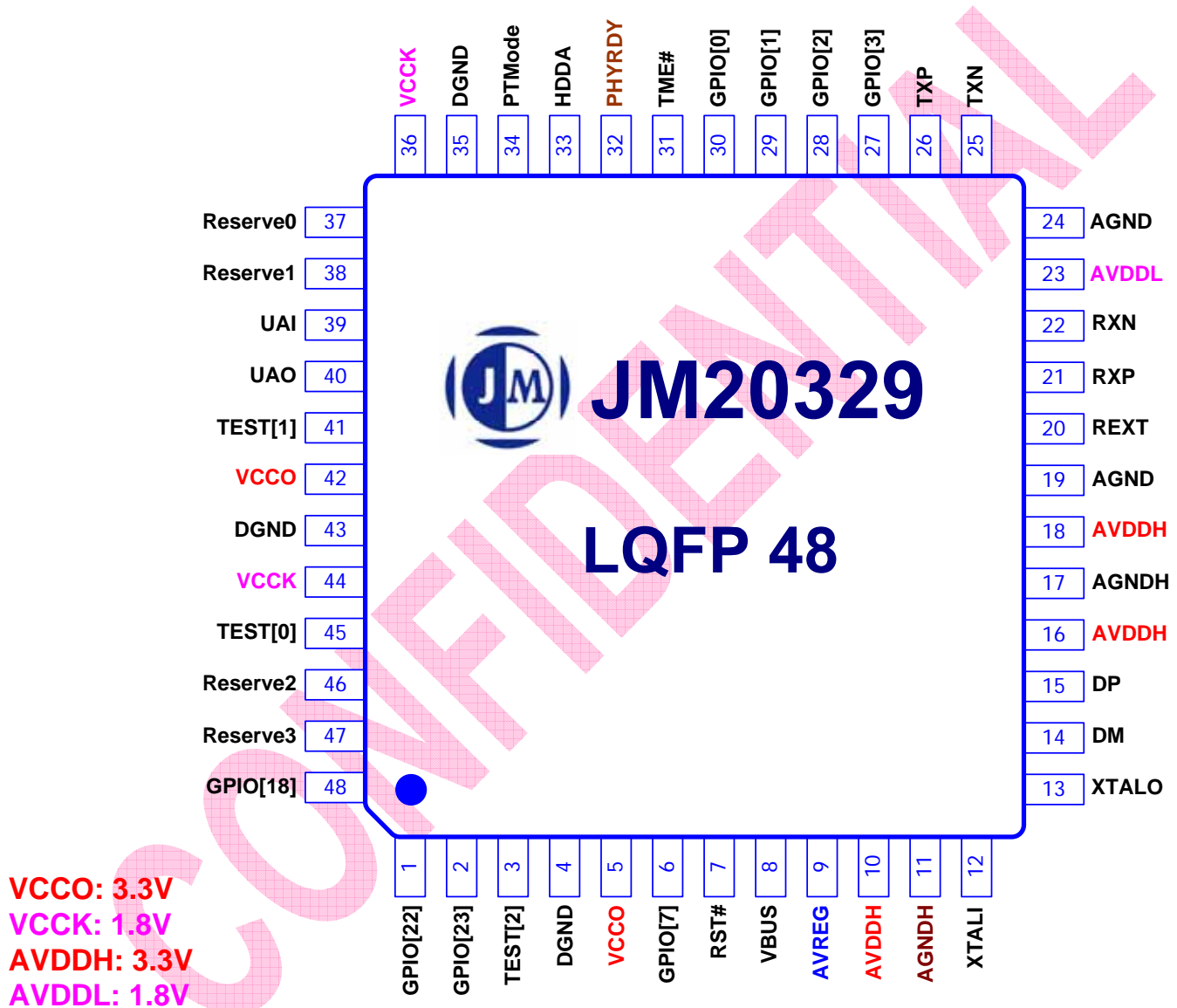
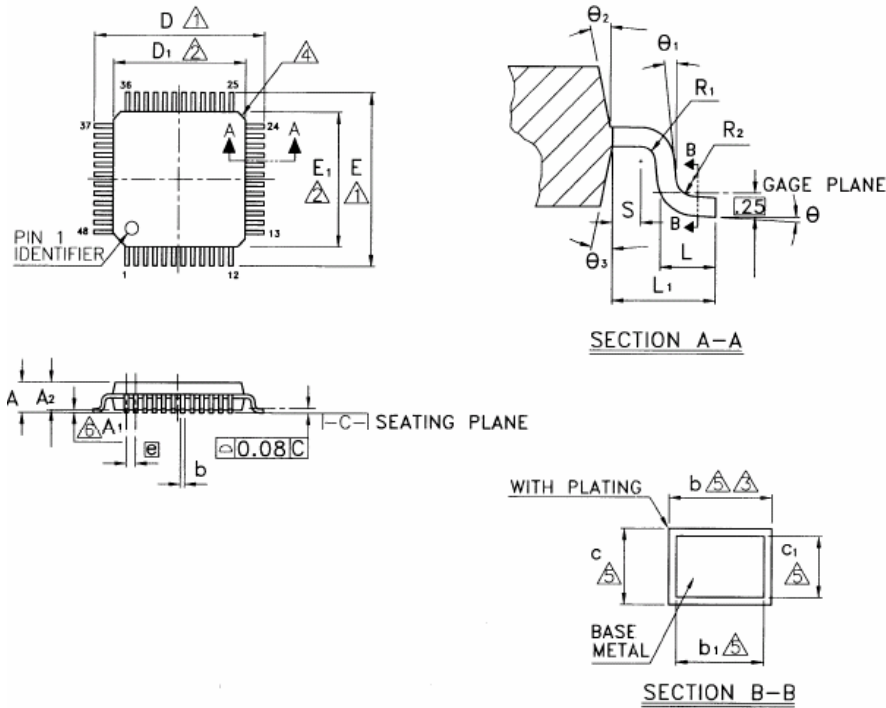

Figure 3 Package Pin Assignment



5.2 Package Outline

5.2.1 LQFP48 7X7 mm



Symbol	Dimension in mm			Dimension in inch		
	Min	Nom	Max	Min	Nom	Max
A	—	—	1.60	—	—	0.063
A ₁	0.05	—	0.15	0.002	—	0.006
A ₂	1.35	1.40	1.45	0.053	0.055	0.057
b	0.17	0.22	0.27	0.007	0.009	0.011
b ₁	0.17	0.20	0.23	0.007	0.008	0.009
c	0.09	—	0.20	0.004	—	0.008
c ₁	0.09	—	0.16	0.004	—	0.006
D	9.00 BSC			0.354 BSC		
D ₁	7.00 BSC			0.276 BSC		
E	9.00 BSC			0.354 BSC		
E ₁	7.00 BSC			0.276 BSC		
⓪	0.50 BSC			0.020 BSC		
L	0.45	0.60	0.75	0.018	0.024	0.030
L ₁	1.00 REF			0.039 REF		
R ₁	0.08	—	—	0.003	—	—
R ₂	0.08	—	0.20	0.003	—	0.008
S	0.20	—	—	0.008	—	—
θ	0°	3.5°	7°	0°	3.5°	7°
θ ₁	0°	—	—	0°	—	—
θ ₂	12°TYP			12°TYP		
θ ₃	12°TYP			12°TYP		



6. Pin Descriptions

6.1 Pin Type Definition

Pin Type	Definition
A	Analog
D	Digital
I	Input
O	Output
IO	Bi-directional
L	Internal weak pull-low (Typical 31 K Ω)
H	Internal weak pull-high (Typical 31 K Ω)

6.2 Serial ATA Interface

Signal Name	Pin No.	Type	Description
RXP	21	AI	Serial ATA RX+ signal. A 10nF CAP should be connected between this pin and SATA connector.
RXN	22	AI	Serial ATA RX- signal. A 10nF CAP should be connected between this pin and SATA connector.
TXP	26	AO	Serial ATA TX+ signal. A 10nF CAP should be connected between this pin and SATA connector.
TXN	25	AO	Serial ATA TX- signal. A 10nF CAP should be connected between this pin and SATA connector.
REXT	20	AI	External Reference Resistance. A 12K Ω ±1% external resistor should be connected to this pin.
AVDDL	23	AI	SATA Analog 1.8V Power Supply. This power could be sourced from internal 1.8V voltage regulator through AVREG pin.
AGND	24,19	AI	SATA Analog Ground.
AVDDH	18	AI	SATA Analog 3.3V Power Supply.

6.3 USB Interface

Signal Name	Pin No.	Type	Description
DM	14	AIO	USB Bus D- Signal.
DP	15	AIO	USB Bus D+ Signal.
VBUS	8	DIL	USB Cable Power Detector. The 4.7K Ω and 10K Ω resistances should be connected to divide the 5V cable power into 3.3V.
AVDDH	16	AI	USB Analog 3.3V Power Supply.
AGNDH	17	AI	USB Analog Ground.



6.4 Crystal Interface

Signal Name	Pin No.	Type	Description
XTALI	12	AI	Crystal Input/Oscillator Input. It is connected to a 12MHz crystal or crystal oscillator.
XTALO	13	AO	Crystal Output. It is connected to a crystal. While crystal oscillator is applied, this pin should be reserved as No Connection (NC).

6.5 Voltage Regulator

Signal Name	Pin No.	Type	Description
AVREG	9	AO	Voltage Regulator 1.8V Output.
AVDDH	10	AI	Voltage Regulator 3.3V Power Supply.
AGNDH	11	AI	Voltage Regulator Ground.

6.6 Digital Power Supply and System Control Interface

Signal Name	Pin No.	Type	Description
VCCO	5,42	DI	Digital 3.3V Power Supply.
VCKK	36,44	DI	Digital 1.8V Core Power.
DGND	4,35,43	DI	Digital Ground.
RST#	7	DIH	System Global Reset Input. Active-low to reset the entire chip. An external 10msec RC should be connected to this pin.
TME#	31	DIH	MP Test Mode Enable. This pin is reserved for IC mass production testing. Keep this pin to logic "1" in normal operation.
HDDA	33	DO	SATA Device Active. 0 : Device active. 1 : IDLE. Output to "0" in USB Suspend mode. (F)
TEST[2:0]	3,41,45	DIL DIL DIL	MP TEST Mode Selection. For IC mass production testing. We strongly recommend customer to make TEST[2:0] = 000. Input in USB Suspend mode
GPIO[0]	30	DIOH	ATA/ATAPI Power Down Mode Enable/EEPROM 9346 Data Output (DO) GPIO0 (1) At Power on MCU will detect this pin. 0: Enable MCU issue spin down command to HDD in suspend mode. 1: Disable MCU issue spin down command to HDD in suspend mode. (2) After power on status detecting, this pin becomes Data Output of serial EEPROM 9346. (3) While EEPROM detection is complete, this pin is default set to input, and could act as GPIO pin by SCSI-2 vender command (button input). Input in USB Suspend mode(F)



Signal Name	Pin No.	Type	Description
GPIO[1]	29	DIOH	EEPROM 9346 Data Input (DI) /GPIO1 (1) After power on status detecting, this pin becomes Data Input of serial EEPROM 9346. (2) While EEPROM detection is complete, this pin is default set to input, and could act as GPIO pin by SCSI-2 vender command (button input). Input in USB Suspend mode(F)
GPIO[2]	28	DIOH	USB Attach Sequence/EEPROM 9346 Serial Clock (SK)/GPIO2 (1) The internal controller will detect the pin status after power on. The functionality of power on initial state determines the USB attach sequence of JM20329 0: Attached USB first. 1: Check SATA device first. (2) This pin is Serial Clock of serial EEPROM 9346. (3) While EEPROM detection is complete, this pin is default set to input, and could act as GPIO pin by SCSI-2 vender command (button input). Input in USB Suspend mode (F)
GPIO[3]	27	DIOH	EEPROM 9346 Chip Select (CS) /GPIO3 (1) This pin functions as Chip Select of EEPROM 9346 in EEPROM detection. (2) While EEPROM detection is complete, this pin is default set to input, and could act as GPIO pin by SCSI-2 vender command. Note that it only supports 9346 with 64x16-bit mode. Input in USB Suspend mode (F)
PTMODE	34	DIH	Protocol mode 1: Enable USB to SATA function. 0: Disable USB and SATA function. Input in USB Suspend mode (F)
GPIO[7]	6	DIO	GPIO 7: USB Bus State. This pin will go high while the USB Vbus is applied. It will go low only in (1) Vbus is detached. (2) Vbus is attached and USB is configured and enter suspend state. (F)
GPIO[18]	48	DIO	Can be configured by SCSI-2 vender command. Output to "0" in USB Suspend mode(F)
GPIO[22]	1	DIO	Can be configured by SCSI-2 vender command. Output to "0" in USB Suspend mode(F)
GPIO[23]	2	DIO	Can be configured by SCSI-2 vender command Output to "0" in USB Suspend mode. (F)
Reserved[3:0]	47,46,38 ,37	DIO DIO DIOH DIOH	Reserved Pins. They are for internal used only. We strongly recommend customer to make Reserved[3:0] = 0011. Input in USB Suspend mode (F)
UAI	39	DIH	8051 UART interface. Input in USB Suspend mode
UAO	40	DO	8051 UART interface. Output to "1" in USB Suspend mode.
PHYRDY	32	DO	SATA PHY is ready. 0: SATA interface not established. 1: SATA interface established. Output to "0" in USB Suspend mode.



7. Electrical Characteristics

7.1 Absolute Maximum Rating

Parameter	Symbol	Condition	Min	Max	Unit
Analog power supply	AVDDH		-0.5	6	V
Digital I/O power supply	DVDD		-0.5	6	V
Digital I/O input voltage	$V_{I(D)}$		-0.4	DVDD+0.4	V
Storage temperature	$T_{STORAGE}$		-55	140	°C

7.2 Recommended Power Supply Operation Conditions

Parameter	Symbol	Condition	Min	Typical	Max	Unit
Operation digital power supply	DVDD		3.0	3.3	3.6	V
Operation analog power supply	AVDDH		3.0	3.3	3.6	V
Ambient operation temperature	T_A		-10		70	°C
Junction temperature	T_J		0		125	°C

7.3 Recommended External Clock Source Conditions

Parameter	Symbol	Condition	Min	Typical	Max	Unit
External reference clock				12		MHz
Clock Duty Cycle			45	50	55	%

7.4 Power Supply DC Characteristics

Parameter	Symbol	Condition	Min	Typical	Max	Unit
Digital I/O power supply	I_{DVDD}	3.3v		1		mA
Internal digital Power Supply	I_{DDH_VR}	1.8v		47		mA
USB Analog Power Supply	I_{AVDDH_USB}	3.3v		27		mA
SATA Analog Power Supply	I_{AVDDH_SATA}	3.3v		36		mA
SATA Analog Power Supply	I_{AVDDL_SATA}	1.8v		62		mA



8. External Serial EEPROM Configuration

The external EEPROM only support 9346 at 64x16 mode. The vender could store the Vender specific USB Device Descriptor, Manufacture String (Index 0x0A), and Product String (Index 0x0B) according to the below table.

Support 3 strings:

1. Manufacture or HDD one of them

The Manufacture-String maximum size is 30 characters.

The HDD-String maximum size is 24 characters.

2. Product string

The Product-string maximum size is 30 characters.

3. Serial number

The Serial number-string maximum size is 30 characters.

CONFIDENTIAL