



JMF601

SATA II to Flash Controller

Overview

JMF601 is a single chip with Serial ATA Gen II and USB 2.0 combo to NAND flash interface. It is an innovative design to provide high bandwidth for flash memory access.

JMF601 can support the maximum read and write speed to drive the limit of flash memory. It supports up to 64 NAND Flash chips. JMF601 is available in 130 pin TFBGA (9mm x 9 mm) package.

JMF601 supports a variety of popular NAND flash memory, including Toshiba, Samsung, Hynix/ST and Intel/Micron Flash. With the embedded hardware error correction engines and the robust bad block management technology, JMF601 is suitable for PC and industrial solid state drive applications. In addition, dynamic and whole drive static wear leveling are used in JMF601 to provide the best extension of drive life time.

JMicron also provides reference designs in different drive form factors, mass production tool and firmware update tool to help customers go on mass product quickly.

Feature

Compliance

- Compliant with **Universal Serial Bus Specification Revision 2.0**
- Compliant with **USB Mass Storage Class specification version 1.0**
- Compliant with **Serial ATA International Organization : Serial ATA Revision 2.6**

USB 2.0

- USB Bulk mode transport protocol

SATA II

- Supports 3.0Gbps SATA II interface

FLASH

- Supports up to 64 CEs.
- 110/90 MB/s Sequential read/write rates
- Enhanced endurance by Dynamic/Static wear-leveling
- Supports BCH ECC to correct 8/15 bit errors in 512 bytes
- Support both 2K and 4K byte page size flash
- Supports dynamic power management
- Support SMART function
- Data integrity under power-cycling
- Supports USB/SATA firmware upgrade

SYSTEM

- Integrated 1-port USB2.0, 1-port SATA II and 4-channel Flash controller
- LED indicator for USB2.0 and SATA read/write access
- LED indicator for USB2.0 and SATA PHY link up
- Provides 12 GPIO pins for customer
- Provides UART and JTAG for S/W debugging
- Available in 130-pin TFBGA (9 mm * 9 mm) package
- Built-in power-up self-test (BIST)
- Manual and automatic self-diagnostics

Functional Block Diagram

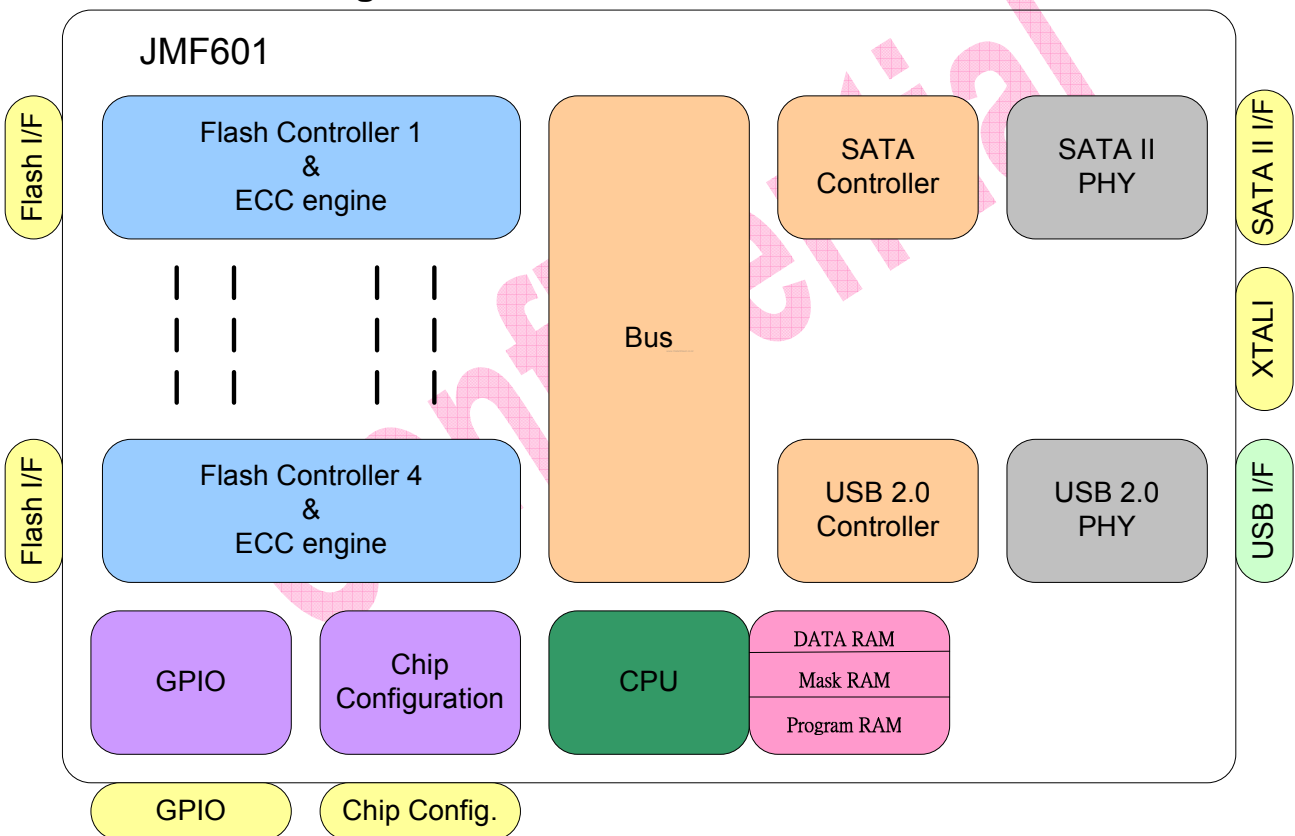

Functional Block Diagram of JMF601



Total capacity

density/per flash	Support CE pins/per flash	maximum flash number	Total capacity
128M x 8 Bits (1Gb)	1 CE pin	64	8G Bytes
256M x 8 Bits (2Gb)	1 CE pin	64	16G Bytes
512M x 8 Bits (4Gb)	1 CE pin	64	32G Bytes
1G x 8 Bits (8Gb)	2 CE pins	32	32G Bytes
1G x 8 Bits (8Gb)	1 CE pin	64	64G Bytes
2G x 8 Bits (16Gb)	2 CE pins	32	64G Bytes
4G x 8 Bits (32Gb)	4 CE pins	16	64G Bytes

Product Information

Name	Description
JMF601	SATA II to Flash Controller

Document

1	JMF601 Data Sheet
2	JMF601 Design Specification
3	JMF601 Hardware Design Guide
4	JMF601 Hardware Schematic

Contact Information

Department	Email
Sales	sales@jmicron.com
Tech. Support	fae@jmicron.com