



JR0405 Series Sensitive gate SCRs

Rev.8.0

DESCRIPTION:

The JR0405 SCR series with the parallel resistor between Gate and Cathode are especially recommended for use on straight hair, igniter, anion generator, etc.

MAIN FEATURES

Symbol	Value	Unit
$I_{T(RMS)}$	4	A
I_{GT}	≤ 200	μA
V_{TM}	≤ 1.5	V

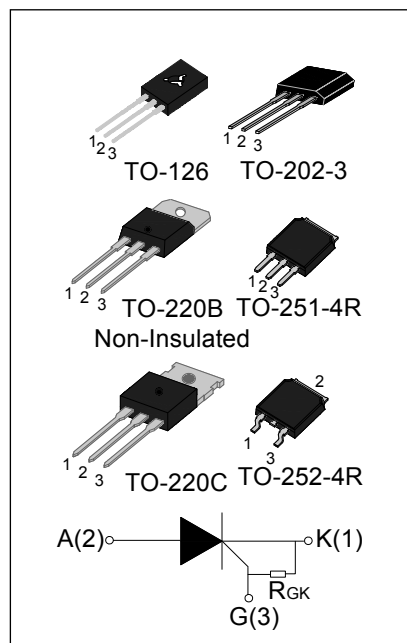

ABSOLUTE MAXIMUM RATINGS

Parameter	Symbol	Value	Unit	
Storage junction temperature range	T_{stg}	-40-150	$^{\circ}C$	
Operating junction temperature range	T_j	-40-125 ^①	$^{\circ}C$	
Repetitive peak off-state voltage	V_{DRM}	600	V	
Repetitive peak reverse voltage	V_{RRM}	600	V	
RMS on-state current	$I_{T(RMS)}$	TO-220B(Non-Ins) / TO-220C($T_C=95^{\circ}C$)	4	A
		TO-251-4R/ TO-252-4R/ TO-202-3 ($T_C=80^{\circ}C$)		
		TO-126 ($T_C=75^{\circ}C$)		
Non repetitive surge peak on-state current (tp=10ms)	I_{TSM}	30	A	
I^2t value for fusing (tp=10ms)	I^2t	4.5	A^2s	
Critical rate of rise of on-state current	dI/dt	50	$A/\mu s$	
Peak gate current (tp=20 μs , $T_j=110^{\circ}C$)	I_{GM}	1.2	A	
Peak gate power (tp=20 μs , $T_j=110^{\circ}C$)	P_{GM}	2	W	

Average gate power dissipation($T_j=110^\circ\text{C}$)	$P_{G(AV)}$	0.2	W
---	-------------	-----	---

NOTE 1: $T_j=125^\circ\text{C}$ with $R_{GK}=1\text{K}\Omega$; $T_j=110^\circ\text{C}$ without R_{GK} .

ELECTRICAL CHARACTERISTICS ($T_j=25^\circ\text{C}$ unless otherwise specified)

Symbol	Test Condition	Value			Unit
		MIN.	TYP.	MAX.	
I_{GT}	$V_D=12\text{V}$ $R_L=33\Omega$	-	50	200	μA
V_{GT}		-	0.6	0.8	V
V_{GD}	$V_D=V_{DRM}$ $T_j=110^\circ\text{C}$	0.2	-	-	V
I_L	$I_G=1.2 I_{GT}$	-	-	6	mA
I_H	$I_T=0.05\text{A}$	-	-	5	mA
dV/dt	$V_D=2/3V_{DRM}$ $T_j=110^\circ\text{C}$ $R_{GK}=1\text{K}\Omega$	10	-	-	V/ μs

STATIC CHARACTERISTICS

Symbol	Parameter		Value(MAX)	Unit
V_{TM}	$I_{TM}=8\text{A}$ $t_p=380\mu\text{s}$	$T_j=25^\circ\text{C}$	1.5	V
I_{DRM}	$V_D=V_{DRM}$ $V_R=V_{RRM}$	$T_j=25^\circ\text{C}$	5	μA
I_{RRM}		$T_j=110^\circ\text{C}$	200	μA

THERMAL RESISTANCES

Symbol	Parameter		Value	Unit
$R_{th(j-c)}$	junction to case	TO-220B(Non-Ins)/ TO-220C	2.8	$^\circ\text{C/W}$
		TO-251-4R/ TO-252-4R	6.5	
		TO-202-3/TO-126	7.2	

ORDERING INFORMATION

<p>J</p> <p>JieJie Microelectronics Co.,Ltd</p> <p>Sensitive gate SCRs</p>	<p>R</p> <p>$I_{T(RMS)}:4A$</p> <p>05: $I_{GT} \leq 200\mu A$</p>	<p>04</p>	<p>05</p>	<p>H</p> <p>S3:TO-202-3 K:TO-252-4R Q:TO-126 H:TO-251-4R B:TO-220B(Non-Ins)C:TO-220C</p>
---	--	------------------	------------------	---

PACKAGE MECHANICAL DATA

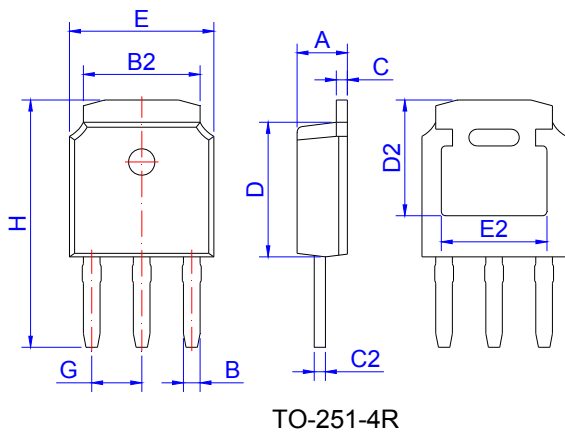

Ref.	Dimensions					
	Millimeters			Inches		
	Min.	Typ.	Max.	Min.	Typ.	Max.
A	2.10	2.30	2.50	0.083	0.091	0.098
B	0.66	0.76	0.86	0.026	0.030	0.034
B2	5.15	5.33	5.48	0.203	0.210	0.216
C	0.44	0.51	0.58	0.017	0.020	0.023
C2	0.44	0.51	0.58	0.017	0.020	0.023
D	5.90	6.10	6.30	0.232	0.240	0.248
D2	5.30 REF			0.209 REF		
E	6.40	6.60	6.80	0.252	0.260	0.268
E2	4.83 REF			0.190 REF		
G	2.19	2.29	2.39	0.086	0.090	0.094
H	10.60	11.20	11.80	0.417	0.441	0.465

PACKAGE MECHANICAL DATA

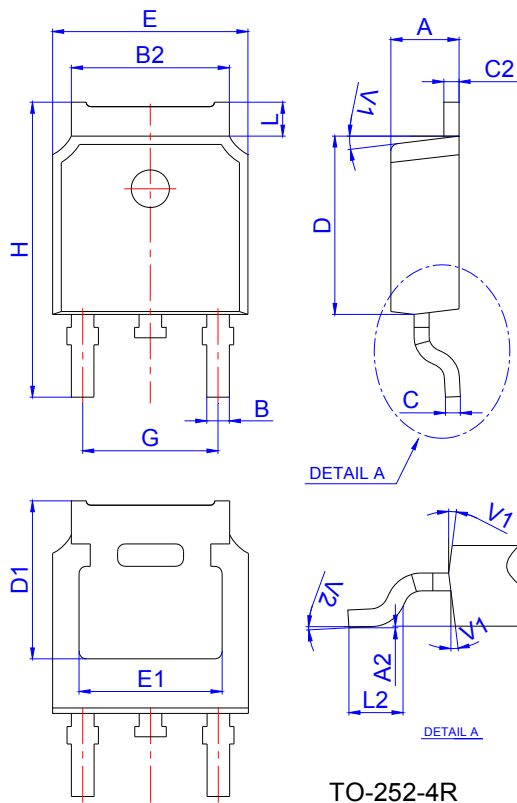

Ref.	Dimensions					
	Millimeters			Inches		
	Min.	Typ.	Max.	Min.	Typ.	Max.
A	2.10		2.50	0.083		0.098
A2	0		0.10	0		0.004
B	0.66		0.86	0.026		0.034
B2	5.18		5.48	0.202		0.216
C	0.40		0.60	0.016		0.024
C2	0.44		0.58	0.017		0.023
D	5.90		6.30	0.232		0.248
D1	5.30REF			0.209REF		
E	6.40		6.80	0.252		0.268
E1	4.63			0.182		
G	4.47		4.67	0.176		0.184
H	9.50		10.70	0.374		0.421
L	1.09		1.21	0.043		0.048
L2	1.35		1.65	0.053		0.065
V1		7°			7°	
V2	0°		6°	0°		6°

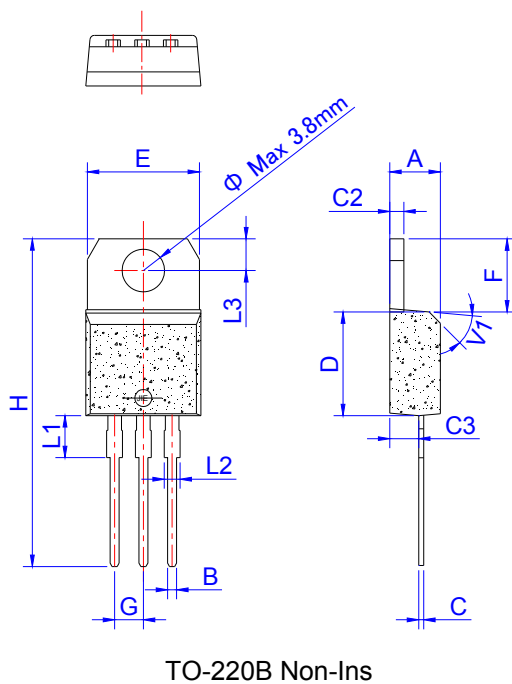

Ref.	Dimensions					
	Millimeters			Inches		
	Min.	Typ.	Max.	Min.	Typ.	Max.
A	4.40		4.60	0.173		0.181
B	0.61		0.88	0.024		0.035
C	0.46		0.70	0.018		0.028
C2	1.21		1.32	0.048		0.052
C3	2.40		2.72	0.094		0.107
D	8.60		9.70	0.339		0.382
E	9.60		10.4	0.378		0.409
F	6.20		6.60	0.244		0.260
G		2.54			0.1	
H	28.0		29.8	1.102		1.173
L1		3.75			0.148	
L2	1.14		1.70	0.045		0.067
L3	2.65		2.95	0.104		0.116
V1		45°			45°	

PACKAGE MECHANICAL DATA

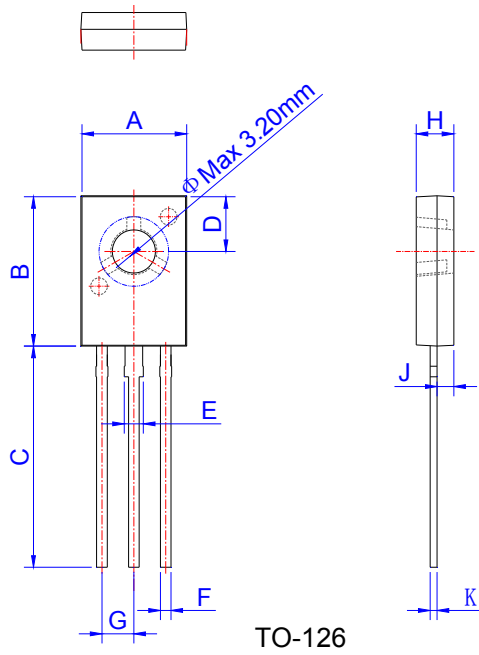

Ref.	Dimensions					
	Millimeters			Inches		
	Min.	Typ.	Max.	Min.	Typ.	Max.
A	7.40		7.80	0.291		0.307
B	10.6		11.2	0.417		0.441
C	15.3		16.3	0.602		0.642
D	3.90		4.10	0.154		0.161
E	1.17		1.47	0.046		0.058
F	0.66		0.86	0.026		0.034
G		2.29			0.090	
H	2.50		2.90	0.098		0.114
J	1.10		1.50	0.043		0.059
K	0.45		0.60	0.018		0.024

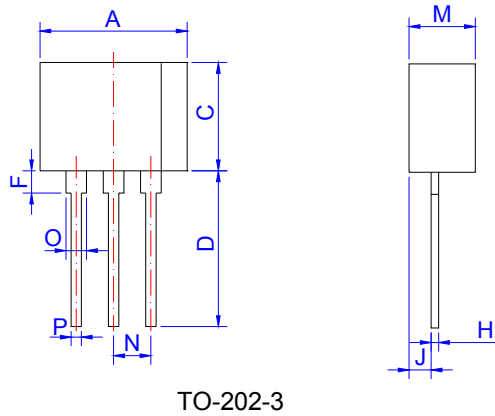

Ref.	Dimensions					
	Millimeters			Inches		
	Min.	Typ.	Max.	Min.	Typ.	Max.
A	9.30		9.90	0.366		0.390
C	7.0		7.6	0.276		0.299
D	10.5		11.5	0.413		0.453
F	1.50		2.50	0.059		0.098
H	0.45		0.55	0.018		0.022
J	1.50		1.90	0.059		0.075
M	4.40		4.70	0.173		0.185
N		2.54			0.100	
O	1.20		1.50	0.047		0.059
P	0.60		0.80	0.024		0.031

PACKAGE MECHANICAL DATA

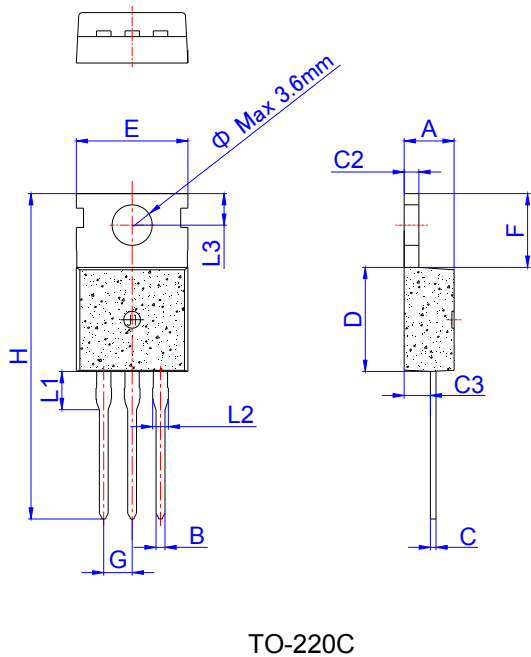

Ref.	Dimensions					
	Millimeters			Inches		
	Min.	Typ.	Max.	Min.	Typ.	Max.
A	4.40		4.60	0.173		0.181
B	0.70		0.90	0.028		0.035
C	0.45		0.60	0.018		0.024
C2	1.23		1.32	0.048		0.052
C3	2.20		2.60	0.087		0.102
D	8.90		9.90	0.350		0.390
E	9.90		10.3	0.390		0.406
F	6.30		6.90	0.248		0.272
G		2.54			0.1	
H	28.0		29.8	1.102		1.173
L1		3.39			0.133	
L2	1.14		1.70	0.045		0.067
L3	2.65		2.95	0.104		0.116
Φ		3.6			0.142	

FIG.1: Maximum power dissipation versus RMS on-state current

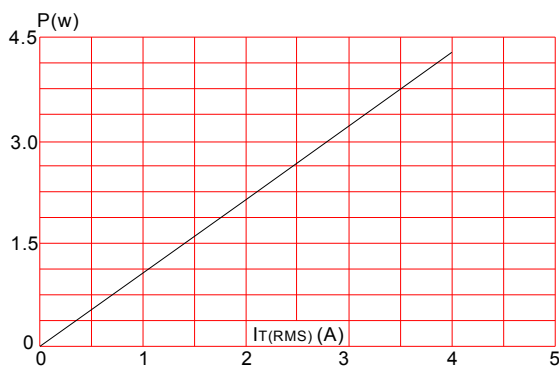

FIG.2: RMS on-state current versus case temperature

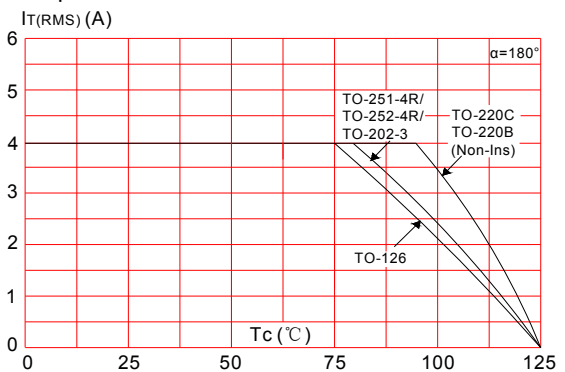

FIG.3: Surge peak on-state current versus number of cycles

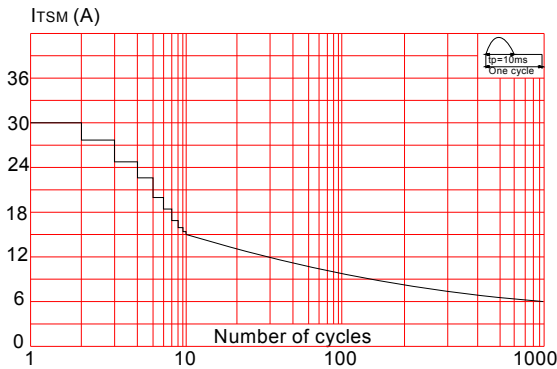

FIG.5: Non-repetitive surge peak on-state current for a sinusoidal pulse with width $t_p < 10\text{ms}$, and corresponding value of I^2t ($di/dt < 50\text{A}/\mu\text{s}$)

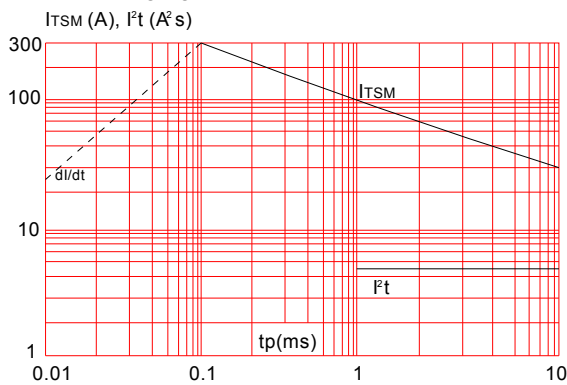

FIG.4: On-state characteristics (maximum values)

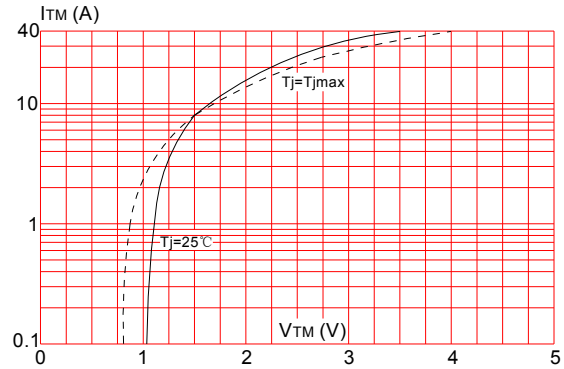
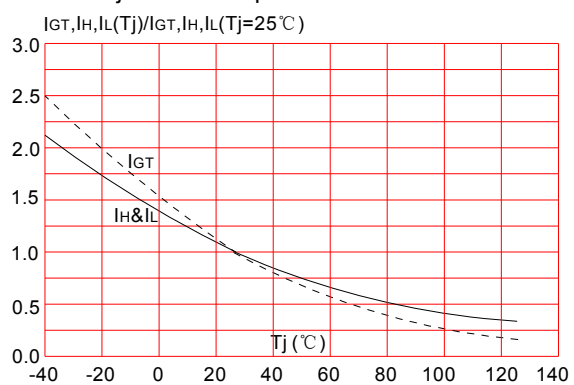



FIG.6: Relative variations of gate trigger current, holding current and latching current versus junction temperature



Information furnished in this document is believed to be accurate and reliable. However, Jiangsu JieJie Microelectronics Co.,Ltd assumes no responsibility for the consequences of use without consideration for such information nor use beyond it. Information mentioned in this document is subject to change without notice, apart from that when an agreement is signed, Jiangsu JieJie complies with the agreement. Products and information provided in this document have no infringement of patents. Jiangsu JieJie assumes no responsibility for any infringement of other rights of third parties which may result from the use of such products and information. This document is the eighth version which is made in 20-Feb.-2018. This document supersedes and replaces all information previously supplied.

 is a registered trademark of Jiangsu JieJie Microelectronics Co.,Ltd.

Copyright ©2018 Jiangsu JieJie Microelectronics Co.,Ltd. Printed All rights reserved.