

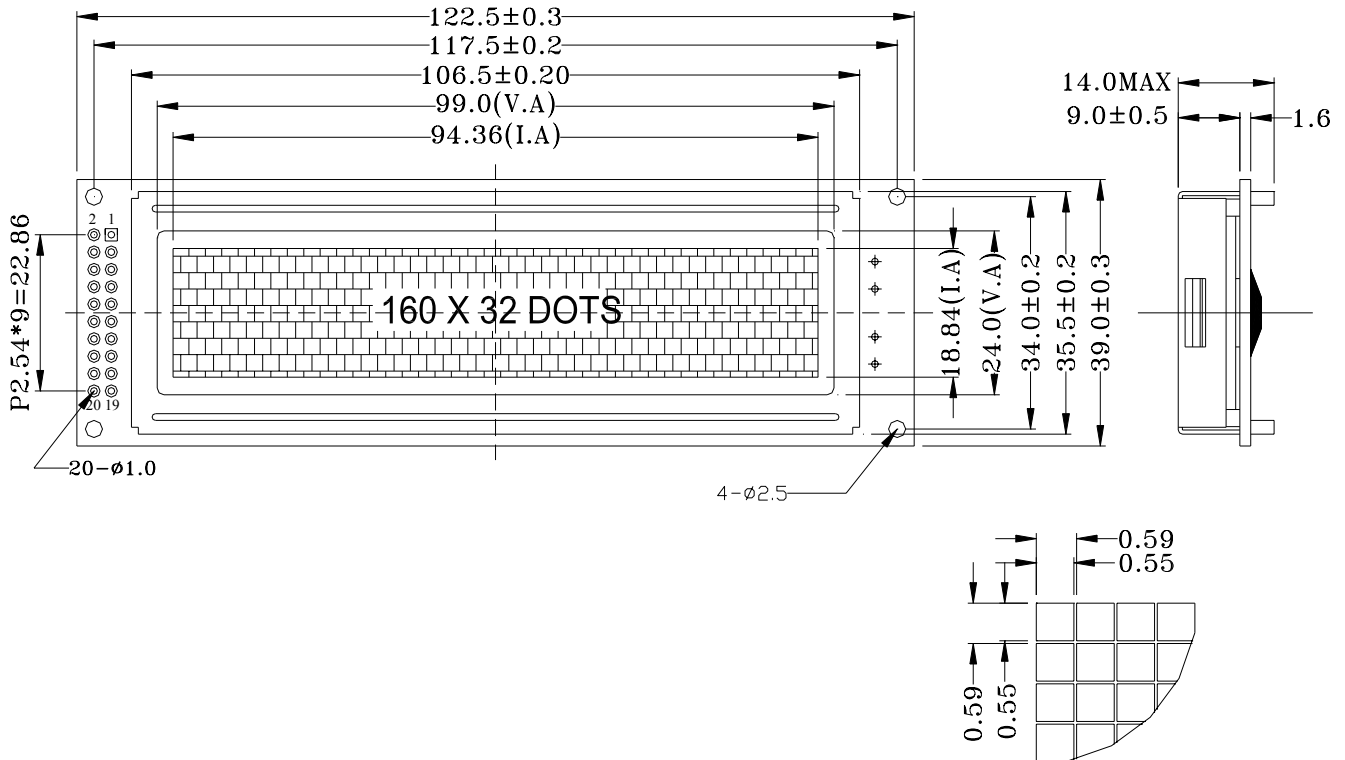

1 OUTLINE DIMENSION



2 PIN CONNECTIONS

NO.	SYMBOL	FUNCTION
1	A0	H: Data Input L: Instruction Code Input
2	CS2	Chip Selection For Segment IC2
3	CS1	Chip Selection For Segment IC1
4	E	Enable Signal
5	R/W	H: Data Read L: Data Write
6	VDD	Power Supply (+5V)
7	VSS	Ground (0V)
8-15	DB0-DB7	Data Bus
16	/RES	Reset
17	VO	Power Supply For LCD (VDD-VO=LCD Driving Voltage)
18	VEE	Negative Voltage Output (-10V)
19,20	LEDA,K	LED Supply Voltage (5V)

3 POWER SUPPLY

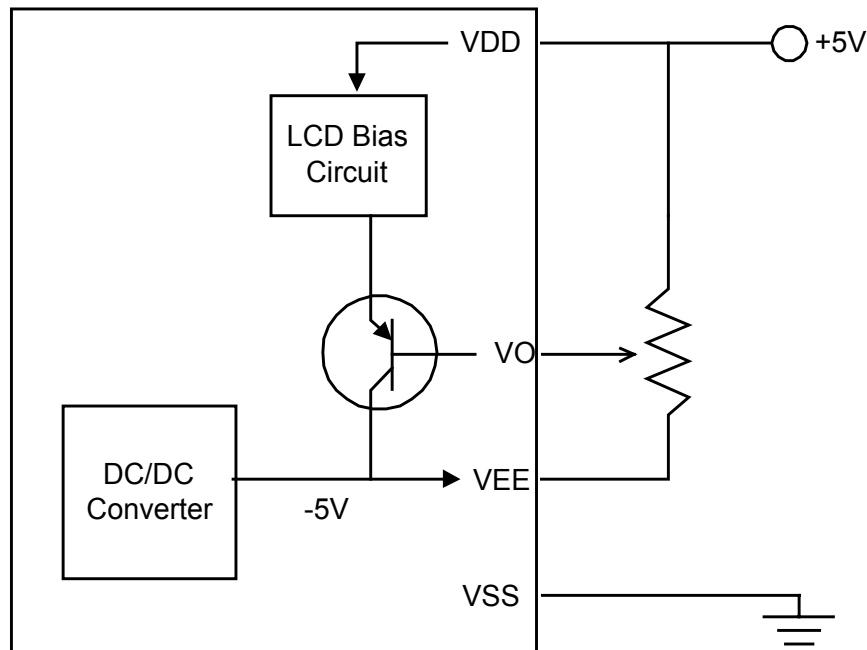

4 ELECTRO-OPTICAL CHARACTERISTICS

Parameter	Symbol	Condition	Min	Typ	Max	Unit	Note
----- Electronic Characteristics -----							
Logic Circuit Supply Voltage	VDD-VSS	--	4.5	5.0	5.5	V	
LCD Driving Voltage (Normal Temp. type)	VDD-VO	0 °C	--	--	--	V	
		25 °C	--	9.0	--		
		50 °C	--	--	--		
Input Voltage	VIH	--	0.7 VDD	--	VDD	V	
	VIL	--	VSS	--	0.3 VDD	V	
Logic Supply Current	IDD	VDD = 5V	--	1	2	mA	
----- Temperature Characteristics -----							
Normal temp. type	TOP	Operating Temp.	0		50	°C	
	TSTG	Storage Temp.	-10		60	°C	
Extended temp. type	TOP	Operating Temp.	-20		70	°C	
	TSTG	Storage Temp.	-30		80	°C	
----- LED Back-light Characteristics -----							
Forward Voltage	VF	--	3.8	4.2	4.5	V	
Forward Current	IF	VF=4.05V	--	360	--	mA	
Bare LED Luminous intensity		VF=4.05V	--	110	--	cd/m ²	
LCM Luminous intensity		VF=4.05V	--	30	--	cd/m ²	

* LED Dice number = 2x36=72