



JST04X 4A TRIACs

Rev.1.0

DESCRIPTION:

JST04X series provide high dv/dt rate with strong resistance to electromagnetic interface.

They are especially recommended for use on home appliances such as motor control of washing machine, and for use on industrial control systems like electromagnetic valves.

JST04X provides insulation voltage rated at 2000V RMS from all three terminals to external heatsink complying with UL standards (File ref: E252906).

MAIN FEATURES

Symbol	Value	Unit
$I_{T(RMS)}$	4	A
I_{GT1-3}	10	mA
V_{DRM}/V_{RRM}	800	V

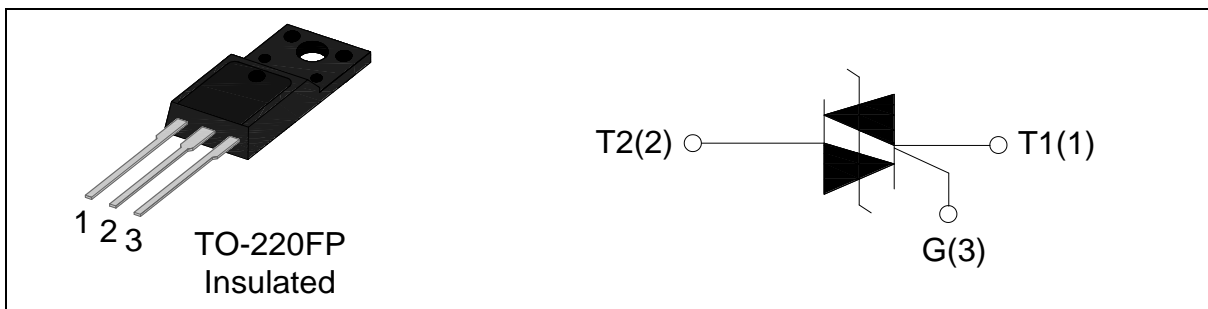

ABSOLUTE MAXIMUM RATINGS

Parameter	Symbol	Value	Unit
Storage junction temperature range	T_{stg}	-40-150	°C
Operating junction temperature range	T_j	-40-125	°C
Repetitive peak off-state voltage($T_j=25^{\circ}C$)	V_{DRM}	800	V
Repetitive peak reverse voltage($T_j=25^{\circ}C$)	V_{RRM}	800	V
Non repetitive surge peak Off-state voltage	V_{DSM}	$V_{DRM} + 100$	V
Non repetitive peak reverse voltage	V_{RSM}	$V_{RRM} + 100$	V
RMS on-state current	$I_{T(RMS)}$	4	A
Non repetitive surge peak on-state current (full cycle, F=50Hz)	I_{TSM}	40	A

I ² t value for fusing (tp=10ms)	I ² t	8	A ² s
Rate of rise of on-state current (I _G =2×I _{GT})	di/dt	50	A/μs
Peak gate current	I _{GM}	4	A
Average gate power dissipation	P _{G(AV)}	1	W
Peak gate power	P _{GM}	5	W

ELECTRICAL CHARACTERISTICS (T_j=25°C unless otherwise specified)

Symbol	Test Condition	Quadrant		Value	Unit
I _{GT}	V _D =12V R _L =33Ω	I - II -III	MAX	10	mA
V _{GT}		I - II -III	MAX	1.3	V
V _{GD}	V _D =V _{DRM} T _j =125°C R _L =3.3KΩ	I - II -III	MIN	0.2	V
I _L	I _G =1.2I _{GT}	I -III	MAX	20	mA
		II		40	
I _H	I _T =100mA		MAX	15	mA
dV/dt	V _D =2/3V _{DRM} Gate Open T _j =125°C		MIN	700	V/μs

STATIC CHARACTERISTICS

Symbol	Parameter		Value(MAX)	Unit
V _{TM}	I _{TM} =6A tp=380μs	T _j =25°C	1.5	V
I _{DRM}	V _D =V _{DRM} V _R =V _{RDM}	T _j =25°C	5	μA
I _{RDM}		T _j =125°C	0.5	mA

THERMAL RESISTANCES

Symbol	Parameter		Value	Unit
R _{th(j-c)}	junction to case(AC)	TO-220FP Ins	3.8	°C/W

ORDERING INFORMATION

J	ST	04	X	-800	SW
JieJie Microelectronics Co.,Ltd		Triacs			$I_{GT1-3} \leq 10mA$
		$I_{T(RMS)}:4A$		$800:V_{DRM} / V_{RRM} \geq 800V$	
			X: TO-220FP Ins		

PACKAGE MECHANICAL DATA

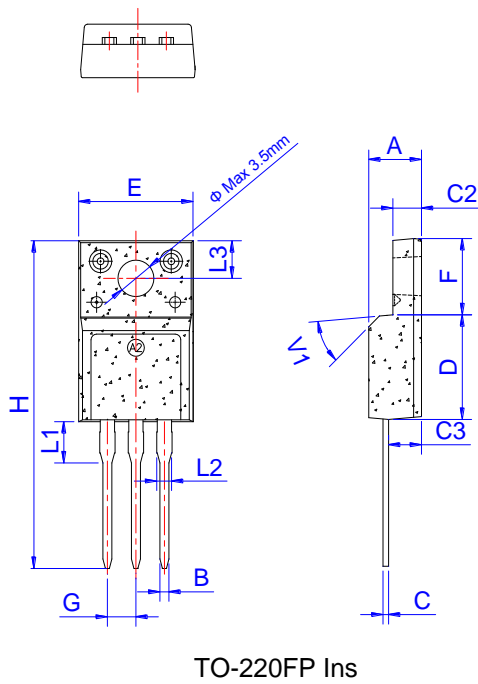

Ref.	Dimensions					
	Millimeters			Inches		
	Min.	Typ.	Max.	Min.	Typ.	Max.
A	4.50		4.90	0.177		0.193
B	0.74	0.80	0.83	0.029	0.031	0.033
C	0.47		0.65	0.019		0.026
C2	2.45		2.75	0.096		0.108
C3	2.60		3.00	0.102		0.118
D	8.80		9.30	0.346		0.366
E	9.80		10.4	0.386		0.410
F	6.40		6.80	0.252		0.268
G		2.54			0.1	
H	28.0		29.8	1.102		1.173
L1		3.63			0.143	
L2	1.14		1.70	0.045		0.067
L3		3.30			0.130	
V1		45°			45°	

FIG.1: Maximum power dissipation versus RMS on-state current

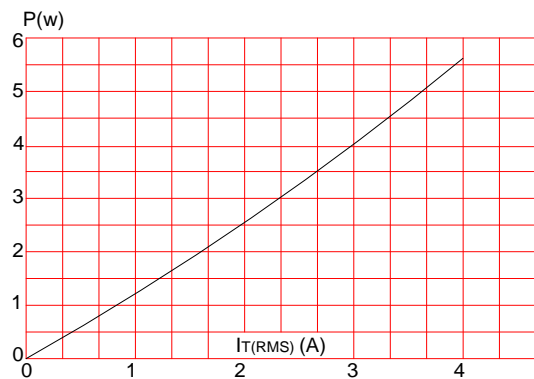

FIG.2: RMS on-state current versus case temperature

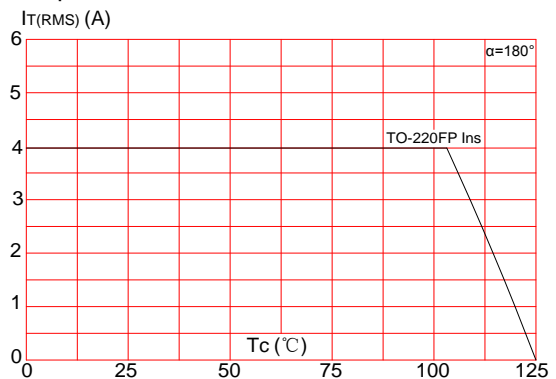

FIG.3: Surge peak on-state current versus number of cycles

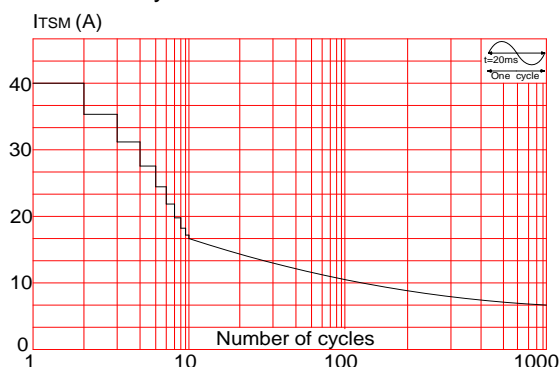

FIG.5: Non-repetitive surge peak on-state current for a sinusoidal pulse with width $t_p < 20\text{ms}$ and corresponding value of I^2t ($dI/dt < 50\text{A}/\mu\text{s}$)

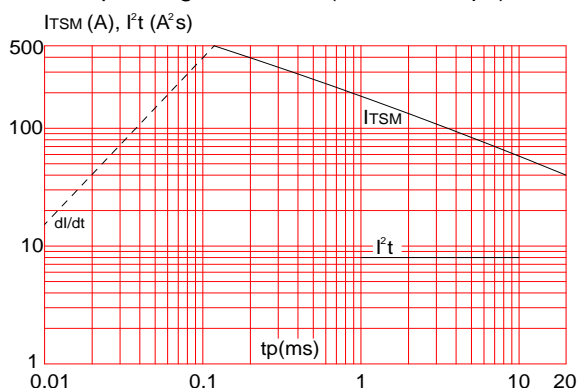

FIG.4: On-state characteristics (maximum values)

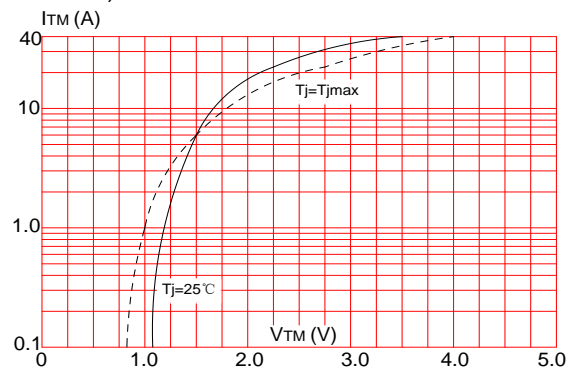
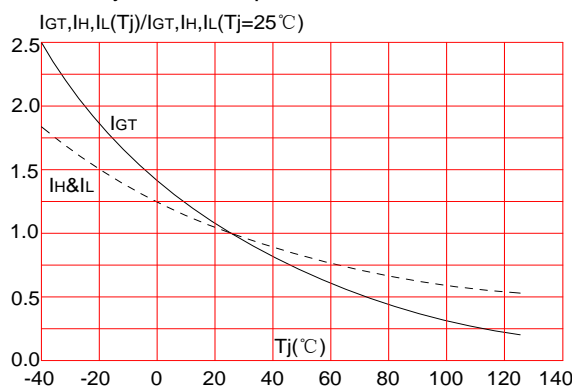



FIG.6: Relative variations of gate trigger current, holding current and latching current versus junction temperature



Information furnished in this document is believed to be accurate and reliable. However, Jiangsu JieJie Microelectronics Co.,Ltd assumes no responsibility for the consequences of use without consideration for such information nor use beyond it. Information mentioned in this document is subject to change without notice, apart from that when an agreement is signed, Jiangsu JieJie complies with the agreement. Products and information provided in this document have no infringement of patents. Jiangsu JieJie assumes no responsibility for any infringement of other rights of third parties which may result from the use of such products and information. This document is the first version which is made in 11-Jan.-2016. This document supersedes and replaces all information previously supplied.

 is a registered trademark of Jiangsu JieJie Microelectronics Co.,Ltd.

Copyright©2016 Jiangsu JieJie Microelectronics Co.,Ltd. Printed All rights reserved.