

JST40、JST41Z Series 40A TRIACs

DESCRIPTION:

High current density due to double mesa technology; SIPOS and Glass Passivation.

JST40、JST41Z Series triacs is suitable for general purpose AC switching. They can be used as an ON/OFF Function in applications such as static relays, heating regulation, induction motor starting circuits... or for phase control operation light dimmers, motorspeed controllers.

JST40-xxxxBW、JST41Z-xxxxBW Series are 3 Quadrants triacs, They are specially recommended for use on inductive loads.

JST40、JST41Z are isolated internally, they provides a 2500V RMS isolation voltage from all three terminals to external heatsink.

MAIN FEATURES

Symbol	Value	Unit
$I_T(RMS)$	40	A
V_{DRM}/V_{RRM}	600 / 800 / 1200 / 1600	V
V_{TM}	1.55	V

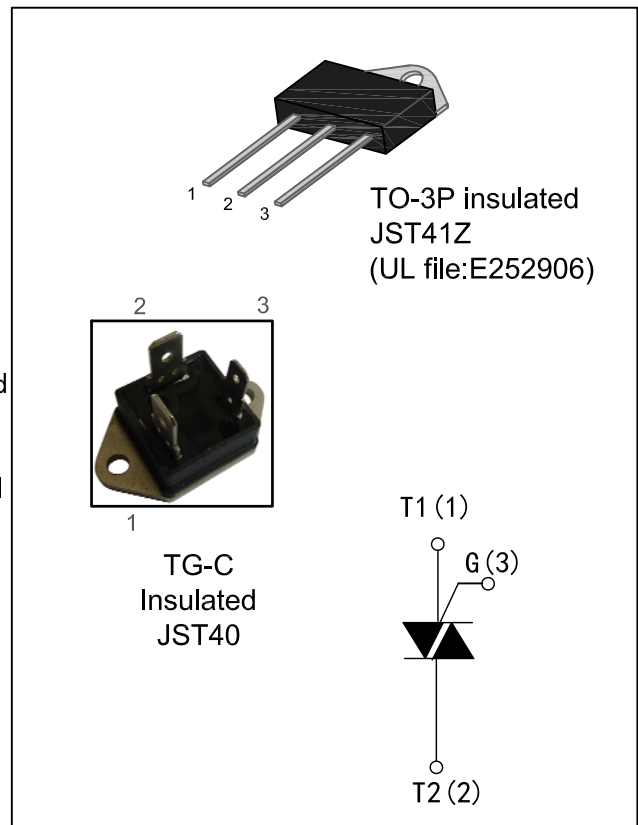

ABSOLUTE MAXIMUM RATINGS

Parameter		Symbol	Value	Unit
Storage junction temperature range		Tstg	-40 to +150	°C
Operating junction temperature range		Tj	-40 to +125	°C
Repetitive Peak Off-state Voltage Tj=25°C Repetitive Peak Reverse Voltage Tj=25°C	JST41Z-600XX、JST40-600XX	VDRM VRRM	600	V
	JST41Z-800XX、JST40-800XX		800	
	JST41Z-1200XX、JST40-1200XX		1200	
	JST41Z-1600XX、JST40-1600XX		1600	
Non repetitive Surge Peak Off-state Voltage	tp=10ms, Tj=25°C	VDSM	VDRM+100	V
Non repetitive Peak Reverse Voltage		VRRM	VRRM+100	
RMS on-state current (full sine wave)	TO-3P Tc=80°C	IT(RMS)	40	A
	TG-C Tc=90°C			
Non repetitive surge peak on-state current (full cycle, Tj=25°C)	f = 60 Hz t=16.7ms	ITSM	420	A
	f = 50 Hz t=20ms		400	
I²t Value for fusing	tp=10ms	I²t	880	A²s
Critical rate of rise of on-state current IG=2×IGT, tr≤100 ns, f=120Hz, Tj=125°C		di / dt	50	A/μs
Peak gate current	tp=20us, Tj=125°C	IGM	4	A
Peak Gate Power Dissipation	tp=20us, Tj=125°C	PGM	10	W
Average gate power dissipation	Tj=125°C	PG(AV)	1	W

ELECTRICAL CHARACTERISTICS(T_j=25°C unless otherwise specified)

Symbol	Test Condition	Quadrant		Limits		Unit
				BW	B	
I _{GT}	V _D =12V R _L =33Ω	I-II-III IV	MAX.	50 -	50 100	mA
V _{GT}		I-II-III IV	MAX.	1.3 -	1.3	V
V _{GD}	V _D =V _{DRM} R _L =3.3KΩ T _j =125°C	I-II-III IV	MIN.	0.2 -	0.2	V
I _L	I _G =1.2I _{GT}	I-II-III IV	MAX.	80 -	70	mA
		II	MAX.	100	90	mA
I _H	I _T =100mA		MAX.	60	60	mA
dV/dt	V _D =67%V _{DRM} gate open T _j =125°C		MIN.	1000	500	V/μs
(dl/dt) _c	Without snubber T _j =125°C		MIN.	20	5	A/ms

STATIC CHARACTERISTICS

Symbol	Parameter		Value(MAX.)	Unit
V _{TM}	I _{TM} =60A, t _p =380μs	T _j =25°C	1.55	V
I _{DRM} I _{RRM}	V _D =V _{DRM} V _R =V _{RRM}	T _j =25°C	10	μA
		T _j =125°C	5	mA

THERMAL RESISTANCES

Symbol	Parameter		Value	Unit
R _{th} (J-C)	Junction to Case(AC)	TO-3P	0.9	°C/W
		TG-C	0.8	

ORDERING INFORMATION

J ST 40 - 800 BW Jie Jie Microelectronics CO.,Ltd TRIAC SERIES I _{T(RMS)} : 40A TG-C Package	I_{GT} Class 600:V _{DRM} /V _{RRM} ≥600V 800:V _{DRM} /V _{RRM} ≥800V 1200:V _{DRM} /V _{RRM} ≥1200V 1600:V _{DRM} /V _{RRM} ≥1600V
--	---

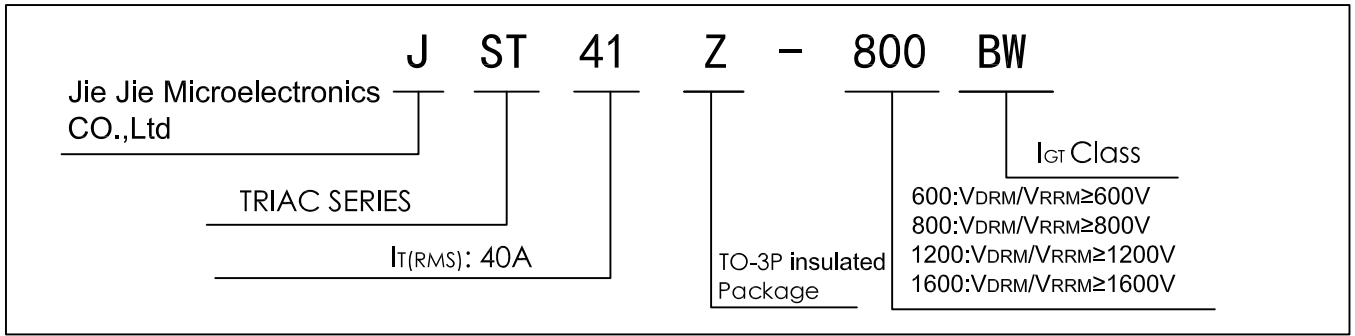

PACKAGE MECHANICAL DATA

TO-3P insulated Package

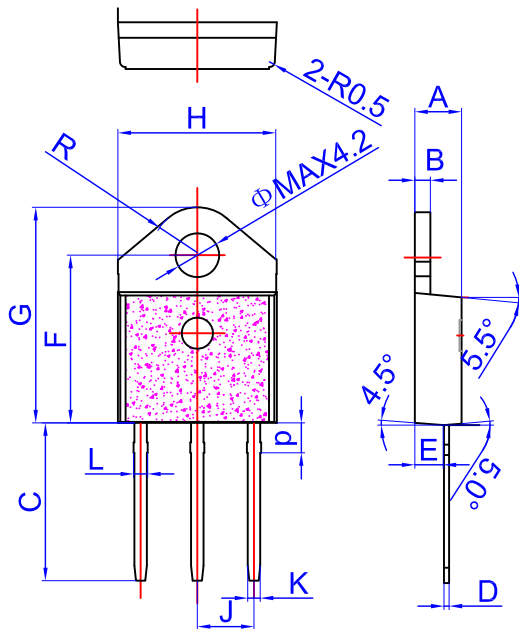

Ref.	Dimensions					
	Millimeters			Inches		
	Min.	Typ.	Max.	Min.	Typ.	Max.
A	4.4		4.6	0.173		0.181
B	1.45		1.55	0.057		0.061
C	14.35		15.6	0.565		0.614
D	0.5		0.7	0.020		0.028
E	2.7		2.9	0.106		0.114
F	15.8		16.5	0.622		0.650
G	20.4		21.1	0.815		0.831
H	15.1		15.5	0.594		0.610
J	5.4		5.65	0.213		0.222
K	1.2		1.4	0.047		0.055
L	1.35		1.50	0.053		0.059
P	2.8		3.0	0.110		0.118
R		4.6			0.181	

Marking:

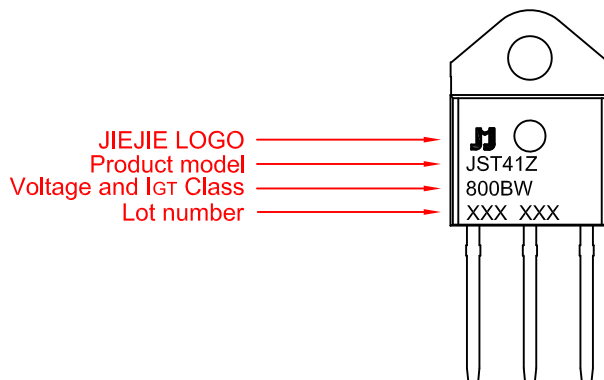

TG-C Package

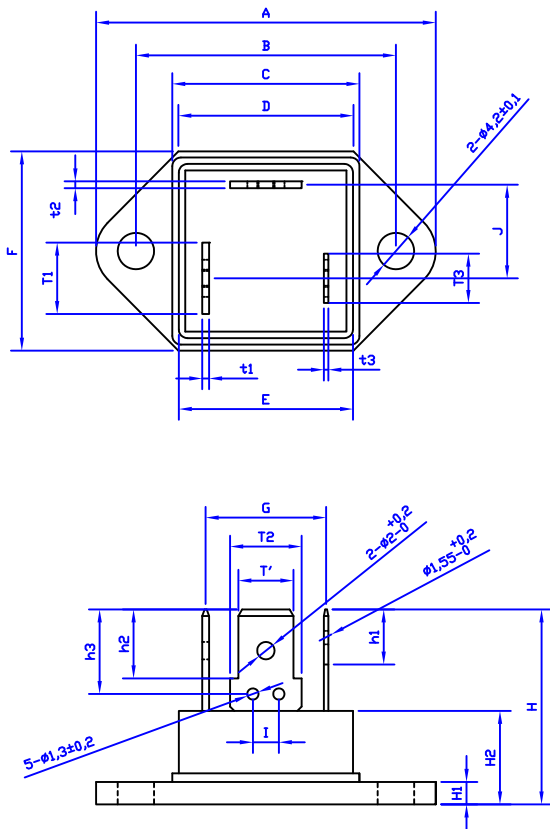

Ref.	Dimensions					
	Millimeters			Inches		
	Min.	Typ.	Max.	Min.	Typ.	Max.
A			39.2			1.543
B	29.8	30.0	30.2	1.173	1.181	1.189
C			21.6			0.85
D			20.2			0.795
E			20.1			0.791
F			23			0.906
T1、T2		8.25			0.325	
T3		5.7			0.224	
T'		6.35			0.25	
t1、t2		0.8			0.031	
t3		0.5			0.020	
G		13.9			0.547	
H1		2.6			0.102	
H2		10.8			0.425	
H			22.5			0.886
h1	6.2	6.35	6.5	0.244	0.25	0.256
h2	7.8	7.95	8.1	0.307	0.313	0.319
h3	9.45	9.75	10.05	0.372	0.384	0.396
I	2.7	3.0	3.3	0.106	0.118	0.130
J		10.8			0.425	

FIG.1:Maximum power dissipation versus RMS on-state current(full cycle)

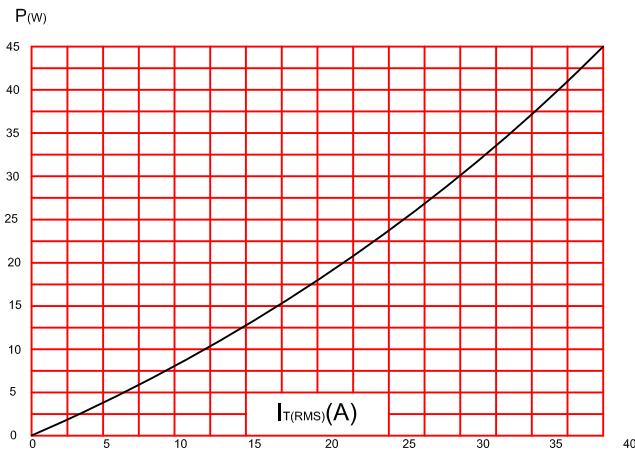

FIG.2:RMS on-state current versus case temperature(full cycle)

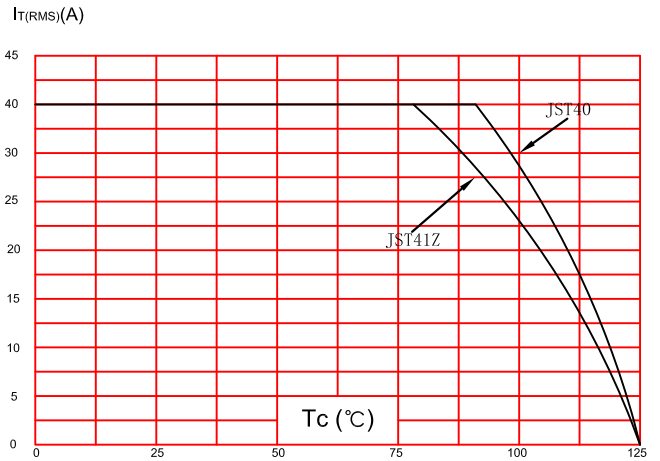

FIG.3:On-state characteristics (maximum values).

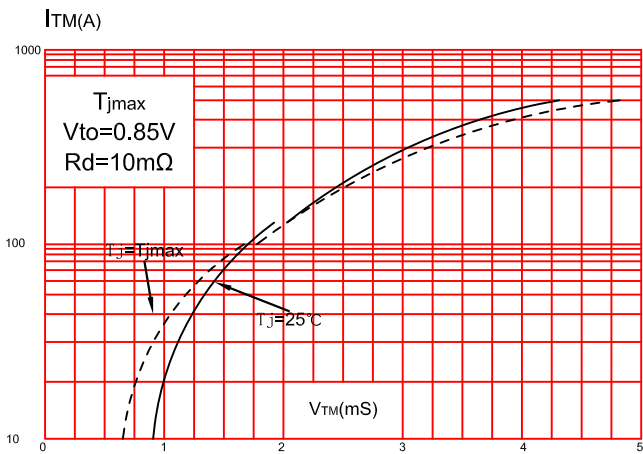

FIG.4:Surge peak on-state current versus number of cycles.

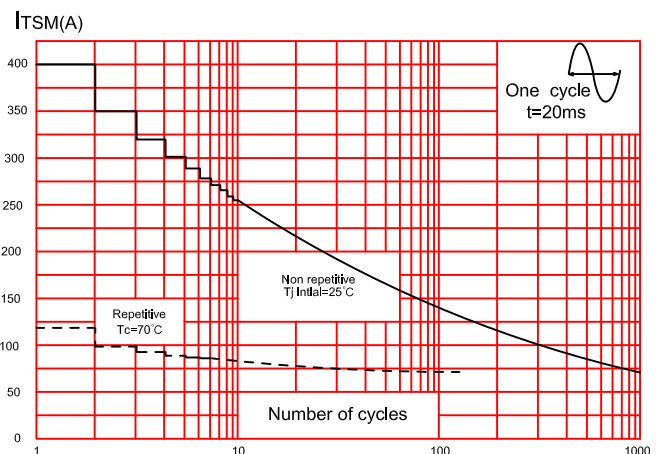

FIG.5:Non-repetitive surge peak on-state current for a sinusoidal pulse with width $t_p < 10ms$, and corresponding value of I^2t .

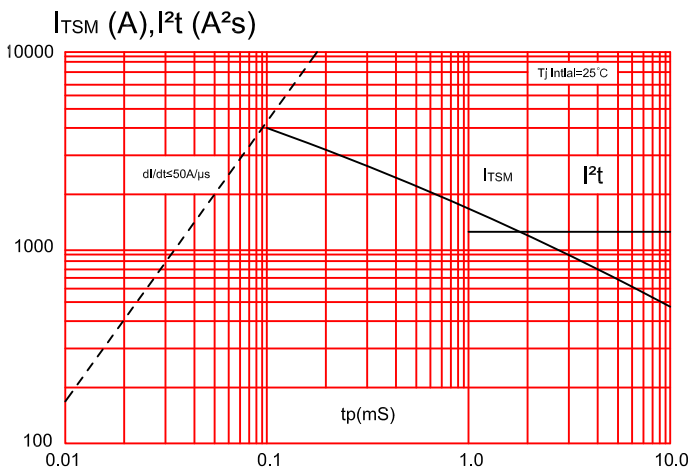

FIG.6:Relative variations of gate trigger current, holding current and latching current versus junction temperature(typical values)

