

JT92F

SUBMINIATURE HIGH POWER RELAY



 File No:E319069



Features

- 30A switching capability
- Creepage distance:8mm
- 4kV dielectric strength(between coil and contacts)
- UL insulation system:Class F
- Plastic sealed and dust protected types available
- PCB&QC layouts available
- Environmental friendly product (RoHS compliant)
- Outline Dimensions:(52.0 x 33.7 x 26.7)mm

CONTACT DATA

Contact arrangement	2A,2C
Contact resistance	50mΩ max.(at 1A 24VDC)
Contact material	AgSnO ₂ ,AgCdO
Contact rating (Res.load)	NO:30A 250VAC;30A 277VAC NC:3A 250VAC;3A 277VAC
Max. switching voltage	277VAC
Max. switching current	30A
Max. switching power	8310VA
Mechanical endurance	5 x 10 ⁶ OPS
Electrical endurance	1 x 10 ⁵ OPS(NO:30A 277VAC, Resistive load,Room temp 1s on 9s off) 1 x 10 ⁵ OPS(NC:3A 277VAC, Resistive load,Room temp 1s on 9s off)

CHARACTERISTICS

Insulation resistance	1000MΩ (at 500VDC)	
Dielectric strength	Between coil&contacts	4000VAC 1min
	Between open contacts	1500VAC 1min
	Between contact poles	2000VAC 1min
Surge voltage(between coil & contacts)	10kV(1.2/50 μ s)	
Operate time(at nomi. volt.)	DC type:25ms max.	
Release time(at nomi. volt.)	DC type:25ms max.	
Temperature rise(at nomi. volt.)	AC type:90K max. DC type:70K max.	
Shock resistance	Functional	98m/s ²
	Destructive	980m/s ²
Vibration resistance	10Hz to 55Hz 1.65mm DA	
Humidity	5% to 85% RH	
Ambient temperature	AC:-40°Cto 65°C DC:-40°Cto 85°C	
Termination	PCB, QC	
Unit weight	Approx. 86g	
Construction	Plastic sealed Flux proofed	

Notes: The data shown above are initial values.

COIL

Coil power	DC type:Approx. 1.7W; AC type:Approx. 4.0VA
------------	--

COIL DATA

at 23°C

DC type

Coil Code	Nominal Voltage VDC	Pick-up Voltage VDC max.	Dorp-out Voltage VDC min.	Max. Voltage VDC*	Coil Resistance Ω
005D	5	3.8	0.5	8.0	15.3x(1±10%)
006D	6	4.5	0.6	9.6	22x(1±10%)
012D	12	9	1.2	19.2	86x(1±10%)
024D	24	18	2.4	38.4	350x(1±10%)
048D	48	36	4.8	76.8	1390x(1±10%)
110D	110	82.5	12.0	176	7255x(1±10%)

AC type(at 50Hz)

Coil Code	Nominal Voltage VAC	Pick-up Voltage VAC max.	Dorp-out Voltage VAC min.	Max. Voltage VAC*	Coil Resistance Ω
024A5	24	19.2	4.8	26.4	45x(1±10%)
120A5	120	96	24	132	1125x(1±10%)
208A5	208	166.4	41.6	229	3278x(1±10%)
220A5	220	176	44	242	3800x(1±10%)
240A5	240	192	48	264	4500x(1±10%)
277A5	277	221.6	55.4	305	5960x(1±10%)

AC type(at 60Hz)

Coil Code	Nominal Voltage VAC	Pick-up Voltage VAC max.	Dorp-out Voltage VAC min.	Max. Voltage VAC*	Coil Resistance Ω
024A6	24	19.2	4.8	26.4	35.7x(1±10%)
120A6	120	96	24	132	830x(1±10%)
208A6	208	166.4	41.6	229	2600x(1±10%)
220A6	220	176	44	242	2870x(1±10%)
240A6	240	192	48	264	3800x(1±10%)
277A6	277	221.6	55.4	305	4700x(1±10%)



COIL DATA

at 23°C

AC type(at 50Hz/60Hz)

Coil Code	Nominal Voltage VAC	Pick-up Voltage VAC max.		Drop-out Voltage VAC min.		Max. Voltage VAC*	Coil Resistance Ω
		50Hz	60Hz	50Hz	60Hz		
120A	120	88	96	22	24	132	950 x (1 10%)
208A	208	160	166.4	40	41.6	229	2841 x (1 10%)
240A	240	176	192	44	48	264	3800 x (1 10%)
277A	277	200	221.6	50	55.4	305	5485 x (1 10%)

Notes: 1)*Maximum Voltage refers to the maximum voltage which relay coil could endure in a short period of time.

SAFETY APPROVAL RATINGS

UL/CUL	NO	30A 277VAC 1HP 120VAC 2.5HP 2400VAC 110LRA/25.3 FLA 240VAC(DC type)
	NC	3A 277VAC

Notes: 1)UL certified loads are tested at 40°C.

2)Only typical loads are listed above.Other load specifications can be available upon request.

ORDERING INFORMATION

JT92F - 012 -2C 2 2 F (XXX)

Type

Coil voltage
XXX D:DC type(5,6,12,24,48,110VDC)
XXX A5:AC type 50Hz(24,120,208,220,240,277VAC)
XXX A6:AC type 60Hz (24,120,208,220,240,277VAC)
XXX A:AC type 50Hz/60Hz(120,208,240,277VAC)

Contact arrangement **2A**: 2 Form A **2C**: 2 Form C

Termination¹⁾ **1**:PCB **2,3**:QC

Contact material **1**:AgSnO₂ **2**:AgCdO

Construction²⁾ **S**:Plastic sealed **F**:Flux proofed

Special code³⁾ **XXX**:Customer special requirement **Nil**:Standrad

Notes: 1) For terminals,no soldering or washing is allowed,For PCB terminals,please refer to us for soldering condition and part specification for necessary washing or surface processing after it is soldered to PCB.

2) We recommend dust protected types for a clean environment (free from contaminations like H₂S,SO₂,NO₂,dust,etc.).

We suggest to choose plastic sealed types and validate it in real application for an unclean environment(with contaminations)

3)The customer special requirement express as special code after evaluating by JINTIAN.

OUTLINE DIMENSIONS, WIRING DIAGRAM AND PC BOARD LAYOUT

Unit: mm

Outline Dimensions

1 Type (PCB)

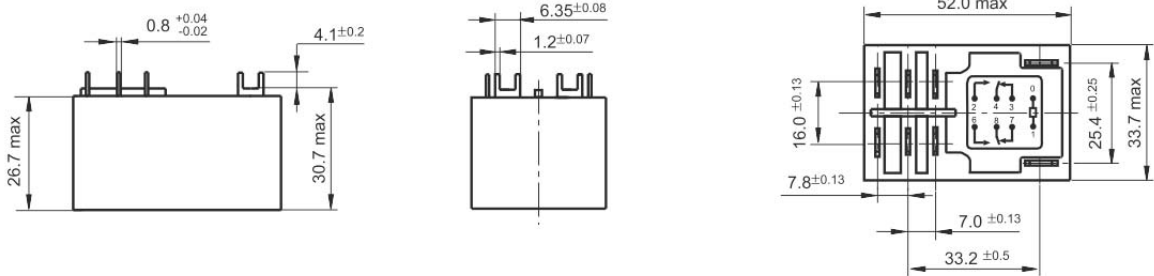

2 Type (QC)

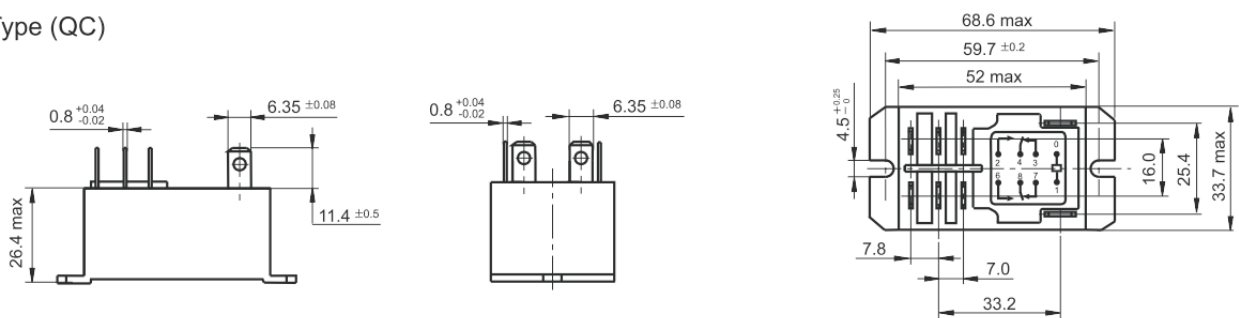

3 Type (QC)

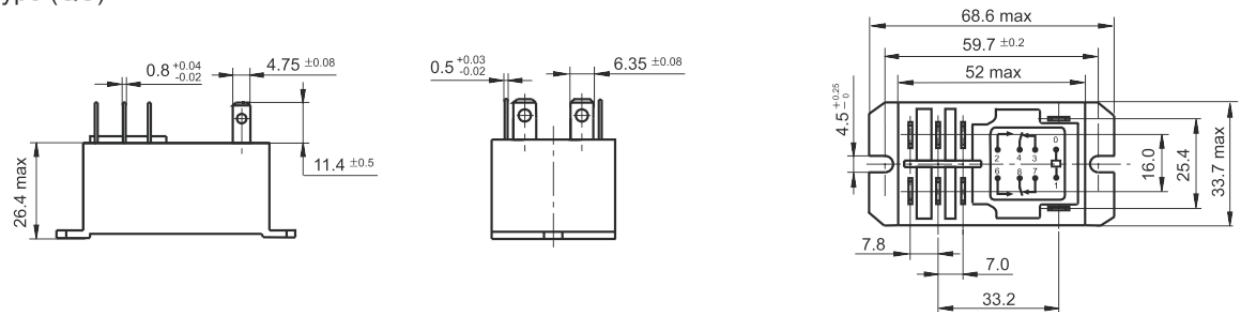

PCB Layout (Bottom view)

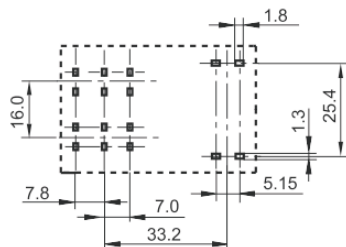

Wiring Diagram (Bottom view)

2 Form A

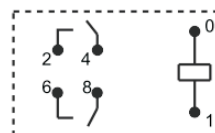

2 Form C

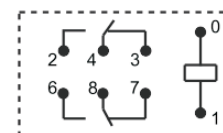

Remark: 1) In case of no tolerance shown in outline dimension: outline dimension ≤ 1 mm, tolerance should be ± 0.2 mm; outline dimension > 1 mm and ≤ 5 mm, tolerance should be ± 0.3 mm; outline dimension > 5 mm, tolerance should be ± 0.4 mm.
 2) The tolerance without indicating for PCB layout is always ± 0.1 mm.

CHARACTERISTIC CURVES

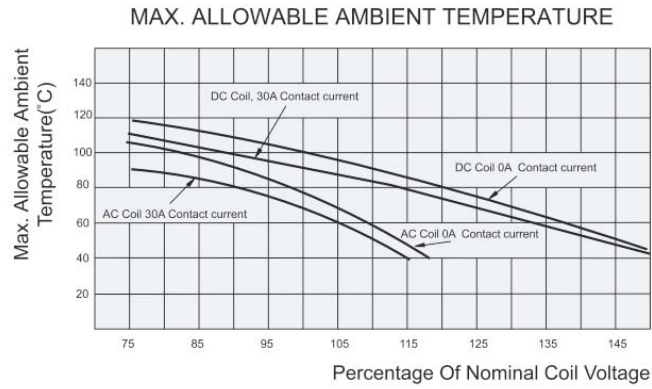

Disclaimer

The specification is for reference only. See to "Terminology and Guidelines" for more information. Specifications subject to change without notice. We could not evaluate all the performance and all the parameters for every possible application. Thus the user should be in a right position to choose the suitable product for their own application. If there is any query, please contact JINTIAN for the technical service. However, it is the user's responsibility to determine which product should be used only.