



actual size

# Quartz Crystal · JTX520

SMD Tuning Fork Crystal · 4.8 x 1.9 mm

www.DataSheet4U.com

- 32.768 kHz standard
- reflow soldering temperature: 260 °C max.
- package height 0.9 mm max.



## General Data

type	JTX 520
frequency	32.768 kHz (30.0 ~ 153.6 kHz on request)
frequency tolerance at 25 °C ± 5 °C	20 ppm / ± 30 ppm
load capacitance $C_L$	12.5 pF (7 pF ~ 12.5 pF)
temperature constant	-0.04 · 10 <sup>-6</sup> / °C <sup>2</sup> max. -0.034 · 10 <sup>-6</sup> / °C <sup>2</sup> typical
frequency temperature characteristic	$f$ (ppm) = -0.04 (25 °C - T) <sup>2</sup> T = requested temperature
operating temperature range	-20 °C ~ +70 °C / -40 °C ~ +85 °C
shunt capacitance $C_0$	1.3 pF typical
series resistance max. ( ESR )	50 kΩ typ. ( 80 kΩ max.)
storage temperature	-40 °C ~ +90 °C
drive level max.	1 μW
aging first year	< ± 3 ppm

## Frequency Stability vs. Temperature

		- 80 ppm	- 160 ppm	
-20 °C ~ +70 °C	STD.	●		
-40 °C ~ +85 °C	T1		●	
● standard				

## Marking

32.768 date code

date code:

A ~ M: Jan.- Dec.

5: 2005

6: 2006

7: 2007

Jan.	Febr.	Mar.	Apr.	May	June
A	B	C	D	E	F
July	Aug.	Sept.	Oct.	Nov.	Dec.
G	H	J	K	L	M

## Dimensions

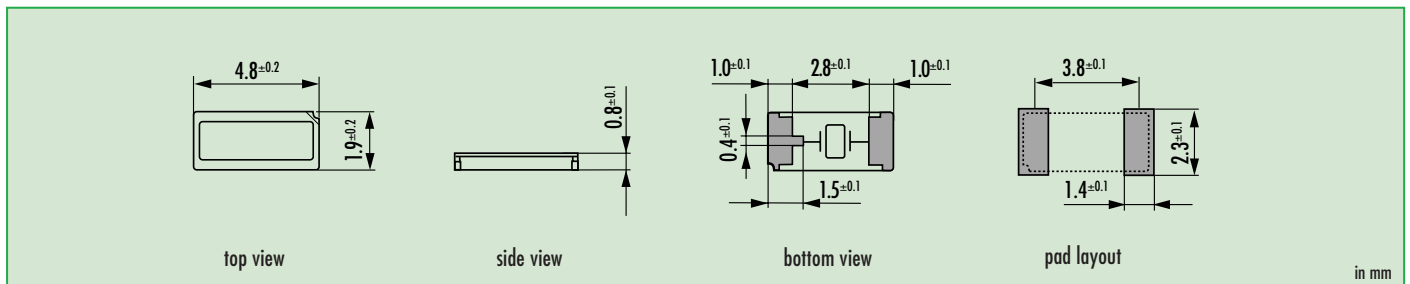

## Order Information

Q	frequency	type	load capacitance	stability at 25 °C	option
Quartz	0.032768 MHz	JTX520	7 ~ 12.5 pF 12.5 pF std.	20 = ± 20 ppm 30 = ± 30 ppm	blank = -20 °C ~ +70 °C T1 = -40 °C ~ +85 °C
Example: Q 0.032768-JTX520-12.5-30 (Suffix LF = RoHS compliant / Pb free pads)					

# Quartz Crystal · JTX520

www.DataSheet4U.com

## Taping Specification

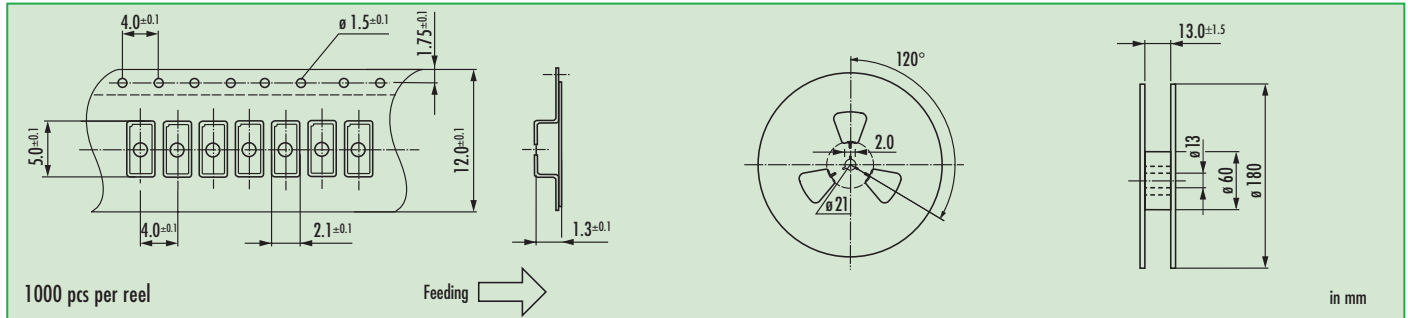

## Reflow Soldering Profile

