

40 Watts

- Renewable Energy, Industrial Applications and EV Applications
- Ultrawide Input Range - 200-1500 VDC
- Fully Encapsulated PCB Mount & DIN Rail Versions
- Optional DIN Rail Versions with Built In EMI Filter 1500 VDC Fuse
- -40 °C to +70 °C Operating Temperature
- 3 Year Warranty



The JVA series offers high isolation DC-DC converters with an ultra wide DC input range. Configuration options provide convenient installation choices.

Dimensions:

JVA40: 4.92 x 2.95 x 1.57" (124.9 x 74.9 x 40.0 mm)
JVA40-D: 5.08 x 4.02 x 1.92" (129.0 x 102.0 x 49.0 mm)
JVA40-DF: 5.75 x 5.43 x 2.17" (146.05 x 137.9 x 55.0 mm)

Models & Ratings

Output Power	Input Voltage	Output Voltage	Overvoltage Protection (typical)	Output Current	Input Current ⁽¹⁾	Typical Efficiency ⁽⁴⁾	Maximum Capacitive Load	Model Number ^(3,4)
40 W	200-1500 V	12.0 V	20.0 V	3330 mA	320 mA	76%	2000 µF	JVA401500S12
		15.0 V	20.0 V	2670 mA		78%	1200 µF	JVA401500S15
		24.0 V	30.0 V	1670 mA		80%	470 µF	JVA401500S24

Notes

1. At 200 VDC input
2. For DIN rail mount option, add suffix '-D' e.g. JVA401500S12-D
3. For DIN rail with added EMI filter option, add suffix '-DF' e.g. JVA401500S24-DF
4. At 800 VDC Input

Input

Characteristic	Minimum	Typical	Maximum	Units	Notes & Conditions
Input Voltage Range	200		1500	VDC	
Input Current		320/80/42		mA	200 VDC/800 VDC/1500 VDC input
Inrush Current		50/150		A	200 VDC/1500 VDC input
Input Filter	Pi type				
Undervoltage Lockout	On 180-195 V, Off 170-185 V				
Input Protection	External 15 A/1500 VDC fuse required				This is already included in the optional -DF version

Output

Characteristic	Minimum	Typical	Maximum	Units	Notes & Conditions
Output Voltage	12		24	V	See Models and Ratings table
Initial Set Accuracy		±2		%	
Minimum Load	0			A	No minimum load required
Start Up Delay		2		s	
Line Regulation		±1		%	
Load Regulation		±1		%	0 - 100% load
Ripple & Noise		150	300	mV pk-pk	20 MHz bandwidth
Short Circuit Protection					Trip & Restart (hiccup mode), auto recovery
Overload Protection	120		320	%	Trip & Restart (hiccup mode)
Overvoltage Protection					See Models and Ratings table
Temperature Coefficient		0.02		%/°C	

General

Characteristic	Minimum	Typical	Maximum	Units	Notes & Conditions
Efficiency		72		%	See Models and Ratings table
Isolation	4000			VAC	For 60 s
Switching Frequency		65		kHz	
Operating Altitude			5000	m	Derate from 100% load at 2000 m to 80% load at 5000 m
Mean Time Between Failure	300			kHrs	MIL-HDBK-217F, +25 °C GB
Weight		0.95 (434)		lb (g)	JVA40
		1.08 (494)			JVA40-D
		1.64 (744)			JVA40-DF

Environmental

Characteristic	Minimum	Typical	Maximum	Units	Notes & Conditions
Operating Temperature	-40		+70	°C	See derating curve
Storage Temperature	-40		+85	°C	
Case Temperature			95	°C	
Humidity	5		95	%RH	Non-condensing
Cooling					Natural convection
Shock	±3 shocks in each plane, total 18 shocks of 30 g : 11 ms halfsine. Conforms to EN60068-2-27 & EN60068-2-47				
Vibration	10-500 Hz at 2 g sweep and endurance at resonance in all 3 planes. Conforms to EN60068-2-6				

EMC: Emissions

Phenomenon	Standard	Test Level	Notes & Conditions
Conducted	EN55032	Level A	See application notes. Not required for '-DF' versions
Radiated	EN55032	Level A	

EMC: Immunity

Phenomenon	Standard	Test Level	Criteria	Notes & Conditions
Immunity	EN55024			
ESD Immunity	EN61000-4-2	±6 kV Contact, ±8 kV Air	A	
Radiated Immunity	EN61000-4-3	10 V/m	A	
EFT/Burst	EN61000-4-4	3	A	
Surges	EN61000-4-5	3	A	
Conducted Immunity	EN61000-4-6	10 Vrms	A	
Magnetic Fields	EN61000-4-8	10 A/m	A	

Safety Approvals

Safety Agency	Safety Standard	Notes & Conditions
EN	EN62109	Photovoltaic Power System
UL	UL1741/CSA-C22.2 No.107-1	Distributed Energy Resources

Application Notes

Thermal Derating Curve

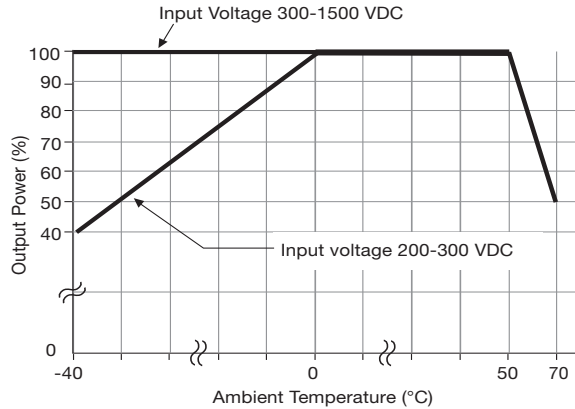

Input Derating Curve

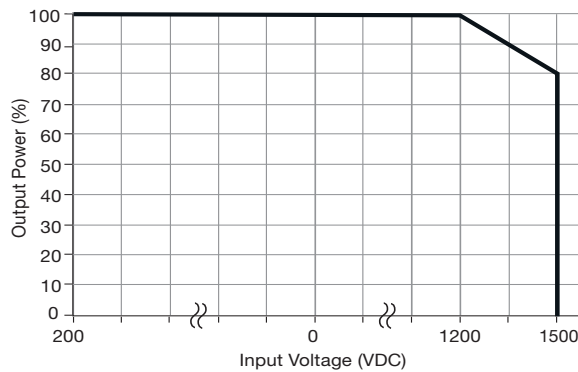

EMI Filter for Conducted Emissions

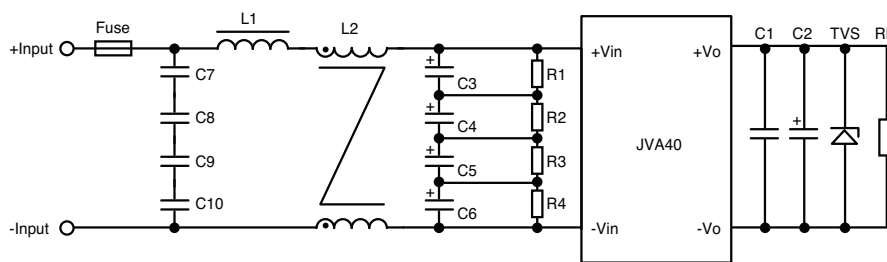

Model	C1 (μF)	C2 (μF)	TVS
JVA401500S12	1	120	SMBJ20A
JVA401500S15		120	SMBJ20A
JVA401500S24		68	SMBJ30A

Element Model	Recommended Value
C7/C8/C9/C10	104K/275 VAC
C3/C4/C5/C6	47 μF/450 VDC
R1/R2/R3/R4	1 MΩ/2 W
L1	330 μH/1 A
L2	7 mH/1 A
Fuse	15 A/1500 VDC

Mechanical Details

Standard PCB Mount

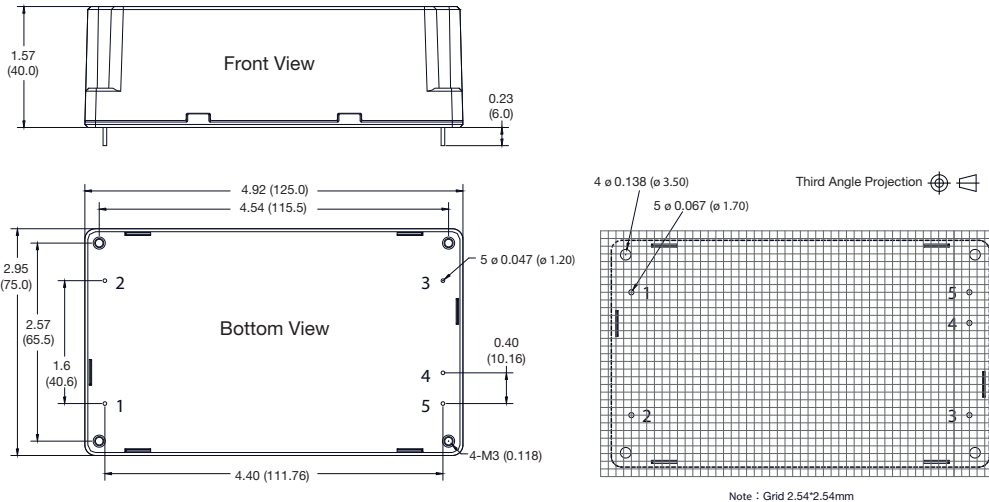

Pin Connections	
Pin	Function
1	-Vin
2	+Vin
3	No Connection
4	-Vo
5	+Vo

Optional DIN rail mount, -D

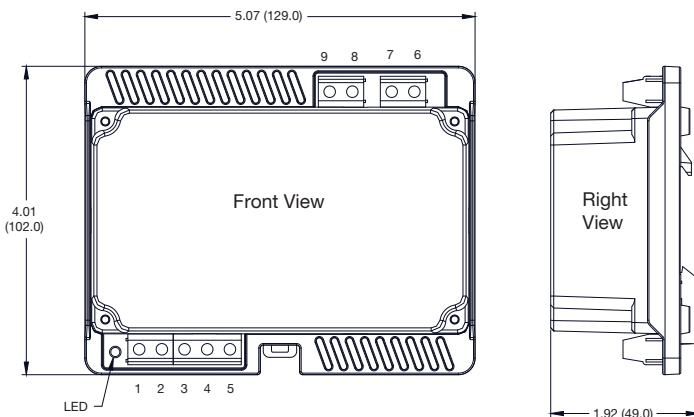

Pin Connections	
Pin	Function
1	+Vo
2	-Vo
3	No Connection
4	No Connection
5	No Connection
6	+Vin
7	+Vin
8	-Vin
9	-Vin

Optional DIN rail mount with filter, -DF

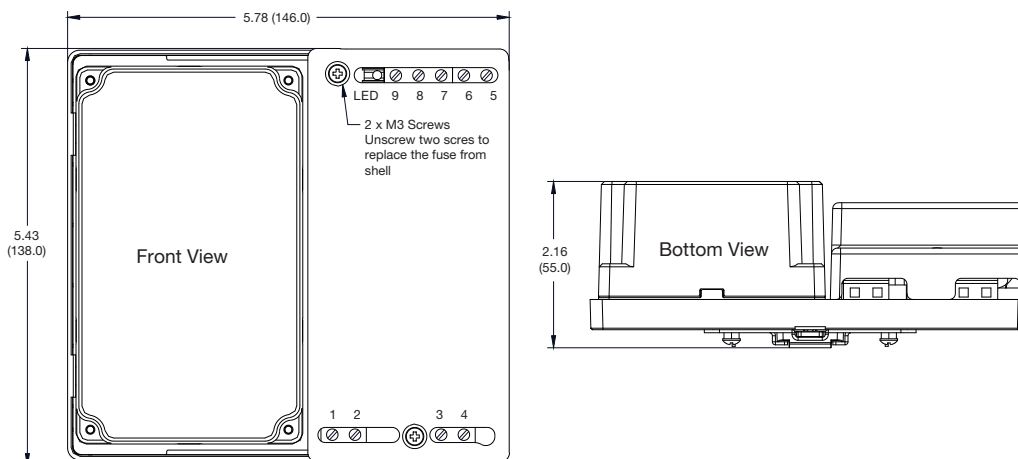

Pin Connections	
Pin	Function
1	-Vin
2	-Vin
3	+Vin
4	+Vin
5	+Vo
6	-Vo
7	No Connection
8	No Connection
9	No Connection

Notes

1. All dimensions are in inches (mm)

2. Weight: Standard PCB mount: 0.903 lbs (410 g) approx
 Optional DIN rail mount, -D: 1.04 lbs (470 g) approx
 Optional DIN rail mount with filter, -DF: 1.59 lbs (720 g) approx