

Parameters Subject to Change Without Notice

DESCRIPTION

The JW1760 is a constant current LED controller with high current accuracy which applies to single stage step-down LED drivers.

High accuracy of output current is achieved by sensing the output current directly. Critical conduction mode operation reduces the switching losses and significantly increases the efficiency. JW1760 can be supplied from the output directly, and auxiliary winding is not needed.

JW1760 has multi-protection functions which largely enhance the safety and reliability of the system, including VCC over-voltage protection, VCC UVLO, short-circuit protection, LED open protection, cycle-by-cycle current limit and over-temperature protection.

FEATURES

- No Auxiliary Winding
- Good Line and Load Regulation (<+-1%)
- Critical Conduction Mode
- High Efficiency over universal input range
- Cycle-by-cycle Current Limit
- LED Short Protection
- LED Open Protection
- Over Temperature Protection
- SOT23-5 Package

APPLICATION

- LED Driver

TYPICAL APPLICATION

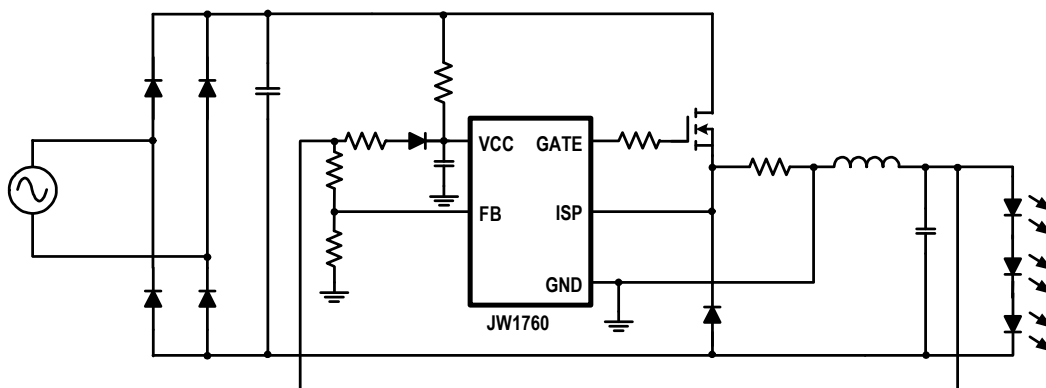

ORDER INFORMATION

LEAD FREE FINISH	TAPE AND REEL	PACKAGE	TOP MARKING
JW1760SOTA#PBF	JW1760SOTA#TRPBF	SOT23-5	1760

Note:

JWXXXXPPPP#TRPBF
 Part Number Package Code Tape and Reel (If "TR" is not shown, it means Tube) Pb Free

PIN CONFIGURATION

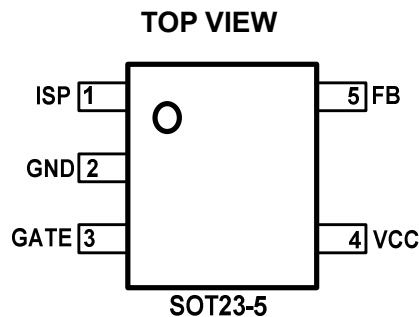

ABSOLUTE MAXIMUM RATING¹⁾

VCC Pin	43V
GATE Pin	18V
Other Pins	-0.3V to 4.5V
Junction Temperature ^{2) 3)}	150°C
Lead Temperature.....	260°C
Storage Temperature.....	-65°C to +150°C

RECOMMENDED OPERATING CONDITIONS

VCC PIN.....	8V to 43V
FB PIN	1.6V to 2.6V
Junction Temperature (T _J)	-40°C to 125°C

THERMAL PERFORMANCE⁴⁾

	θ_{JA}	θ_{JC}
SOT23-5	220	130°C/W

Note:

- Exceeding these ratings may damage the device.
- The JW1760 guarantees robust performance from -40°C to 150°C junction temperature. The junction temperature range specification is assured by design, characterization and correlation with statistical process controls.
- The JW1760 includes thermal protection that is intended to protect the device in overload conditions. Thermal protection is active when junction temperature exceeds the maximum operating junction temperature. Continuous operation over the specified absolute maximum operating junction temperature may damage the device.
- Measured on JE51-7, 4-layer PCB.

ELECTRICAL CHARACTERISTICS

<i>V_{IN} = 20V, T_A = 25°C, unless otherwise stated.</i>						
Item	Symbol	Condition	Min.	Typ.	Max.	Units
V _{CC} Turn-On Voltage	V _{CC_ON}			14.6		V
V _{CC} Turn-Off Voltage	V _{CC_OFF_L}			7.7		V
V _{CC} Hysteresis	V _{CC_HYS}	V _{CC_ON} - V _{CC_OFF_L}		6.9		V
V _{CC} Over-Voltage Threshold	V _{CC_OVTH}			35		V
V _{CC} Shunt Regulator Current Limit	I _{CC_SHUNT}	V _{CC} = 58V		5		mA
V _{CC} Quiescent Current	I _Q	V _{CC} < V _{CC_ON}		26		uA
FB Over-Voltage Threshold	V _{FB_H}			3		V
V _{ISP} Reference Voltage	V _{ISP}			100		mV
Gate Output High	V _{GATE_H}			13.2		V
Leading Edge Blanking Time	T _{LEB}			1000		ns
Maximum Frequency	F _{MAX}			120		kHz
Gate Driver Rise Time	T _{GATE_R}	C _L =1nF 10% to 90%		20		ns
Gate Driver Fall Time	T _{GATE_F}	C _L =1nF 90% to 10%		20		ns