

DESCRIPTION

The JW1964B/JW1964C/JW1964D (JW1964X series) is a constant voltage controller with high voltage accuracy which applies to single stage boost power factor corrected(PFC) applications. The constant on time control strategy ensures high power factor, and the input voltage detection circuit is not needed, which simplifies the system design and saves the loss.

The critical conduction mode operation reduces the switching losses, improves the EMI performance and increases the efficiency.

JW1964X series has multi-protection functions which largely enhance the safety and reliability of the system, including VCC UVLO, ISP over voltage protection, open feedback protection, FB over voltage protection and over-temperature protection.

Company's Logo is Protected, "JW" and "JOULWATT" are Registered Trademarks of Joulwatt Technology Co., Ltd.

FEATURES

- Low Quiescent Current
- High Power Factor and Low THD
- Critical Conduction Mode
- High Voltage Power MOSFET Integrated
- High Reference Voltage Accuracy
- High Efficiency Over Wide Operating Range
- Open Feedback Protection
- Disable Function
- Pulse by Pulse Current Limit
- FB Over Voltage Protection
- ISP Over Voltage Protection
- Internal Over-temperature Protection
- SOP8 Package

APPLICATIONS

- SMPS
- AC-DC Adapter
- Flat TV

TYPICAL APPLICATION

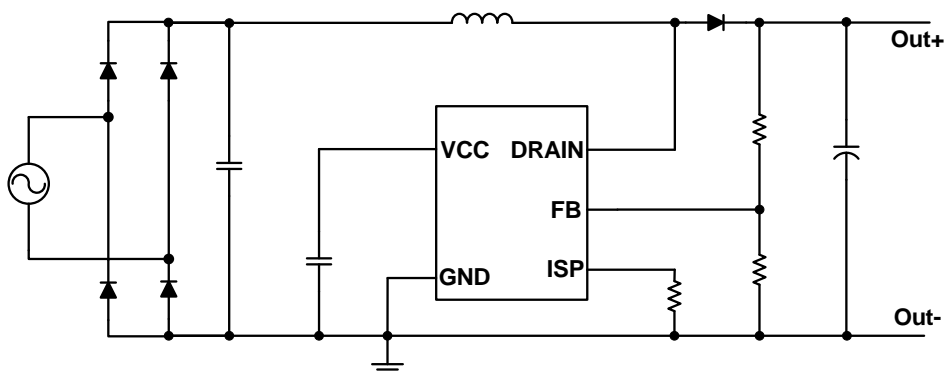

ORDER INFORMATION

DEVICE ¹⁾	PACKAGE	TOP MARKING ²⁾	ENVIRONMENTAL ³⁾
JW1964BSOPB#TR	SOP8	JW1964B YW□□□□□	Green
JW1964CSOPB#TR	SOP8	JW1964C YW□□□□□	Green
JW1964DSOPB#TR	SOP8	JW1964D YW□□□□□	Green

Notes:

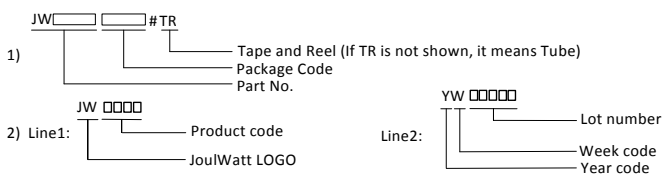

3) All JoulWatt products are packaged with Pb-free and Halogen-free materials and compliant to RoHS standards.

DEVICE INFORMATION

DEVICE	MOS RDSON
JW1964BSOPB#TR	5.5Ω
JW1964CSOPB#TR	2.8Ω
JW1964DSOPB#TR	2Ω

PIN CONFIGURATION

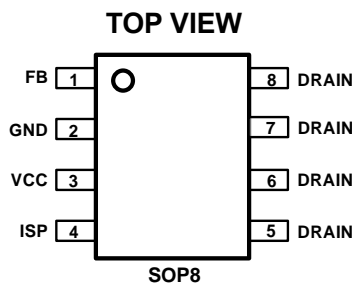

ABSOLUTE MAXIMUM RATING¹⁾

VCC Current	7mA
DRAIN Voltage.....	500V
All Other Pins.....	.5 V
Junction Temperature ^{2) 3)}	150°C
Lead Temperature.....	260°C

Storage Temperature..... -65°C to 150°C

RECOMMENDED OPERATING CONDITIONS

DRAIN Voltage.....30V~400V

Operating Junction Temperature (T_J)..... -40°C to 125°C

THERMAL PERFORMANCE⁴⁾

θ_{JA} θ_{JC}

SOP8.....96.....54°C/W

Note:

- 1) Exceeding these ratings may damage the device. These stress ratings do not imply function operation of the device at any other conditions beyond those indicated under RECOMMENDED OPERATING CONDITIONS.
- 2) The JW1964X series includes thermal protection that is intended to protect the device in overload conditions. Continuous operation over the specified absolute maximum operating junction temperature may damage the device.
- 3) The device is not guaranteed to function outside of its operating conditions.
- 4) Measured on JESD51-7, 4-layer PCB.

ELECTRICAL CHARACTERISTICS

<i>T_A=25 °C, unless otherwise stated.</i>							
Item	Symbol	Condition	Min.	Typ.	Max.	Units	
Power Supply							
VCC Start-up Voltage	V _{CC_ST}		13.4	14.1	14.8	V	
VCC Under Voltage Lockout	V _{CC_UVLO}		8.1	8.5	8.9	V	
VCC Operational Current at Disable	I _{VCC_DIS}			49	62	µA	
VCC Start-up Supply Current	I _{VCC_ST}	V _{CC} =8V		21	62	µA	
VCC Over Voltage Threshold	V _{CC_OVP}		28.3	29.7	31.1	V	
VCC Shunt Current ⁵⁾	I _{SHUNT}	V _{CC} =V _{CC_OVP} + 0.5V		10		mA	
Voltage Regulation							
ISP Clamp Voltage	V _{ISP_MAX}		466	495	524	mV	
FB Reference Voltage	V _{FB_REF}		2.45	2.5	2.55	V	
FB Start-up Voltage	V _{FB_ST}		370	402	434	mV	
FB Quick Start-up Voltage	V _{FB_QST}		2.17	2.28	2.39	V	
FB Quick Start-up Hysteresis ⁵⁾	V _{FB_QST_HYST}			0.12		V	
Maximum On Time of MOSFET	T _{ON_MAX}		34	36	38	µs	
Minimum On Time of MOSFET ⁵⁾	T _{ON_MIN}		0.43	0.5	0.57	µs	
Maximum Off Time of MOSFET	T _{OFF_MAX}		44	62	80	µs	
Minimum Off Time of MOSFET ⁵⁾	T _{OFF_MIN}			0.85		µs	
Maximum Switching Frequency	F _{MAX}		185	240	340	kHz	
MOSFET							
MOSFET R _{dson} ⁵⁾	JW1964B	R _{dson}	V _{gs} =10V		5.5	7.5	Ω
	JW1964C				2.8	3.5	
	JW1964D				2	2.5	
MOSFET Breakdown Voltage	BV	V _{gs} =0V	500			V	
Protection							
ISP OVP Threshold	V _{ISP_OVP}		1.41	1.48	1.55	V	
OVP Threshold at FB Pin	V _{FB_OVP}		2.59	2.68	2.77	V	
FB OVP Hysteresis	V _{FB_OVP_HYST}		0.126	0.18	0.234	V	
Thermal Protection Threshold ⁵⁾	T _{OTP}			140		°C	
Thermal Protection Hysteresis ⁵⁾	T _{OTP_HYST}			30		°C	

Note:

5) Guaranteed by design.

PIN DESCRIPTION

Pin No.	Name	Description
1	FB	Output voltage feedback pin.
2	GND	Chip ground.
3	VCC	Power supply.
4	ISP	Current detection pin.
5, 6, 7, 8	DRAIN	Drain of the power MOSFET.

BLOCK DIAGRAM

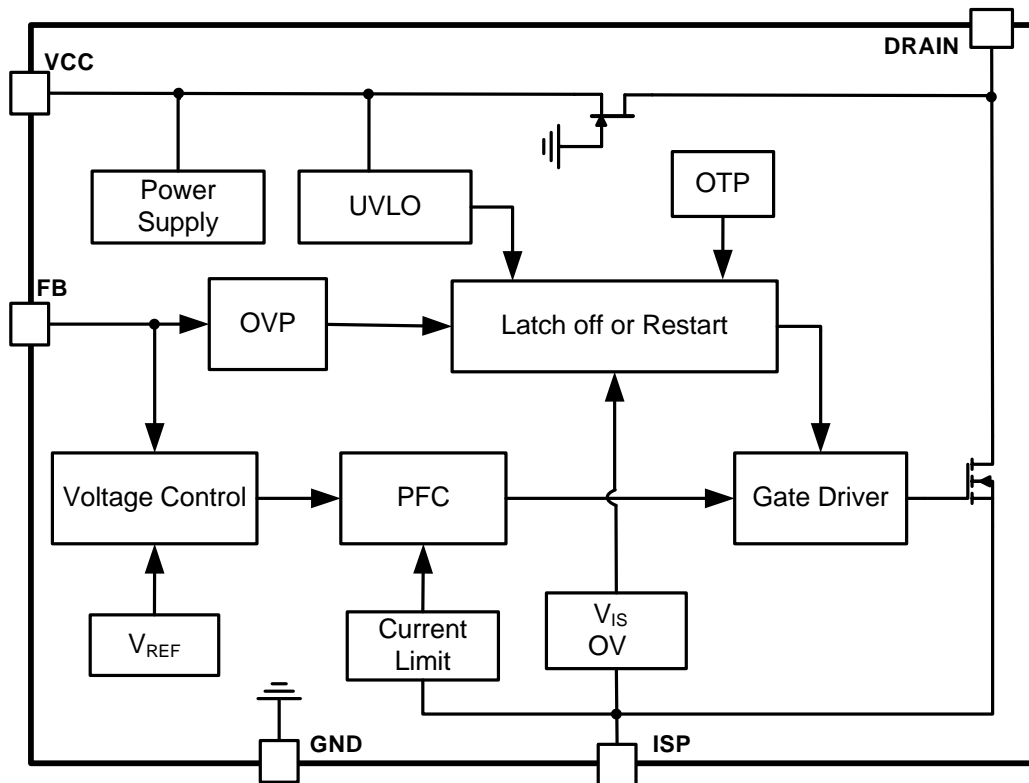

FUNCTIONAL DESCRIPTION

The JW1964X series is a constant voltage(CV) regulator which applies to boost system with power factor correction. JW1964X series can achieve excellent line and load regulations, high efficiency and low system cost with few peripheral components.

Start Up

When VCC is charged to VCC Start-up Voltage(V_{CC_ST}), the GATE driver begins to switch. When VCC is higher than VCC Over Voltage Threshold(V_{CC_OVP}), VCC shunt current is enabled to prevent VCC from being too high. When VCC is lower than VCC Under Voltage Lockout(V_{CC_UVLO}), the chip stops switching.

Quick Start-up Function

JW1964X series enters into quick start up mode when V_{FB} is lower than FB Quick Start-up Voltage(V_{FB_QST}). I_{PK} is I_{PK_MAX} unless T_{ON} reaches Maximum ON Time(T_{ON_MAX}), which accelerates the start up process and decreases the voltage drop in light to heavy load transient. JW1964X series quits this mode when V_{FB} is larger than V_{FB_QST}+ V_{FB_QST_HYST}.

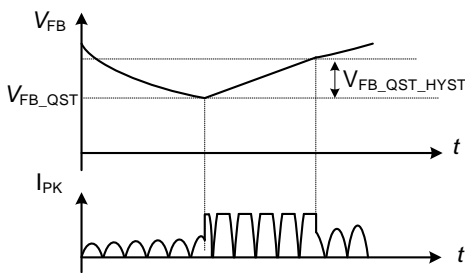

Constant Voltage Control

JW1964X series controls the output voltage from the information of FB pin. The output voltage is

$$V_O = V_{FB_REF} \times (R_{FB1} + R_{FB2}) / R_{FB2}$$

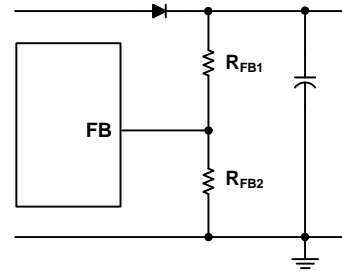

Where,

V_{FB_REF} – The FB Reference Voltage;
R_{FB1}, R_{FB2} – FB divide resistors.

Critical Conduction Mode Operation

JW1964X series works in the critical conduction mode of the inductor current. When the power MOSFET is turned on, the inductor current increases from zero. The turn on time of the MOSFET can be calculated as:

$$T_{ON} = I_{PK} \times L / V_{IN}$$

Where,

L – Inductance;
V_{IN} – Input voltage.

I_{PK} is the peak current in one switching period and the maximum value(I_{PK_MAX}) is limited by the MOSFET current sensing resistor(R_{ISP}).

$$I_{PK_MAX} = V_{ISP_MAX} / R_{ISP}$$

Where,

V_{ISP_MAX} – ISP Clamp Voltage.

When the power MOSFET is turned off, the inductor current begins to decrease. The power MOSFET turns on again when the inductor current is zero. The turn off time of the MOSFET can be calculated as:

$$T_{OFF} = I_{PK} \times L / (V_{OUT} - V_{IN})$$

Where,

V_{OUT} – Output voltage.

The power inductance can be calculated as:

$$L = V_{IN} \times (V_{OUT} - V_{IN}) / (f \times I_{PK} \times V_{OUT})$$

Where, f is the switching frequency of the boost system.

Disable Function

The FB pin can also be used for device disabling. If V_{FB} is pulled down and lower than FB Start-up Voltage(V_{FB_ST}), JW1964X series stops switching and enters in green mode which reduces the power consumption. JW1964X series will restart if $V_{FB} > V_{FB_ST}$.

ISP Over Voltage Protection

Normally the maximum V_{ISP} is clamped to V_{ISP_MAX} , but V_{ISP} is very high if the inductor or the freewheeling diode is shorted. When V_{ISP} is higher than ISP OVP Threshold(V_{ISP_OVP}), ISP over voltage protection is triggered and JW1964X series stops switching for 800mS.

FB Over Voltage Protection

The over voltage protection is triggered if V_{FB} is over than FB Over Voltage Protection Threshold(V_{FB_OVP}). The internal comp will be reset and the power MOSFET gate driver stops switching unless FB voltage is decreased to $V_{FB_OVP} - V_{FB_OVP_HYST}$.

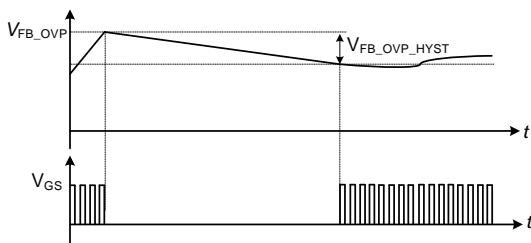

Over Temperature Protection

When internal temperature of the chip exceeds the Over Thermal Protection Threshold(T_{OTP}), JW1964X series stops switching unless the junction temperature is decreased to $T_{OTP} - T_{OTP_HYST}$.

PCB Design

When designing the PCB system, please follow the directions:

1. The VCC pin must be locally bypassed with a capacitor.
2. Make the area of the power loop as small as possible in order to reduce the EMI radiation.

PACKAGE OUTLINE

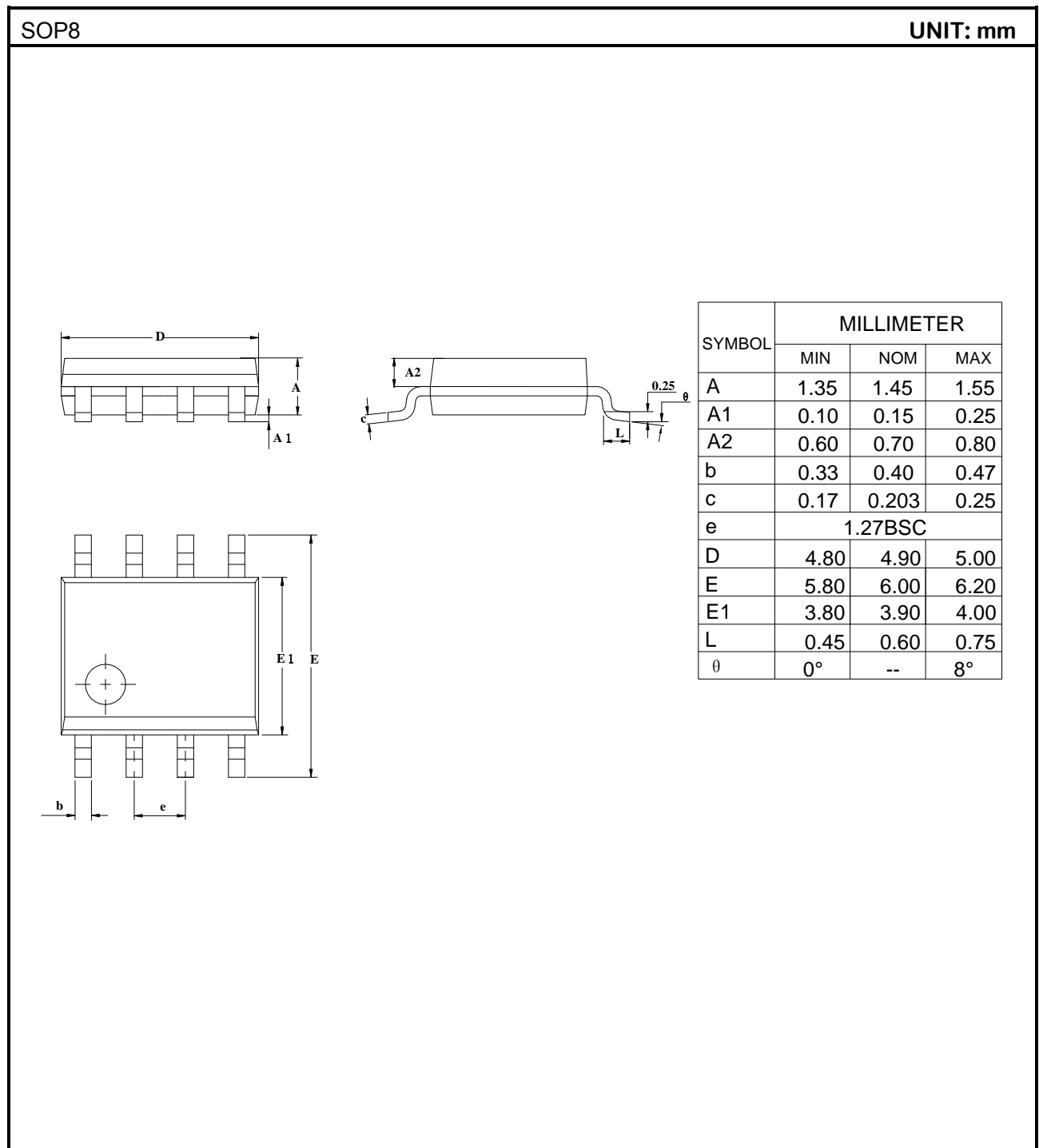

IMPORTANT NOTICE

- Joulwatt Technology Co.,Ltd reserves the right to make modifications, enhancements, improvements, corrections or other changes without further notice to this document and any product described herein.
- Any unauthorized redistribution or copy of this document for any purpose is strictly forbidden.
- Joulwatt Technology Co.,Ltd does not warrant or accept any liability whatsoever in respect of any products purchased through unauthorized sales channel.
- JOULWATT TECHNOLOGY CO.,LTD PROVIDES TECHNICAL AND RELIABILITY DATA (INCLUDING DATASHEETS), DESIGN RESOURCES (INCLUDING REFERENCE DESIGNS), APPLICATION OR OTHER DESIGN ADVICE, SAFETY INFORMATION AND OTHER RESOURCES, AND DISCLAIMS ALL WARRANTIES, EXPRESS AND IMPLIED, INCLUDING WITHOUT LIMITATION ANY IMPLIED WARRANTIES OF MERCHANTABILITY, FITNESS FOR A PARTICULAR PURPOSE OR NON-INFRINGEMENT OF THIRD PARTY INTELLECTUAL PROPERTY RIGHTS.

Copyright © 2023 JoulWatt

All rights are reserved by Joulwatt Technology Co.,Ltd