

Parameters Subject to Change Without Notice

DESCRIPTION

The JW[®]1965AC/ JW1965BC/ JW1965DC/ JW1965EC(JW1965XC series) is a constant current LED driver which applies to single stage Boost power factor corrected LED drivers.

JW1965XC series integrates high voltage power source, and can be supplied by output voltage directly, auxiliary winding and VCC capacitor are not needed.

Patented current sensing and digital compensation technics ensure a unit power factor and high accuracy output current. The critical conduction mode operation reduces the switching losses and increases the efficiency.

JW1965XC series has multi-protection functions which largely enhance the safety and reliability of the system, including LED open protection, freewheeling diode open protection and over-temperature protection.

Company's Logo is Protected, "JW" and "JOULWATT" are Registered

Trademarks of JoulWatt technology Inc.

FEATURES

- No auxiliary winding and VCC capacitor
- Supplied from output voltage directly
- High current accuracy of line and load regulation
- Internal compensation PFC technics
- Critical conduction mode
- High efficiency over wide operating range
- LED open protection
- Freewheeling diode open protection
- Over-temperature protection
- SOP7 package

APPLICATIONS

- Non-isolation Offline LED driver

TYPICAL APPLICATION

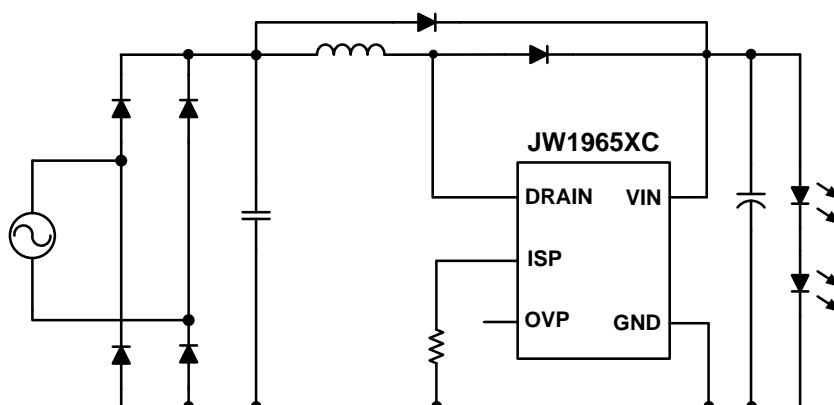

ABSOLUTE MAXIMUM RATING¹⁾

VIN Voltage.....	700V
ISP, OVP Voltage.....	6V
Junction Temperature ^{2) 3)}	150°C
Lead Temperature.....	260°C
Storage Temperature.....	-65°C to +150°C

RECOMMENDED OPERATING CONDITIONS

VIN Voltage.....	30V to 500V
Operating Junction Temperature (T _J)	-40°C to 125°C

THERMAL PERFORMANCE⁴⁾

θ_{JA} θ_{JC}

SOP7.....	96.....45°C/W
-----------	---------------

Note:

- 1) Exceeding these ratings may damage the device. These stress ratings do not imply function operation of the device at any other conditions beyond those indicated under RECOMMENDED OPERATING CONDITIONS.
- 2) The JW1965XC series includes thermal protection that is intended to protect the device in overload conditions. Continuous operation over the specified absolute maximum operating junction temperature may damage the device.
- 3) The device is not guaranteed to function outside of its operating conditions.
- 4) Measured on JESD51-7, 4-layer PCB.

ELECTRICAL CHARACTERISTICS

<i>T_A=25 °C, unless otherwise stated.</i>						
Item	Symbol	Condition	Min.	Typ.	Max.	Units
VIN Start-Up Voltage	V _{IN_ST}			30	35	V
VIN Quiescent Current	I _{INQ}	GATE floating		225	282	μA
ISP Sample Reference	V _{REF}		96	100	104	mV
Minimum On Time of MOSFET	T _{ON_MIN}			0.8		μS
Maximum On Time of MOSFET	T _{ON_MAX}		27	36	45	μS
Minimum Off Time of MOSFET ⁵⁾	T _{OFF_MIN}			2		μS
Maximum Off Time of MOSFET	T _{OFF_MAX}		142	190	238	μS
Maximum Switch Frequency	f _{MAX}		125	150		KHz
Switching Period of VINL ⁵⁾	T _{VINL}			65		μS
MOS R _{dson} ⁵⁾	JW1965AC	R _{dson}	V _{gs} =10V		5.5	Ω
	JW1965BC/EC				1.8	
	JW1965DC				3	
Breakdown Voltage	JW1965AC/DC/EC	BV		500		V
	JW1965BC			600		
ISP Over Voltage Protection Threshold	V _{ISP_MAX}		1.12	1.2	1.28	V
OVP Pin Current	I _{OVP}		3.4	4.6	5.8	μA
Vo Over Voltage Protection Threshold	V _{O_OVP1}	V _{OVP} =2V	246	260	276	V
	V _{O_OVP2}	V _{OVP} =4.8V	487	515	542	V
	V _{O_OVP3}	V _{OVP} =0V	441	468	492	V
Thermal Protection Threshold ⁵⁾	T _{OTP}			150		°C

5) Guaranteed by design

PIN DESCRIPTION

Pin No.	Name	Description
1	GND	Chip ground.
2	OVP	Set OVP threshold.
3	NC	No Connection.
4	VIN	High voltage input.
5,6	DRAIN	Drain of the MOSFET.
7	ISP	Current sense.

BLOCK DIAGRAM

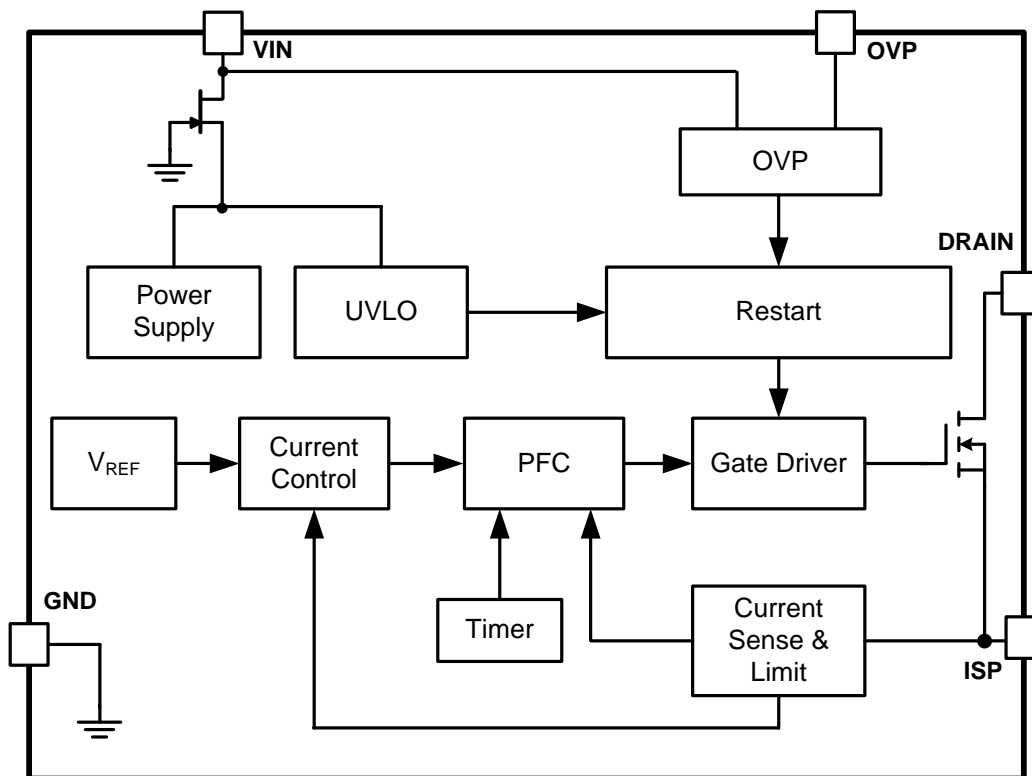

FUNCTIONAL DESCRIPTION

The JW1965XC series is a constant current LED driver which applies to Boost LED system with power factor correction. JW1965XC series can achieve excellent line and load regulation, high efficiency and low system cost with few peripheral components.

Start Up

JW1965XC series is supplied by output voltage directly. When VIN reaches VIN start up voltage (VIN_ST), the chip begins to switch. Once VIN is lower than VIN_ST, JW1965XC series stops switching.

Constant Current Control

The JW1965XC series controls the output current from the information of the sensing resistor voltage. The output LED mean current can be calculated as:

$$I_{LED} = V_{REF} / R_{SNS}$$

Where

VREF – ISP sample reference;

RSNS – The sensing resistor connected between ISP and GND.

Critical Conduction Mode Operation

JW1965XC series works in the Critical conduction mode of the inductor current. When the power MOSFET is turned on, the inductor current begins to increase from zero. The turn on time of the MOSFET can be calculated as:

$$T_{ON} = I_{PK} \times L / V_{IN}$$

Where,

L – Inductance.

IPK – Peak current in one switch cycle.

VIN – Input voltage after rectification and filtering.

When the power MOSFET is turned off, the inductor current begins to decrease. The power

MOSFET turns on again when the inductor current is zero. The turn off time of the MOSFET can be calculated as:

$$T_{OFF} = I_{PK} \times L / (V_{OUT} - V_{IN})$$

Where,

VOUT – Output LED voltage.

And the inductance of the system can be calculated as:

$$L = V_{IN} \times (V_{OUT} - V_{IN}) / (f \times I_{PK} \times V_{OUT})$$

Where, f is the switching frequency of the system.

LED Over Temperature Protection

When the internal temperature of the chip exceeds The thermal Protection Threshold(TOTP), JW1965XC series decreases LED current to help the chip cooling.

LED Open Protection

The OVP threshold (VO_OVP) is set by the OVP pin. When Vo is higher than VO_OVP, LED open protection is triggered and the chip stops switching for 800ms. The following table shows the VO_OVP design guide:

OVP Pin	VO_OVP(V)
Connected with 510 KΩ resistor	VO_OVP1
Not connected	VO_OVP2
Short connected	VO_OVP3

PCB Design

When designing the PCB of the JW1965XC series system, please follow the directions:

1. Make the area of the power loop as small as possible in order to reduce the EMI radiation.
2. The chip should be far away from the heating element, such as the power inductor.

REFERENCE DESIGN

This reference design is suitable for 15W Boost LED driver, using JW1965AC, with high efficiency, excellent line regulation.

Reference :

V_{IN}: 90VAC~264VAC

V_{OUT}: 400V

I_{OUT}: 30mA

PF: >0.9

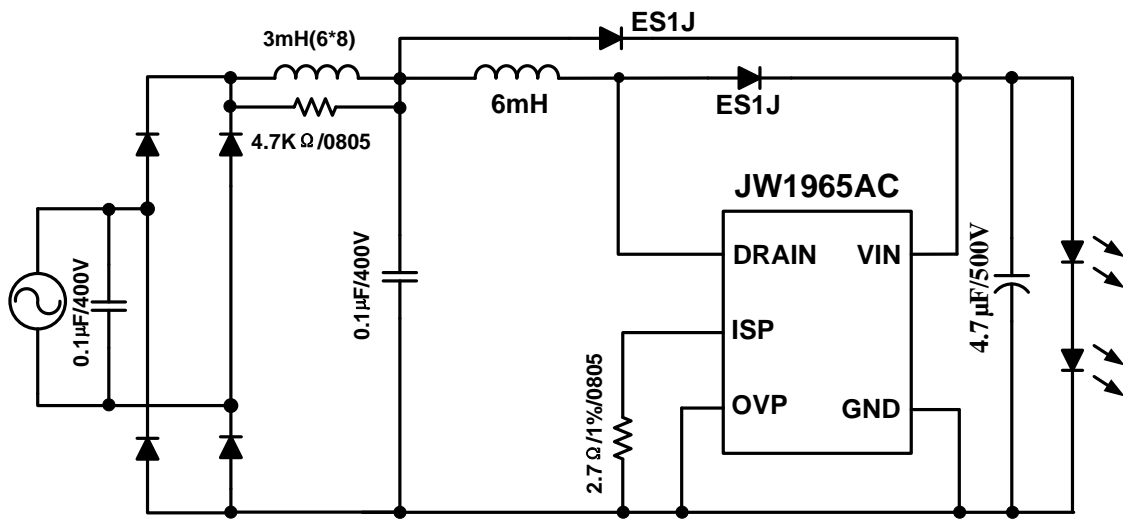

PACKAGE OUTLINE

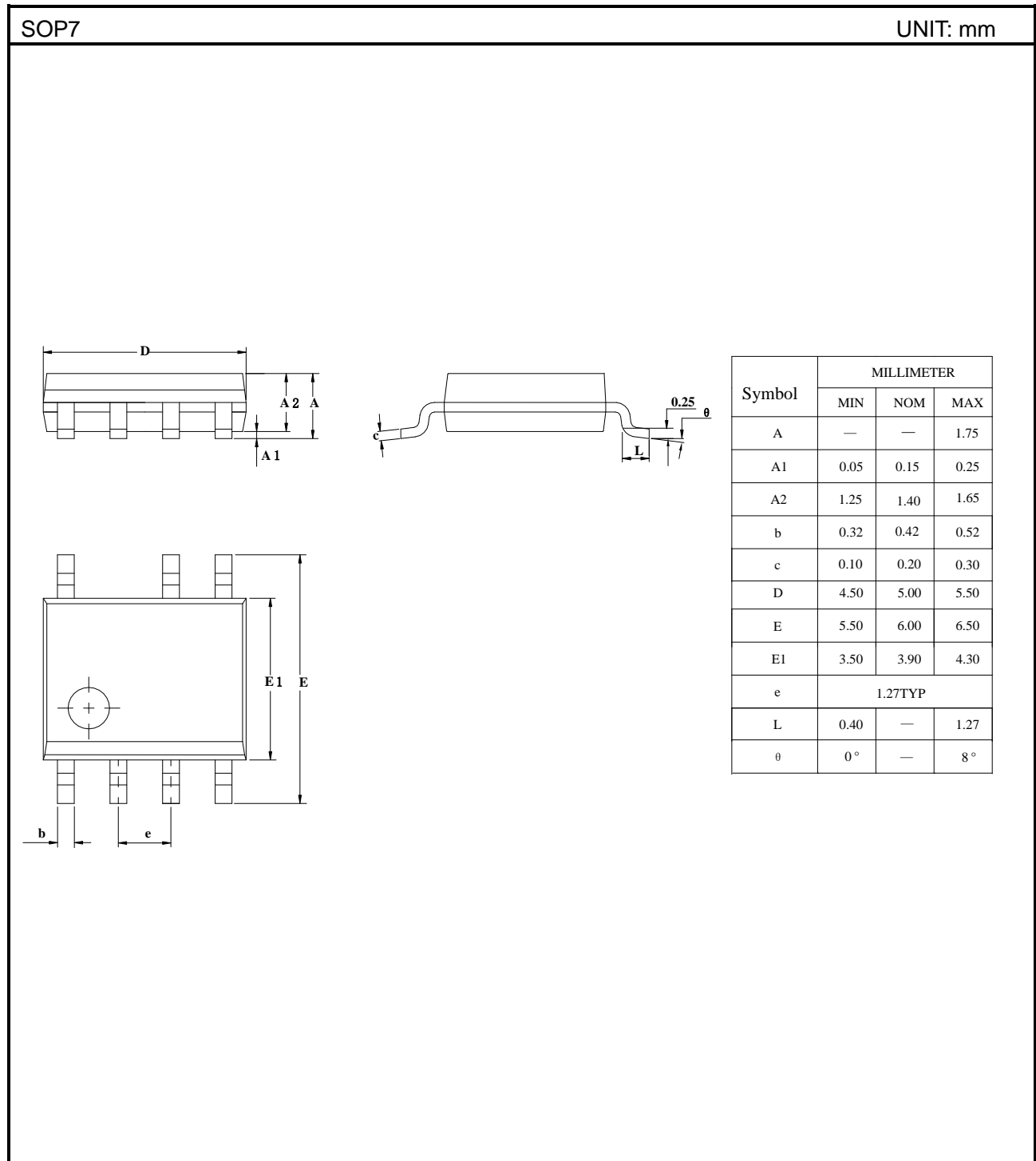

IMPORTANT NOTICE

- Joulwatt Technology Inc. reserves the right to make modifications, enhancements, improvements, corrections or other changes without further notice to this document and any product described herein.
- Any unauthorized redistribution or copy of this document for any purpose is strictly forbidden.
- Joulwatt Technology Inc. does not warrant or accept any liability whatsoever in respect of any products purchased through unauthorized sales channel.

Copyright © 2020 JW1965XC series Incorporated.

All rights are reserved by Joulwatt Technology Inc.