

Parameters Subject to Change Without Notice

DESCRIPTION

JW[®]19818 is a single channel linear LED driver with 500V MOSFET integrated, and the output current is set by the external resistor. Patented current control strategy ensures high output current accuracy while the system is simple with few external components and very low BOM cost.

JW19818 provides over temperature protection. When temperature inside chip exceeds OTP_{CHIP} , JW19818 decreases LED current, which can help chip cooling.

Company's Logo is Protected, "JW" and "JOULWATT" are Registered Trademarks of JoulWatt technology Inc.

FEATURES

- High-accuracy output current.
- Over temperature protection.
- No EMI issues.
- Low BOM cost.
- ESOP-8 packages

APPLICATIONS

- T5/T8 series LED Lighting
- LED Bulb lamp, Floor Lamp

TYPICAL APPLICATION

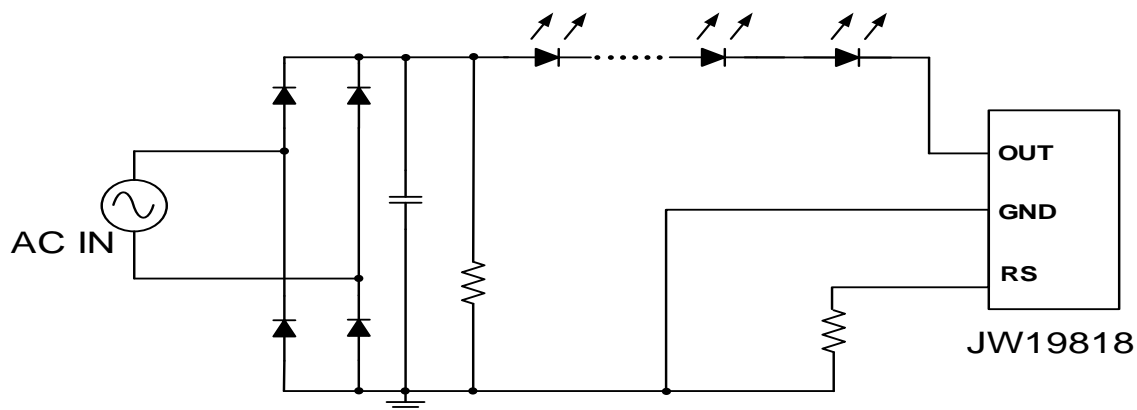

ORDER INFORMATION

DEVICE ¹⁾	PACKAGE	TOP MARKING ²⁾
JW19818ESOP#TRPBF	ESOP-8	JW19818 YW□□□□□

Notes:

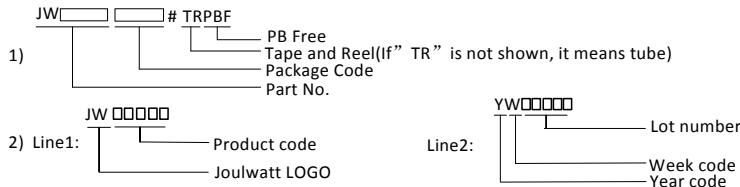

PIN CONFIGURATION

TOP VIEW

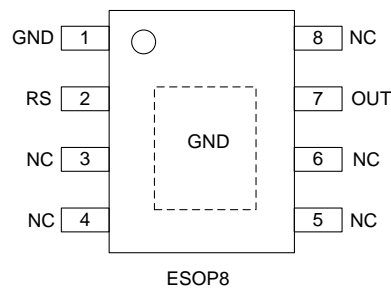

ABSOLUTE MAXIMUM RATING¹⁾

OUT.....	500V
RS.....	-0.3V to 1V
I _{out_max} @ T _a = 25 °C.....	100mA
Junction Temperature ²⁾³⁾	150°C
Lead Temperature	260°C
Storage Temperature	-65°C to +150°C

RECOMMENDED OPERATING CONDITIONS

OUT.....	8.5V~400V
Junction Temperature (T _J)	-40°C to 125°C
I _{out} @220Vac.....	<40mA
I _{out} @110Vac.....	<60mA

THERMAL PERFORMANCE⁴⁾

	θ_{JA}	θ_{JC}
ESOP-8.....	50.....	10°C/W

Note:

- 1) Exceeding these ratings may damage the device.
- 2) The JW19818 guarantees robust performance from -40°C to 150°C junction temperature. The junction temperature range specification is assured by design, characterization and correlation with statistical process controls.
- 3) Continuous operation over the specified absolute maximum operating junction temperature may damage the device.
- 4) Measured on JESD51-7, 4-layer PCB.

ELECTRICAL CHARATERISTICS

T_a = 25 °C, unless otherwise stated.

Item	Symbol	Condition	Min.	Typ.	Max.	Unit.
OUT Minimum Input Voltage	V _{out_min}	I _{OUT} =30mA			7.7	V
OUT Maximum Voltage	V _{out_BV}		450	500		V
Quiescent Current	I _Q	V _{OUT} =40V, V _{RS} =1V		80	100	µA
Reference Voltage	V _{REF}	V _{OUT} =10V	565	600	615	mV
Thermal Protection Threshold ⁵⁾	OTP _{CHIP}			140		°C

Note

5) Guaranteed by design

PIN DESCRIPTION

Pin ESOP-8	Name	Description
1	OUT	The power supply and constant current output
2	GND	Chip ground
3	RS	LED current setup pin

BLOCK DIAGRAM

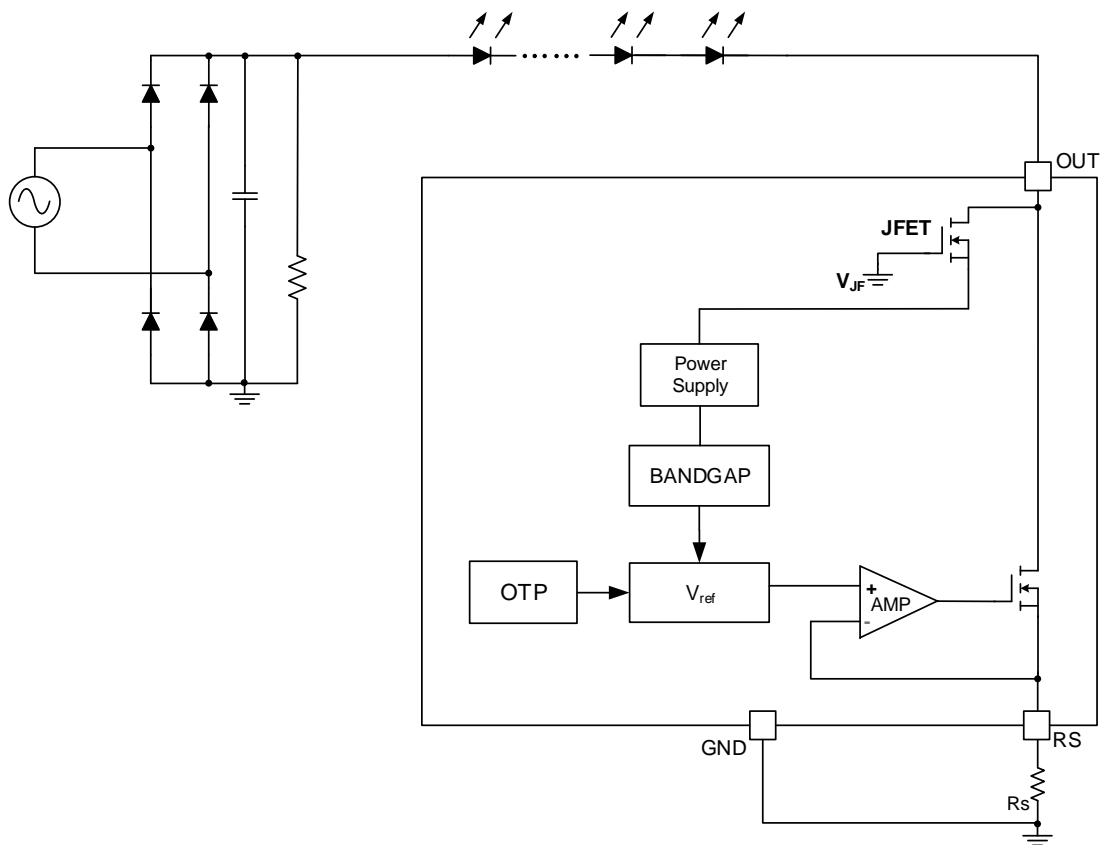

FUNCTIONAL DESCRIPTION

JW19818 is a single channel Linear LED driver for direct line operation.

Theory of Operation

Input power is the rectified voltage from AC line by bridge rectifier. When V_{IN} is higher than the forward voltage of the LEDs, the current of LEDs begins to increase, and I_{LED} reaches its maximum value when the voltage of the OUT pin is higher than V_{out_min} .

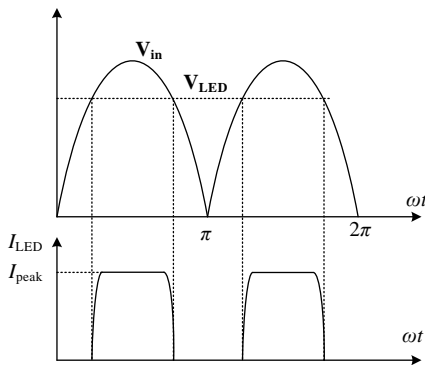

Constant peak current control

JW19818 controls the LED peak current from the information of the current sensing resistor. The output LED peak current can be calculated as:

$$I_{peak} = V_{REF}/R_{cs}$$

Where

V_{REF} is the reference voltage;

R_{cs} is the current sensing resistor connected between RS and chip ground.

Over Temperature Protection

When the junction temperature of JW19818 is higher than OTP_{CHIP} , LED current reduces.

APPLICATION NOTES

1: TRIAC Dimming

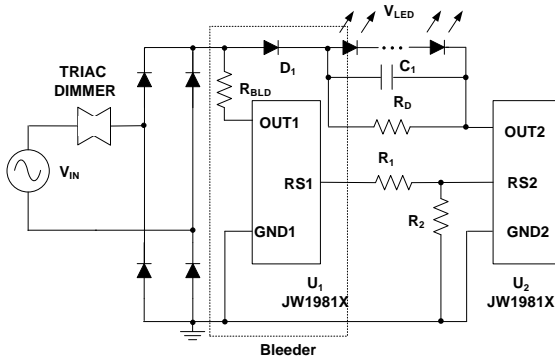

TRIAC Dimming can be achieved if two chips are used. $R_{BLD}=3.3K\Omega$ is recommended to decrease the power loss of the U_1 . D_1 is not essential if C_1 is not connected. R_2 is used to set the LED current (I_{LED}). If the instantaneous input voltage is lower than the LEDs' VF (V_{LED}) when the TRIAC is on, the approximate value of I_{LED} is:

$$I_{LED} \approx V_{REF} \times \frac{\pi - 2 \arcsin \frac{V_{LED}}{\sqrt{2}V_{IN}}}{\pi \times R_2}$$

Where

V_{IN} is the RMS value of the input voltage.

The hold current for the TRIAC dimmer is:

$$I_H = \frac{V_{REF}}{R_1 + R_2}$$

Usually $I_H=25mA$ can ensure the normal operation of most TRIAC dimmers. For example, if $I_{LED}=35mA$, $V_{IN}=120Vac$ and $V_{LED}=123V$, then:

$$R_1=15\Omega, \quad R_2=8.2\Omega$$

2: PCB Design Guideline

The distance between high voltage wire and low voltage wire (including the R_s pin and its peripheral components) should be more than 1mm/200V.

REFERENCE DESIGN

This reference design is suitable for 5W non-isolated LED driver, using JW19818, with few external components.

Reference 1:

V_{IN} : 207VAC~253VAC

V_{OUT} : 250V

I_{OUT} : 25mA

PF: >0.7

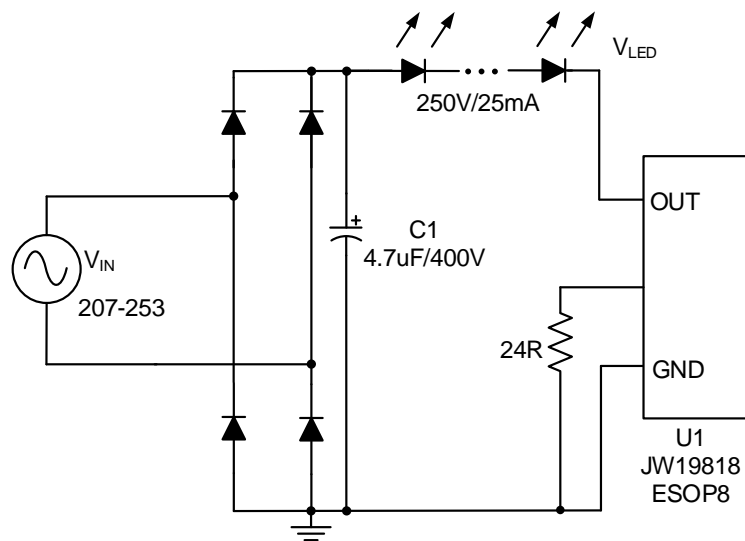

PACKAGE OUTLINE

ESOP-8

UNIT: mm

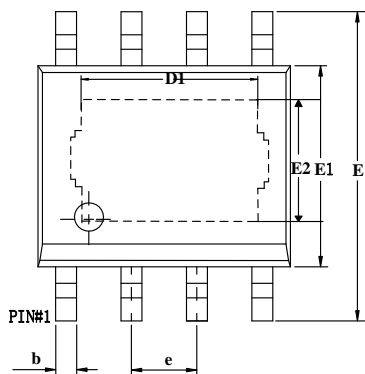
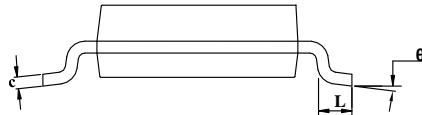
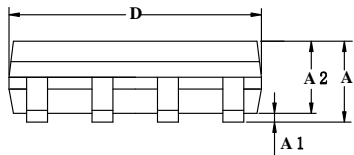

Symbol	MILLIMETER		
	MIN	NOM	MAX
A	1.30	—	1.70
A1	0.00	—	0.10
A2	1.35	—	1.60
b	0.33	—	0.51
c	0.17	—	0.25
D	4.70	—	5.10
E	5.80	6.00	6.20
E1	3.75	3.90	4.15
D1	3.05	—	3.40
E2	2.16	—	2.50
e	1.27BSC		
L	0.40	—	1.27
theta	0°	—	8°

IMPORTANT NOTICE

- Joulwatt Technology Inc. reserves the right to make modifications, enhancements, improvements, corrections or other changes without further notice to this document and any product described herein.
- Any unauthorized redistribution or copy of this document for any purpose is strictly forbidden.
- Joulwatt Technology Inc. does not warrant or accept any liability whatsoever in respect of any products purchased through unauthorized sales channel.

Copyright © 2019 JW19818 Incorporated.

All rights are reserved by Joulwatt Technology Inc.