

2SK1159, 2SK1160

Silicon N Channel MOS FET

REJ03G0911-0200
(Previous: ADE-208-1249)
Rev.2.00
Sep 07, 2005

Application

High speed power switching

Features

- Low on-resistance
- High speed switching
- Low drive current
- No secondary breakdown
- Suitable for switching regulator, DC-DC converter and motor driver

Outline

RENESAS Package code: PRSS0004AC-A
(Package name: TO-220AB)

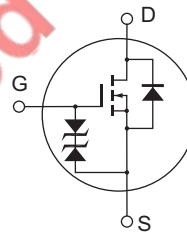

1. Gate
2. Drain
(Flange)
3. Source

Absolute Maximum Ratings

(Ta = 25°C)

Item	Symbol	Ratings	Unit
Drain to source voltage	2SK1159	450	V
	2SK1160	500	
Gate to source voltage	V _{GSS}	±30	V
Drain current	I _D	8	A
Drain peak current	I _{D(pulse)} * ¹	32	A
Body to drain diode reverse drain current	I _{DR}	8	A
Channel dissipation	P _{ch} * ²	60	W
Channel temperature	T _{ch}	150	°C
Storage temperature	T _{stg}	-55 to +150	°C

Notes: 1. PW ≤ 10 μs, duty cycle ≤ 1%

2. Value at T_C = 25°C

Electrical Characteristics

(Ta = 25°C)

Item	Symbol	Min	Typ	Max	Unit	Test conditions
Drain to source breakdown voltage	2SK1159	450	—	—	V	I _D = 10 mA, V _{GS} = 0
	2SK1160	500				
Gate to source breakdown voltage	V _{(BR)GSS}	±30	—	—	V	I _G = ±100 μA, V _{DS} = 0
Gate to source leak current	I _{GSS}	—	—	±10	μA	V _{GS} = ±25 V, V _{DS} = 0
Zero gate voltage drain current	2SK1159	—	—	250	μA	V _{DS} = 360 V, V _{GS} = 0
	2SK1160					V _{DS} = 400 V, V _{GS} = 0
Gate to source cutoff voltage	V _{GS(off)}	2.0	—	3.0	V	I _D = 1 mA, V _{DS} = 10 V
Static drain to source on state resistance	2SK1159	—	0.55	0.7	Ω	I _D = 4 A, V _{GS} = 10 V * ³
	2SK1160	—	0.60	0.8		
Forward transfer admittance	y _{fs}	4.5	7.5	—	S	I _D = 4 A, V _{DS} = 10 V * ³
Input capacitance	C _{iss}	—	1150	—	pF	V _{DS} = 10 V, V _{GS} = 0, f = 1 MHz
Output capacitance	C _{oss}	—	340	—	pF	
Reverse transfer capacitance	C _{rss}	—	55	—	pF	
Turn-on delay time	t _{d(on)}	—	17	—	ns	
Rise time	t _r	—	55	—	ns	I _D = 4 A, V _{GS} = 10 V, R _L = 7.5 Ω
Turn-off delay time	t _{d(off)}	—	100	—	ns	
Fall time	t _f	—	45	—	ns	
Body to drain diode forward voltage	V _{DF}	—	0.9	—	V	I _F = 8 A, V _{GS} = 0
Body to drain diode forward voltage	t _{rr}	—	350	—	ns	I _F = 8 A, V _{GS} = 0, di _F /dt = 100 A/μs

Note: 3. Pulse test

Main Characteristics

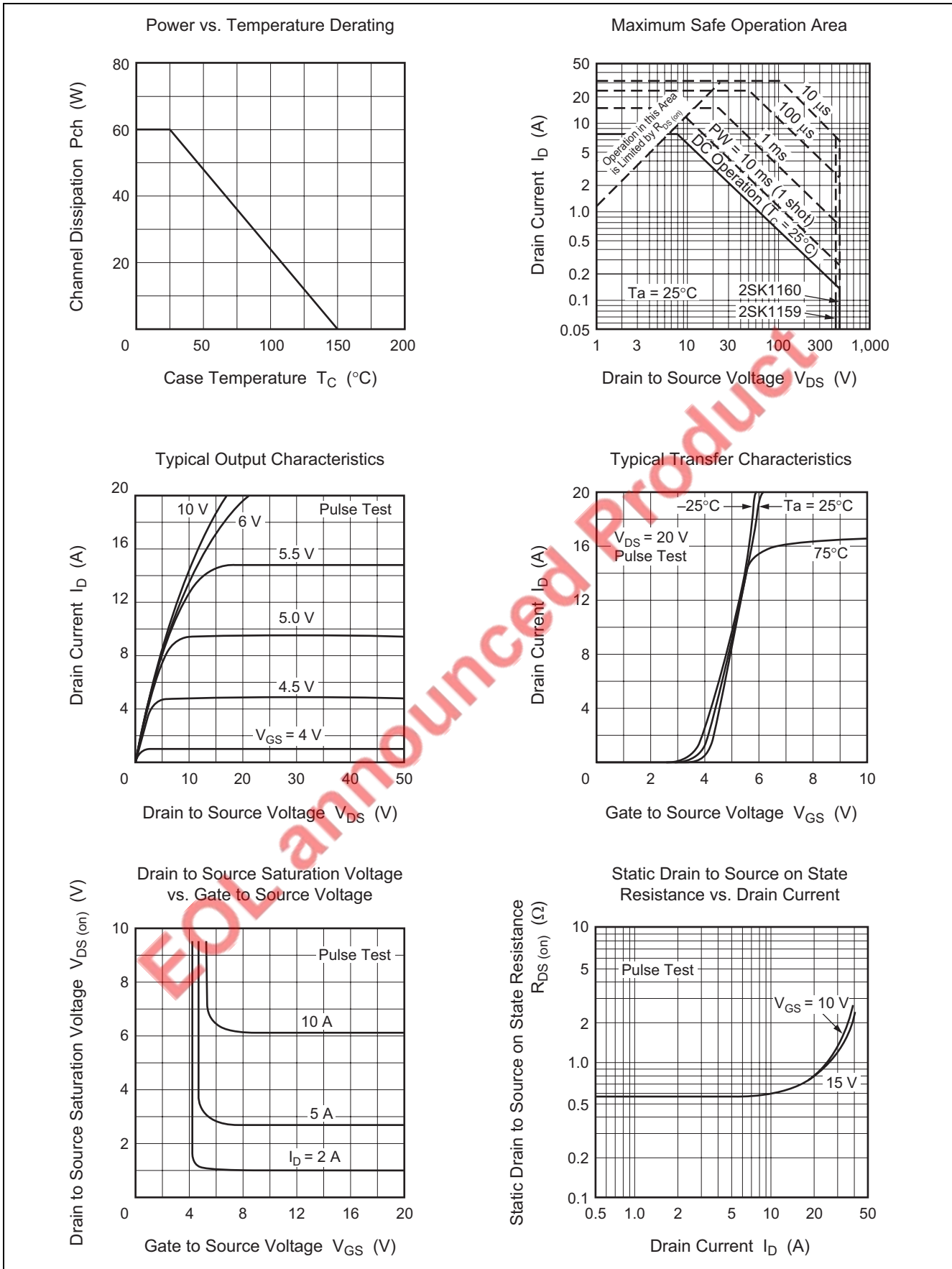

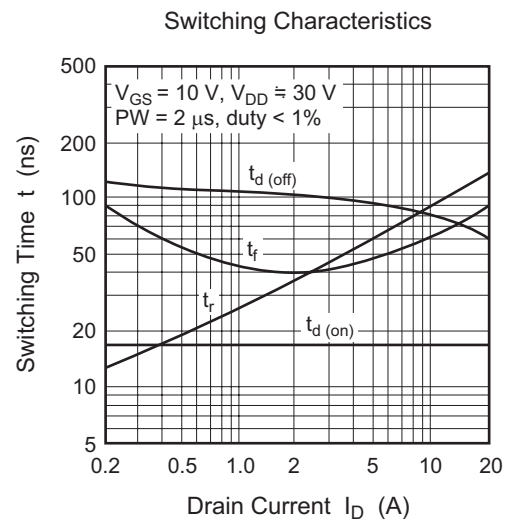
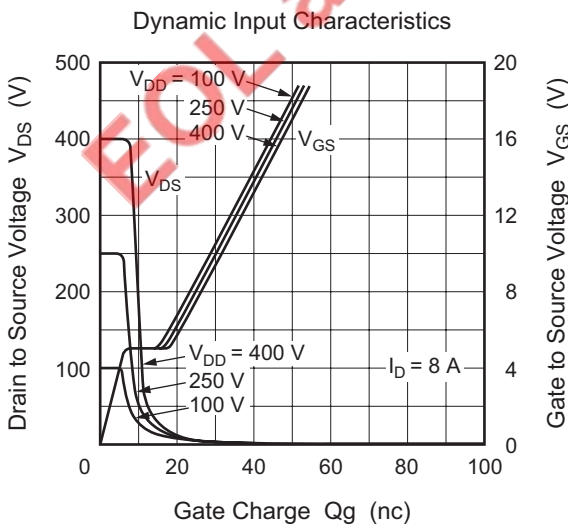
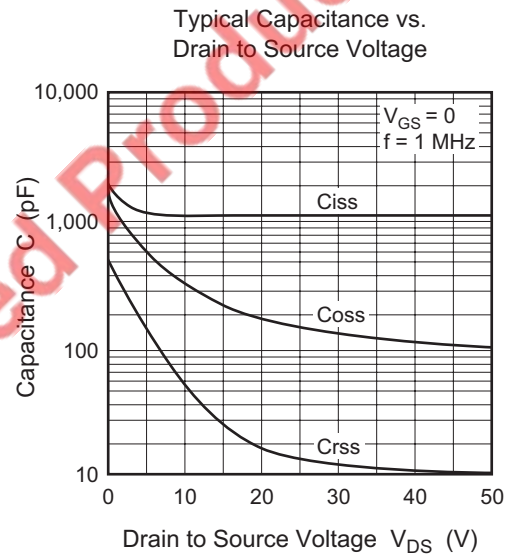
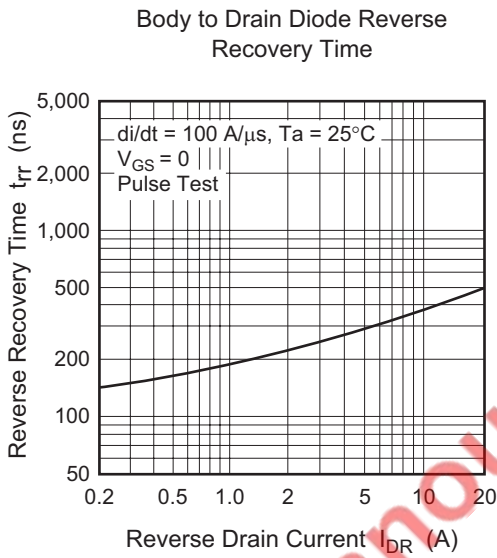
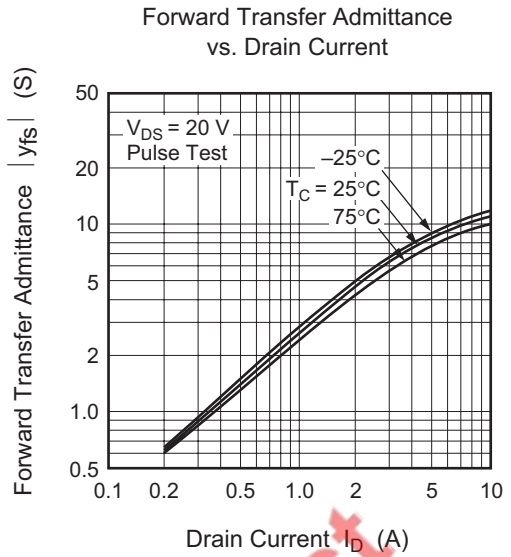
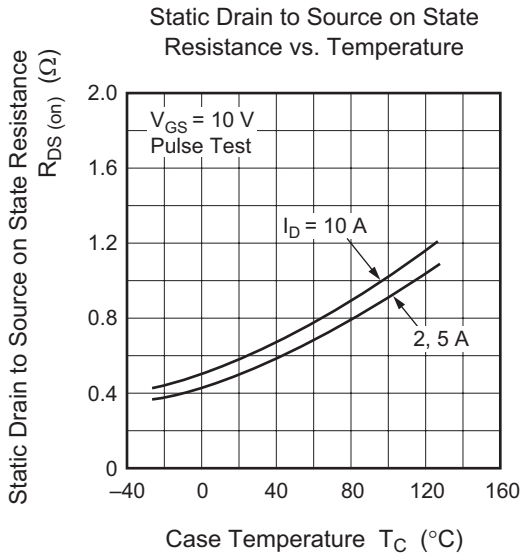

Reverse Drain Current vs. Source to Drain Voltage

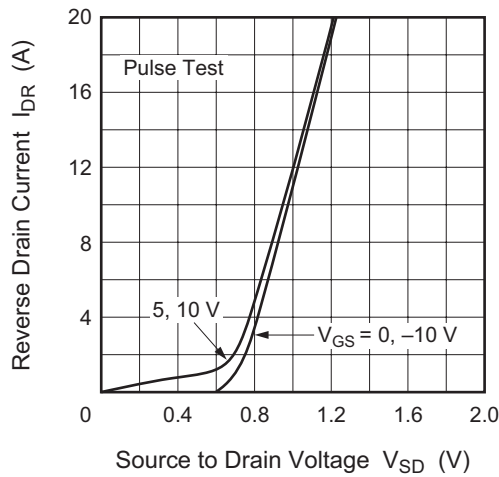

Normalized Transient Thermal Impedance vs. Pulse Width

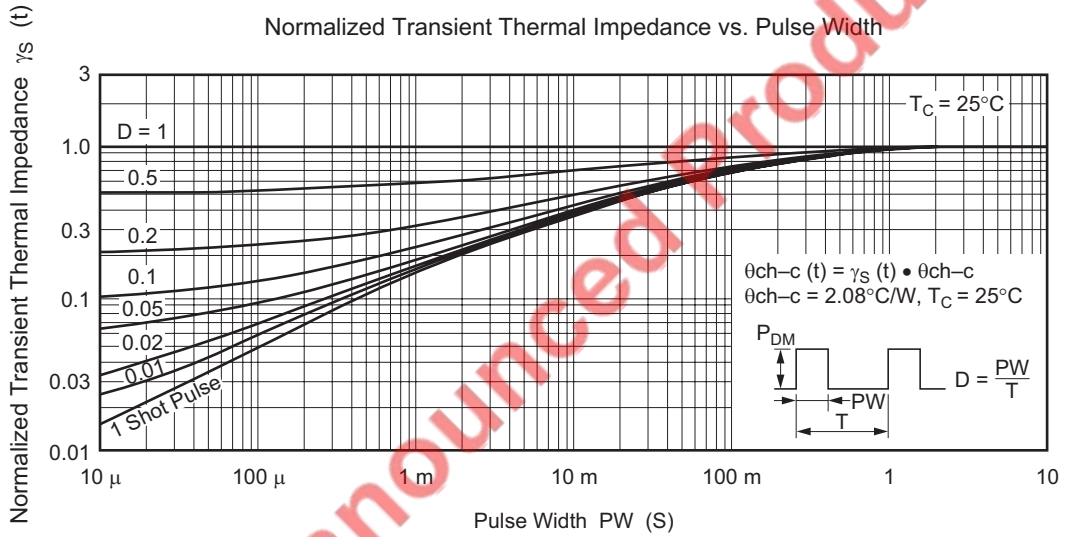

Switching Time Test Circuit

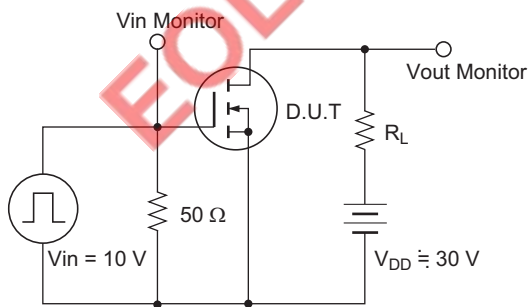

Waveforms

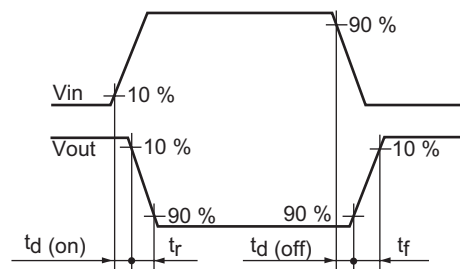

Package Dimensions

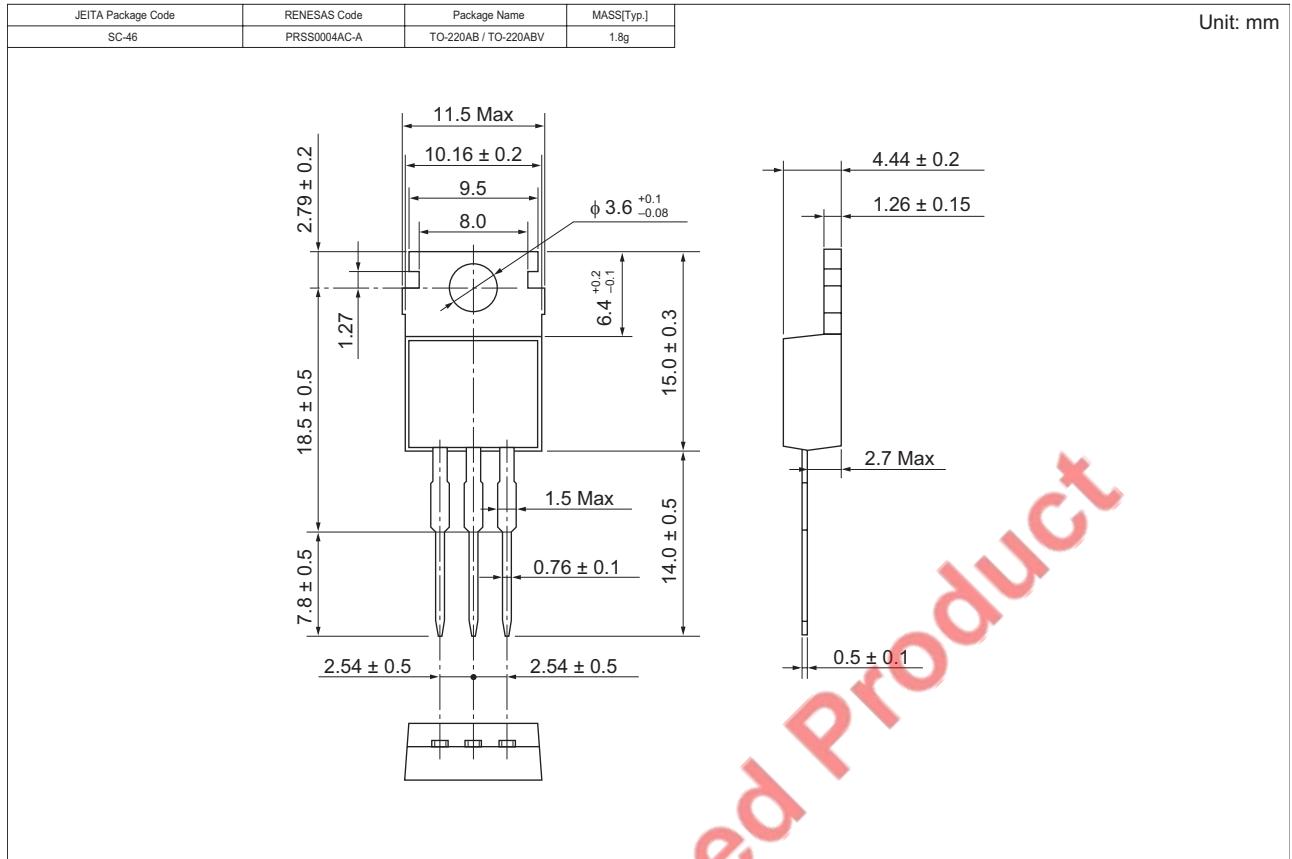

Ordering Information

Part Name	Quantity	Shipping Container
2SK1159-E	500 pcs	Box (Sack)
2SK1160-E	500 pcs	Box (Sack)

Note: For some grades, production may be terminated. Please contact the Renesas sales office to check the state of production before ordering the product.