

K1603TE Series

14 DIP, 5.0 Volt, CMOS/TTL, TCXO



- Former **Champion TECHNOLOGIES, INC.** Product
- Clocking "Sync" to NTSC Video Standards, Reference Signal, Signal Tracking
- Stratum 3 Compliant

Ordering Information

	K1603TE	00.0000
Product Series	_____	_____
Frequency (customer specified)	_____	_____

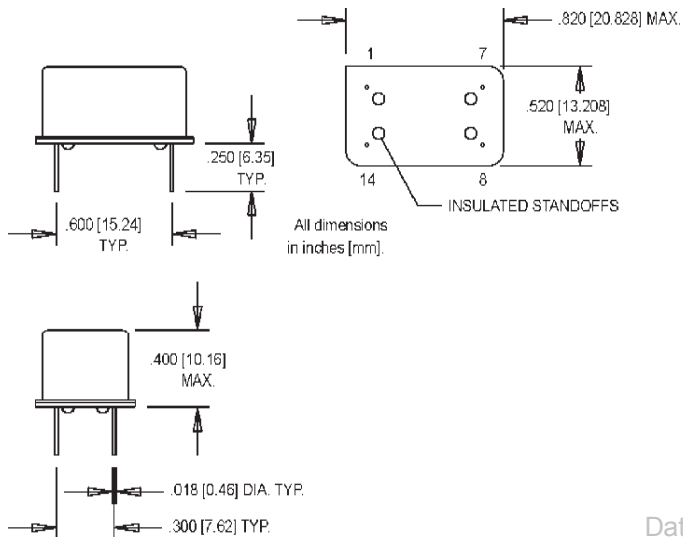

Pin Connections

PIN	FUNCTION
1	Tristate
7	Ground/Case Gnd
8	Output
14	+Vdd

DataSheet4U.com

Electrical Specifications	PARAMETER	Symbol	Min.	Typ.	Max.	Units	Condition/Notes	
	Frequency Range	F	2		30	MHz		
	Operating Temperature	T _A	-40		+85	°C		
	Storage Temperature	T _s	-40		+85	°C		
	Frequency Stability	ΔF/F			±4.6	ppm		
	Aging (10 Year)		-2		+2	ppm		
	Input Voltage	V _{dd}	4.75	5.0	5.25	V		
	Input Current	I _{dd}			20	mA		
	Output Type						HCMOS/TTL	
	Load		5 TTL or 15 pF HCMOS				See Note 1	
	Symmetry (Duty Cycle)						See Note 2	
	<14 MHz		45		55	%		
	≥14 MHz		40		60	%		
	Logic "1" Level	V _{oh}	4.5			V		
	Logic "0" Level	V _{ol}			0.5	V		
	Rise Time	T _r		3.5	9.0	ns		
	Fall Time	T _f		2.0	8.0	ns		
	Tristate Function		Input Logic "1" or N/C: output active Input Logic "0": output disables to high-Z					
	Start up Time				10	ms		
	Phase Noise (Typical)	10 Hz	100 Hz	1 kHz	10 kHz	100 kHz	Offset from carrier	
@ 20 MHz	-80	-108	-125	-132	-155	dBc/Hz		

- TTL load - see load circuit diagram #1 on page 115. HCMOS load - see load circuit diagram #2 on page 115.
- Symmetry is measured at 1.4 V with TTL load, and at 50% V_{dd} with HCMOS load.