



**K350QVG-V2-F
(ATP350G01)**

Product

Standard LCD Module
320 x RGB x 240 Dots
3.5" 262K colors TFT display
Wide temperature
With white LED backlight
With Touch Panel



CONTENTS

	<u>Page No.</u>
1. DOCUMENT REVISION HISTORY	3
2. GENERAL DESCRIPTION	4
3. MECHANICAL SPECIFICATIONS	4
4. INTERFACE SIGNALS	6
5. ABSOLUTE MAXIMUM RATINGS	7
6. ELECTRICAL SPECIFICATIONS	7
7. OPTICAL CHARACTERISTICS	8
8. TIMING CHARACTERISTICS	10
9. RELIABILITY TEST ITEM	10
10. SUGGESTIONS FOR USING LCD MODULES	10
11. INSPECTION STANDARD	13
12. PACKING(REFERENCE ONLY)	19



1. Document revision history :

DOCUMENT REVISION	DATE	DESCRIPTION	PREPARED BY	APPROVED BY
01	2008.04.28	First Release.	MF Zou	
02	2010.06.30	Revised typing error	MF Zou	
03	2010.07.15	Update packing reference	MF Zou	



2. General Description

- 3.5”(diagonal), 320 x RGB x 240 dots, 262K colors, Transmissive, TFT LCD module.
- Viewing Direction: 12 o’clock.
- Driving IC: SSD2119 or equivalent TFT controller/driver.
- 18-bits data bus (parallel RGB interface/8080 parallel system interface).
- With Touch Panel.
- With internal voltage booster.
- Logic voltage: 3.3V (typ.).

3. Mechanical Specifications

The mechanical detail is shown in Fig. 1 and summarized in Table 1 below.

Table 1

Parameter	Specifications	Unit	
Outline dimensions	76.9(W) x 63.9(H) x 4.4(D) (Exclude FPC, cables of backlight)	mm	
Color TFT 320xRGBx240	View area	72.88(W) x 55.36(H)	mm
	TP view area	71.58 (W) x 54.2(H)	mm
	LCD active area	70.08(W) x 52.56(H)	mm
	Display format	320 x RGB x 240	dots
	Color configuration	RGB stripes	-
	Dot size	0.219(RGB)(W) x 0.219(H)	mm
Weight	~40	grams	

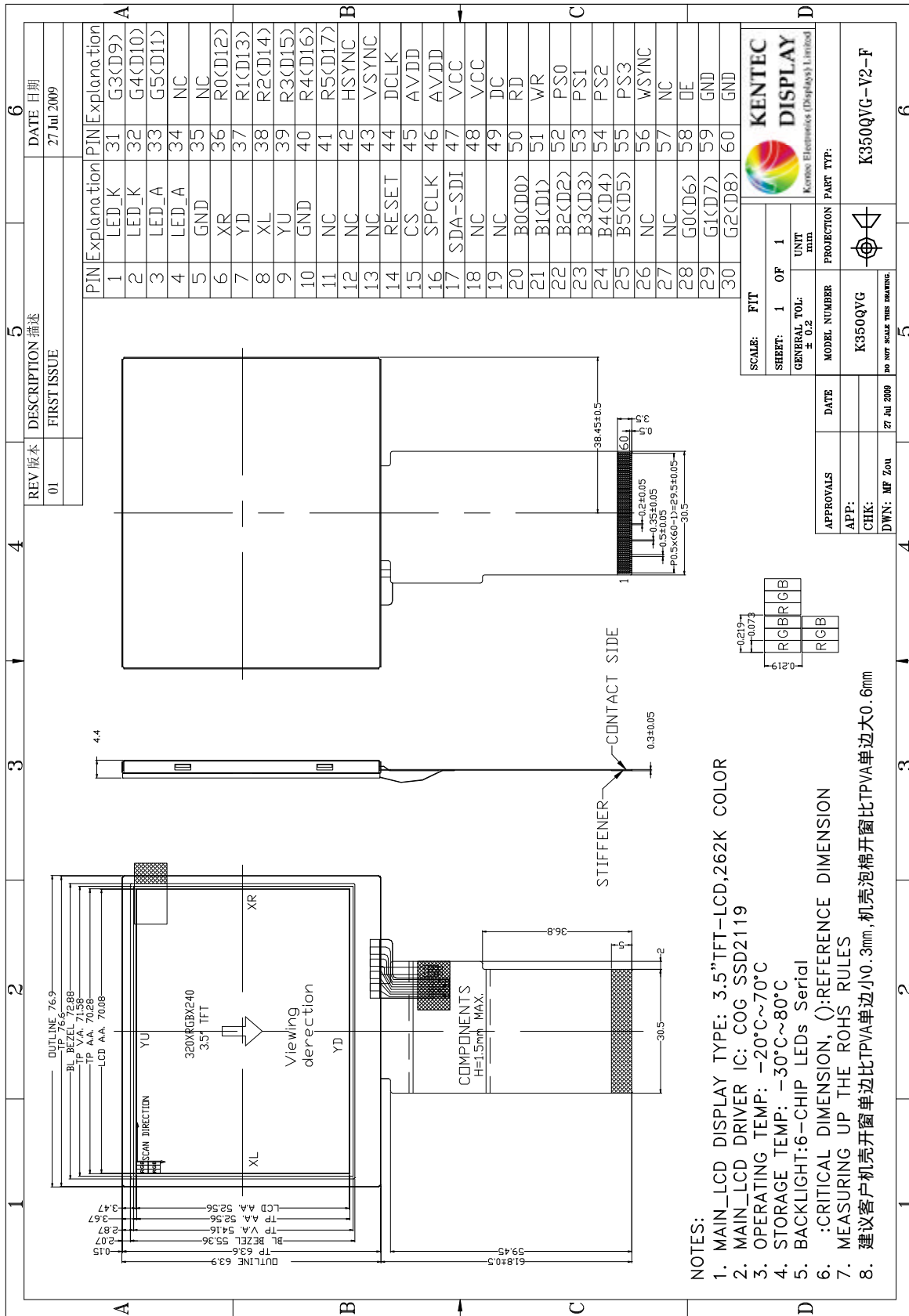

Figure 1: Outline Drawing



4. Interface signals

Table 2: Pin assignment

Pin No.	Symbol	Description																																																		
1-2	LED_K	Power supply for LED backlight																																																		
3-4	LED_A																																																			
5	GND	Power supply (system ground)																																																		
6	XR	Terminal of touch panel.																																																		
7	YD																																																			
8	XL																																																			
9	YU																																																			
10	GND	Power supply (system ground)																																																		
11-13	NC	No connection																																																		
14	RESET	System reset pin																																																		
15	CS	Chip select pin																																																		
16	SPCLK	Clock pin of serial interface																																																		
17	SDA-SDI	Data pin of serial interface																																																		
18-19	NC	No connection																																																		
20-25	B[0-5]	Blue data 6-bit/18bit bi-directional (D0-D5)																																																		
26-27	NC	No connection																																																		
28-33	G[0-5]	Green data 6-bit/18bit bi-directional (D6-D11)																																																		
34-35	NC	No connection																																																		
36-41	R[0-5]	Red data 6-bit/18bit bi-directional (D12-D17)																																																		
42	HSYNC	Line synchronization signal input																																																		
43	VSYNC	Frame /Ram synchronization signal input																																																		
44	DCLK	Dot clock signal																																																		
45-46	AVDD	Supply voltage for lcd driving																																																		
47-48	VCC	Supply voltage for logic																																																		
49	DC	Parallel Interface																																																		
50	RD	I80 system: Serves as a read signal and reads data at the low level.																																																		
51	WR	I80 system: Serves as a write signal and writes data at the rising edge.																																																		
52-55	PS[0:3]	Interface selection pin																																																		
		<table border="1"> <thead> <tr> <th>PS3</th> <th>PS2</th> <th>PS1</th> <th>PS0</th> <th>Interface mode</th> </tr> </thead> <tbody> <tr> <td>0</td> <td>0</td> <td>1</td> <td>0</td> <td>16-bit 8080 parallel interface, D[17:10]&D[8:1]</td> </tr> <tr> <td>0</td> <td>0</td> <td>1</td> <td>1</td> <td>8-bit 8080 parallel interface, D[8:1]</td> </tr> <tr> <td>0</td> <td>1</td> <td>0</td> <td>0</td> <td>9-bit RGB(262 colour) + 3-wire SPI, D[8:0]</td> </tr> <tr> <td>0</td> <td>1</td> <td>0</td> <td>1</td> <td>16-bit RGB(262K colour) + 3-wire SPI, D[17:10]&D[8:1]</td> </tr> <tr> <td>0</td> <td>1</td> <td>1</td> <td>0</td> <td>18-bit RGB(262K colour) + 3-wire SPI, D[17:0]</td> </tr> <tr> <td>0</td> <td>1</td> <td>1</td> <td>1</td> <td>6-bit RGB(262K colour) + 3-wire SPI, D[8:3]</td> </tr> <tr> <td>1</td> <td>0</td> <td>1</td> <td>0</td> <td>18-bit 8080 parallel interface, D[17:0]</td> </tr> <tr> <td>1</td> <td>0</td> <td>1</td> <td>1</td> <td>9-bit 8080 parallel interface, D[8:0]</td> </tr> <tr> <td>1</td> <td>1</td> <td>1</td> <td>0</td> <td>3-wire SPI</td> </tr> </tbody> </table>	PS3	PS2	PS1	PS0	Interface mode	0	0	1	0	16-bit 8080 parallel interface, D[17:10]&D[8:1]	0	0	1	1	8-bit 8080 parallel interface, D[8:1]	0	1	0	0	9-bit RGB(262 colour) + 3-wire SPI, D[8:0]	0	1	0	1	16-bit RGB(262K colour) + 3-wire SPI, D[17:10]&D[8:1]	0	1	1	0	18-bit RGB(262K colour) + 3-wire SPI, D[17:0]	0	1	1	1	6-bit RGB(262K colour) + 3-wire SPI, D[8:3]	1	0	1	0	18-bit 8080 parallel interface, D[17:0]	1	0	1	1	9-bit 8080 parallel interface, D[8:0]	1	1	1	0	3-wire SPI
		PS3	PS2	PS1	PS0	Interface mode																																														
		0	0	1	0	16-bit 8080 parallel interface, D[17:10]&D[8:1]																																														
		0	0	1	1	8-bit 8080 parallel interface, D[8:1]																																														
		0	1	0	0	9-bit RGB(262 colour) + 3-wire SPI, D[8:0]																																														
		0	1	0	1	16-bit RGB(262K colour) + 3-wire SPI, D[17:10]&D[8:1]																																														
		0	1	1	0	18-bit RGB(262K colour) + 3-wire SPI, D[17:0]																																														
		0	1	1	1	6-bit RGB(262K colour) + 3-wire SPI, D[8:3]																																														
		1	0	1	0	18-bit 8080 parallel interface, D[17:0]																																														
1	0	1	1	9-bit 8080 parallel interface, D[8:0]																																																
1	1	1	0	3-wire SPI																																																
56	WSYNC	Ram Write Synchronization output																																																		
57	NC	No connection																																																		
58	OE	Display enable pin from controller																																																		
59-60	GND	Power supply (system ground)																																																		



5. Absolute Maximum Ratings

5.1 Electrical Maximum Ratings – for IC Only

Table 3: Electrical Maximum Ratings – for IC

Parameter	Symbol	Min.	Max.	Unit	Note
Supply voltage	VCC	-0.3	+4.0	V	1
Input voltage	AVDD	-0.3	+5.0	V	

Note:

- 1.VCC, GND must be maintained.
- 2.The modules may be destroyed if they are used beyond the absolute maximum ratings.

5.2 Environmental Condition

Table 4

Item	Operating temperature (Topr)		Storage temperature (Tstg) (Note 1)		Remark
	Min.	Max.	Min.	Max.	
Ambient temperature	-20°C	+70°C	-30°C	+80°C	Dry
Humidity (Note 1)	80% max. RH for Ta ≤ 40°C < 50% RH for 40°C < Ta ≤ Maximum operating temperature				No condensation

Note 1: Product cannot sustain at extreme storage conditions for long time.

6. Electrical Specifications

Typical Electrical Characteristics

At Ta = 25 °C, VCC=IOVCC= 3.3V, GND=0V.

Table 5

Parameter	Symbol	Conditions	Min.	Typ.	Max.	Unit
Supply voltage (logic)	VCC-GND		1.4	-	3.6	V
Supply voltage (lcd driving)	AVDD		2.5 or VDDIO	-	3.6	V
Output voltage(LCD)	VGH		9	-	18.0	V
	VGL		-15.0	-	-6	V
	VCOM		-1	-	6	V
Supply current (Logic & LCD)	ICC	VDD=3.3V	-	-	10	mA
Supply voltage of white LED backlight	VLED	Forward current =20 mA	-	19.2	21.6	V
Luminance (on the module surface)		Number of LED dies = 6	230	270	-	cd/m ²



7. Optical Characteristics

Table 7: Optical specifications

Items	Symbol	Condition	Specifications			Unit
			Min.	Typ.	Max.	
Contrast Ratio	CR		150	300	-	-
Response Time	T _R		-	15	30	ms
	T _F		-	35	50	ms
Chromaticity	Red	X _R	0.604	0.624	0.644	-
		Y _R	0.302	0.322	0.342	-
	Green	X _G	0.268	0.288	0.308	-
		Y _G	0.540	0.560	0.580	-
	Blue	X _B	0.127	0.147	0.167	-
		Y _B	0.097	0.117	0.137	-
	White	X _W	-	0.307	-	-
		Y _W	-	0.328	-	-
Viewing angle	Hor.	φ1(3 o'clock)	-	45	-	deg.
		φ2(9 o'clock)	-	45	-	
	Ver.	θ2(12 o'clock)	-	15	-	
		θ1(6 o'clock)	-	35	-	
NTSC ratio				61.5		%

Note

Note 1: Definition of Contrast Ratio (CR):

The contrast ratio can be calculated by the following expression.

$$\text{Contrast Ratio (CR)} = L_{63} / L_0$$

L₆₃: Luminance of gray level 63

L₀: Luminance of gray level 0

$$\text{CR} = \text{CR} (10)$$

CR (X) is corresponding to the Contrast Ratio of the point X at Figure in Note 5.

Note 2: Definition of Response Time (TR, TF):

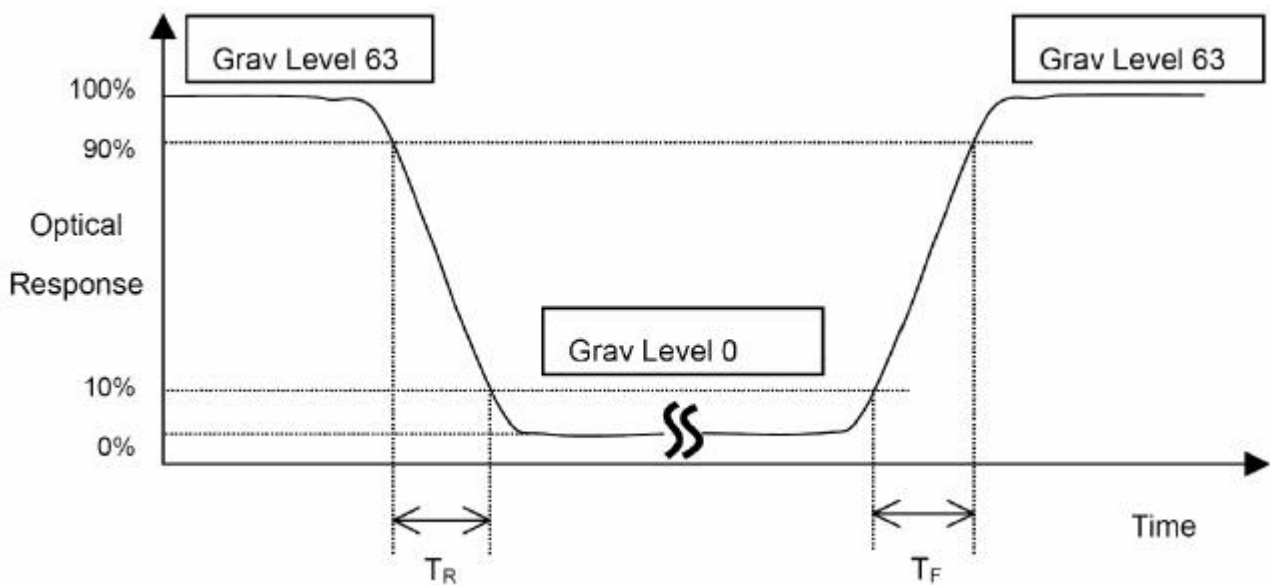

Figure 3



Note 3: Viewing Angle

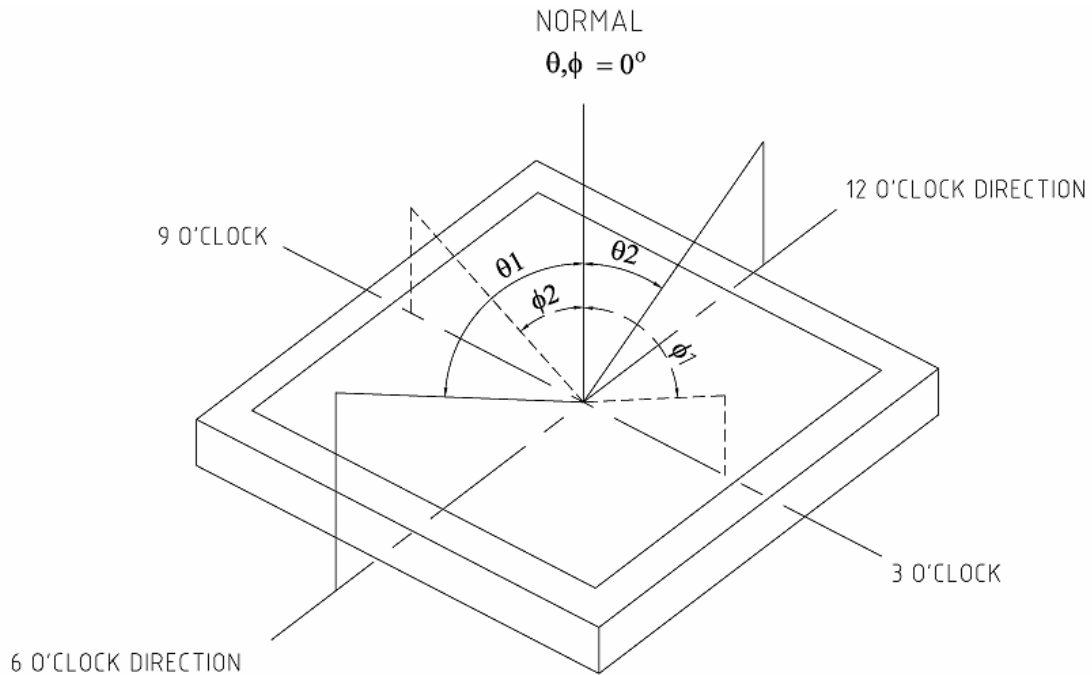

Figure 4

The above “Viewing Angle” is the measuring position with Largest Contrast Ratio; not for good image quality. View Direction for good image quality is 6 O’clock. Module maker can increase the “Viewing Angle” by applying Wide View Film.

Note 4: Measurement Set-Up:

The LCD module should be stabilized at a given temperature for 20 minutes to avoid abrupt temperature change during measuring. In order to stabilize the luminance, the measurement should be executed after lighting Backlight for 20 minutes in a windless room.

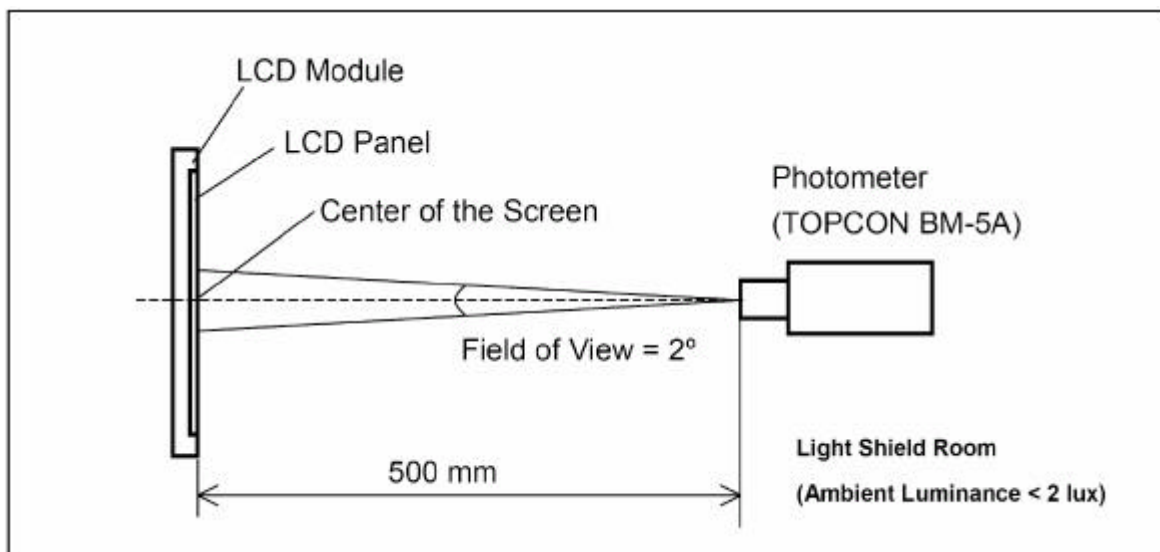

Figure 5



8. AC Characteristics

Please refer SSD2119 datasheet.

9. Reliability Test Item

Test Item	Sample Type	Test Condition	Test result determinant gist
High temperature storage	Normal temperature	70±3 ;96H	the inspection of appearance and function character.
	Wide temperature	80±3 ;96H	
Low temperature storage	Normal temperature	-20±3 ;120H	
	Wide temperature	-30±3 ;120H	
High temperature /humidity storage	Normal temperature	50 ±3 ,90%±3%RH;96H	
	Wide temperature	60 ±3 ,90%±3%RH;96H	
High temperature operation	Normal temperature	60±3 ;96H	no objection of the function character; no fatal objection of the appearance.
	Wide temperature	70±3 ;96H	
Low temperature operation	Normal temperature	0±3 ;96H	
	Wide temperature	-20±3 ;96H	
High temperature /humidity operation	Normal temperature	40 ±3 ,90%±3%RH;96H	
	Wide temperature	50 ±3 ,90%±3%RH;96H	
Temperature Shock	Normal temperature	-20±3 ,30min? 70±3 ,30 min;10cycle	inspect the objections appearance、 function & the whole structure
	Wide temperature	-30±3 ,30min 80±3,30min;10cycle	The inspection of appearance、 function & the whole structure

10. Suggestions for using LCD modules

10.1 Handling of LCM

1. The LCD screen is made of glass. Don't give excessive external shock, or drop from a high place.
2. If the LCD screen is damaged and the liquid crystal leaks out, do not lick and swallow. When the liquid is attach to your hand, skin, cloth etc, wash it off by using soap and water thoroughly and immediately.
3. Don't apply excessive force on the surface of the LCM.
4. If the surface is contaminated ,clean it with soft cloth. If the LCM is severely contaminated , use Isopropyl alcohol/Ethyl alcohol to clean. Other solvents may damage the polarizer . The following solvents is especially prohibited: water , ketone Aromatic solvents etc.
5. Exercise care to minimize corrosion of the electrode. Corrosion of the electrodes is accelerated by



water droplets, moisture condensation or a current flow in a high-humidity environment.

6. Install the LCD Module by using the mounting holes. When mounting the LCD module make sure it is free of twisting, warping and distortion. In particular, do not forcibly pull or bend the I/O cable or the backlight cable.

7. Don't disassemble the LCM.

8. To prevent destruction of the elements by static electricity, be careful to maintain an optimum work environment.

- Be sure to ground the body when handling the LCD modules.
- Tools required for assembling, such as soldering irons, must be properly grounded.
- To reduce the amount of static electricity generated, do not conduct assembling and other work under dry conditions.
- The LCD module is coated with a film to protect the display surface. Exercise care when peeling off this protective film since static electricity may be generated.

9. Do not alter, modify or change the the shape of the tab on the metal frame.

10. Do not make extra holes on the printed circuit board, modify its shape or change the positions of components to be attached.

11. Do not damage or modify the pattern writing on the printed circuit board.

12. Absolutely do not modify the zebra rubber strip (conductive rubber) or heat seal connector

13. Except for soldering the interface, do not make any alterations or modifications with a soldering iron.

14. Do not drop, bend or twist LCM.

10.2 Cautions for installing and assembling if the module has Touch Panel

1. Use a buffer material (Gasket) between the touch panel and Front-case to protect damage and wrong operating. The dimension of the buffer material's edge between the TP V.A. edge is Min. 0.3mm.

2. We recommend to design a case that it can't over the boundary of the active area Max. 0.5mm in order to prevent an operation at outside of the active area which can't guarantee the specified durability,



because operation at the outside of the active area cause serious damage of a transparent.

3. When design case for installing Module, you would consider give a distance about $0.2 \pm 0.15\text{mm}$ between the module edge to case inside.

4. The corners of the product are not chamfered. When positioning and fixing the product on the case, we suggest that you would provide a R part on the corner of the case so as not to apply load on the corner of the transparent module.

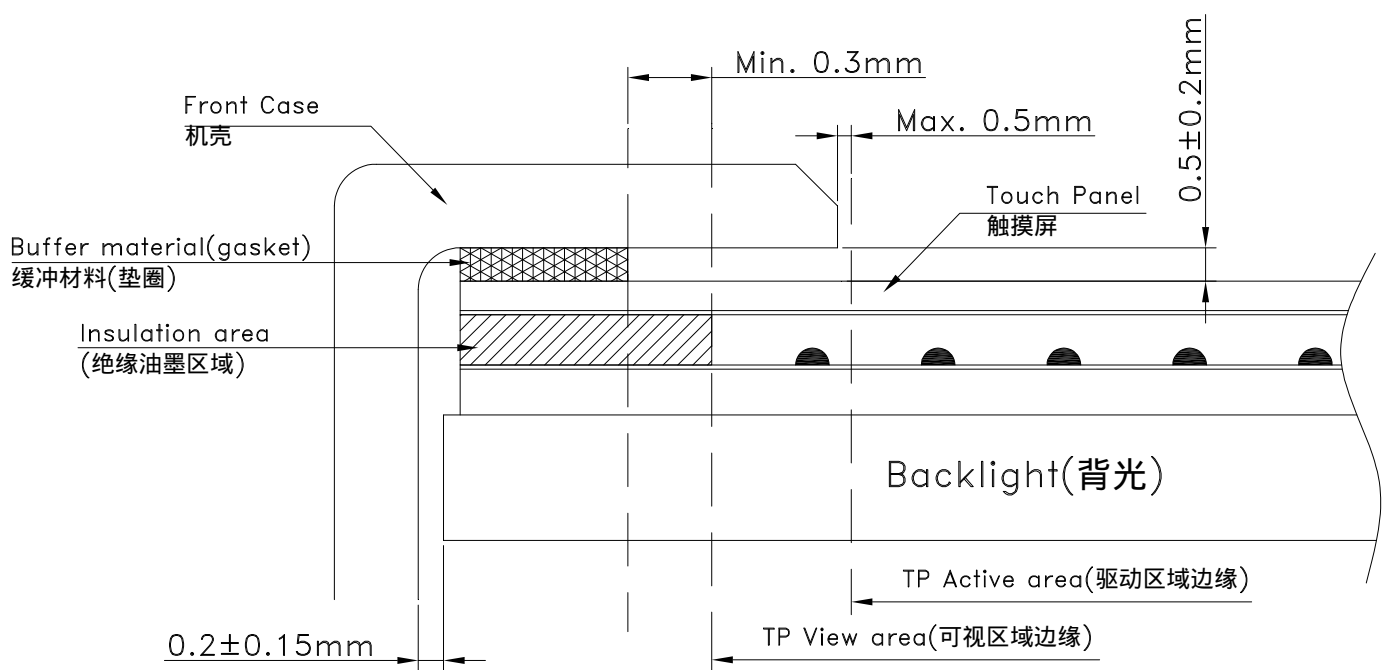

10.3 Storage

1. Store in an ambient temperature of 5 to 45 °C, and in a relative humidity of 40% to 60%. Don't expose to sunlight or fluorescent light.
2. Storage in a clean environment, free from dust, active gas, and solvent.
3. Store in antistatic container.



11. Inspection Standard

This specification is made to be used as the standard acceptance/rejection criteria for Color mobile phone LCM with touch pannel.

11.1 Sample plan and Inspection condition

11.1.1 Sample plan

Sampling plan according to MIL-STD-105E , normal level 2 and based on:

Major defect: AQL 0.65;

Minor defect: AQL 1.5.

11.1.2 Inspection condition

Viewing distance for cosmetic inspection is about 30cm with bare eyes, and under an environment of 20~40W light intensity, all directions for inspecting the sample should be within 45 against perpendicular line.

11.2 Definition of inspection zone in LCD

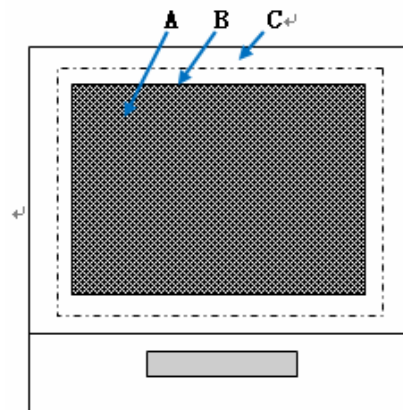

Inspection zones in an LCD

Zone A: character/Digit area;

Zone B: viewing area except Zone A (ZoneA+ZoneB=minimum Viewing area);

Zone C: Outside viewing area (invisible area after assembly in customer's product);

Note: As a general rule, visual defects in Zone C are permissible, when it is no trouble for quality and assembly of customer's product. Defects are classified as major defects and minor defects according to the degree of defectiveness defined herein.

11.3 Major defects and Minor defects

11.3.1 Major defects

A major defect is a defect that is likely to result in failure, or to reduce the usability of the product for its intended purpose.

11.3.1.1 Abnormal operation: modules cannot display normally;



11.3.1.2 Line defect;

11.3.1.3 There is serious distortion or sharp burr on mechanical housing;

11.3.1.4 Glass breakage.

11.3.2 Minor defects:

A minor defect is a defect that is not likely to reduce the usability of the product for its intended purpose.

11.3.2.1 Dot defect:

11.3.2.1.1 Inspection pattern : Full white, full black, red, green and blue screens;

11.3.2.1.2 Criteria :(acceptable);

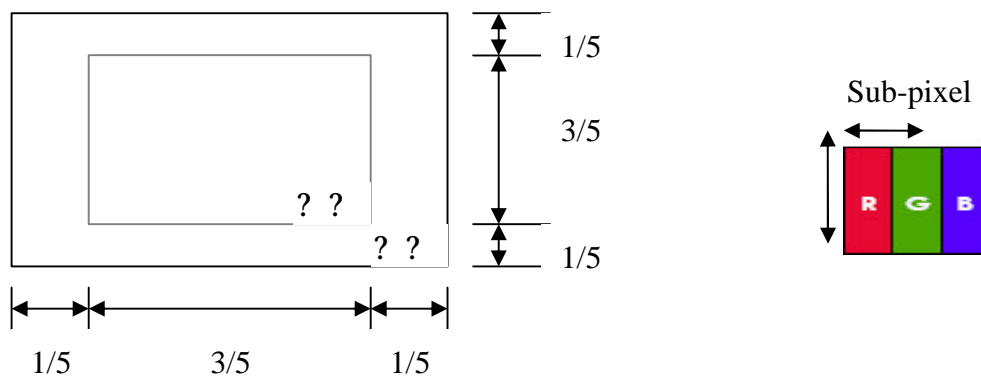

Note: 1. Dot defect is defined as the defective area of the dot area is larger than 50% of the dot area . And the bright dot defect must be visible through 5% ND filter.

2. Except for the allowed numbers of adjacent dots, the distance between dot defects should be more than 3mm apart.

11.3.2.1.3 The definitions of the inner display area and outer display area.

11.4 Inspection standards table:

11.4.1 Major defect

Item No.	Items to be	Inspection Standard	Classification of defects
11.4.1.1	All functional defects	1) No display 2) Display abnormally 3) Missing vertical/horizontal segment 4) Short circuit 5) Back-light no lighting, flickering and abnormal lighting.	Major
11.4.1.2	Missing	Missing component	
11.4.1.3	Outline dimension	Overall outline dimension beyond the drawing is not allowed.	
11.4.1.4	linearity	No more than 1.5%	

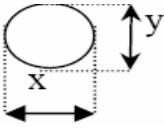

11.4.2 Cosmetic Defect (spot defect)

Item No	Itemsto be	Inspection Standard	Classification of defects																							
11.4.2.1	Clear Spots Black and white Spot defect Pinhole, Foreign Particle, polarizer Dirt	For dark/white spot, sizeF is defined as $F = (x + y) / 2$ 	Minor																							
		<table border="1"> <thead> <tr> <th rowspan="2">Zone Size(mm)</th> <th colspan="3">Acceptable Qty</th> </tr> <tr> <th>A</th> <th>B</th> <th>C</th> </tr> </thead> <tbody> <tr> <td>F=0.1</td> <td colspan="3">Ignore</td> </tr> <tr> <td>0.10< F=0.15</td> <td colspan="3">2</td> </tr> <tr> <td>0.15< F=0.20</td> <td colspan="3">1</td> </tr> <tr> <td>F> 0.20</td> <td colspan="3">0</td> </tr> </tbody> </table>	Zone Size(mm)	Acceptable Qty			A	B	C	F=0.1	Ignore			0.10< F=0.15	2			0.15< F=0.20	1			F> 0.20	0			Minor
		Zone Size(mm)		Acceptable Qty																						
			A	B	C																					
		F=0.1	Ignore																							
0.10< F=0.15	2																									
0.15< F=0.20	1																									
F> 0.20	0																									
<table border="1"> <thead> <tr> <th rowspan="2">Zone Size(mm)</th> <th colspan="3">Acceptable Qty</th> </tr> <tr> <th>A</th> <th>B</th> <th>C</th> </tr> </thead> <tbody> <tr> <td>F=0.1</td> <td colspan="3">Ignore</td> </tr> <tr> <td>0.10< F=0.15</td> <td colspan="3">2</td> </tr> <tr> <td>0.15< F=0.25</td> <td colspan="3">1</td> </tr> <tr> <td>F> 0.25</td> <td colspan="3">0</td> </tr> </tbody> </table>	Zone Size(mm)	Acceptable Qty			A	B	C	F=0.1	Ignore			0.10< F=0.15	2			0.15< F=0.25	1			F> 0.25	0					
Zone Size(mm)		Acceptable Qty																								
	A	B	C																							
F=0.1	Ignore																									
0.10< F=0.15	2																									
0.15< F=0.25	1																									
F> 0.25	0																									
<table border="1"> <thead> <tr> <th rowspan="2">Zone Size(mm)</th> <th colspan="3">Acceptable Qty</th> </tr> <tr> <th>A</th> <th>B</th> <th>C</th> </tr> </thead> <tbody> <tr> <td>F=0.2</td> <td colspan="3">Ignore</td> </tr> <tr> <td>0.20< F=0.4</td> <td colspan="3">2</td> </tr> <tr> <td>0.4< F=0.6</td> <td colspan="3">1</td> </tr> <tr> <td>F> 0.6</td> <td colspan="3">0</td> </tr> </tbody> </table>	Zone Size(mm)	Acceptable Qty			A	B	C	F=0.2	Ignore			0.20< F=0.4	2			0.4< F=0.6	1			F> 0.6	0					
Zone Size(mm)		Acceptable Qty																								
	A	B	C																							
F=0.2	Ignore																									
0.20< F=0.4	2																									
0.4< F=0.6	1																									
F> 0.6	0																									
<table border="1"> <thead> <tr> <th rowspan="2">Zone Size(mm)</th> <th colspan="3">Acceptable Qty</th> </tr> <tr> <th>A</th> <th>B</th> <th>C</th> </tr> </thead> <tbody> <tr> <td>F=0.2</td> <td colspan="3">Ignore</td> </tr> <tr> <td>0.20< F=0.4</td> <td colspan="3">2</td> </tr> <tr> <td>0.4< F=0.6</td> <td colspan="3">1</td> </tr> <tr> <td>F> 0.6</td> <td colspan="3">0</td> </tr> </tbody> </table>	Zone Size(mm)	Acceptable Qty			A	B	C	F=0.2	Ignore			0.20< F=0.4	2			0.4< F=0.6	1			F> 0.6	0					
Zone Size(mm)		Acceptable Qty																								
	A	B	C																							
F=0.2	Ignore																									
0.20< F=0.4	2																									
0.4< F=0.6	1																									
F> 0.6	0																									
11.4.2.2	Clear Spots TP Dirt	<table border="1"> <thead> <tr> <th rowspan="2">Zone Size(mm)</th> <th colspan="3">Acceptable Qty</th> </tr> <tr> <th>A</th> <th>B</th> <th>C</th> </tr> </thead> <tbody> <tr> <td>F=0.1</td> <td colspan="3">Ignore</td> </tr> <tr> <td>0.10< F=0.15</td> <td colspan="3">2</td> </tr> <tr> <td>0.15< F=0.25</td> <td colspan="3">1</td> </tr> <tr> <td>F> 0.25</td> <td colspan="3">0</td> </tr> </tbody> </table>	Zone Size(mm)	Acceptable Qty			A	B	C	F=0.1	Ignore			0.10< F=0.15	2			0.15< F=0.25	1			F> 0.25	0			Minor
Zone Size(mm)	Acceptable Qty																									
	A	B	C																							
F=0.1	Ignore																									
0.10< F=0.15	2																									
0.15< F=0.25	1																									
F> 0.25	0																									
11.4.2.3	Dim Spots Circle shaped and dim edged defects	<table border="1"> <thead> <tr> <th rowspan="2">Zone Size(mm)</th> <th colspan="3">Acceptable Qty</th> </tr> <tr> <th>A</th> <th>B</th> <th>C</th> </tr> </thead> <tbody> <tr> <td>F=0.2</td> <td colspan="3">Ignore</td> </tr> <tr> <td>0.20< F=0.4</td> <td colspan="3">2</td> </tr> <tr> <td>0.4< F=0.6</td> <td colspan="3">1</td> </tr> <tr> <td>F> 0.6</td> <td colspan="3">0</td> </tr> </tbody> </table>	Zone Size(mm)	Acceptable Qty			A	B	C	F=0.2	Ignore			0.20< F=0.4	2			0.4< F=0.6	1			F> 0.6	0			Minor
Zone Size(mm)	Acceptable Qty																									
	A	B	C																							
F=0.2	Ignore																									
0.20< F=0.4	2																									
0.4< F=0.6	1																									
F> 0.6	0																									
11.4.2.4	Dot defect	dot =sub-pixel <table border="1"> <thead> <tr> <th rowspan="2"></th> <th colspan="2">Acceptable Qty</th> </tr> <tr> <th>I</th> <th>II</th> </tr> </thead> <tbody> <tr> <td>Bright dot</td> <td>0</td> <td>2</td> </tr> <tr> <td>Dark dot</td> <td>1</td> <td>2</td> </tr> </tbody> </table> The distance of two point >5mm		Acceptable Qty		I	II	Bright dot	0	2	Dark dot	1	2	Minor												
	Acceptable Qty																									
	I	II																								
Bright dot	0	2																								
Dark dot	1	2																								

11.4.3 Cosmetic Defect (linear defect)

Item No	Items to be	Inspection Standard	Classification of defects																																	
11.4.3.1	Line defect Black line, White line, Foreign material on polarizer	<table border="1"> <thead> <tr> <th colspan="2">Size(mm)</th> <th colspan="3">Acceptable Qty</th> </tr> <tr> <th rowspan="2">L(Length)</th> <th rowspan="2">W(Width)</th> <th colspan="3">zone</th> </tr> <tr> <th>A</th> <th>B</th> <th>C</th> </tr> </thead> <tbody> <tr> <td>Ignore</td> <td>W=0.02</td> <td colspan="3">Ignore</td> </tr> <tr> <td>L=3.0</td> <td>0.02< W=0.03</td> <td colspan="3">2</td> </tr> <tr> <td>L=2.0</td> <td>0.03< W=0.05</td> <td colspan="3">1</td> </tr> <tr> <td></td> <td>W> 0.05</td> <td colspan="3">Define as spot defect</td> </tr> </tbody> </table>	Size(mm)		Acceptable Qty			L(Length)	W(Width)	zone			A	B	C	Ignore	W=0.02	Ignore			L=3.0	0.02< W=0.03	2			L=2.0	0.03< W=0.05	1				W> 0.05	Define as spot defect			Minor
		Size(mm)		Acceptable Qty																																
		L(Length)	W(Width)	zone																																
				A	B	C																														
		Ignore	W=0.02	Ignore																																
		L=3.0	0.02< W=0.03	2																																
L=2.0	0.03< W=0.05	1																																		
	W> 0.05	Define as spot defect																																		



11.4.3.2	Foreign Material on TP film	The line can be seen after mobile phone in the operating condition:			Minor		
		Size(mm)		Acceptable Qty			
		L(Length)	W(Width)	zone			
				A		B	C
		Ignore	W=0.03	Ignore		Ignore	
L=3.0	0.03 < W=0.05	3					
	W > 0.05	Define as spot defect					
11.4.3.3	Dim line defect Polarizer & BL scratch TP film scratch	If the scratch can be seen after mobile phone cover assembling or in the operating condition, judge by the line defect of 11.4.3.1. If the scratch can be seen only in non-operating condition or some special angle, judge by the following.			Minor		
		Size(mm)		Acceptable Qty			
		L(Length)	W(Width)	zone			
				A		B	C
		Ignore	W=0.02	Ignore		Ignore	
L=3.0	0.02 < W=0.03	2					
L=2.0	0.03 < W=0.05	1					
	W > 0.05	Define as spot defect					
11.4.3.4	Polarize Air bubble	Air bubbles between glass & polarizer			Minor		
			Acceptable Qty				
			A	B		C	
		F=0.2	Ignore			Ignore	
		0.20 < F=0.3	2				
0.3 < F=0.5	1						
F > 0.5	0						

11.4.4 Chipping Defect

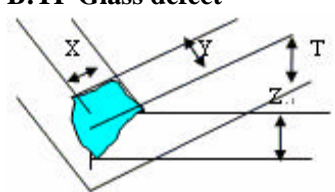
Item No	Items to be	Inspection Standard	Classification of defects												
11.4.4.1	Glass defect	<p>Chips on corner A: LCD Glass defect</p>  <table border="1" data-bbox="925 1646 1284 1736"> <tr> <td>X</td> <td>Y</td> <td>Z</td> </tr> <tr> <td>=0.2</td> <td>=S</td> <td>Disregard</td> </tr> </table> <p>Notes: S=contact pad length Chips on the corner of terminal shall not be allowed to extend into the ITO pad or expose perimeter seal.</p> <p>B: TP Glass defect</p>  <table border="1" data-bbox="925 1915 1284 2004"> <tr> <td>X</td> <td>Y</td> <td>Z</td> </tr> <tr> <td>=3.0</td> <td>=3.0</td> <td>Disregard</td> </tr> </table>	X	Y	Z	=0.2	=S	Disregard	X	Y	Z	=3.0	=3.0	Disregard	Minor
X	Y	Z													
=0.2	=S	Disregard													
X	Y	Z													
=3.0	=3.0	Disregard													



Usual surface cracks
A:LCD Glass defect

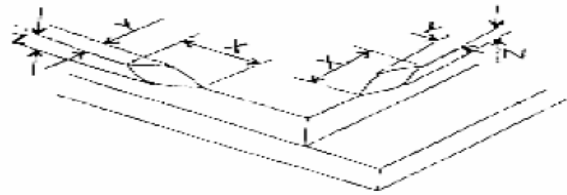

X	Y	Z
=3.0	<Inner border line of the seal	Disregard

B:TP Glass defect

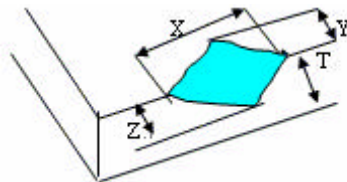

X	Y	Z
=6.0	=2.0	Disregard

Crack: Cracks tend to break are not allowed.

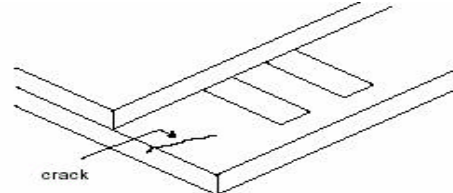

11.4.5 Parts Defect

Item No	Items to be	Inspection Standard	Classification of defects
11.4.5.1	Parts contra position	1、 Not allow IC and FPC/heat-seal lead width is more than 50% beyond lead pattern. 2、 Not allow chip or solder component is off center more than 50% of the pad outline.	Major
11.4.5.2	SMT	According to the <Acceptability of electronic assemblies>IPC-A-610C class 2 standard. Component missing or function defect are Major defect, the others are Minor defect.	Major
11.4.5.3	TP Defect	1、 Pattern font : Pattern fonts are clear and symmetrical , pattern fonts filter lightly are allowed; The fort line is not allow to thinner or thicker than 1/3 of normal size, and swing is not more than 0.1mm. the line is smooth and not broken.  Pattern font 2、 The wing forward in the side of Visual Area : The length of wing forward inside of the Visual Area: n=0.2mm ; Not excess 3 point , and the distance D=20mm.	Major

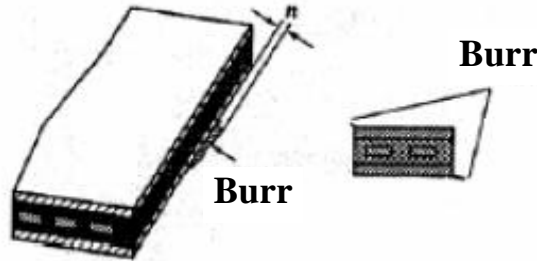

- 3、 Film impression: With operation, must be invisibility.
- 4、 Touch panel knob : if writing function normally, it could be allowed.



TP knob

- 5、 Newton ring
 - Without operation, the color circle of Regularity or Non-regularity from the normal or slope angle of view.
 - 1、 Regularity : The area of the newton ring is less than 1/3 area of the touch panel; and no character affected and line distorted after touch panel lightening. It's ok.
 - 2、 Non-regularity : The area of the Newton ring is less than the 1/2 area of touch panel with lightening. And no character affected and line



Regular



Irregular

11.4.5.4	Backlight elements	<ul style="list-style-type: none"> 1 Illumination source flickers when lit. 2 Spots or scratches that appear when lit must be judged using LCD spot, lines and contamination standards. 3 Backlight doesn't light or color is wrong 	Major
11.4.5.5	Soldering	<ul style="list-style-type: none"> 1 No unmelted solder paste may be present on the FPC 2 No cold solder joints, missing solder connections, oxidation or icicle. 3 No short circuits in components on FPC 	Major



11. Packing (Reference only)

Packing Method

(1) 6pcs modules/tray



(2) 6 tray stacking/lot

Coverd by empty tray



6tray /lot

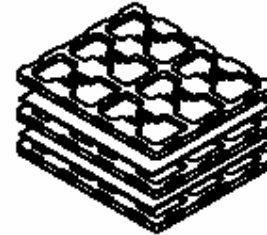

(3) 2 EPE cushion/lot

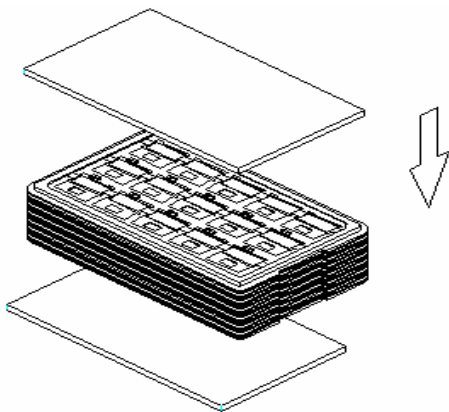

(4) Fixing by type

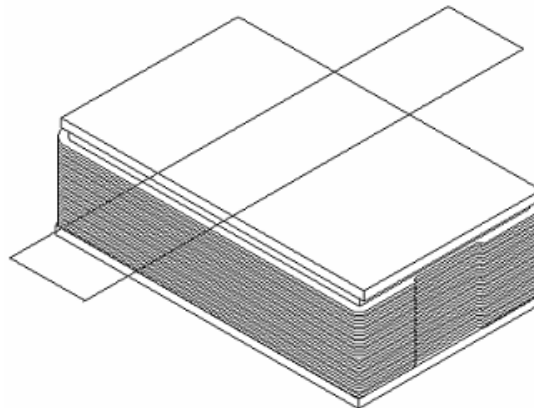

(5) 2 lot/internal box (72PCS)

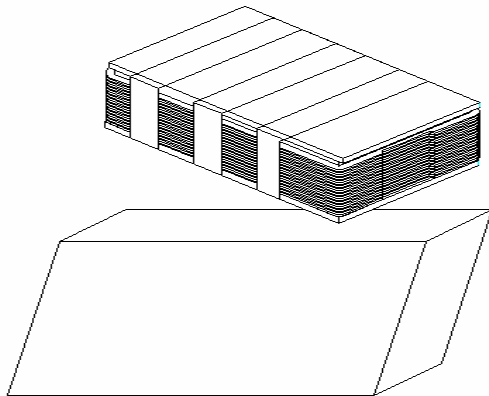

(6) 2 internal boxes/out box

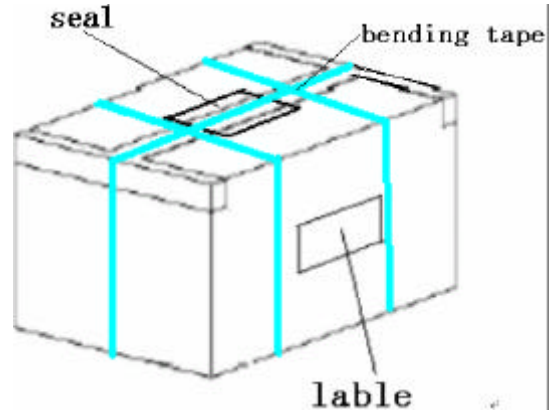

Size: 400.0x350.0x400.0mm

Total: 144pcs module/out box