

### MOS FIELD EFFECT TRANSISTOR

# 2SK4090

## SWITCHING N-CHANNEL POWER MOS FET

### DESCRIPTION

The 2SK4090 is N-channel MOS FET device that features a low on-state resistance and excellent switching characteristics, and designed for low voltage high current applications such as DC/DC converter with synchronous rectifier.

### FEATURES

- Low on-state resistance  
 $R_{DS(on)1} = 6.0 \text{ m}\Omega \text{ MAX. (} V_{GS} = 10 \text{ V, } I_D = 30 \text{ A)}$   
 $R_{DS(on)2} = 11 \text{ m}\Omega \text{ MAX. (} V_{GS} = 4.5 \text{ V, } I_D = 30 \text{ A)}$
- Low gate to drain charge  
 $Q_{GD} = 6 \text{ nC TYP. (} V_{DD} = 15 \text{ V, } I_D = 30 \text{ A)}$
- 4.5 V drive available
- Avalanche capability ratings

### ORDERING INFORMATION

| PART NUMBER                       | LEAD PLATING  | PACKING          | PACKAGE                     |
|-----------------------------------|---------------|------------------|-----------------------------|
| 2SK4090(1)-S27-AY <sup>Note</sup> | Pure Sn (Tin) | Tube 75 p/tube   | TO-251 (MP-3-b) typ. 0.34 g |
| 2SK4090-ZK-E1-AY <sup>Note</sup>  |               | Tape 2500 p/reel | TO-252 (MP-3ZK) typ. 0.27 g |
| 2SK4090-ZK-E2-AY <sup>Note</sup>  |               |                  |                             |

**Note** Pb-free (This product does not contain Pb in external electrode).

### ABSOLUTE MAXIMUM RATINGS (T<sub>A</sub> = 25°C)

|   |                       |             |    |
|---|-----------------------|-------------|----|
| Drain to Source Voltage (V <sub>GS</sub> = 0 V) | V <sub>DSS</sub>      | 30          | V  |
| Gate to Source Voltage (V <sub>DS</sub> = 0 V)  | V <sub>GSS</sub>      | ±20         | V  |
| Drain Current (DC) (T <sub>C</sub> = 25°C)      | I <sub>D(DC)</sub>    | ±64         | A  |
| Drain Current (pulse) <sup>Note1</sup>          | I <sub>D(pulse)</sub> | ±192        | A  |
| Total Power Dissipation (T <sub>C</sub> = 25°C) | P <sub>T1</sub>       | 36          | W  |
| Total Power Dissipation (T <sub>A</sub> = 25°C) | P <sub>T2</sub>       | 1.0         | W  |
| Channel Temperature                             | T <sub>ch</sub>       | 150         | °C |
| Storage Temperature                             | T <sub>stg</sub>      | -55 to +150 | °C |
| Single Avalanche Current <sup>Note2</sup>       | I <sub>AS</sub>       | 35          | A  |
| Single Avalanche Energy <sup>Note2</sup>        | E <sub>AS</sub>       | 122.5       | mJ |

(TO-251)

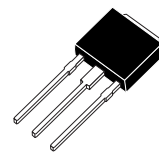

(TO-252)

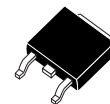

**Notes** 1. PW ≤ 10 μs, Duty Cycle ≤ 1%

2. Starting T<sub>ch</sub> = 25°C, V<sub>DD</sub> = 15 V, R<sub>G</sub> = 25 Ω, V<sub>GS</sub> = 20 → 0 V, L = 0.1 mH

The information in this document is subject to change without notice. Before using this document, please confirm that this is the latest version.  
 Not all products and/or types are available in every country. Please check with an NEC Electronics sales representative for availability and additional information.

**ELECTRICAL CHARACTERISTICS (T<sub>A</sub> = 25°C)**

| CHARACTERISTICS                                     | SYMBOL               | TEST CONDITIONS  | MIN. | TYP. | MAX. | UNIT |
|---|----------------------|--|------|------|------|------|
| Zero Gate Voltage Drain Current                     | I <sub>DSS</sub>     | V <sub>DS</sub> = 30 V, V <sub>GS</sub> = 0 V                          |      |      | 10   | μA   |
| Gate Leakage Current                                | I <sub>GSS</sub>     | V <sub>GS</sub> = ±20 V, V <sub>DS</sub> = 0 V                         |      |      | ±100 | nA   |
| Gate to Source Cut-off Voltage                      | V <sub>GS(off)</sub> | V <sub>DS</sub> = V <sub>GS</sub> , I <sub>D</sub> = 250 μA            | 1.5  | 2.0  | 2.5  | V    |
| Forward Transfer Admittance <sup>Note</sup>         | y <sub>fs</sub>      | V <sub>DS</sub> = 10 V, I <sub>D</sub> = 30 A                          | 13   | 19   |      | S    |
| Drain to Source On-state Resistance <sup>Note</sup> | R <sub>DS(on)1</sub> | V <sub>GS</sub> = 10 V, I <sub>D</sub> = 30 A                          |      | 5.1  | 6.0  | mΩ   |
|   | R <sub>DS(on)2</sub> | V <sub>GS</sub> = 4.5 V, I <sub>D</sub> = 30 A                         |      | 7.4  | 11   | mΩ   |
| Input Capacitance                                   | C <sub>iss</sub>     | V <sub>DS</sub> = 10 V,  |      | 2320 |      | pF   |
| Output Capacitance                                  | C <sub>oss</sub>     | V <sub>GS</sub> = 0 V,   |      | 380  |      | pF   |
| Reverse Transfer Capacitance                        | C <sub>rss</sub>     | f = 1 MHz  |      | 185  |      | pF   |
| Turn-on Delay Time                                  | t <sub>d(on)</sub>   | V <sub>DD</sub> = 15 V, I <sub>D</sub> = 30 A,                         |      | 15   |      | ns   |
| Rise Time   | t <sub>r</sub>       | V <sub>GS</sub> = 10 V,  |      | 14   |      | ns   |
| Turn-off Delay Time                                 | t <sub>d(off)</sub>  | R <sub>G</sub> = 3 Ω   |      | 49   |      | ns   |
| Fall Time   | t <sub>f</sub>       |  |      | 7    |      | ns   |
| Total Gate Charge                                   | Q <sub>G1</sub>      | V <sub>DD</sub> = 15 V, V <sub>GS</sub> = 10 V, I <sub>D</sub> = 30 A  |      | 36   |      | nC   |
|   | Q <sub>G2</sub>      | V <sub>DD</sub> = 15 V, V <sub>GS</sub> = 4.5 V, I <sub>D</sub> = 30 A |      | 17   |      | nC   |
| Gate to Source Charge                               | Q <sub>GS</sub>      | V <sub>DD</sub> = 15 V, I <sub>D</sub> = 30 A                          |      | 7    |      | nC   |
| Gate to Drain Charge                                | Q <sub>GD</sub>      |  |      | 6    |      | nC   |
| Gate Resistance                                     | R <sub>G</sub>       |  |      | 2.6  |      | Ω    |
| Body Diode Forward Voltage <sup>Note</sup>          | V <sub>F(S-D)</sub>  | I <sub>F</sub> = 30 A, V <sub>GS</sub> = 0 V                           |      | 0.86 | 1.5  | V    |
| Reverse Recovery Time                               | t <sub>rr</sub>      | I <sub>F</sub> = 30 A, V <sub>GS</sub> = 0 V,                          |      | 30   |      | ns   |
| Reverse Recovery Charge                             | Q <sub>rr</sub>      | di/dt = 100 A/μs   |      | 26   |      | nC   |

**Note** Pulsed

**TEST CIRCUIT 1 AVALANCHE CAPABILITY**

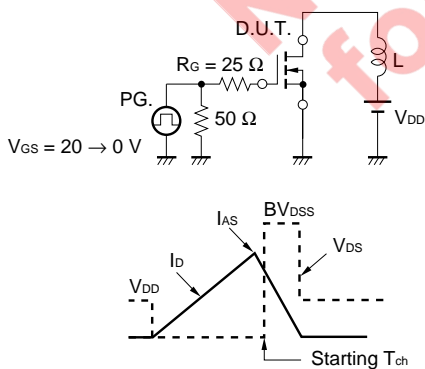

**TEST CIRCUIT 2 SWITCHING TIME**

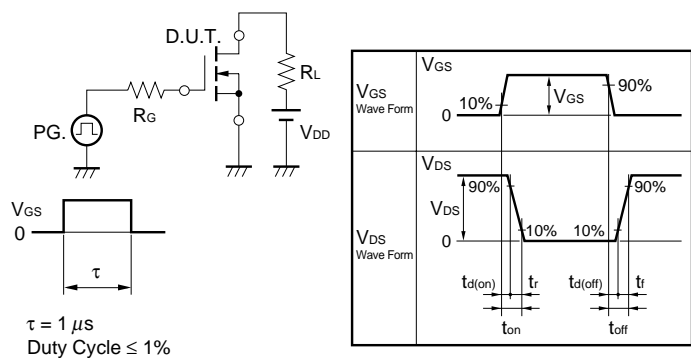

**TEST CIRCUIT 3 GATE CHARGE**

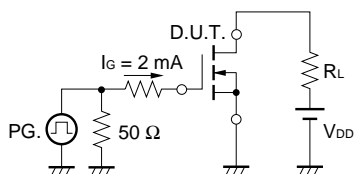

TYPICAL CHARACTERISTICS (T<sub>A</sub> = 25°C)

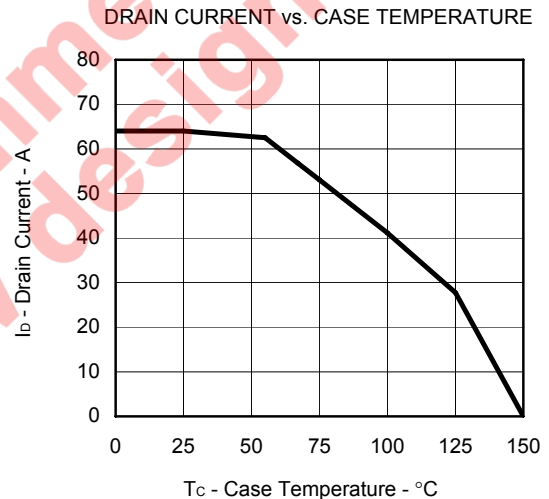
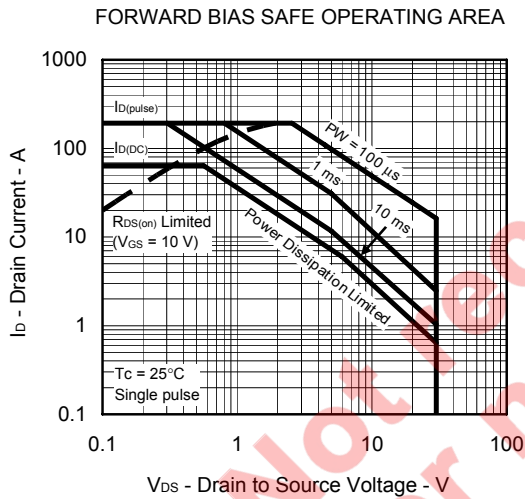
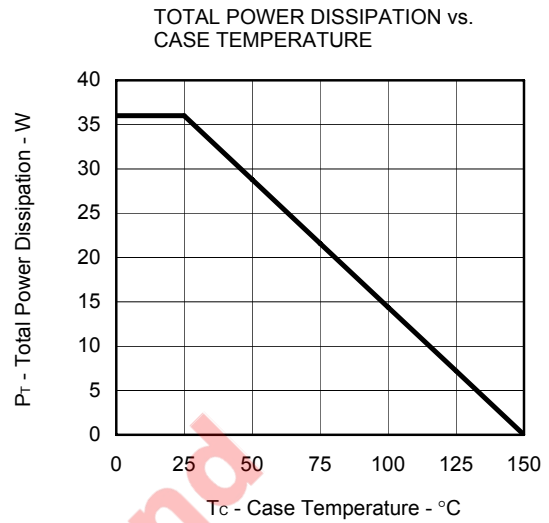
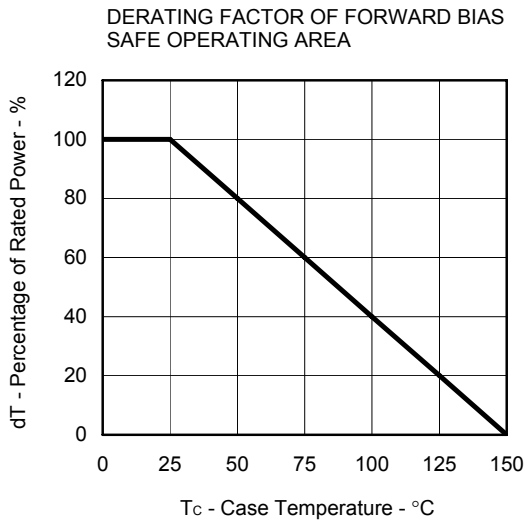

TRANSIENT THERMAL RESISTANCE vs. PULSE WIDTH

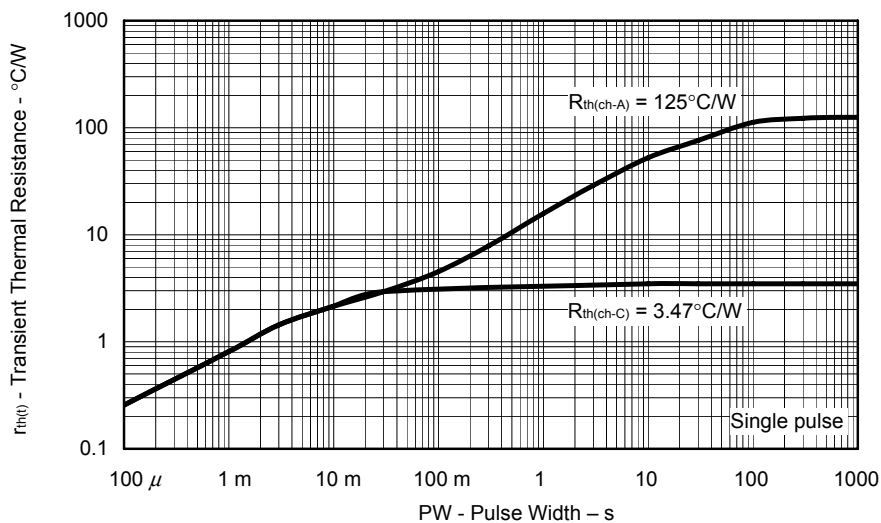

DRAIN CURRENT vs. DRAIN TO SOURCE VOLTAGE

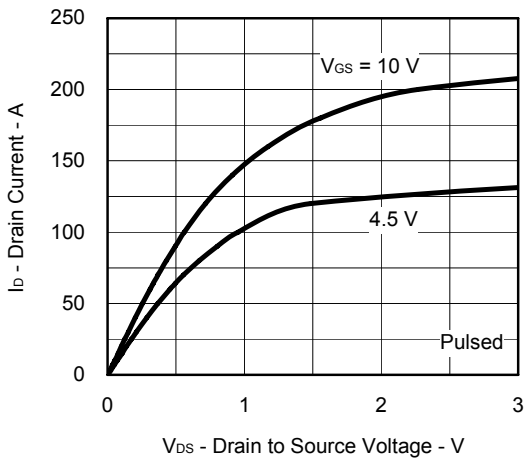

FORWARD TRANSFER CHARACTERISTICS

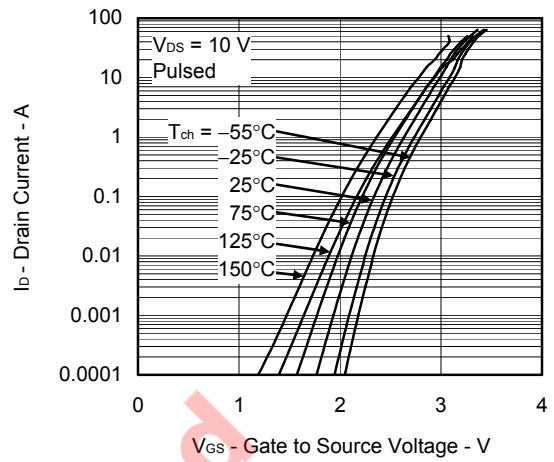

GATE TO SOURCE CUT-OFF VOLTAGE vs. CHANNEL TEMPERATURE

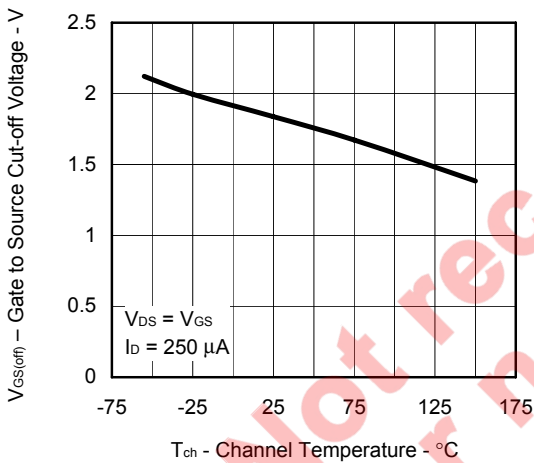

FORWARD TRANSFER ADMITTANCE vs. DRAIN CURRENT

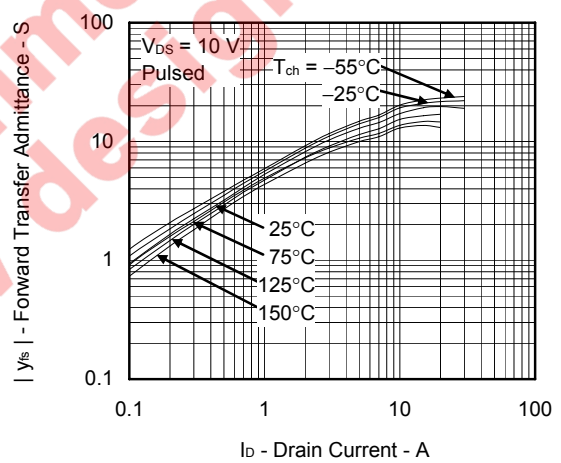

DRAIN TO SOURCE ON-STATE RESISTANCE vs. GATE TO SOURCE VOLTAGE

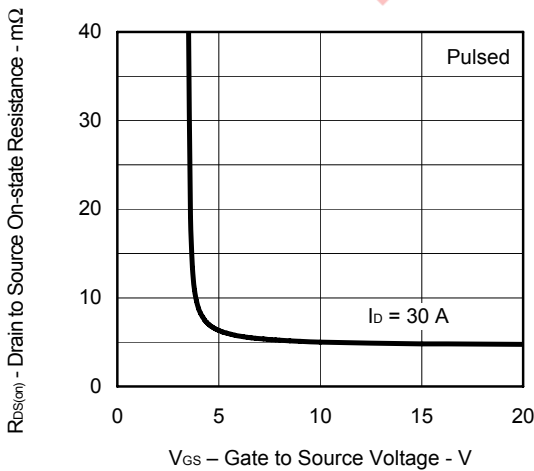

DRAIN TO SOURCE ON-STATE RESISTANCE vs. DRAIN CURRENT

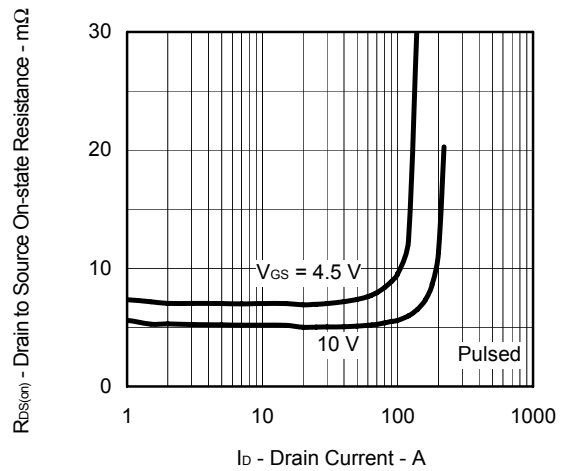

DRAIN TO SOURCE ON-STATE RESISTANCE vs. CHANNEL TEMPERATURE

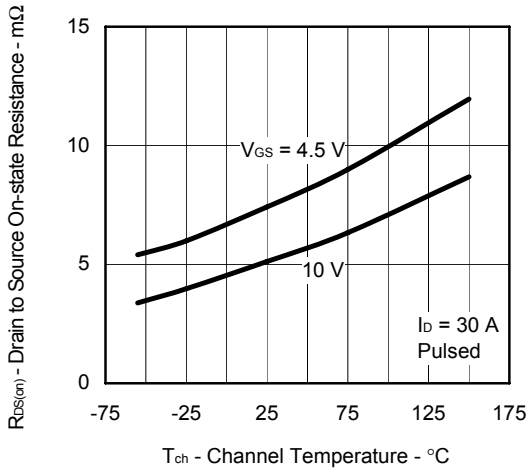

CAPACITANCE vs. DRAIN TO SOURCE VOLTAGE

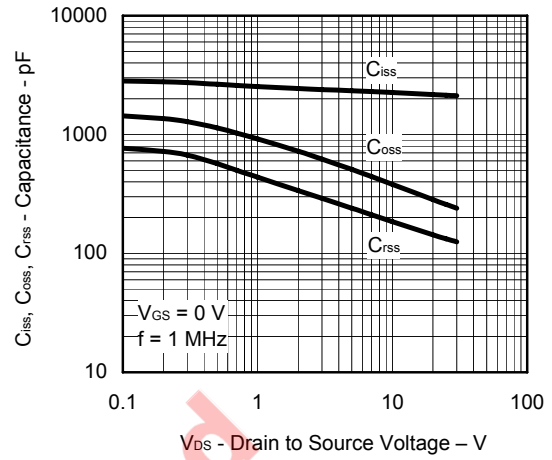

SWITCHING CHARACTERISTICS

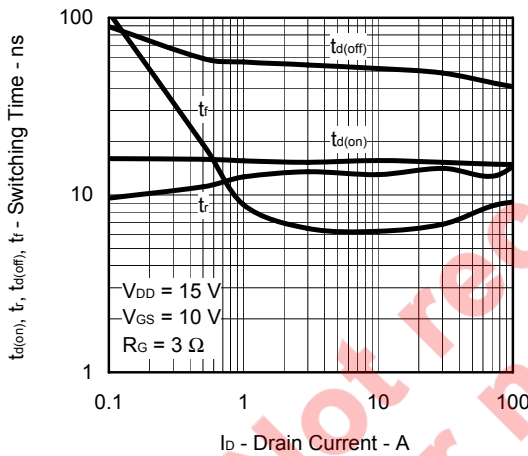

DYNAMIC INPUT/OUTPUT CHARACTERISTICS

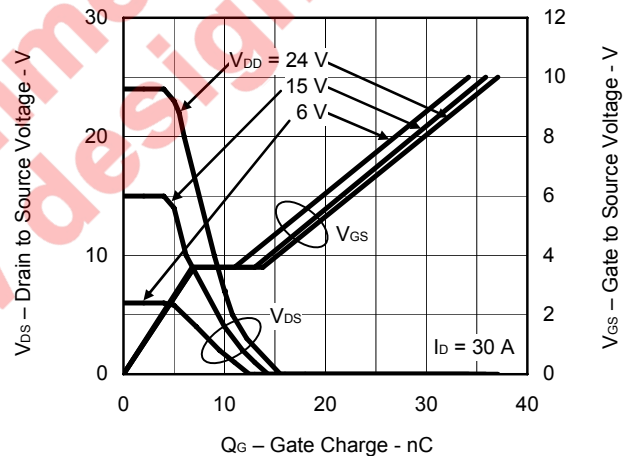

SOURCE TO DRAIN DIODE FORWARD VOLTAGE

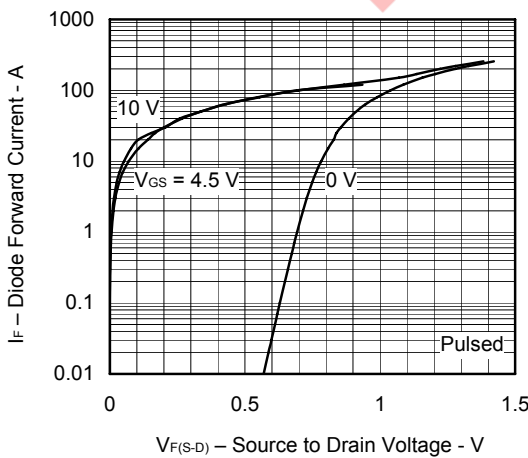

REVERSE RECOVERY TIME vs. DIODE FORWARD CURRENT

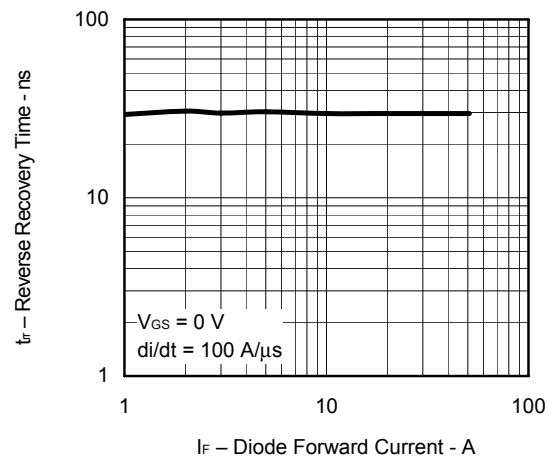

SINGLE AVALANCHE CURRENT vs. INDUCTIVE LOAD

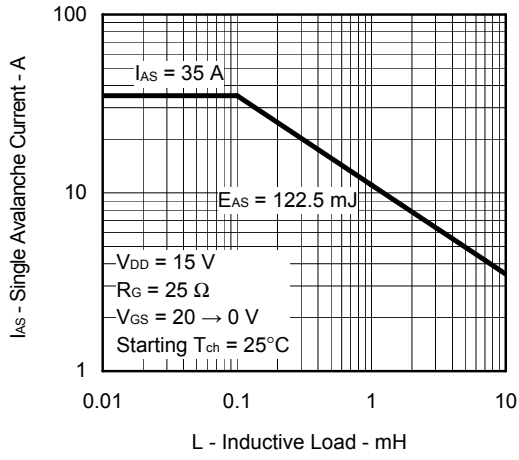

SINGLE AVALANCHE ENERGY DERATING FACTOR

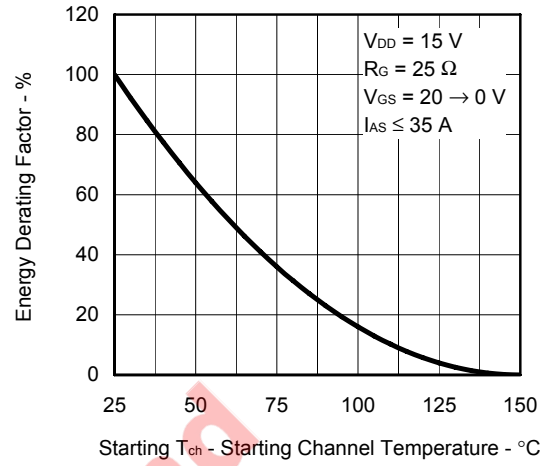

Not recommended for new design

PACKAGE DRAWINGS (Unit: mm)

1) TO-251 (MP-3-b)

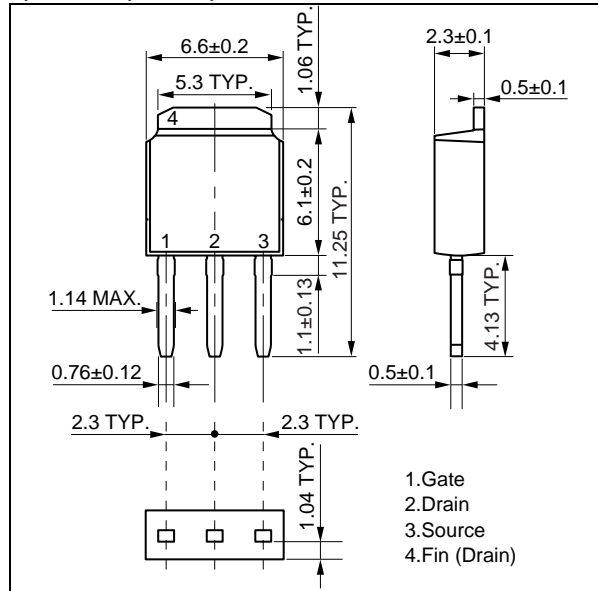

2) TO-252 (MP-3ZK)

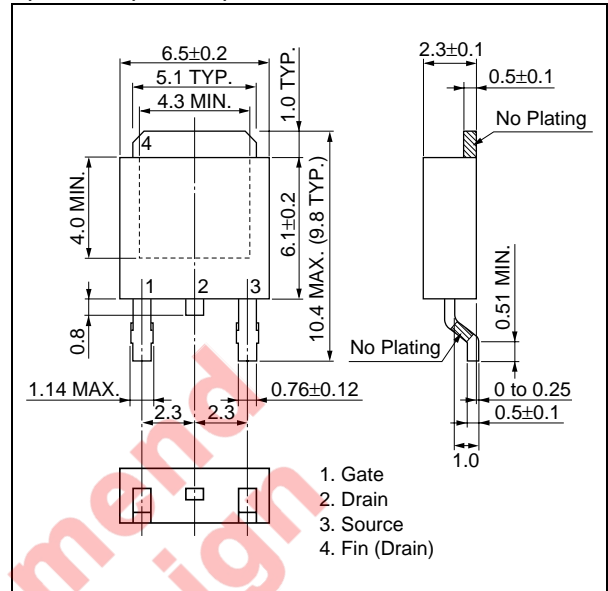

EQUIVALENT CIRCUIT

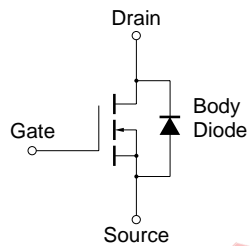

**Remark** Strong electric field, when exposed to this device, can cause destruction of the gate oxide and ultimately degrade the device operation. Steps must be taken to stop generation of static electricity as much as possible, and quickly dissipate it once, when it has occurred.