

Document Title

**1Mx4 Bit High Speed Static RAM(3.3V Operating).
Operated at Commercial and Industrial Temperature Ranges.**

Revision History

<u>RevNo.</u>	<u>History</u>	<u>Draft Data</u>	<u>Remark</u>
Rev. 0.0	Initial release with Preliminary.	Aug. 20. 2001	Preliminary
Rev. 0.1	Add Low Ver.	Sep. 19. 2001	Preliminary
Rev. 1.0	Change Icc, Isb and Isb1	Nov. 3. 2001	Preliminary

Item		Previous	Current
ICC(Commercial)	8ns	110mA	80mA
	10ns	90mA	65mA
	12ns	80mA	55mA
	15ns	70mA	45mA
ICC(Industrial)	8ns	130mA	100mA
	10ns	115mA	85mA
	12ns	100mA	75mA
	15ns	85mA	65mA
ISB		30mA	20mA
ISB1(L-ver.)		0.5mA	1.2mA

Rev. 0.3	1. Correct AC parameters : Read & Write Cycle mA 2. Delete Low Ver. 3. Delete Data Retention Characteristics	Nov.23. 2001	Preliminary
----------	--	--------------	-------------

Rev. 1.0	1. Delete 12ns,15ns speed bin. 2. Change Icc for Industrial mode.	Dec.18. 2001	Final
----------	--	--------------	-------

Item		Previous	Current
ICC(Industrial)	8ns	100mA	90mA
	10ns	85mA	75mA

Rev. 2.0	1. Add the Lead Free Package type.	July. 26, 2004	Final
----------	------------------------------------	----------------	-------

The attached data sheets are prepared and approved by SAMSUNG Electronics. SAMSUNG Electronics CO., LTD. reserve the right to change the specifications. SAMSUNG Electronics will evaluate and reply to your requests and questions on the parameters of this device. If you have any questions, please contact the SAMSUNG branch office near your office, call or contact Headquarters.

4Mb Async. Fast SRAM Ordering Information

Org.	Part Number	VDD(V)	Speed (ns)	PKG	Temp. & Power
1M x4	K6R4004C1D-J(K)C(I) 10	5	10	J : 32-SOJ	C : Commercial Temperature ,Normal Power Range I : Industrial Temperature ,Normal Power Range L : Commercial Temperature ,Low Power Range P : Industrial Temperature ,Low Power Range
	K6R4004V1D-J(K)C(I) 08/10	3.3	8/10	K : 32-SOJ(LF)	
512K x8	K6R4008C1D-J(K,T,U)C(I) 10	5	10	J : 36-SOJ	
	K6R4008V1D-J(K,T,U)C(I) 08/10	3.3	8/10	K : 36-SOJ(LF) T : 44-TSOP2 U : 44-TSOP2(LF)	
256K x16	K6R4016C1D-J(K,T,U,E)C(I) 10	5	10	J : 44-SOJ	
	K6R4016V1D-J(K,T,U,E)C(I,L,P) 08/10	3.3	8/10	K : 44-SOJ(LF) T : 44-TSOP2 U : 44-TSOP2(LF) E : 48-TBGA	

1M x 4 Bit (with \overline{OE}) High-Speed CMOS Static RAM

FEATURES

- Fast Access Time 8,10ns(Max.)
- Low Power Dissipation
 - Standby (TTL) :20mA(Max.)
 - (CMOS) : 5mA(Max.)
 - Operating K6R4004V1D-08: 80mA(Max.)
 - K6R4004V1D-10: 65mA(Max.)
- Single 3.3±0.3V Power Supply
- TTL Compatible Inputs and Outputs
- Fully Static Operation
 - No Clock or Refresh required
- Three State Outputs
- Center Power/Ground Pin Configuration
- Standard Pin Configuration
 - K6R4004V1D-J: 32-SOJ-400
 - K6R4004V1D-K: 32-SOJ-400(Lead-Free)
- Operating in Commercial and Industrial Temperature range.

GENERAL DESCRIPTION

The K6R4004V1D is a 4,194,304-bit high-speed Static Random Access Memory organized as 1,048,576 words by 4 bits. The K6R4004V1D uses 4 common input and output lines and has an output enable pin which operates faster than address access time at read cycle. The device is fabricated using SAMSUNG's advanced CMOS process and designed for high-speed circuit technology. It is particularly well suited for use in high-density high-speed system applications. The K6R4004V1D is packaged in a 400 mil 32-pin plastic SOJ.

FUNCTIONAL BLOCK DIAGRAM

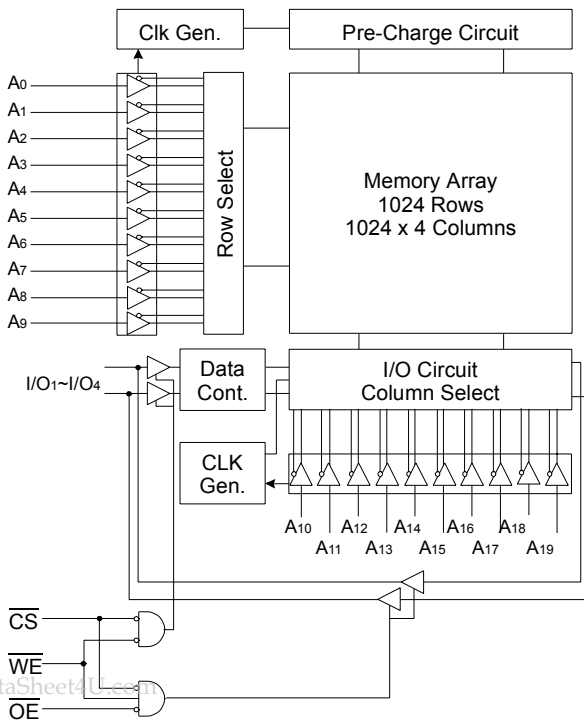

PIN CONFIGURATION (Top View)

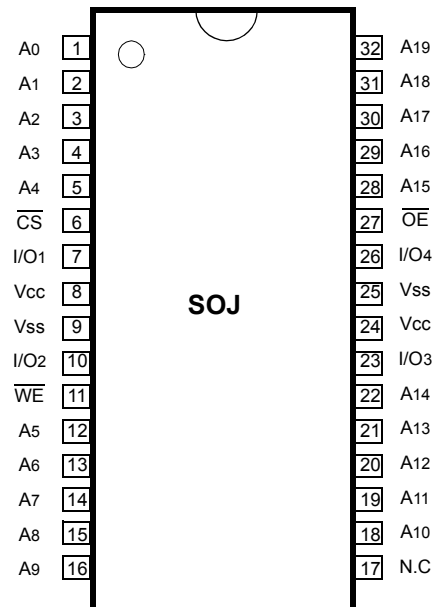

PIN FUNCTION

Pin Name	Pin Function
A0 - A19	Address Inputs
\overline{WE}	Write Enable
\overline{CS}	Chip Select
\overline{OE}	Output Enable
I/O1 ~ I/O4	Data Inputs/Outputs
Vcc	Power(+3.3V)
Vss	Ground
N.C	No Connection

ABSOLUTE MAXIMUM RATINGS*

Parameter		Symbol	Rating	Unit
Voltage on Any Pin Relative to Vss		V _{IN} , V _{OUT}	-0.5 to 4.6	V
Voltage on Vcc Supply Relative to Vss		V _{CC}	-0.5 to 4.6	V
Power Dissipation		P _D	1.0	W
Storage Temperature		T _{STG}	-65 to 150	°C
Operating Temperature	Commercial	T _A	0 to 70	°C
	Industrial	T _A	-40 to 85	°C

* Stresses greater than those listed under "Absolute Maximum Ratings" may cause permanent damage to the device. This is a stress rating only and functional operation of the device at these or any other conditions above those indicated in the operating sections of this specification is not implied. Exposure to absolute maximum rating conditions for extended periods may affect reliability.

RECOMMENDED DC OPERATING CONDITIONS*(T_A=0 to 70°C)

Parameter	Symbol	Min	Typ	Max	Unit
Supply Voltage	V _{CC}	3.0	3.3	3.6	V
Ground	V _{SS}	0	0	0	V
Input High Voltage	V _{IH}	2.0	-	V _{CC} +0.3**	V
Input Low Voltage	V _{IL}	-0.3*	-	0.8	V

* The above parameters are also guaranteed at industrial temperature range.

** V_{IL}(Min) = -2.0V a.c(Pulse Width ≤ 8ns) for I ≤ 20mA.

*** V_{IH}(Max) = V_{CC} + 2.0V a.c (Pulse Width ≤ 8ns) for I ≤ 20mA.

DC AND OPERATING CHARACTERISTICS*(T_A=0 to 70°C, V_{CC}=3.3±0.3V, unless otherwise specified)

Parameter	Symbol	Test Conditions		Min	Max	Unit	
Input Leakage Current	I _{LI}	V _{IN} =V _{SS} to V _{CC}		-2	2	μA	
Output Leakage Current	I _{LO}	$\overline{CS}=V_{IH}$ or $\overline{OE}=V_{IH}$ or $\overline{WE}=V_{IL}$ V _{OUT} =V _{SS} to V _{CC}		-2	2	μA	
Operating Current	I _{CC}	Min. Cycle, 100% Duty $\overline{CS}=V_{IL}$, V _{IN} =V _{IH} or V _{IL} , I _{OUT} =0mA	Com.	8ns	-	80	mA
				10ns	-	65	
			Ind.	8ns	-	90	
				10ns	-	75	
Standby Current	I _{SB}	Min. Cycle, $\overline{CS}=V_{IH}$		-	20	mA	
	I _{SB1}	f=0MHz, $\overline{CS} \geq V_{CC}-0.2V$, V _{IN} ≥ V _{CC} -0.2V or V _{IN} ≤ 0.2V		-	5		
Output Low Voltage Level	V _{OL}	I _{OL} =8mA		-	0.4	V	
Output High Voltage Level	V _{OH}	I _{OH} =-4mA		2.4	-	V	

* The above parameters are also guaranteed at industrial temperature range.

CAPACITANCE*(T_A=25°C, f=1.0MHz)

Item	Symbol	Test Conditions	TYP	Max	Unit
Input/Output Capacitance	C _{I/O}	V _{I/O} =0V	-	8	pF
Input Capacitance	C _{IN}	V _{IN} =0V	-	6	pF

* Capacitance is sampled and not 100% tested.

AC CHARACTERISTICS (TA=0 to 70°C, VCC=3.3±0.3V, unless otherwise noted.)

TEST CONDITIONS*

Parameter	Value
Input Pulse Levels	0V to 3V
Input Rise and Fall Times	3ns
Input and Output timing Reference Levels	1.5V
Output Loads	See below

* The above test conditions are also applied at industrial temperature range.

Output Loads(A)

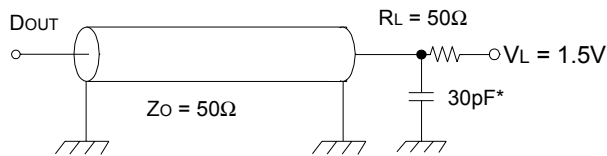

Output Loads(B)
for tHZ, tLZ, tWHZ, tOW, tOLZ & tOHZ

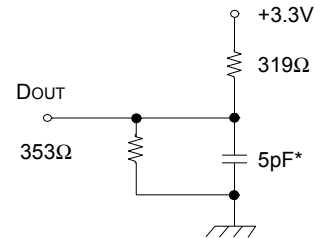

* Capacitive Load consists of all components of the test environment.

* Including Scope and Jig Capacitance

READ CYCLE*

Parameter	Symbol	K6R4004V1D-08		K6R4004V1D-10		Unit
		Min	Max	Min	Max	
Read Cycle Time	tRC	8	-	10	-	ns
Address Access Time	tAA	-	8	-	10	ns
Chip Select to Output	tCO	-	8	-	10	ns
Output Enable to Valid Output	tOE	-	4	-	5	ns
Chip Enable to Low-Z Output	tLZ	3	-	3	-	ns
Output Enable to Low-Z Output	tOLZ	0	-	0	-	ns
Chip Disable to High-Z Output	tHZ	0	4	0	5	ns
Output Disable to High-Z Output	tOHZ	0	4	0	5	ns
Output Hold from Address Change	tOH	3	-	3	-	ns
Chip Selection to Power Up Time	tPU	0	-	0	-	ns
Chip Selection to Power Down Time	tPD	-	8	-	10	ns

* The above parameters are also guaranteed at industrial temperature range.

WRITE CYCLE*

Parameter	Symbol	K6R4004V1D-08		K6R4004V1D-10		Unit
		Min	Max	Min	Max	
Write Cycle Time	t _{WC}	8	-	10	-	ns
Chip Select to End of Write	t _{CW}	6	-	7	-	ns
Address Set-up Time	t _{AS}	0	-	0	-	ns
Address Valid to End of Write	t _{AW}	6	-	7	-	ns
Write Pulse Width(\overline{OE} High)	t _{WP}	6	-	7	-	ns
Write Pulse Width(\overline{OE} Low)	t _{WP1}	8	-	10	-	ns
Write Recovery Time	t _{WR}	0	-	0	-	ns
Write to Output High-Z	t _{WHZ}	0	4	0	5	ns
Data to Write Time Overlap	t _{DW}	4	-	5	-	ns
Data Hold from Write Time	t _{DH}	0	-	0	-	ns
End of Write to Output Low-Z	t _{OW}	3	-	3	-	ns

* The above parameters are also guaranteed at industrial temperature range.

TIMING DIAGRAMS

TIMING WAVEFORM OF READ CYCLE(1) (Address Controlled, $\overline{CS}=\overline{OE}=V_{IL}$, $\overline{WE}=V_{IH}$)

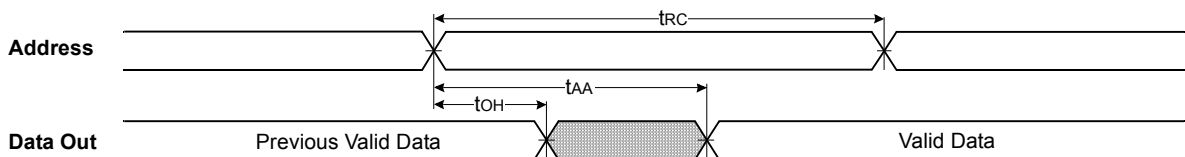

TIMING WAVEFORM OF READ CYCLE(2) ($\overline{WE}=V_{IH}$)

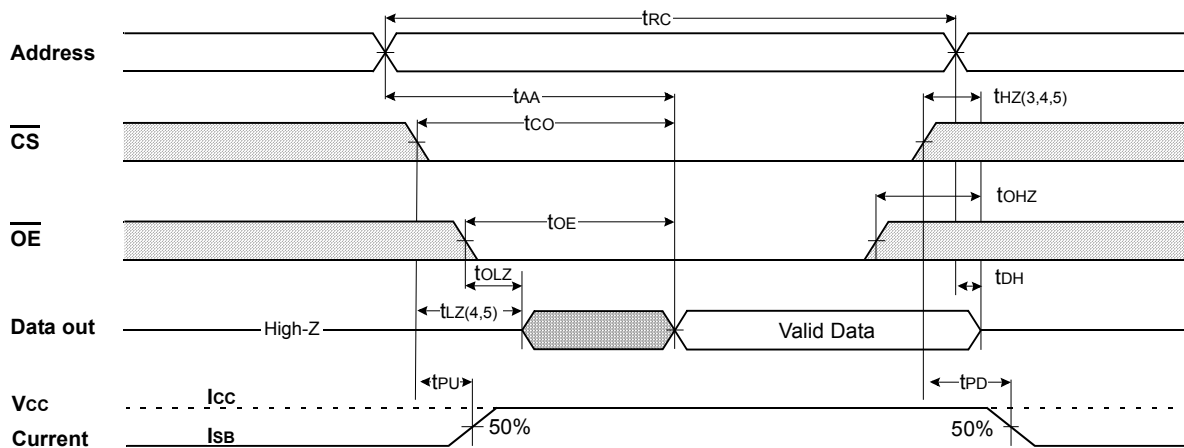

NOTES(READ CYCLE)

1. \overline{WE} is high for read cycle.
2. All read cycle timing is referenced from the last valid address to the first transition address.
3. t_{thz} and t_{ohz} are defined as the time at which the outputs achieve the open circuit condition and are not referenced to V_{OH} or V_{OL} levels.
4. At any given temperature and voltage condition, t_{thz}(Max.) is less than t_{tlz}(Min.) both for a given device and from device to device.
5. Transition is measured ±200mV from steady state voltage with Load(B). This parameter is sampled and not 100% tested.
6. Device is continuously selected with $\overline{CS}=V_{IL}$.
7. Address valid prior to coincident with \overline{CS} transition low.
8. For common I/O applications, minimization or elimination of bus contention conditions is necessary during read and write cycle.

TIMING WAVEFORM OF WRITE CYCLE(1) (\overline{OE} =Clock)

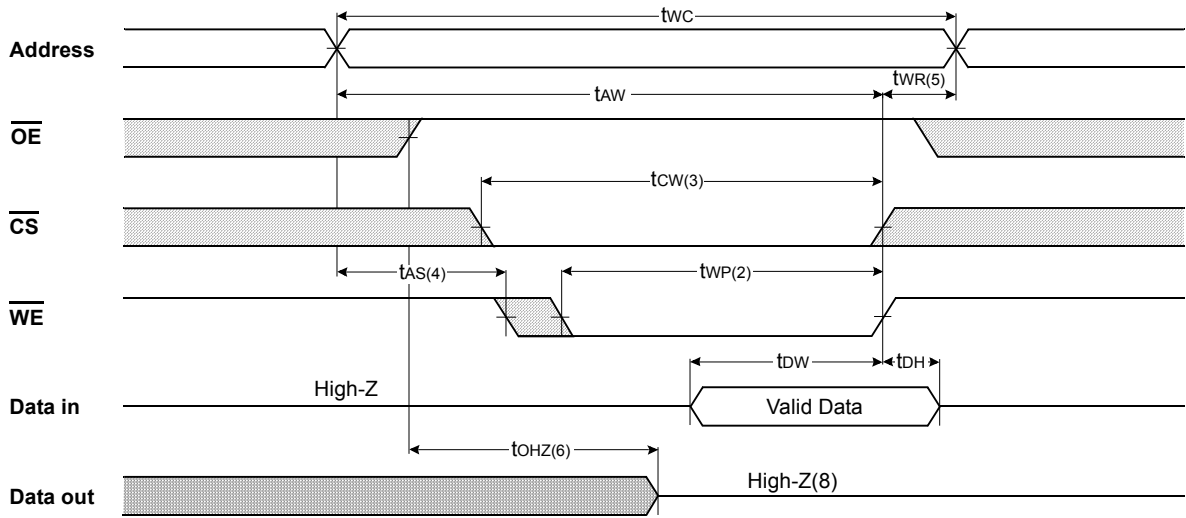

TIMING WAVEFORM OF WRITE CYCLE(2) (\overline{OE} =Low Fixed)

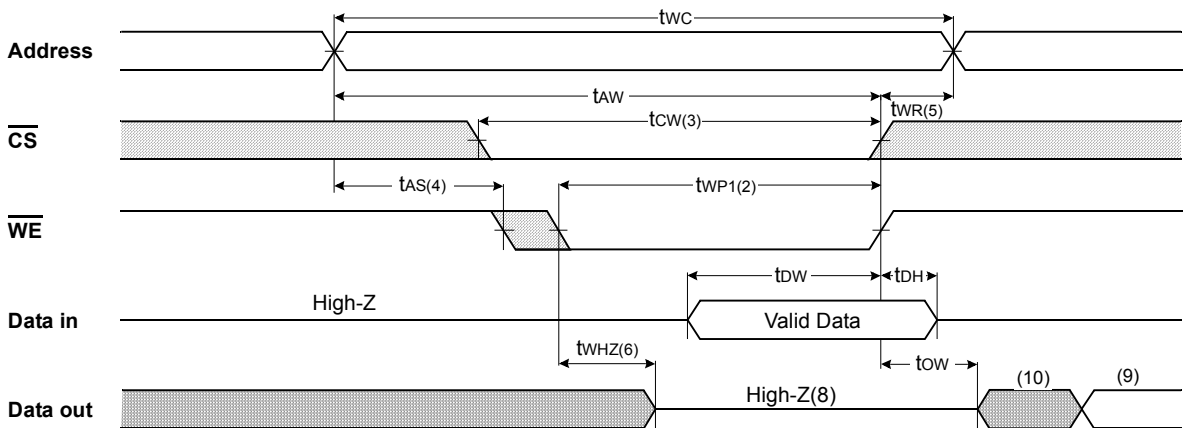

TIMING WAVEFORM OF WRITE CYCLE(3) (\overline{CS} =Controlled)

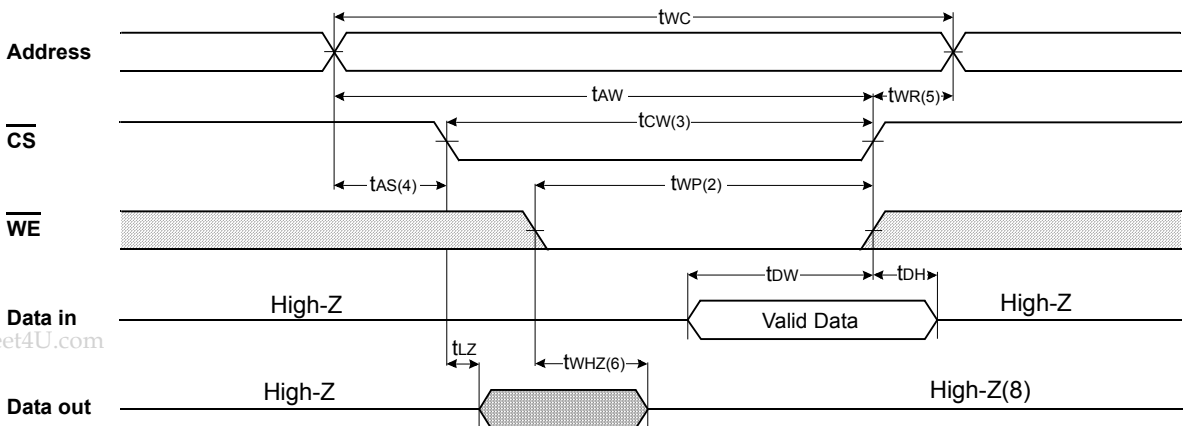

www.DataSheet4U.com

NOTES(WRITE CYCLE)

1. All write cycle timing is referenced from the last valid address to the first transition address.
2. A write occurs during the overlap of a low \overline{CS} and \overline{WE} . A write begins at the latest transition \overline{CS} going low and \overline{WE} going low ; A write ends at the earliest transition \overline{CS} going high or \overline{WE} going high. t_{WP} is measured from the beginning of write to the end of write.
3. t_{CW} is measured from the later of \overline{CS} going low to end of write.
4. t_{AS} is measured from the address valid to the beginning of write.
5. t_{WR} is measured from the end of write to the address change. t_{WR} applied in case a write ends as \overline{CS} or \overline{WE} going high.
6. If \overline{OE} , \overline{CS} and \overline{WE} are in the Read Mode during this period, the I/O pins are in the output low-Z state. Inputs of opposite phase of the output must not be applied because bus contention can occur.
7. For common I/O applications, minimization or elimination of bus contention conditions is necessary during read and write cycle.
8. If \overline{CS} goes low simultaneously with \overline{WE} going or after \overline{WE} going low, the outputs remain high impedance state.
9. Dout is the read data of the new address.
10. When \overline{CS} is low : I/O pins are in the output state. The input signals in the opposite phase leading to the output should not be applied.

FUNCTIONAL DESCRIPTION

\overline{CS}	\overline{WE}	\overline{OE}	Mode	I/O Pin	Supply Current
H	X	X*	Not Select	High-Z	ISB, ISB1
L	H	H	Output Disable	High-Z	I _{CC}
L	H	L	Read	DOUT	I _{CC}
L	L	X	Write	DIN	I _{CC}

* X means Don't Care.

