

INTRODUCTION

The KA22426D is a monolithic integrated circuit designed for radio-cassette tape recorders, clock radios and headphone radios.

FUNCTIONS

- AM/FM RF AMP
- AM AGC Control
- Audio Power AMP
- DC Volume
- FM Quadrature DET
- Local OSC
- FM AFC Control
- Tuning Indicator
- AM/FM IF AMP
- AM DET

FEATURES

- Built-in AM/FM Switching Circuit
- Wide operating supply voltage: $V_{CC} = 2V \sim 7.5V$
- Low current consumption ($V_{CC} = 3V$)
 - FM: $I_{CCQ} = 5.3 \text{ mA (Typ)}$
 - AM: $I_{CCQ} = 3.4 \text{ mA (Typ)}$
- High Power Audio Amplifier: 0.5W (typ) at $V_{CC} = 6V$, $R_L = 8\Omega$, THD = 10%

ORDERING INFORMATION

Device	Package	Operating Temperature
KA22426D	28-SOP-375	-20°C ~ +70°C

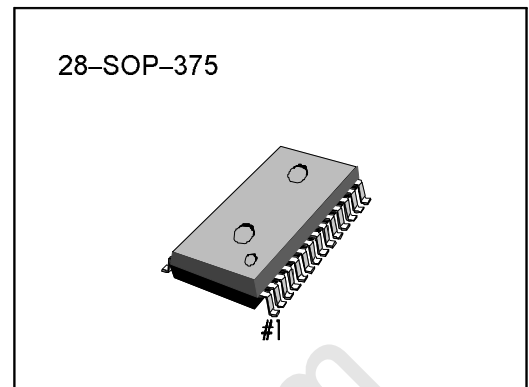

BLOCK DIAGRAM

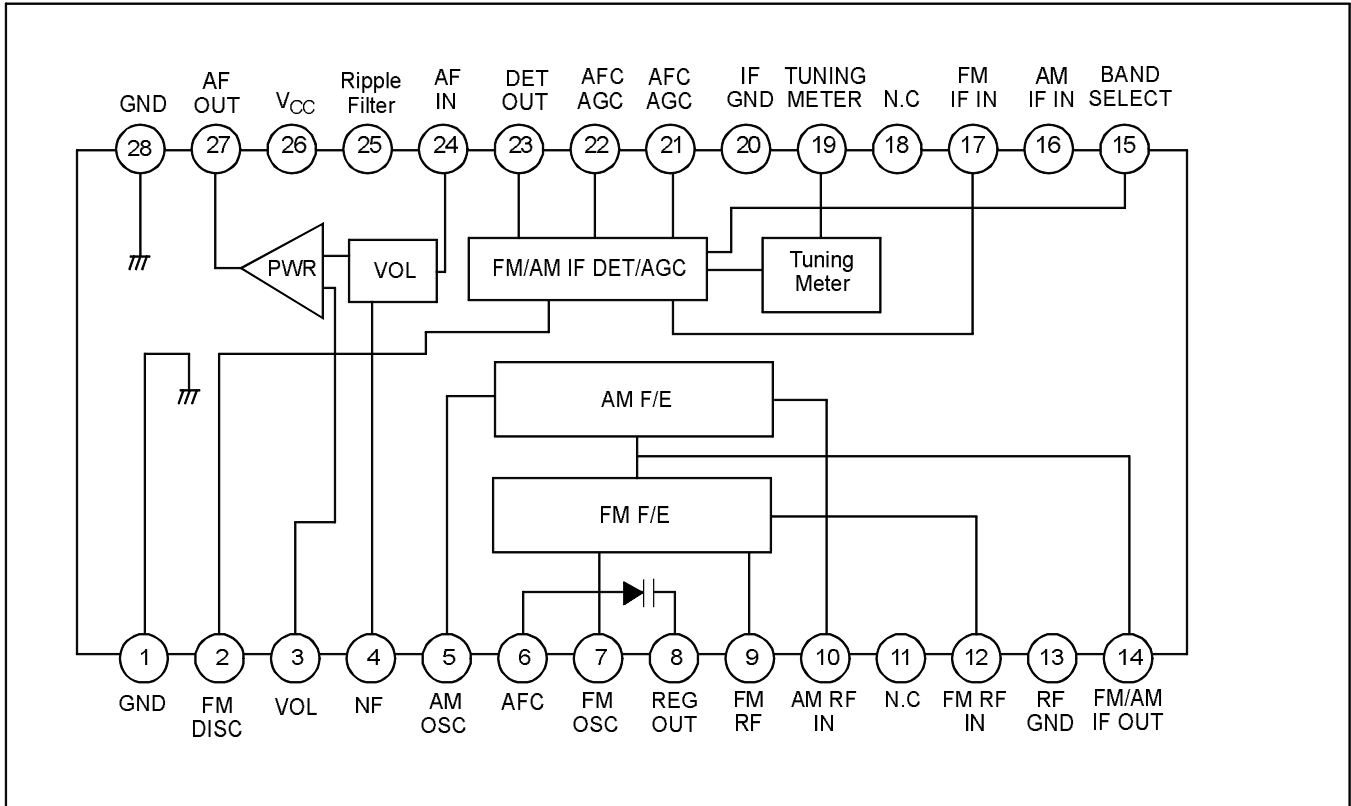

Figure 1.

ABSOLUTE MAXIMUM RATINGS (Ta = 25°C)

Characteristic	Symbol	Value	Unit
Supply Voltage	V _{CC}	9	V
Power Dissipation	P _D	1000	mW
Operating Temperature	T _{OPR}	-20 ~ +70	°C
Storage Temperature	T _{STG}	-40 ~ +125	°C

ELECTRICAL CHARACTERISTICS

($V_{CC} = 6V$, $T_a = 25^\circ C$, FM; $f = 22.5kHz$, $f_m = 1kHz$, AM; 30% Mod, unless otherwise specified)

	Characteristic	Symbol	Test Condition	Min.	Typ.	Max.	Unit
FM	Quiescent Circuit Current	I_{CCQ}	$V_I = 0$	–	7.0	14.0	mA
	F/E Voltage Gain	G_{V1V}	$V_I(1) = 40dB\mu$, $f_c = 100MHz$, $\Delta f = 0$	32	39	46	dB
	Detect Output Gain	$V_O(1)$	$V_I(3) = 90dB\mu$, $f_i = 10.7MHz$	–26	–20	–14	dBm
	IF-3 dB Sensitivity	$V_{I(LIM)}$	$V_O(VI3) = 90dB\mu$, $-3 dB$, $f_i = 10.7MHz$	–	24	32	dB μ
	Total Harmonic Distortion	THD_1	$V_I(3) = 90dB\mu$, $f_i = 10.7MHz(\Delta f = 75kHz)$	–	0.3	2.0	%
	Meter Drive Current	$I_M(1)$	$V_I(3) = 60dB\mu$, $f_i = 10.7MHz$	1.8	3.5	7.0	mA
AM	Quiescent Circuit Current	$I_{CCQ(2)}$	$V_I = 0$	–	3.5	10.0	mA
	F/E Voltage Gain	$G_V(2)$	$V_I(2) = 60dB\mu$, $f_c = 1660kHz$, $m = 0\%$	15	22	29	dB
	IF Voltage Gain	$G_V(3)$	$V_O(3) = -34dBm$, $f_i = 455kHz$	14	20	27	dB μ
	AM Detect Output Voltage	$V_O(2)$	$V_I(3) = 85dB\mu$, $f_i = 455kHz$	–26	–20	–14	dBm
	Total Harmonic Distortion	THD_2	$V_I(2) = 95dB\mu$, $f_c = 1660kHz$, $V_{CC} = 7.8V$	–	0.6	2.0	%
	Meter Drive Current	$I_M(2)$	$V_I(3) = 85dB\mu$, $f_i = 455kHz$	1.3	3.0	7.0	mA
AF	Closed Loop Voltage Gain	$G_V(4)$	$V_O(4) = 0dBm$, $f = 1kHz$	27	31.5	36	dB
	Total Harmonic Distortion	THD_3	$P_O = 50mW$, $f = 1kHz$	–	0.3	2.5	%
	Output Power	P_O	$R_L = 8\Omega$, $THD = 10\%$, $f = 1kHz$	0.4	0.5	–	W

APPLICATION CIRCUIT

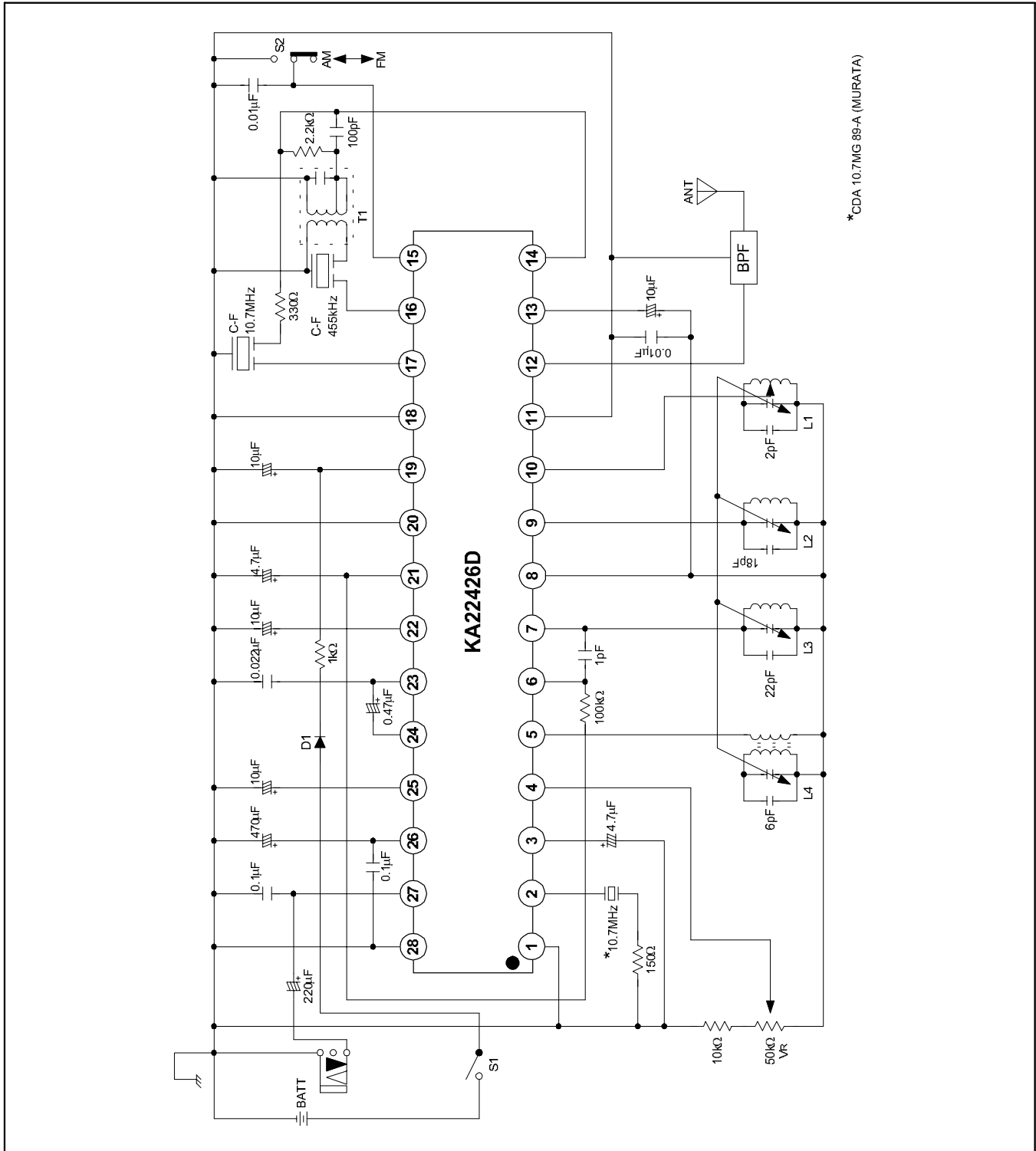

Figure 2.