

FM FRONT END FOR PORTABLE RADIO

The KA2249/D is a monolithic integrated circuit designed for FM front end of the portable radio.

FEATURES

- High frequency amplifier, frequency converter, local oscillator.
- Wide operating voltage: $V_{CC} = 2V \sim 7V$ (KA2249)
 $V_{CC} = 2V \sim 5V$ (KA2249D)
- Low current consumption: Typ. 2mA ($V_{CC} = 4V$).

7 SIP

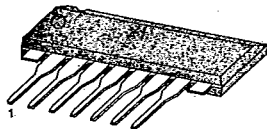

8 SOP

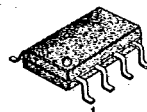

SCHEMATIC DIAGRAM

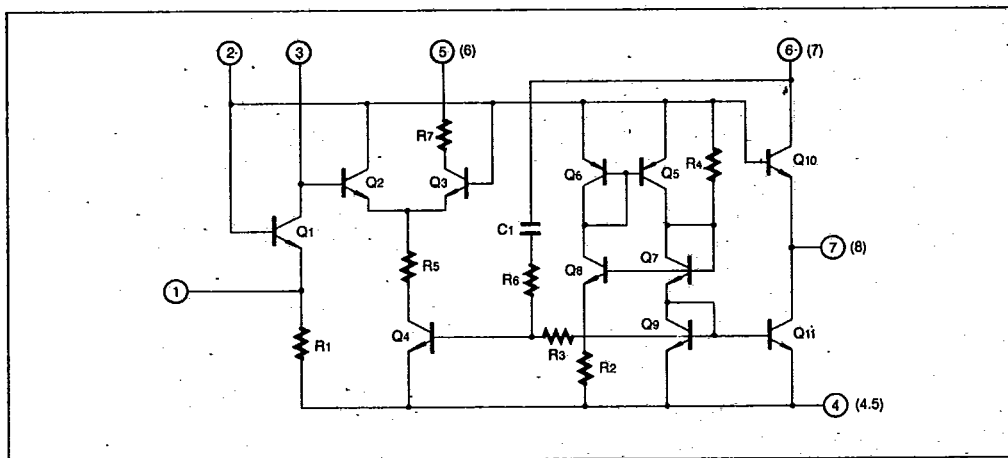

(): KA2249D

Fig. 1

ABSOLUTE MAXIMUM RATINGS ($T_a = 25^\circ\text{C}$)

Characteristic	Symbol	Value	Unit
Supply Voltage	V_{CC}	7	V
Terminal Voltage	$V(3\sim 4)$	14	V
	$V(5\sim 4)$		
	$V(6\sim 4)$		
Power Dissipation ($T_a = 75^\circ\text{C}$)	P_d	30	mW
Operating Temperature	T_{opr}	$-20 \sim +75$	$^\circ\text{C}$
Storage Temperature	T_{stg}	$-55 \sim +125$	$^\circ\text{C}$

ELECTRICAL CHARACTERISTICS

(Ta = 25°C; V_{CC} = 4V, unless otherwise specified)

Characteristic	Symbol	Test Conditions	Min	Typ	Max	Unit	Fig
Circuit Current	I_{CC}	$V_i = 0$	1.4		3.0	mA	2
Output Voltage	V_o	$V_i = 70\text{dB}\mu, 106\text{MHz}$	30.5		68.5	mV	3
Oscillation Voltage	V_{osc}	$V_{CC} = 2V$	130			mV	3

TEST CIRCUIT 1

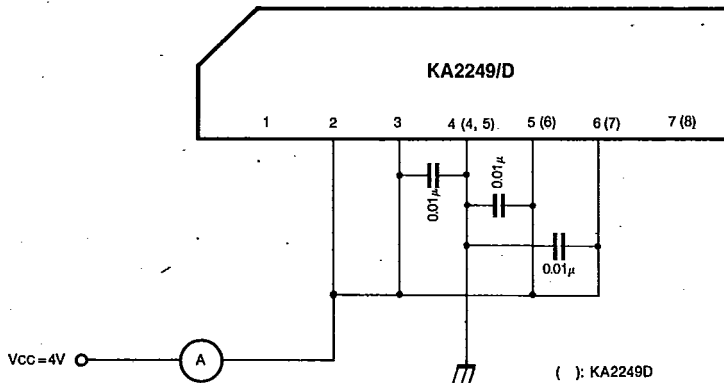

Fig. 2

TEST CIRCUIT 2 (V_o , V_{osc})

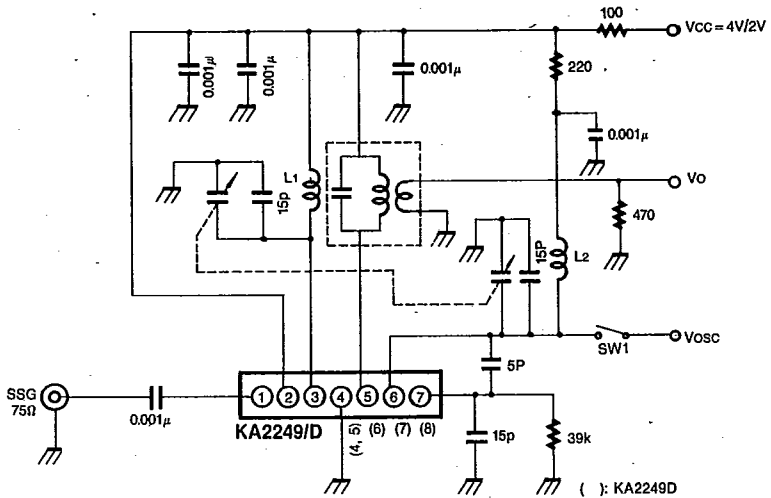
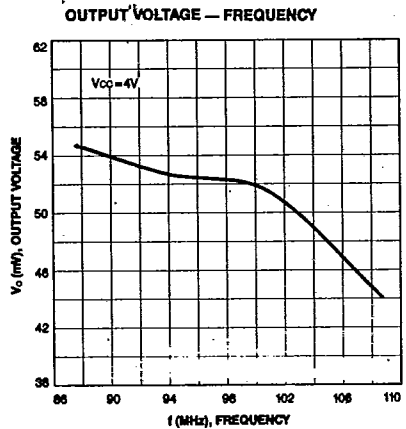
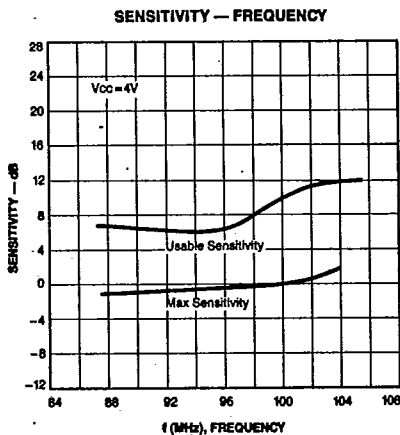
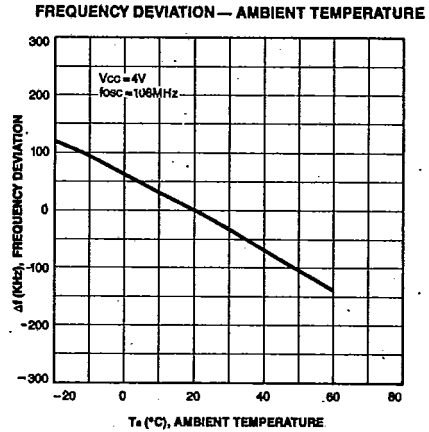
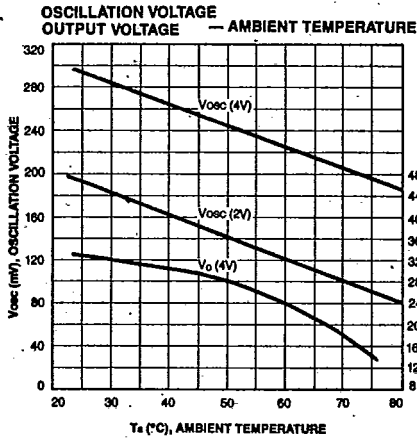
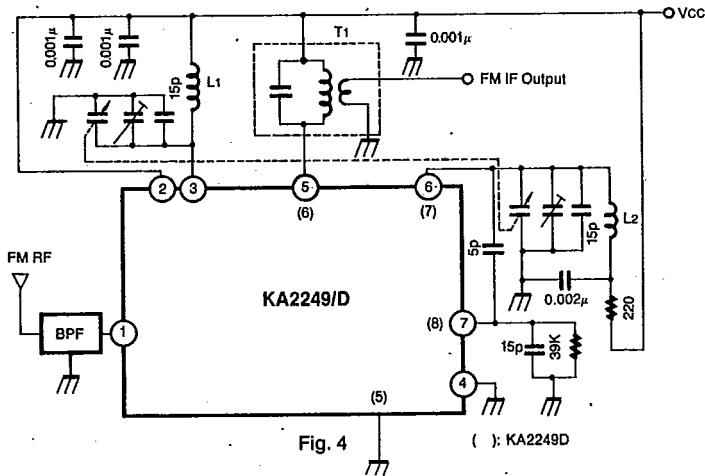

Fig. 3





APPLICATION CIRCUIT



COIL SPECIFICATION

T1 FM IFT

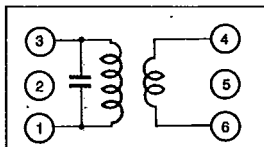

Co (pF)	f (MHz)	Qo (%)	TURNS	
			1-3	4-6
56	10.7	95	12	2

Seoul Jupa
SJ-015-382
0.1mmφ UEW