

KA3842/43/44/45

Current Mode PWM Controller

July 1995 - revised July 2002



DESCRIPTION

KA3842/43/44/45 are fixed frequency current mode PWM controller. They are specially designed for OFF-Line and DC to DC converter applications with a minimal external components. Internally implemented circuits include a trimmed oscillator for precise duty cycle control, a temperature compensated reference, high gain error amplifier, current sensing comparator, and a high current totem pole output ideally suited for driving a power MOSFET. Protection circuitry includes built undervoltage lockout and current limiting.

The UC3842A(AM) and UC3844A(AM) have UVLO thresholds of 16 V (on) and 10 V (off). The corresponding thresholds for the UC3843A(AM)/45A(AM) are 8.4V (on) and 7.6V (off). The UC3842A(AM) and UC3843A(AM) can operate within 100% duty cycle. The UC3844A(AM) and UC3845A(AM) can operate within 50% duty cycle. The UC384XA(AM) has Start-Up Current 0.17mA (typ).

PIN CONNECTION (TOP VIEW)

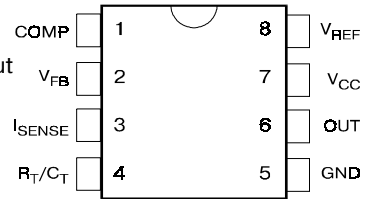

FEATURES

- Low Start-Up and Operating Current
- High Current Totem Pole Output
- Undervoltage Lockout With Hysteresis
- Operating Frequency Up To 300KHz (384XA)
500KHz (384XAM)

BLOCK DIAGRAM

(toggle flip flop used only in UC3844, UC3845)

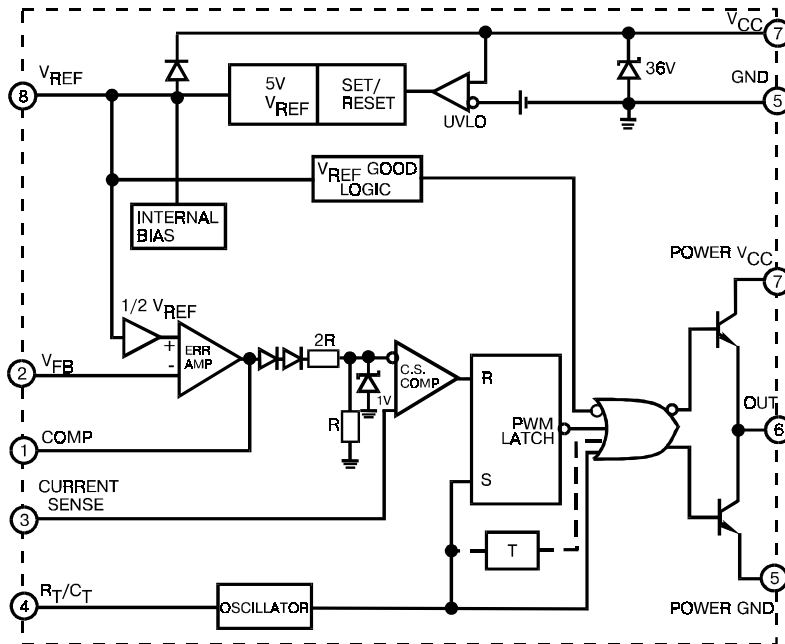

Absolute Maximum Ratings

Characteristic	Symbol	Value	Unit
Supply Voltage (low impedance source)	V_{CC}	30	V
Output Current	I_O	± 1	A
Input Voltage (Analog Inputs pins 2,3)	V_I	-0.3 to 5.5	V
Error Amp Output Sink Current	$I_{SINK (E.A.)}$	10	mA
Power Dissipation ($T_A=25^\circ C$)	P_O	1	W
Storage Temperature Range	T_{stg}	-65 to 150	$^\circ C$
Lead Temperature (soldering 5 sec.)	T_L	260	$^\circ C$



KA3842/43/44/45

Electrical characteristics (* $V_{CC}=15V$, $R_T=10k\Omega$, $C_T=3.3nF$, $T_A=0^\circ C$ to $+70^\circ C$, unless otherwise specified)

Characteristics	Symbol	Test Condition	Min	Typ	Max	Unit	
Reference Section							
Reference Output Voltage	V_{REF}	$T_J = 25^\circ C$, $I_{REF} = 1 \text{ mA}$	4.9	5.0	5.1	V	
Line Regulation	ΔV_{REF}	$12V \leq V_{CC} \leq 25 \text{ V}$		6.0	20	mV	
Load Regulation	ΔV_{REF}	$1 \text{ mA} \leq I_{REF} \leq 20 \text{ mA}$		6.0	25		
Short Circuit Output Current	I_{SC}	$T_A = 25^\circ C$		-100	-180	mA	
Oscillator Section							
Oscillation Frequency	f	$T_J = 25^\circ C$	384XA	47	50	57	KHz
			384XAM	47	52	57	
Frequency Change with Voltage	$\Delta f/\Delta V_{CC}$	$12V \leq V_{CC} \leq 25 \text{ V}$		0.05	1.0	%	
Oscillator Amplitude	$V_{(OSC)}$	(peak to peak)		1.6		V	
Error Amplifier Section							
Input Bias Current	I_{BIAS}	$V_{FB}=3V$		-0.1	-2	μA	
Input Voltage	$V_{I(EA)}$	$V_{pin1} = 2.5V$	2.42	2.5	2.58	V	
Open Loop Voltage Gain	A_{VOL}	$2V \leq V_0 \leq 4V$	65	90		dB	
Power Supply Rejection Ratio	PSRR	$12V \leq V_{CC} \leq 25 \text{ V}$	60	70			
Output Sink Current	I_{SINK}	$V_{pin2} = 2.7V$, $V_{pin1} = 1.1V$	2	7		mA	
Output Source Current	I_{SOURCE}	$V_{pin2} = 2.3V$, $V_{pin1} = 5V$	-0.5	-1.0		mA	
High Output Voltage	V_{OH}	$V_{pin2} = 2.3V$, $R_L = 15K\Omega$ to GND	5.0	6.0		V	
Low Output Voltage	V_{OL}	$V_{pin2} = 2.7V$, $R_L = 15K\Omega$ to PIN 8		0.8	1.1		
Current Sense Section							
Gain	G_V	(Note 1 & 2)	2.85	3.0	3.15	V/V	
Maximum Input Signal	$V_{I(MAX)}$	$V_{pin1} = 5V$ (Note 1)	0.9	1.0	1.1	V	
Supply Voltage Rejection	SVR	$12V \leq V_{CC} \leq 25 \text{ V}$ (Note 1)		70		dB	
Input Bias Current	I_{BIAS}	$V_{pin3} = 3V$		-3.0	-10	μA	
Output Section							
Low Output Voltage	V_{OL}	$I_{SINK} = 20 \text{ mA}$		0.08	0.4	V	
		$I_{SINK} = 200 \text{ mA}$		1.4	2.2		
High Output Voltage	V_{OH}	$I_{SINK} = 20 \text{ mA}$	13	13.5			
		$I_{SINK} = 200 \text{ mA}$	12	13.0			
Rise Time	t_R	$T_J = 25^\circ C$, $C_L = 1nF$ (Note 3)		45	150	nS	
Fall Time	t_F	$T_J = 25^\circ C$, $C_L = 1nF$ (Note 3)		35	150		
Undervoltage Lockout Section							
Start Theshold	$V_{TH(ST)}$	UC3842A(AM)/44A(AM)	14.5	16.0	17.5	V	
		UC3843A(AM)/45A(AM)	7.8	8.4	9.0		
Min. Operating Voltage (After Turn On)	$V_{OPR(min)}$	UC3842A(AM)/44A(AM)	8.5	10	11.5	V	
		UC3843A(AM)/45A(AM)	7.0	7.6	8.2		
PWM Section							
Max. Duty Cycle	$D_{(MAX)}$	UC3842A(AM)/43A(AM)	95	97	100	%	
		UC3844A(AM)/45A(AM)	47	48	50		
Min. Duty Cycle	$D_{(MAX)}$			0			
Total Standby Current							
Start-Up Current	I_{ST}	UC384XA(AM)		0.17	0.3	mA	
Operating Supply Current	$I_{CC(OPR)}$	$V_{pin3} = V_{pin2} = 0V$		13	17		
Zener Voltage	V_Z	$I_{CC}=25 \text{ mA}$	30	38		V	

* Adjust V_{CC} above the start threshold before setting it to 15V.

Note 1: Parameter measured at trip point of latch with $V_{pin2}=0$.

Note 2: Gain defined as $A=\Delta V_{pin1}/\Delta V_{pin3}$; $0 \leq V_{pin3} \leq 0.8V$.

Note 3: These parameters, although guaranteed, are not 100% tested in production.



PIN FUNCTION

N	FUNCTION	DESCRIPTION
1	COMP	This pin is the Error Amplifier output and is made for loop compensation.
2	V _{FB}	This is the inverting input of the Error Amplifier. It is normally connected to the switching power supply output through a resistor divider.
3	I _{SENSE}	A voltage proportional to inductor current is connected to this input. The PWM uses this information to terminate the output switch conduction.
4	R _T /C _T	The oscillator frequency and maximum Output duty cycle are programmed by connecting resistor R _T to V _{ref} and capacitor C _T to ground.
5	GROUND	This pin is the combined control circuitry and power ground.
6	OUTPUT	This output directly drives the gate of a power MOSFET. Peak currents up to 1A are sourced and sink by this pin.
7	V _{CC}	This pin is the positive supply of the integrated circuit.
8	V _{ref}	This is the reference output. It provides charging current for capacitor C _T through resistor R _T .

APPLICATION INFORMATION

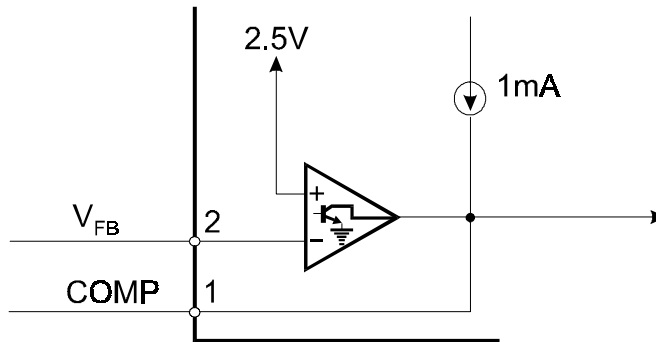

Figure 1. Error Amp Configuration

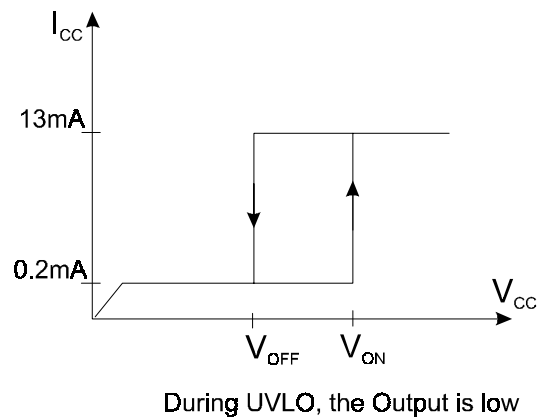
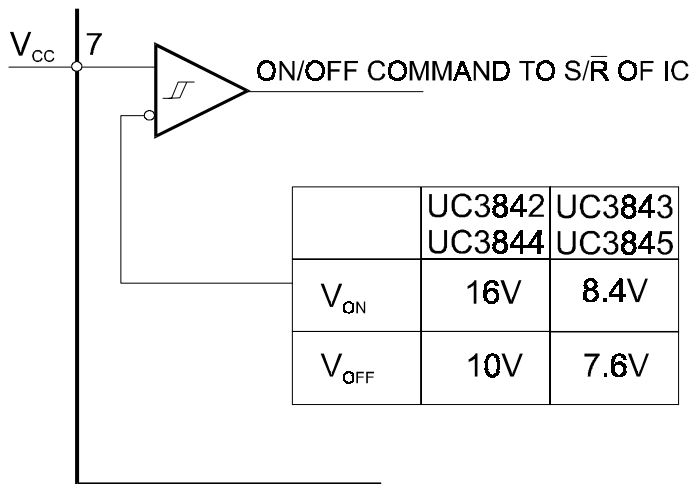
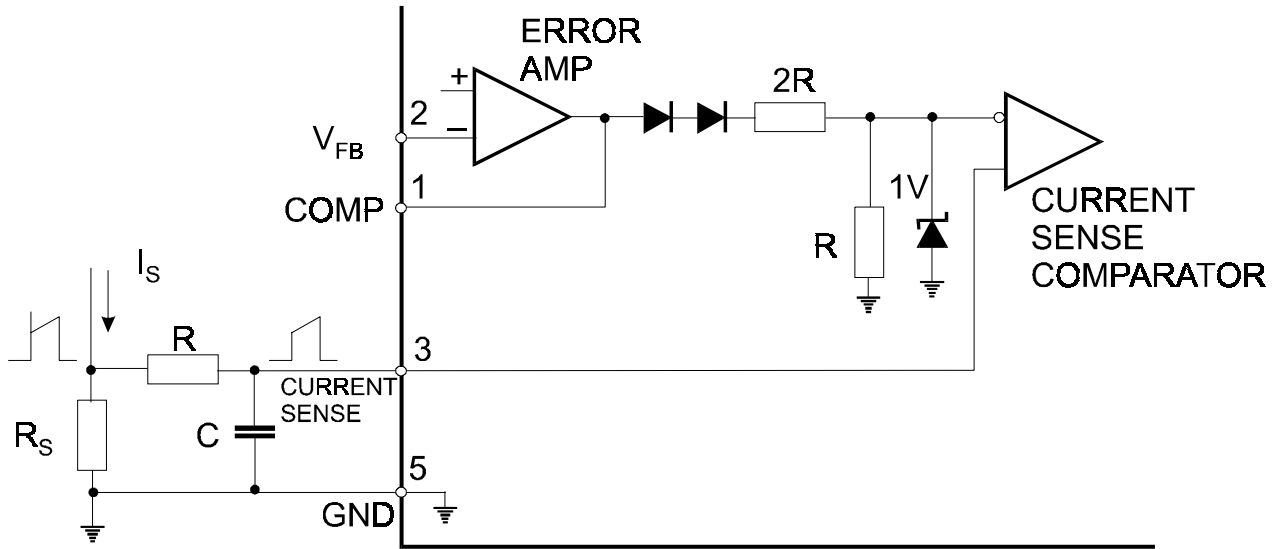

Figure 2. Undervoltage Lockout

KA3842/43/44/45



Peak current is determined by $I_{S \max} \approx \frac{1.0V}{R_S}$

Figure 3. Current Sense Circuit

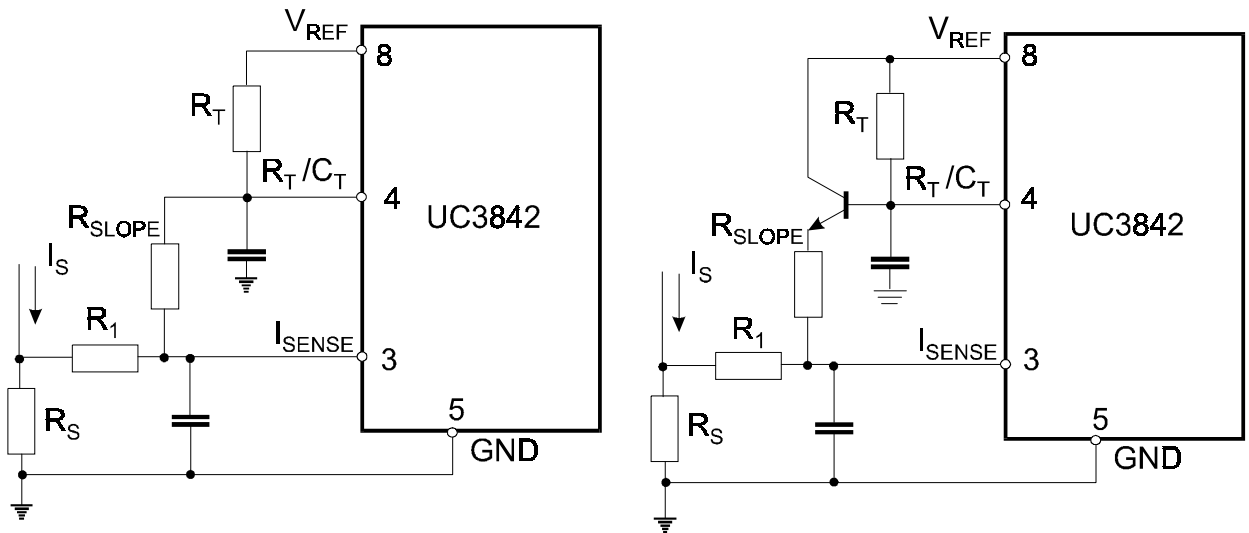
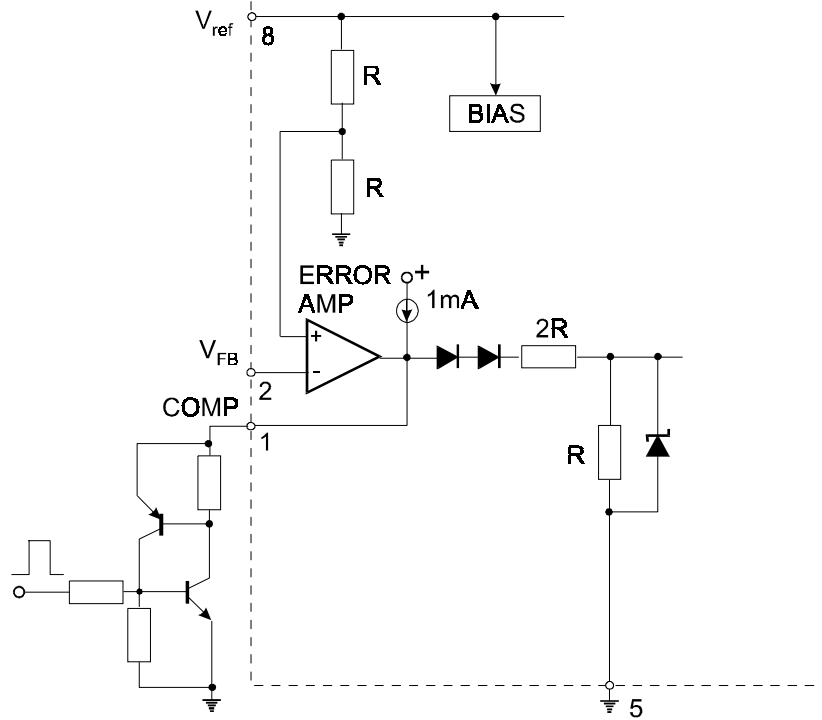
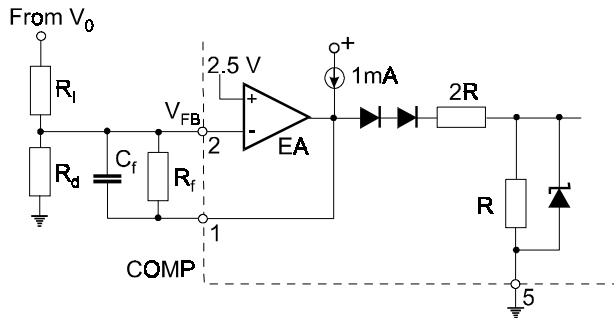

Figure 4. Slope Compensation Techniques



SCR must be selected for a holding current of less than 0.5mA.
 The simple two transistor circuit can be used in place of the SCR as shown.

Figure 5. Latched Shutdown



Error Amp compensation circuit for stabilizing any current-mode topology except for boost and flyback converters operating with continuous inductor current.

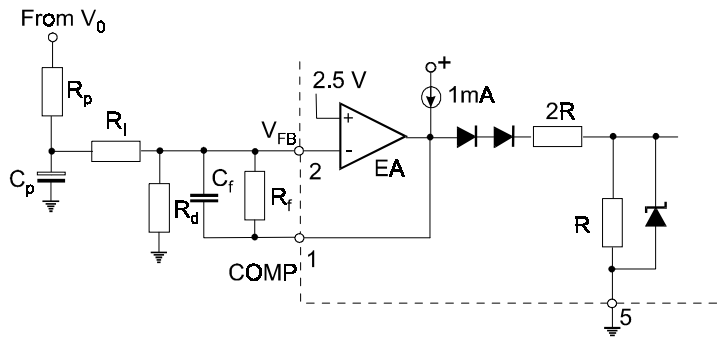

Error Amp compensation circuit for stabilizing current-mode boost and flyback topologies operating with continuous inductor current.

Figure 6. Error Amplifier Compensation

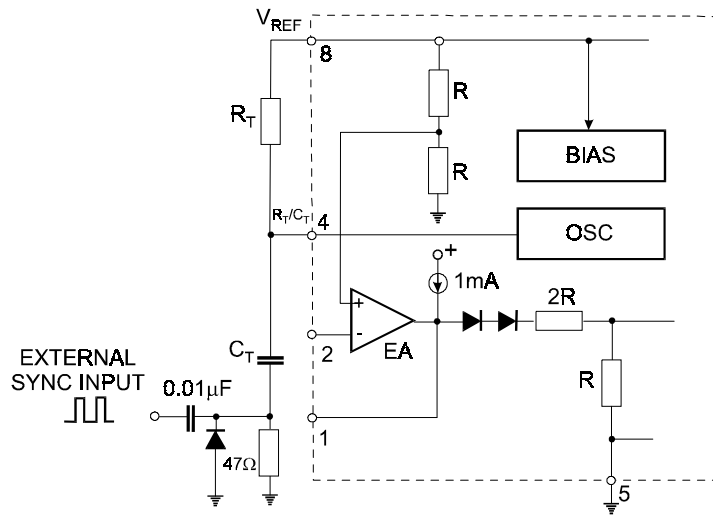

Figure 7. External Clock Synchronization

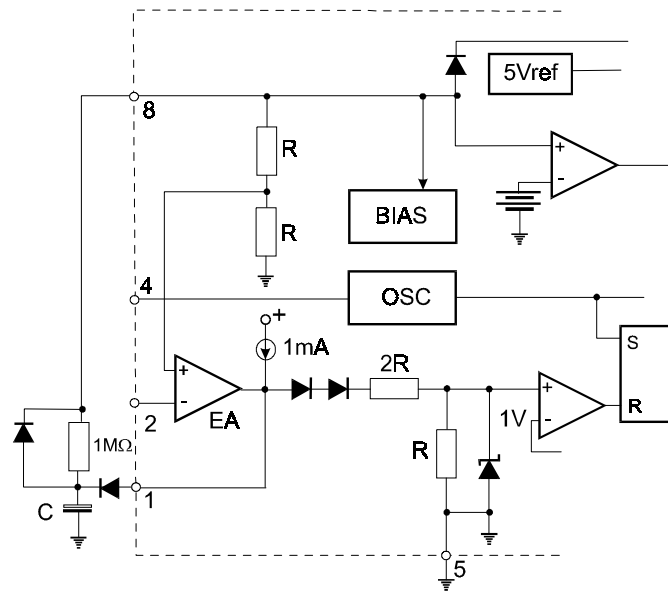

Figure 8. Soft-Start Circuit



KA3842/43/44/45

TYPICAL PERFORMANCE CHARACTERISTICS

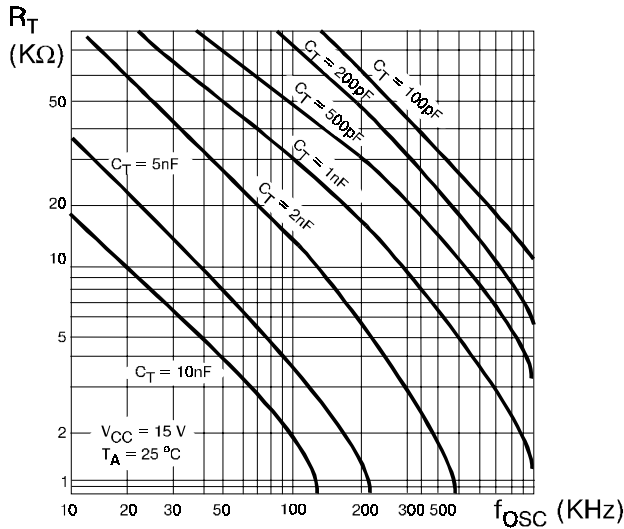

Figure 1. Timing Resistor vs. Oscillator Frequency

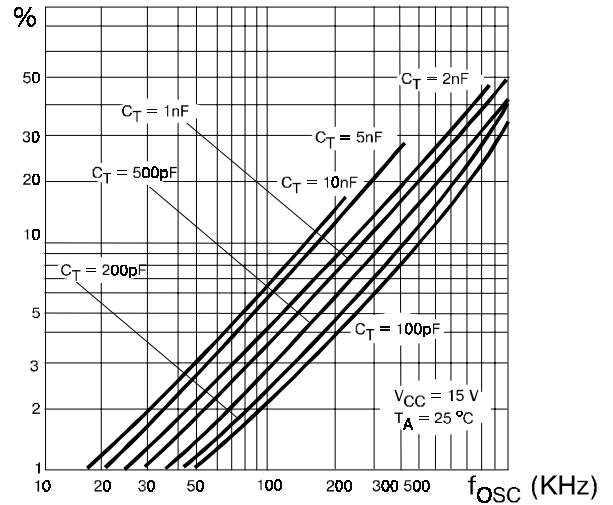

Figure 2. Output Dead-Time vs. Oscillator Frequency

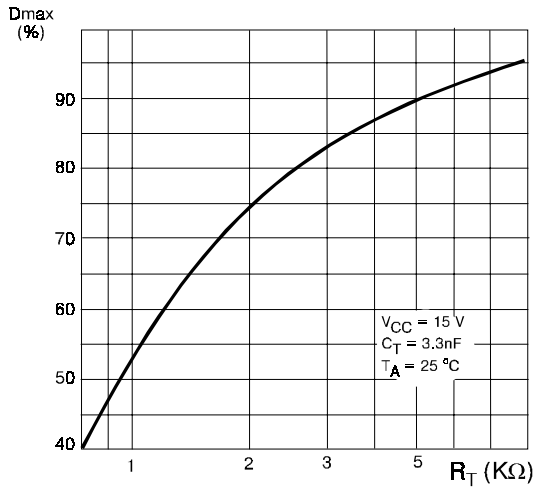

Figure 3. Maximum Output Duty Cycle vs. Timing Resistor (UC3842/43)

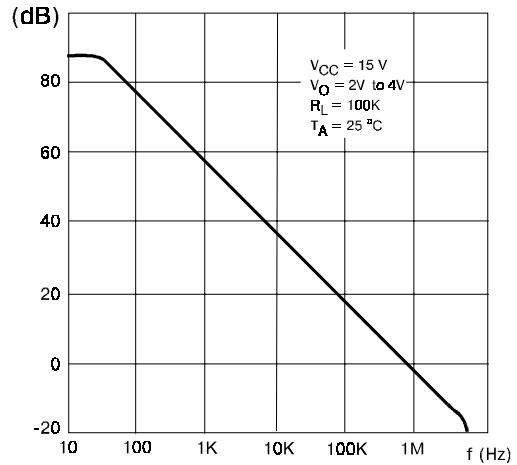

Figure 4. Error Amp Open-Loop Gain vs. Frequency

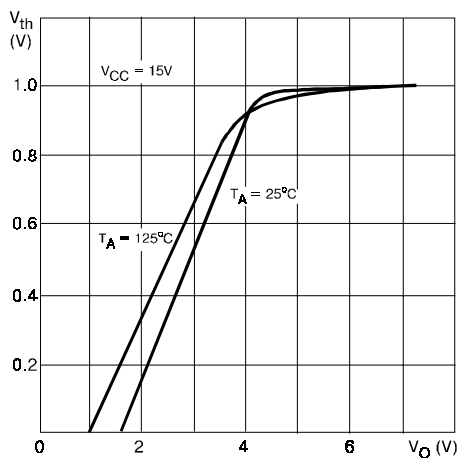

Figure 5. Current Sense Input Threshold vs. Error Amp Output Voltage

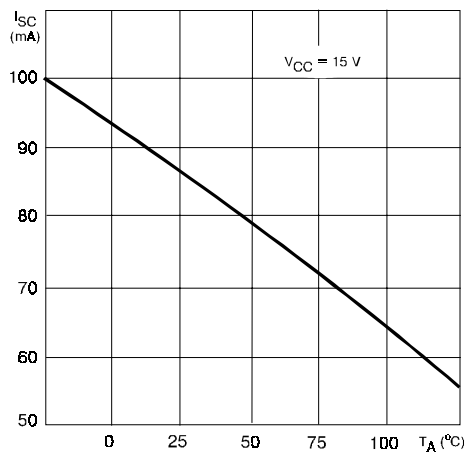

Figure 6. Reference Short Circuit Current vs. Temperature

KA3842/43/44/45

Current Mode PWM Controller

July 1995 - revised July 2002

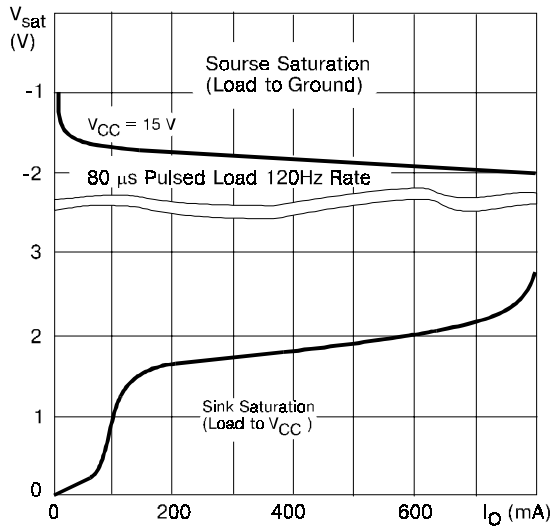

Figure 7. Output Saturation Voltage vs. Load Current
 $T_A = 25^\circ\text{C}$

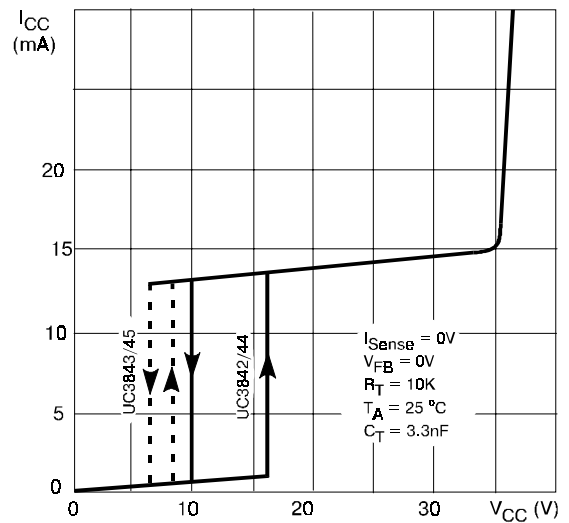

Figure 8. Supply Current vs. Supply Voltage

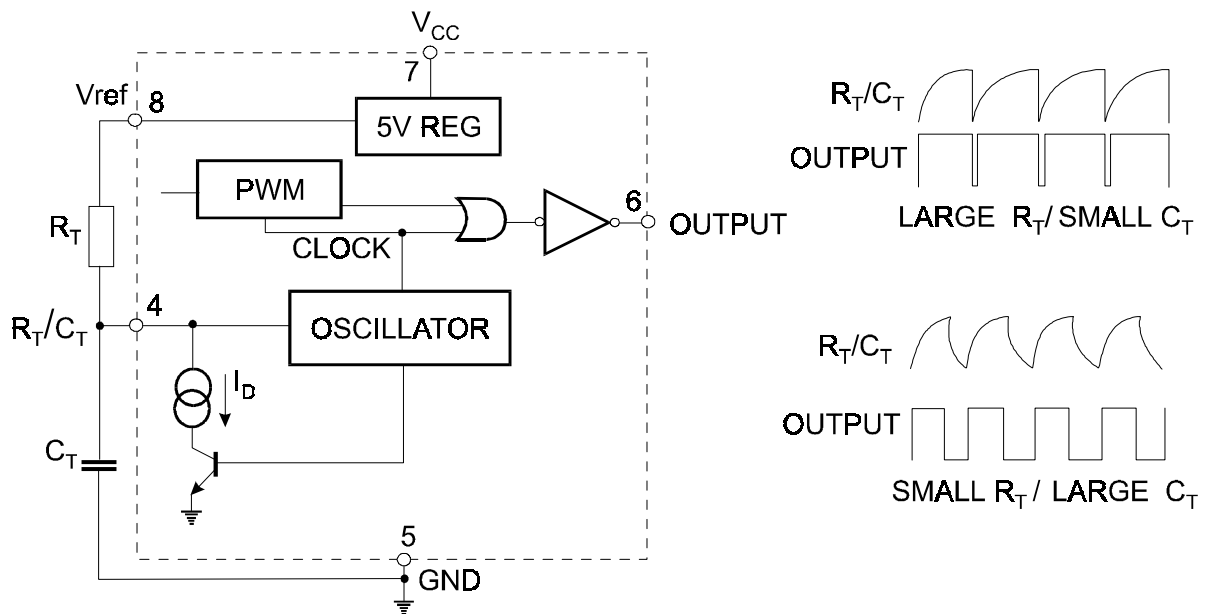
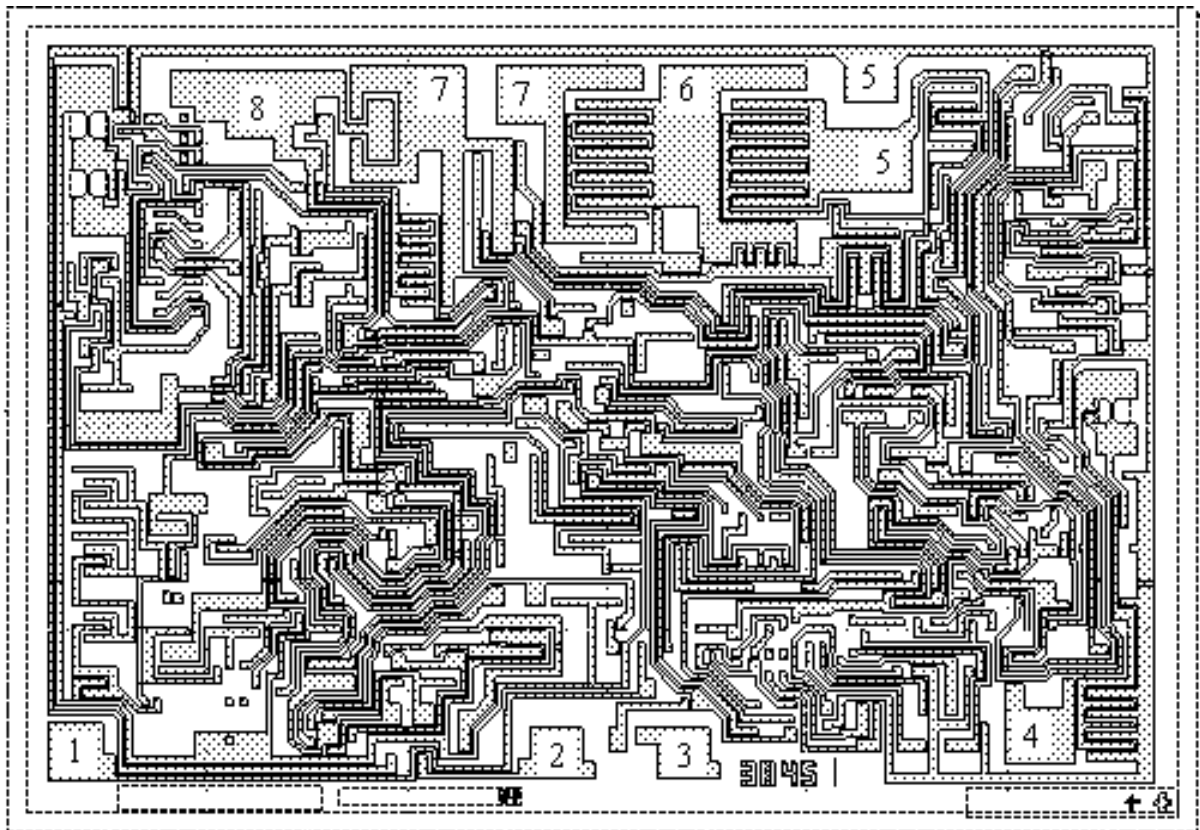

Figure 9. Oscillator and Output Waveforms



PAD LOCATION



Chip size: 2.38 x 1.63 mm

Pad N	Pad Name	Coordinates μm	
		X	Y
1	COMP	90	110
2	V_{FB}	1050	110
3	I_{SENSE}	1310	110
4	$R_{\text{T}}/C_{\text{T}}$	2000	150
5	POWER GND	1700	1280
6	GND	1680	1450
7	OUT	1310	1410
8	POWER V_{CC}	990	1410
9	V_{CC}	815	1410
10	V_{REF}	460	1390