

KA7526

Power Factor Correction Controller

Features

- Internal Startup Timer
- Internal R/C filter which eliminates the Need for an External R/C filter
- Overvoltage Comparator eliminates Runaway Output Voltage
- Zero Current Detector
- One Quadrant Multiplier
- Trimmed 1.5% Internal Bandgap Reference
- Under Voltage Lock Out with 5V of Hysteresis
- Totem Pole Output with High State Clamp
- Low Startup and Operating Current
- 8-Pin DIP or 8-Pin SOP

Applications

- Electronic Ballast
- SMPS

Descriptions

The KA7526 provides simple and high performance active power factor correction. KA7526 is optimized for electronic ballast and low power, high density power supplies requiring a minimum board area, reduced component count and low power dissipation. Addition of internal R/C filter eliminates the need for an external R/C filter. Internal clamping of the error amplifier and multiplier outputs improves turn on overshoot characteristics and current limiting. Special circuitry has also been added to prevent no load runaway conditions. The output drive clamping circuit limits overshoot of the power MOSFET gate drive Independent of supply voltage, so that it greatly enhance the system reliability.

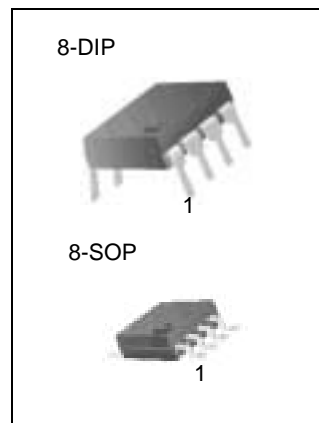

Internal Block Diagram

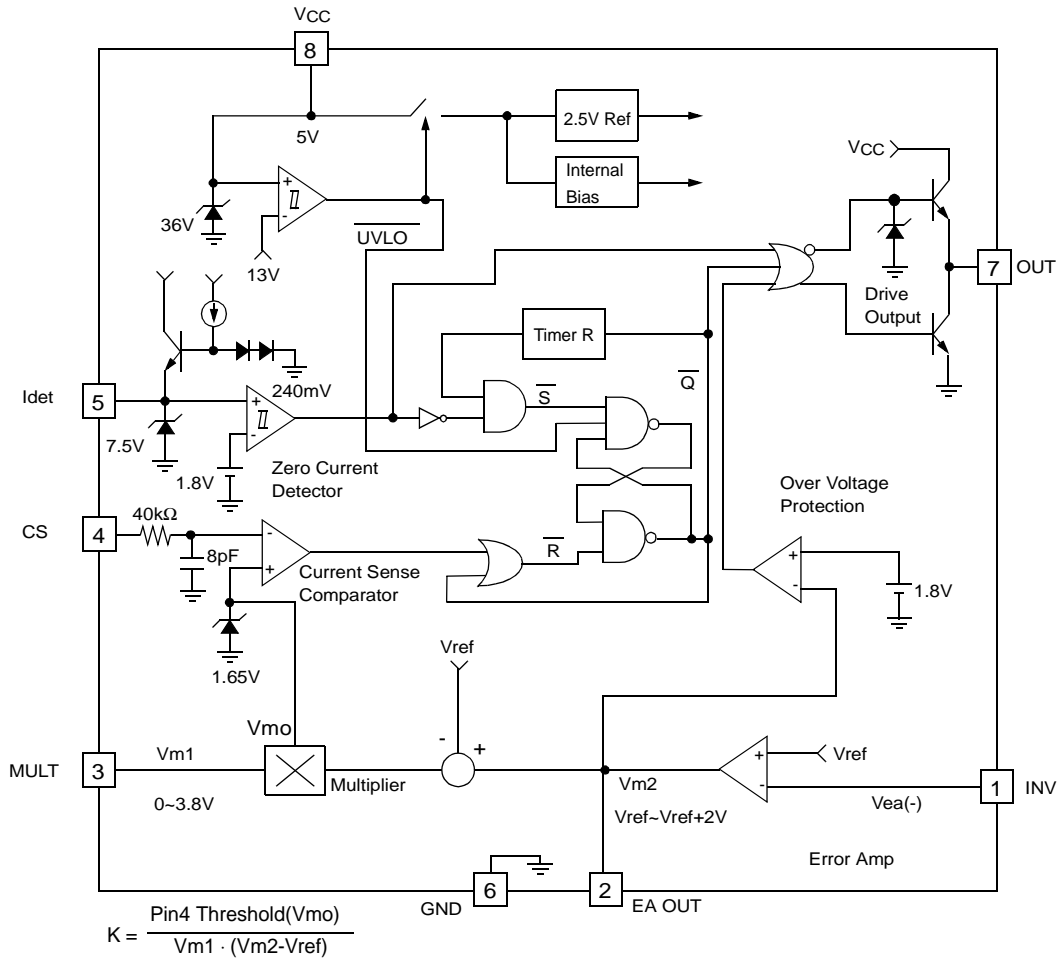

IC Characteristics

Parameter	KA7526
UVLO	8/13V
Multiplier Input Range (Vm1)	0 ~ 3.8V
Multiplier Input Range (Vm2)	Vref ~ Verf + 2V
Maximum Current Sense Voltage	1.65V

PIN Assignments

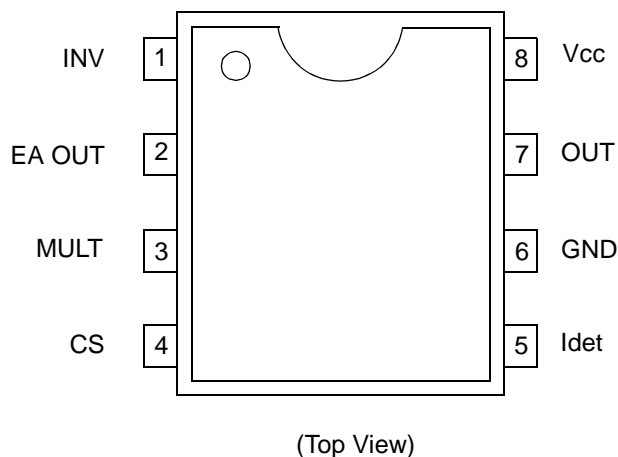

Pin Definitions

Pin Number	Pin Name	Pin Function Description
1	INV	Inverting input of the error amplifier. The output of the boost converter should be resistively divided to 2.5V and connected to this pin.
2	EA OUT	The output of the error amplifier. A feedback compensation network is placed between this pin and the INV pin
3	MULT	Input to the multiplier stage. The full-wave rectified AC is divided to less than 3.8V and is connected to this pin.
4	CS	Input to the PWM comparator. The Current is sensed in the boost stage by a resistor in the source lead of MOSFET. An internal leading edge blanking circuitry has been included to reject any high frequency noise present on the current waveform.
5	Idet	The zero current detector senses the inductor current by monitoring when the boost inductor auxiliary winding voltage falls below 1.8V.
6	GND	The ground potential of all the pins.
7	OUT	The output of a high-current power driver capable of driving the gate of a power MOSFET.
8	VCC	The logic and control power supply connection.

Absolute Maximum Ratings

Parameter	Symbol	Value	Unit
Supply voltage	V _{CC}	30	V
Peak drive output current	I _{OH} , I _{OI}	± 500	mA
Driver output clamping diodes V _O >V _{CC} or V _O <-0.3V	I _{clamp}	± 10	mA
Detector clamping diodes	I _{det}	± 3	mA
Error amp, multiplier and comparator input voltage	V _{IN}	-0.3 to 6	V
Operating temperature range	T _{opr}	-25 to 125	°C
Storage temperature range	T _{stg}	-65 to 150	°C
Power dissipation ^(Note)	P _d	0.8	W
Thermal resistance ^(Note) (Junction-to-air)	q _{ja}	100	°C/W

Note :

Based in 8-DIP

Temperature Characteristics (-25°C ≤ Ta ≤ 125°C)

Parameter	Symbol	Value	Unit
Temperature stability for reference voltage(V _{ref})	ΔV _{ref} (Typ)	20	mV
Temperature stability for multiplier gain(K)	ΔK/ΔT (Typ)	-0.2	%/°C

Electrical Characteristics

Unless otherwise specified, for typical values $V_{CC}=12V$, $T_a=25^{\circ}C$, for Min/Max values T_a is the operating ambient temperature range with $-25^{\circ}C \leq T_a \leq 125^{\circ}C$.

Parameter	Symbol	Condition	Min.	Typ.	Max.	Unit
UNDER VOLTAGE LOCK OUT SECTION						
Start Threshold Voltage	$V_{th(st)}$	V_{CC} Increasing	12	13	14	V
UVLO Hysteresis	$HY(st)$	-	4	5	6	V
Supply Zener Voltage	V_z	$I_{CC}=10mA$	30	36	-	V
SUPPLY CURRENT SECTION						
Start Up Supply Current	I_{st}	$V_{CC} < V_{th(st)}$	-	0.3	0.4	mA
Operating Supply Current	I_{CC}	Output not switching	-	4	8	mA
Dynamic Operating Supply Current	I_{dCC}	50kHz, $C_I=1nF$	-	5	10	mA
ERROR AMPLIFIER SECTION						
Voltage Feedback Input Threshold	V_{ref}	$I_{ref}=0mA$, $-25^{\circ}C \leq T_a \leq 125^{\circ}C$	2.44	-	2.56	V
Line Regulation	ΔV_{ref1}	$12V \leq V_{CC} \leq 25V$	-	0.1	10	mV
Load Regulation ^(Note1)	ΔV_{ref2}	$0mA \leq I_{ref} \leq 2mA$	-	0.1	10	mV
Temperature Stability of V_{ref} ^(Note2)	ΔV_{ref3}	$-25^{\circ}C \leq T_a \leq 125^{\circ}C$	-	20	-	mV
Input Bias Current	$I_{b(ea)}$	-	-0.5	-	0.5	μA
Output Source Current	I_{source}	$V_{m2}=3V$	-2	-4.5	-	mA
Output Sink Current	I_{sink}	$V_{m2}=2V$	3	4.5	-	mA
Output Voltage Range ^(Note2)	ΔV_{eao}	No Load on E.A Output	1.2	-	5.6	V
Slew Rate	SR	-	-	0.6	-	V/ μs
MULTIPLIER SECTION						
Input Bias Current (pin3)	$I_{b(m)}$	-	-0.5	-	0.5	μA
M1 Input Voltage Range (pin3)	ΔV_{m1}	-	0	-	3.8	V
M2 Input Voltage Range (pin2)	ΔV_{m2}	-	V_{ref}	-	$V_{ref}+2$	V
Multiplier Gain ^(Note3)	K	$V_{m1}=1V$, $\Delta V_{m2}=2.7$ to $3.3V$	0.49	0.62	0.74	1/V
Maximum Multiplier Output Voltage	$V_{omax(m)}$	$V_{ea(-)}=0V$, $V_{m1}=2V$	1.55	1.65	1.75	V
Temperature Stability of K ^(Note2)	$\Delta K/\Delta T$	$-25^{\circ}C \leq T_a \leq 125^{\circ}C$	-	-0.2	-	%/ $^{\circ}C$

Electrical Characteristics (Continued)

Parameter	Symbol	Condition	Min.	Typ.	Max.	Unit
CURRENT SENSE SECTION						
Input Offset Voltage ^(Note2)	V _{io(cs)}	V _{m1} =0V, V _{m2} =2.2V	-10	3	10	mV
Input Bias Current	I _{b(cs)}	0V ≤ V _{CC} ≤ 1.7V	-1	-0.3	1	μA
Current Sense Delay to Output ^(Note2)	t _{d(cs)}	-	-	200	500	ns
DETECT SECTION						
Detect Input Threshold	V _{th(det)}	V _{det} Increasing	1.5	1.8	2.1	V
Detect Hysteresis	H _{Y(det)}	-	180	240	400	mV
Input Low Clamp Voltage	V _{clamp(l)}	I _{det} = -100μA	0.45	0.75	1	V
Input High Clamp Voltage	V _{clamp(h)}	I _{det} = 3mA	6.7	7.5	8.3	V
Input Bias Current	I _{b(det)}	1V ≤ V _{det} ≤ 6V	-1	-0.2	1	μA
Input High/low Clamp Diode Current ^(Note2)	I _{clamp}	-	-	-	± 3	mA
OUTPUT DRIVER SECTION						
Output Voltage High	V _{OH}	I _O = -10mA, V _{CC} = 12V	8.5	9	-	V
Output Voltage Low	V _{OL}	I _O = 10mA, V _{CC} = 12V	-	0.8	1	V
Rising Time ^(Note2)	t _r	C _I = 1nF	-	130	200	ns
Falling Time ^(Note2)	t _f	C _I = 1nF	-	50	120	ns
Maximum Output Voltage	V _{omax(o)}	V _{CC} = 20V	12	13	15	V
Output Voltage With U _{vlo} Activated	V _{omin(o)}	V _{CC} = 5V, I _O = 100μA	-	-	1	V
RESTART TIMER SECTION						
Restart Time Delay	t _{d(rst)}	V _{m1} = 1V, V _{m2} = 3.5V	-	300	-	μs
OVERVOLTAGE PROTECTION SECTION						
Voltage Feedback Input Threshold	V _{th(ovp)}	V _{cs} = -0.5V, V _{m1} = 1V V _{det} = 0V	1.7	1.8	1.9	V

Notes :

1. Because the reference is not brought out externally, this specification cannot be tested on the package part. It is guaranteed by design.
2. This parameter, although guaranteed, is not tested in production.

$$3. K = \frac{\text{Pin4 Threshold}}{V_{m1} \times (V_{m2} - V_{ref})} \quad (V_{m1} = V_{pin3}, V_{m2} = V_{pin2})$$

Typical Performance Characteristics

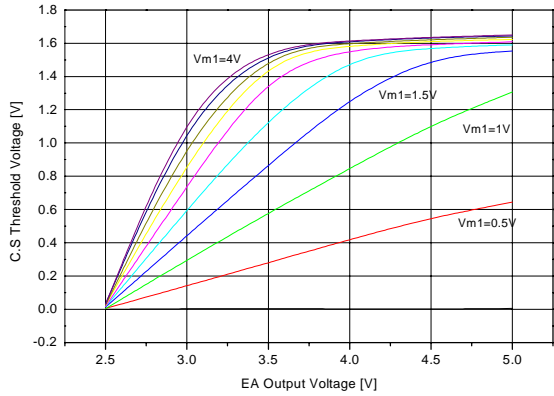

Figure 1. EA Output Voltage vs C.S. Threshold

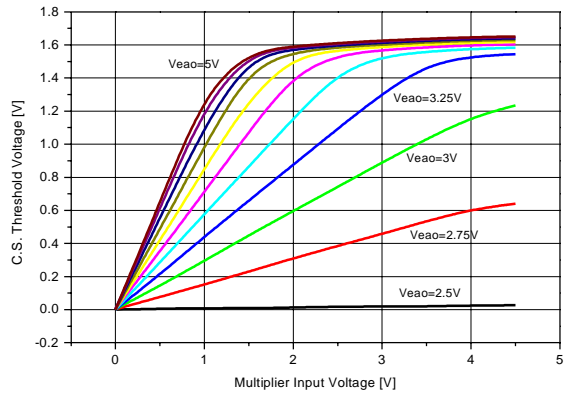

Figure 2. Multiplier Input Voltage vs C.S. Threshold

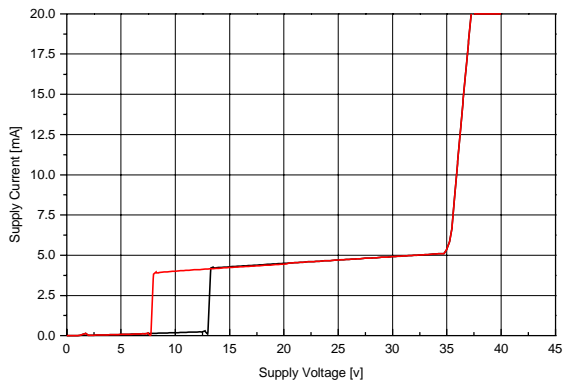

Figure 3. Supply Current vs Supply Voltage

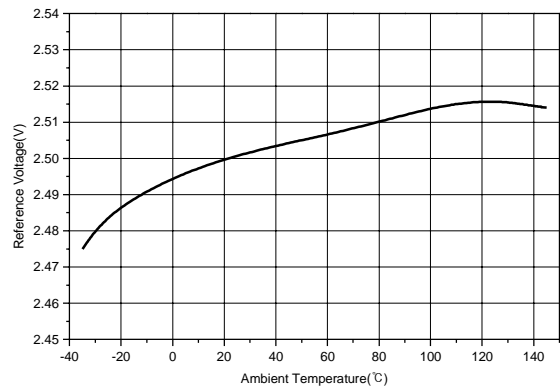

Figure 4. Reference Voltage vs Temperature

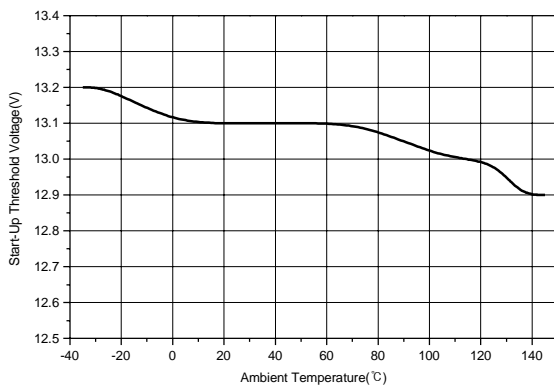

Figure 5. Start-Up Threshold vs Temperature

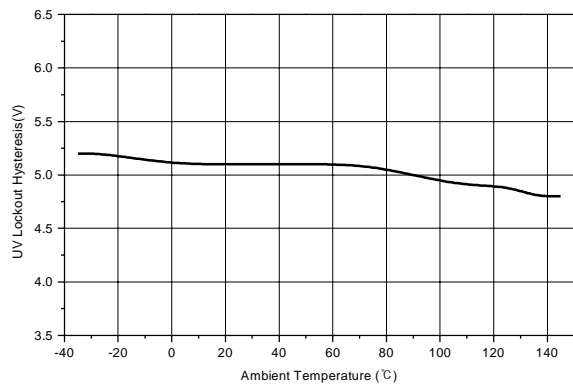

Figure 6. UV Lockout Hysteresis vs Temperature

Typical Performance Characteristics (continued)

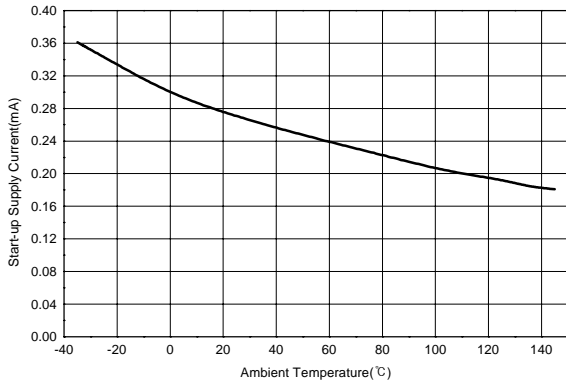

Figure 7. Start-Up Supply Current vs Temperature

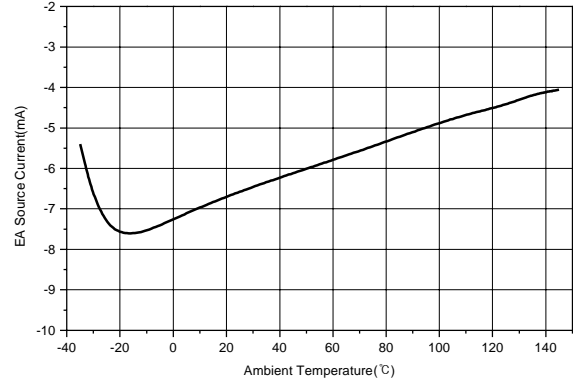

Figure 8. EA Source Current vs Temperature

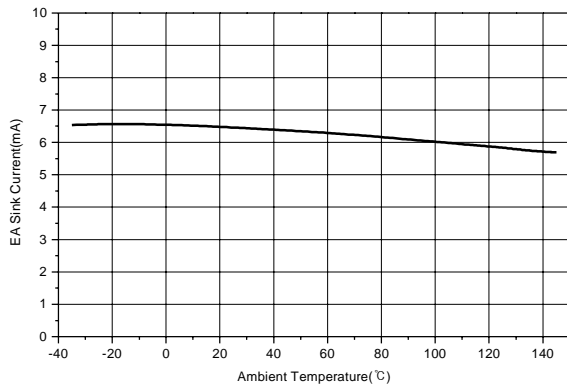

Figure 9. EA Sink Current vs Temperature

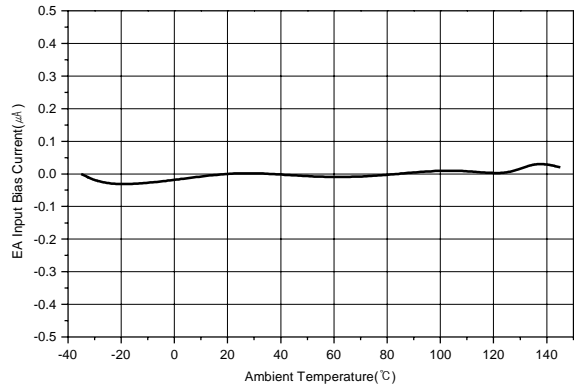

Figure 10. EA Input Bias Current vs Temperature

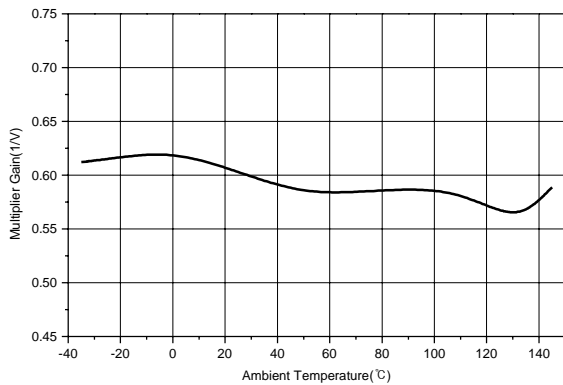

Figure 11. Multiplier Gain vs Temperature

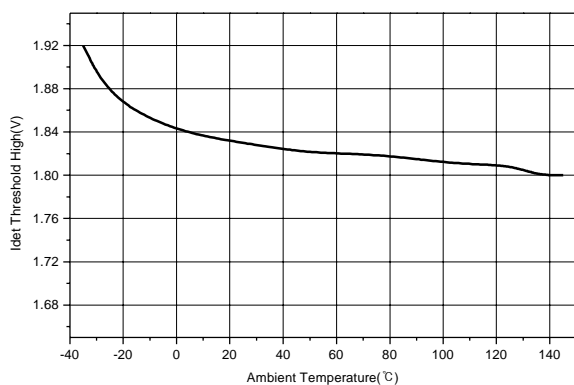

Figure 12. Idet Threshold Voltage vs Temperature

Typical Performance Characteristics (continued)

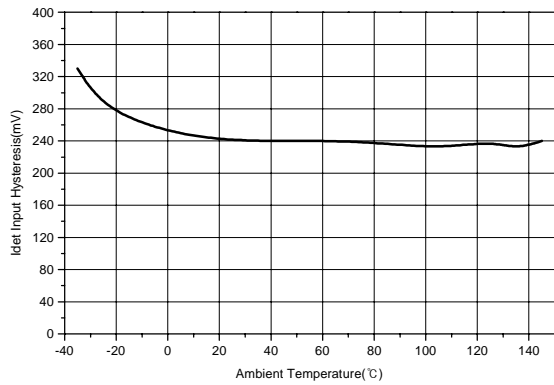

Figure 13. Idet Input Hysteresis vs Temperature

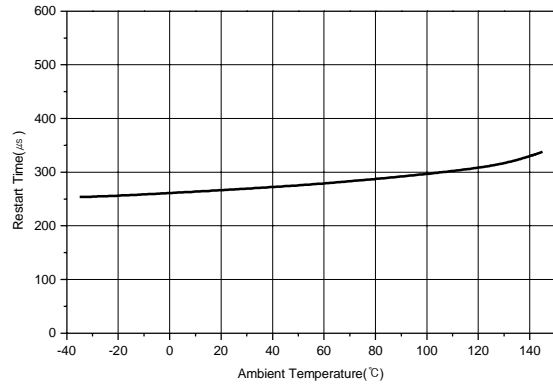

Figure 14. Restart Time vs Temperature

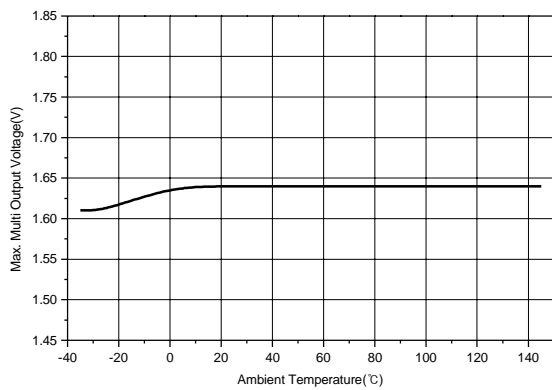

Figure 15. Max. Mult. Output Voltage vs Temperature

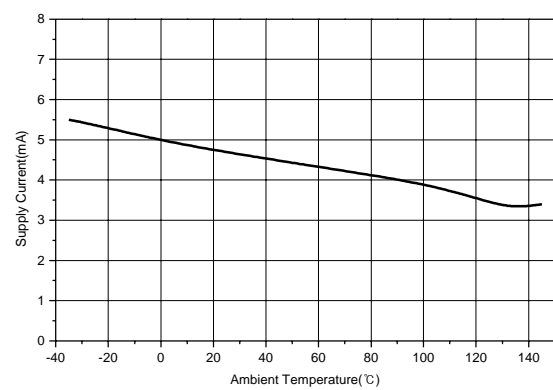

Figure 16. Supply Current vs Temperature

Operating Description

KA7526 is high performance, critical conduction, current-mode power factor controller specifically designed for use in off-line active preconverters with minimal external components. This device provides the necessary features which are required to significantly enhance poor power factor loads by keeping the ac line current sinusoidal and in phase with the line voltage.

KA7526 contains many of the building blocks and protection features that are employed in modern high performance current mode power supply controllers. A description of each of the function blocks is given below.

START-UP

An Undervoltage Lockout comparator has been incorporated to guarantee that IC is fully functional before enabling the output stage. The positive power supply terminal (Vcc) is monitored by the UVLO comparator with the upper threshold set at 13V and the lower threshold at 8V. In the stand-by mode, with Vcc at 12.5V, the required supply current is less than 0.3mA. This large hysteresis and low start-up current allow the implementation of efficient bootstrap start-up techniques, making this device ideally suited for wide range off-line preconverter applications.

Fig.1.1 shows the start-up circuit. Circuit operation is as follows:

The start-up capacitor (Cst) is charged by current through start-up resistor (Rst) minus the start-up current drawn by the IC. Once the capacitor voltage reaches the start-up threshold, the IC turns on, starting the switching of the MOSFET. The operation of the IC demands an increase in operating current which results in discharging the capacitor. Before the start-up capacitor voltage is discharged below hysteresis voltage, the auxiliary winding voltage takes over as the supply voltage as shown in Fig. 1.2.

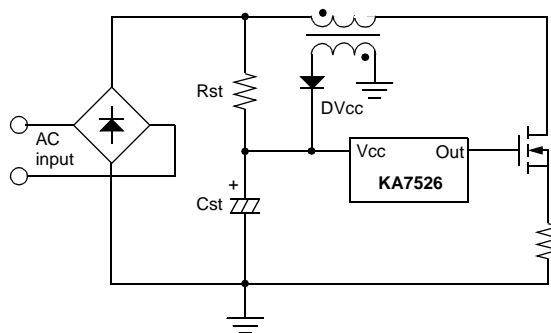

Fig.1.1 Start-up Circuit

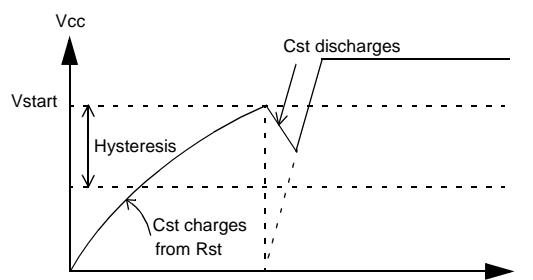

Fig.1.2 Start-up Capacitor Voltage

Error Amplifier

An Error Amplifier with access to the inverting input and output is provided. The noninverting input is internally biased at 2.5V and is not pinned out. The output voltage of the power factor converter is typically divided down and monitored by the inverting input. The error amp output is internally connected to the multiplier and is pinned out for external loop compensation. Typically, the loop bandwidth is set below 20Hz, so that the amplifier's output voltage is relatively constant over a given ac line cycle. In effect, the error amp monitors the average output voltage of the converter over several line cycles. Input bias current (0.5uA, max) can cause an output voltage error that is equal to the product of the input bias current and the value of the upper divider resistor, R1 in Fig. 2.1.

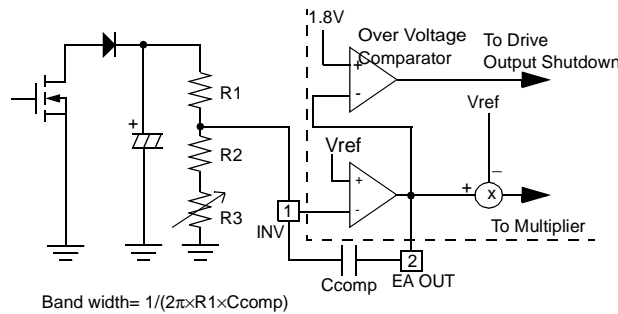

Fig.2.1 Error Amp and Over Voltage Comparator

Over Voltage Protection

The low bandwidth (typically below 20Hz) characteristic of Error Amplifier control loop results in output voltage runaway condition. This condition can occur during initial start-up, sudden load removal, or during output arcing. The over voltage comparator monitors the output voltage of the error amplifier. When load is removed, error amp output swings lower than 1.8V, comparator is triggered high and output driver is turned off till the error amp inverting input voltage drops below 2.5V. At this point, the error amp output swings positive, turns the output driver back on. .

Multiplier

A single quadrant, two input multiplier is the critical element that enables this device to get power factor correction. One input of multiplier (Pin 3) is connected to an external resistor divider which monitors the rectified ac line. The other input is internally driven by a DC voltage which is the difference of error amplifier output (Pin 2) and reference voltage, Vref. The multiplier is designed to have an extremely linear transfer curve over a wide dynamic range, 0V to 3.8V for Pin 3, and 2.5V to 4.5V for error amplifier output under all line and load conditions.

The multiplier output controls the current sense comparator threshold as the ac voltage traverses sinusoidally from zero to peak line. This allows the inductor peak current to follow the ac line thus forcing the average input current to be sinusoidal. In other words, this has the effect of forcing the MOSFET on-time to track the input line voltage, resulting in a fixed drive output on-time, thus making the preconverter load appear to be resistive to the ac line.

The equation below describes the relationship between multiplier output and inputs.

$$V_{mo} = K \times V_{m1} \times (V_{m2} - V_{ref})$$

K : Multiplier gain

V_{m1}: Voltage at Pin 3

V_{m2}: Error amp output voltage

V_{mo}: Multiplier output voltage

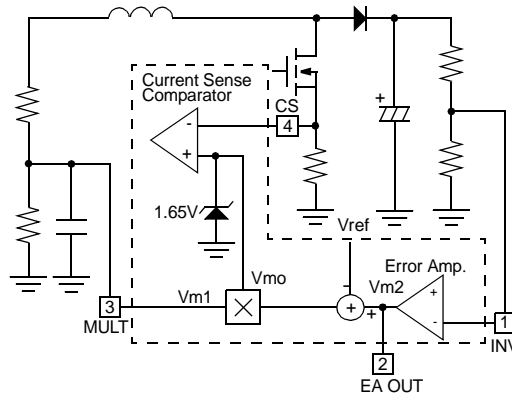

Fig.3.1 Multiplier Block

Current Sense Comparator

The current sense comparator adopts the RS latch configuration to ensure that only a single pulse appears at the drive output during a given cycle. MOSFET drain current is converted to voltage using an external sense resistor in series with the external power MOSFET. When sense voltage exceeds the threshold set by the multiplier output, the current sense comparator terminates the gate drive to the MOSFET and resets the PWM latch. The latch ensures that the output remains in a low state after the MOSFET drain current falls back to zero.

The peak inductor current under normal operating conditions is controlled by the multiplier output, V_{mo} . Abnormal operating conditions occur during preconverter start-up at extremely high line or as output voltage sensing is lost.

Under these conditions, the multiplier output and current sense threshold will be internally clamped to 1.65V. Therefore, the maximum peak switch current is limited to:

$$I_{pk(max)} = 1.65V / R_{sense}$$

An internal R/C filter has been included to attenuate any high frequency noise that may be present on the current waveform. This circuit block eliminates the need for an external R/C filter otherwise required for proper operation of the circuit.

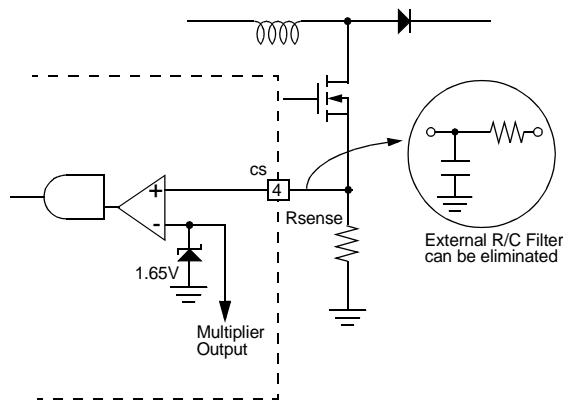

Fig. 4.1 Current Sense Circuit

Zero Current Detector

KA7526 operates as a critical conduction current mode controller. The power MOSFET is turned on by the zero current detector and turned off when the peak inductor current reaches the threshold level established by the multiplier output. The slope of the inductor current is indirectly detected by monitoring the voltage across a separate winding and connecting it to the zero current detector Pin 5.

Once the inductor current reaches ground level, the voltage across the winding reverses polarity. When the Idet input falls below 1.8V, the comparator output is triggered to the low state.

To prevent false tripping, 240mV of hysteresis is provided. The zero current detector input is internally protected by two clamps.

The upper 7.5V clamp prevents input over voltage breakdown while the lower 0.75V clamp prevents substrate injection. An internal current limit resistor protects the lower clamp transistor in case the Idet pin is accidentally shorted to ground.

A watchdog timer function was added to the IC to eliminate the need for an external oscillator when used in stand-alone applications. The timer provides a means to automatically start or restart the preconverter if the drive output has been off for more than 300us after the inductor current reaches zero.

Drive Output

The KA7526 contains a single totem-pole output stage specifically designed for direct drive of power MOSFET. The drive output is capable of up to 500mA peak current with a typical rise and fall time of 130ns, 50ns each with a 1.0nF load. Additional internal circuitry has been added to keep the drive output in a sinking mode whenever the UVLO is active. This characteristic eliminates the need for an external gate pull-down resistor. Internal voltage clamping ensures that output driver is always lower than 13V when supply voltage variation exceeds more than rated V_{gs} threshold (typ 20V) of the external MOSFET. This eliminates an external zener diode and extra power dissipation associated with it that otherwise is required for reliable circuit operation.

APPLICATION CIRCUIT #1

< 90 ~ 265VAC Input, 400VDC, 32W×2 Lamps Self-oscillating Ballast >

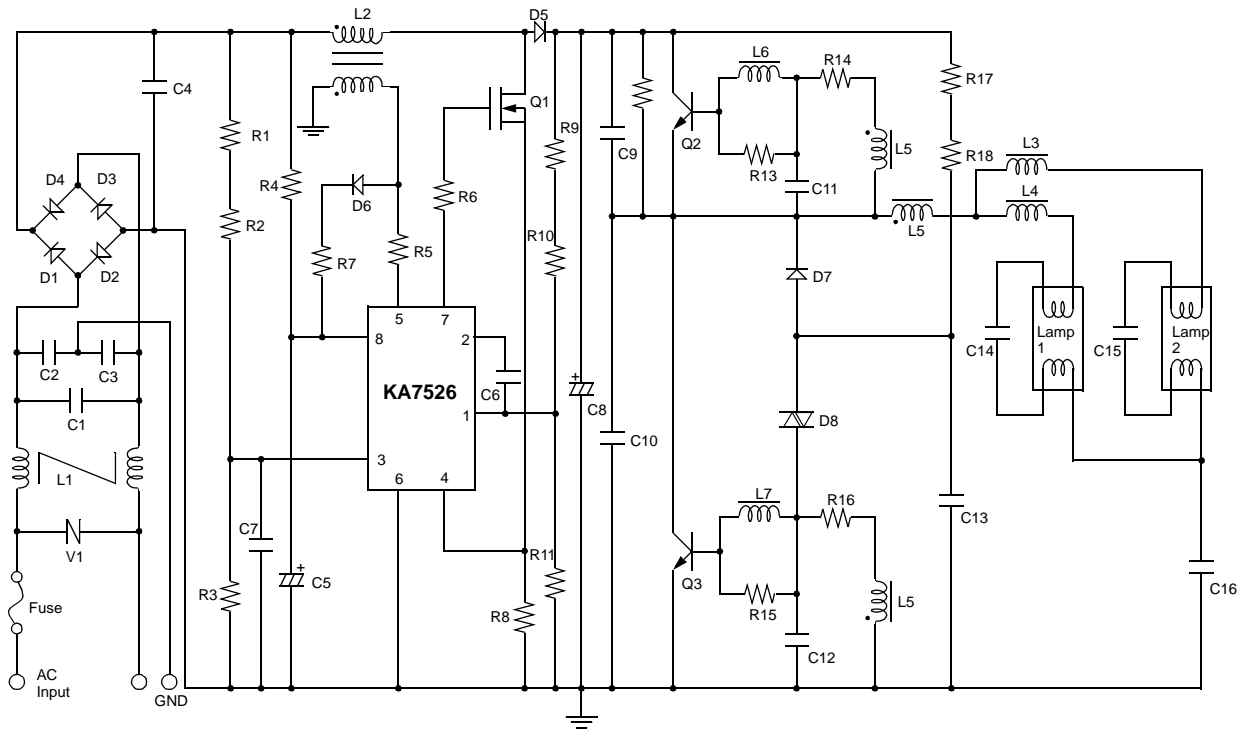

Component Listing (for Application circuit #1)

Reference	Value	Part Number	Manufacturer
R1, 2	1.2M Ω -F, 1/4W	26mm Type	-
R3	11k Ω -F, 1/4W	26mm Type	-
R4	150k Ω , 1/2W	26mm Type	-
R5	22k Ω -J, 1/4W	26mm Type	-
R6, 13, 15	47 Ω -J, 1/4W	26mm Type	-
R7	3.3 Ω , 1/4W	26mm Type	-
R8	1 Ω -J, 1W	26mm Type	-
R9	180k Ω -F, 1/4W	26mm Type	-
R10	820k Ω -F, 1/4W	26mm Type	-
R11	6.8k Ω -F, 1/4W	26mm Type	-
R12, 17, 18	390k Ω -J, 1/4W	26mm Type	-
R14, 16	8.2 Ω -J, 1/4W	26mm Type	-
C1	0.15 μ F, 630V	MEP-CAP	-
C2, 3	2200pF, 3000V	Y-CAP	-
C4	0.22 μ F, 630V	MPE-CAP	-
C5	22 μ F, 35V	Electrolytic	-
C6	0.33 μ F, 25V	Ceramic	-
C7	1000pF, 50V	Ceramic	-
C8	47 μ F, 450V	Electrolytic	-
C9	4700pF, 630V	PPF-CAP	-
C10	2200pF, 630V	PPF-CAP	-
C11, 12	0.15 μ F, 63V	MPF-CAP	-
C13	0.1 μ F, 50V	Ceramic	-
C14, 15	8200pF, 1000V	PP-CAP	-
C16	0.15 μ F, 630V	MEP-CAP	-
D1, 2, 3, 4, 7	1000V, 1A	IN4007GP	-
D5	1000V, 1.5A	BYV26C	Philips
D6	75V, 150mA	IN4148	-
D8	-	N413N (DIAC)	-
L1	DR 10 \times 12	DIT-010	-
L2	EI 2519	DBT-002	-
L3, 4	EI 2820	DPT-086	-
L5	SB5S 8 \times 3 \times 4	DDT-005	-
L6, 7	10 μ H	BS24-100K	-
Fuse	-	52NM250V, 3A	-
V1	430V	INR140, 431	-
IC1	-	KA7526	FairChild
Q1	500V, 4.5A	QFP6N50	FairChild
Q2, 3	400V, 5A	KSC5305D	FairChild

Application Circuit #2

< 90 ~ 265VAC Input, 400VDC, 32W×2 Lamps External-oscillating Ballast >

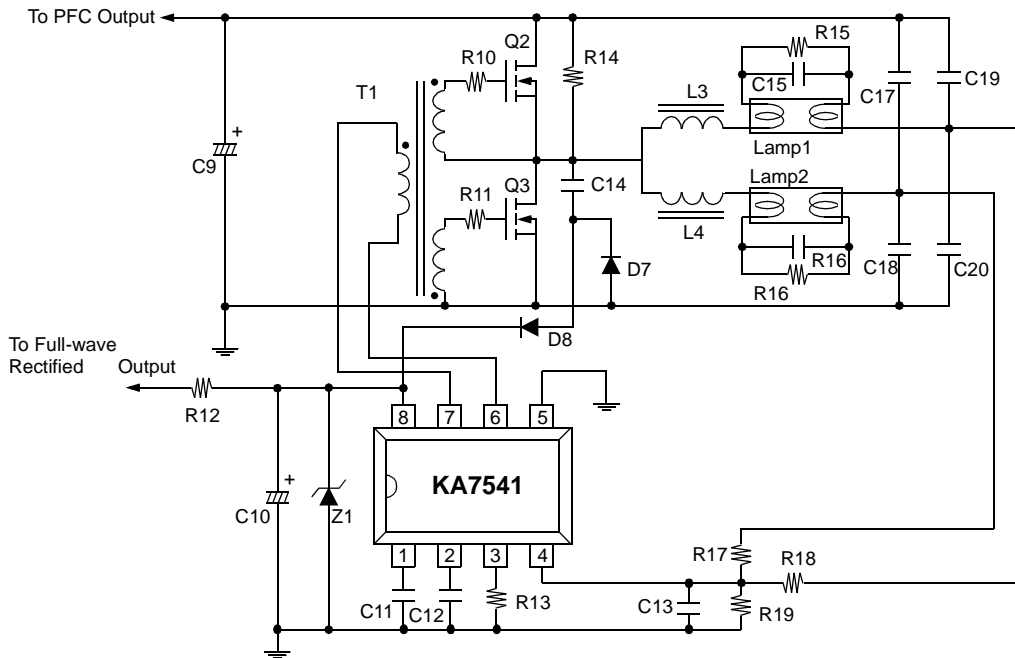
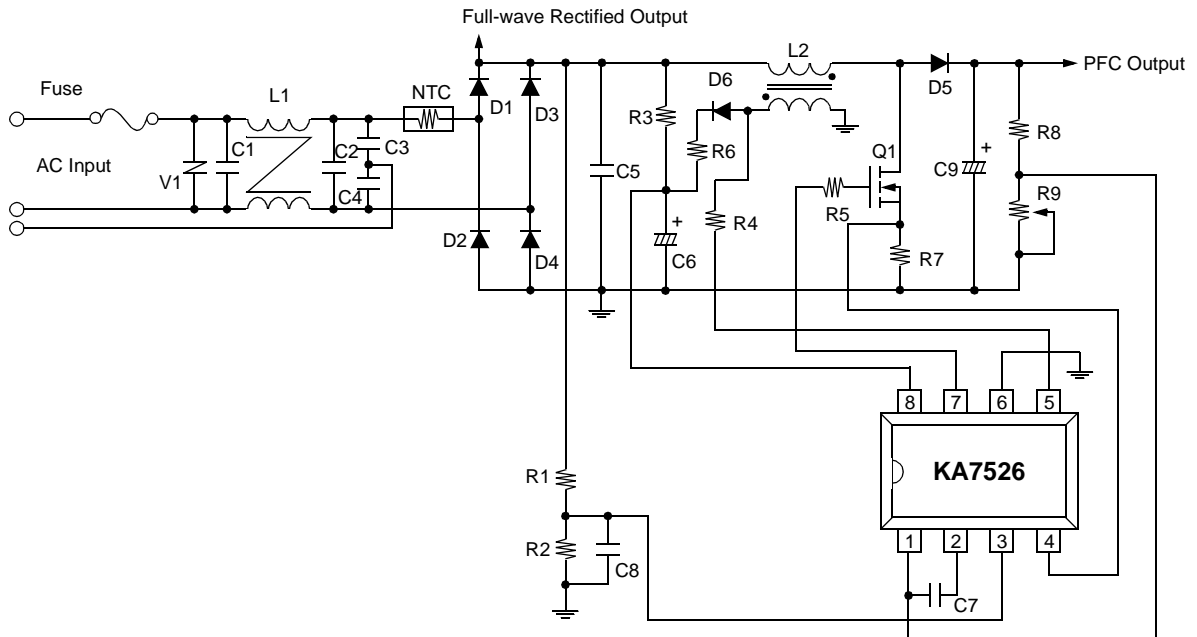

Component Listing (for Application Circuit #2)

Reference	Value	Part Number	Manufacturer
R1	2.2M Ω -F, 1/4W	26mm Type	-
R2	12k Ω -F, 1/4W	26mm Type	-
R3, 12	150k Ω , 1/2W	26mm Type	-
R4	22k Ω -J, 1/4W	26mm Type	-
R5, 10, 11	47 Ω -J, 1/4W	26mm Type	-
R6	3.3 Ω , 1/4W	26mm Type	-
R7	1 Ω -J, 1W	26mm Type	-
R8	1.2M Ω -F, 1/4W	26mm Type	-
R9	10k Ω Variable Resistor	-	-
R13	22k Ω -F, 1/4W	26mm Type	-
R14	180k Ω -J, 1/4W	26mm Type	-
R15, 16	330k Ω -J, 1/4W	26mm Type	-
R17, 18	680k Ω -J, 1/4W	26mm Type	-
R19	8.2k Ω -J, 1/4W	26mm Type	-
C1, 2	0.15 μ F, 630V	MEP-CAP	-
C3, 4	2200pF, 3000V	Y-CAP	-
C5	0.1 μ F, 400V	MPE-CAP	-
C6	22 μ F, 35V	Electrolytic	-
C7	0.33 μ F, 25V	MPE-CAP	-
C8	0.01 μ F, 25V	MPE-CAP	-
C9	47 μ F, 450V	Electrolytic	-
C10	47 μ F, 35V	Electrolytic	-
C11	0.22 μ F, 25V	MPE-CAP	-
C12	180pF, 25V	Ceramic	-
C13	0.1 μ F, 25V	MPE-CAP	-
C14	1000pF, 630V	MPE-CAP	-
C15, 16	4700pF, 1000V	MPE-CAP	-
C17, 18, 19, 20	6800pF, 630V	MPE-CAP	-
D1, 2, 3, 4	1000V, 1A	1N4007	-
D5	FRD(25nS)	BYV26C	Philips
D6	75V, 150mA	1N4148	-
D7,8	1000V, 1.5A	1N4937	-
L1	80mH	BSF2125	-
L2	1.2mH (100T: 7T) Litz Wire or USTC	EI2820	-
L3, 4	3.1mH Litz Wire or USTC	EI2820	-
T1	1.2mH(35T:24T)	EE1614	-
Fuse	-	52NM250V, 3A	-
V1	430V	INR140, 431	-
Q1, 2, 3	500V, 6A	SKP6N50	FairChild
Z1	15V, 1W	-	-

Mechanical Dimensions

Package

Dimensions in millimeters

8-DIP

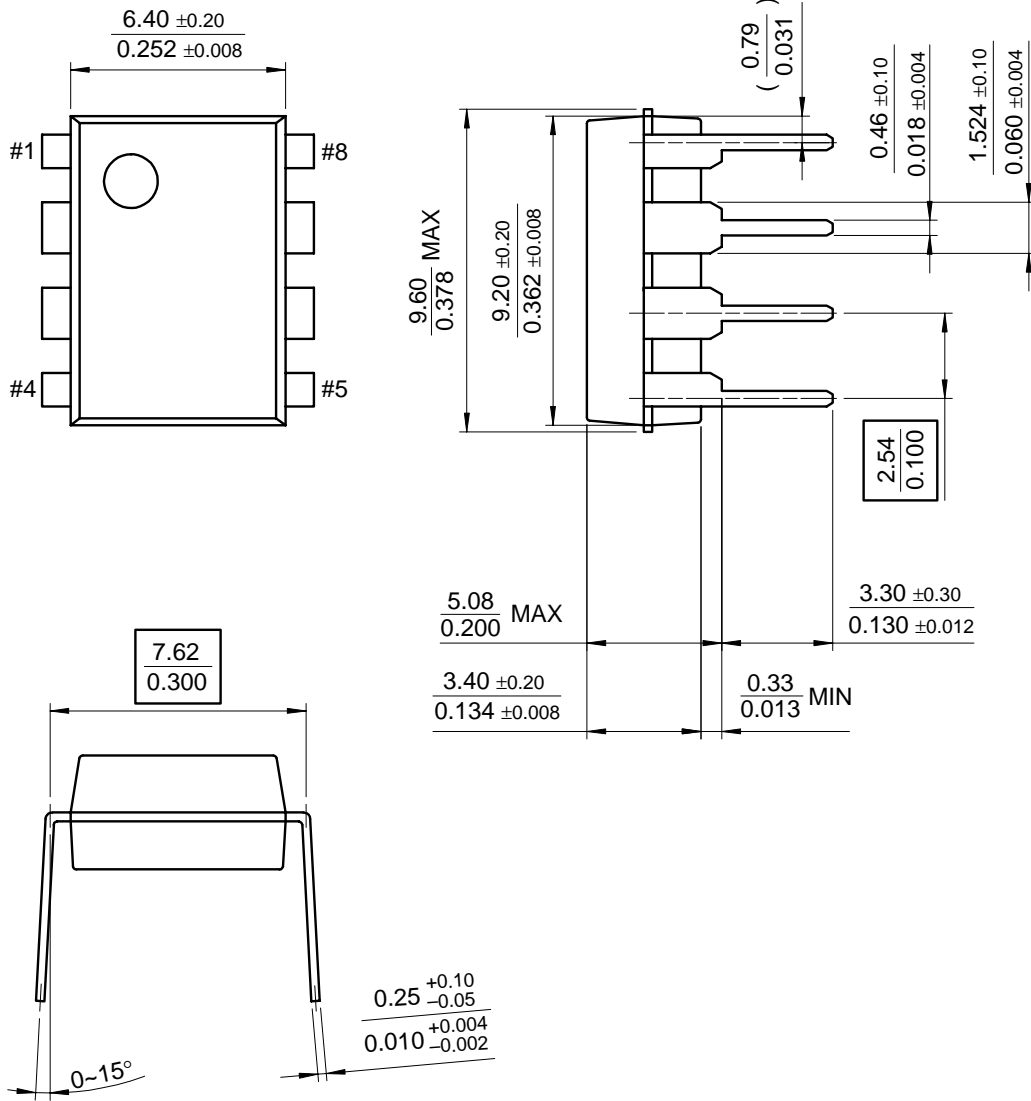

Mechanical Dimensions (Continued)

Package

Dimensions in millimeters

8-SOP

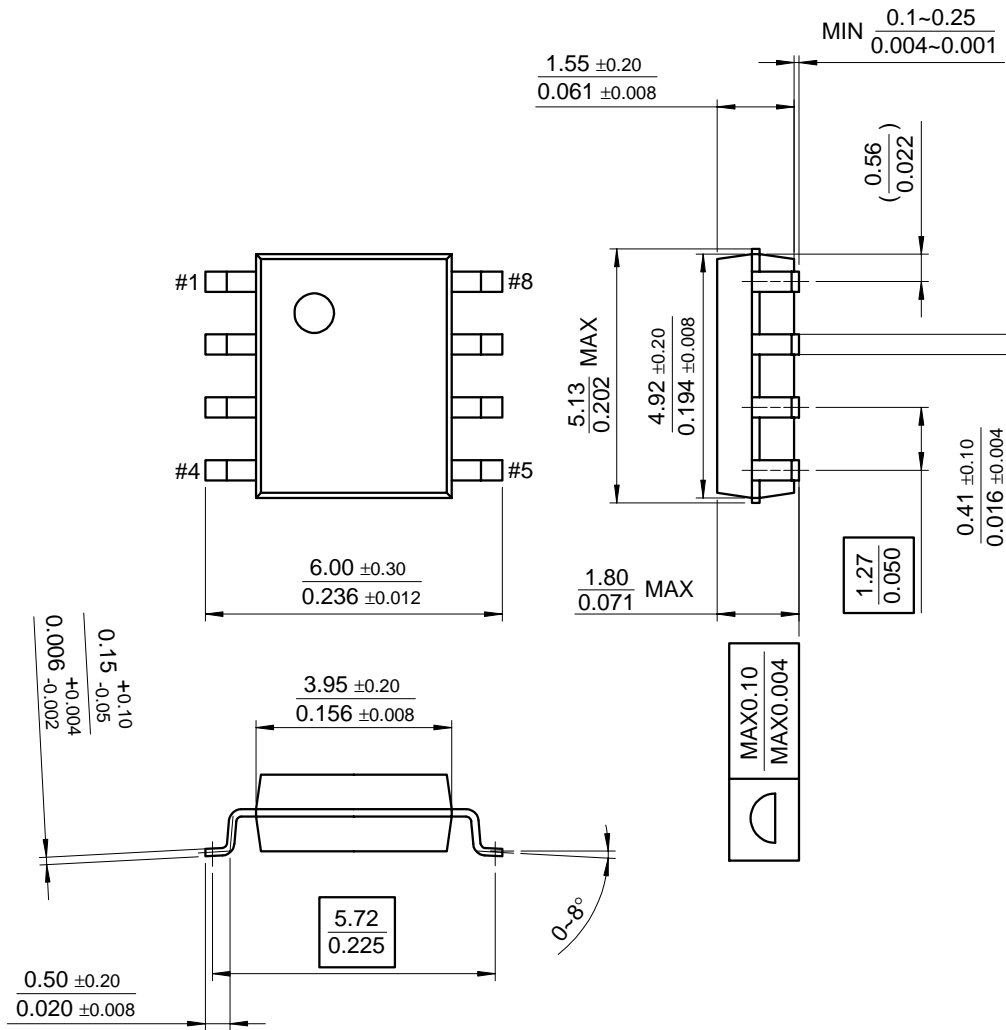

Ordering Information

Product Number	Package	Operating Temperature
KA7526	8-DIP	-25 ~ +125°C
KA7526D	8-SOP	

DISCLAIMER

FAIRCHILD SEMICONDUCTOR RESERVES THE RIGHT TO MAKE CHANGES WITHOUT FURTHER NOTICE TO ANY PRODUCTS HEREIN TO IMPROVE RELIABILITY, FUNCTION OR DESIGN. FAIRCHILD DOES NOT ASSUME ANY LIABILITY ARISING OUT OF THE APPLICATION OR USE OF ANY PRODUCT OR CIRCUIT DESCRIBED HEREIN; NEITHER DOES IT CONVEY ANY LICENSE UNDER ITS PATENT RIGHTS, NOR THE RIGHTS OF OTHERS.

LIFE SUPPORT POLICY

FAIRCHILD'S PRODUCTS ARE NOT AUTHORIZED FOR USE AS CRITICAL COMPONENTS IN LIFE SUPPORT DEVICES OR SYSTEMS WITHOUT THE EXPRESS WRITTEN APPROVAL OF THE PRESIDENT OF FAIRCHILD SEMICONDUCTOR INTERNATIONAL. As used herein:

1. Life support devices or systems are devices or systems which, (a) are intended for surgical implant into the body, or (b) support or sustain life, and (c) whose failure to perform when properly used in accordance with instructions for use provided in the labeling, can be reasonably expected to result in a significant injury of the user.
2. A critical component in any component of a life support device or system whose failure to perform can be reasonably expected to cause the failure of the life support device or system, or to affect its safety or effectiveness.