

BALLAST CONTROL IC

The KA7531X is a ballast control IC improving power-factor.† The following is the features incorporated in it. It includes PFC control block so that the power-factor can be over 0.99 % and the high voltage at lamp driving block can be maintained constantly. Besides, it prevents the inrush current of lamp discharge and the sputtering. The 3-step soft start function allows lengthen lamp use. The dimming control function is also incorporated to regulate lamp's luminance depending on the intensity of surrounding illumination. The over-current protection, over-heating protection of power switch in driving systems and non-load protection functions are also available.

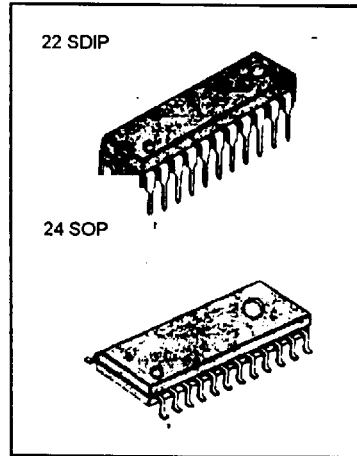

FEATURES

- Power Factor Correction
- Dimming control
- 3 Step Soft start
- ZVS Driving
- Non Lamp Protection
- Protection (OCP, OTP)

ORDERING INFORMATION

Device	Package	Operating Temperature
KA7531	22 SDIP	-25 ~ + 100 °C
KA7531D	24 SOP	

BLOCK DIAGRAM

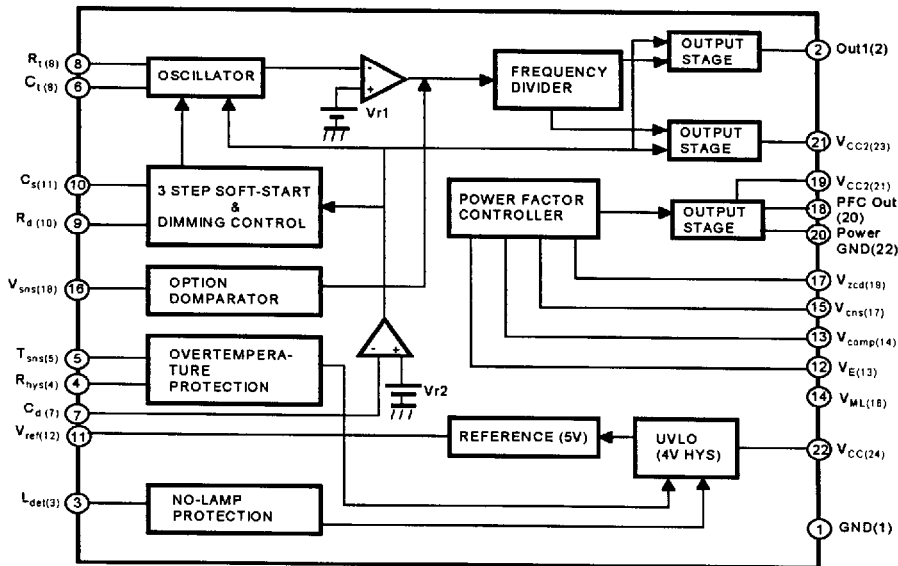

() IS 24SOP PIN NO

ABSOLUTE MAXIMUM RATINGS ($T_A = 25\text{ }^\circ\text{C}$, unless otherwise specified)

Characteristic	Symbol	Value	Unit
Supply Voltage	V_{CC}	17	V
Peak driver output current	$I_{O(P)}$	500	mA
Operating ambient temperature	T_{OPR}	-25 ~ +100	$^\circ\text{C}$
Storage temperature	T_{STG}	-65 ~ +150	$^\circ\text{C}$

ELECTRICAL CHARACTERISTICS

($V_{CC} = 12\text{V}$, $T_A = 25\text{ }^\circ\text{C}$, unless otherwise specified)

Characteristic	Symbol	Test Conditions	Min	Typ	Max	Unit
Under Voltage Lock Out Section						
Start Threshold Voltage	V_{ST}		10	10.8	11.6	V
UVLO Hysteresis	V_{THS}		2.8	3.2	3.6	V
Start-Up Supply Current	I_{ST}	$V_{CC} = 9\text{V}$	0.6		1.4	mA
Operating Supply Current	I_{CC}	$V_{CC} = 14\text{V}$, No Load	8		14	mA
Reference section						
Reference Voltage	V_{REF}		5.0	5.1	5.2	V
Load Regulation	ΔV_{REF}	$0 < I_{REF} < 5\text{mA}$		5	20	mV
Preheating Section						
Preheating Frequency	F_P	$V_{CS} = 0\text{V}$, $R_t = 33\text{K}$, $C_t = 330\text{pF}$	120		160	KHz
Preheating Time Current	I_P	$V_{CS} = 0\text{V}$	7		27	μA
Preheating Dead Time	T_{PD}		2		4	μs
Oscillator Section						
Amplitude	$V_{(OSC)}$		3.0		3.8	V
Normal Frequency	F_N		80		120	KHz
Normal Dead Time	T_{ND}	$V_{CS} = 2\text{V}$	1.7		3.7	μs

ELECTRICAL CHARACTERISTICS(V_{CC} = 12V, T_A = 25 °C, unless otherwise specified)

Characteristic	Symbol	Test Conditions	Min	Typ	Max	Unit
3-step Frequency Section						
Preheating Voltage Range	V _{PR}	R _{DC} = 120K, V _{DS} = 1.75V	0.7		1.3	V
Soft start Voltage Range	V _{ST}	R _{DC} = 120K, V _{DS} = 1.75V	1.3		1.9	V
Fullpower Voltage Range	V _{FR}	R _{DC} = 120K, V _{DS} = 1.75V	2.8		3.4	V
Dimming Voltage Range	V _{DR}	R _{DC} = 120K, V _{DS} = 1.75V	3.5		4.1	V
Oscillator Section						
Dimming 50 % Frequency	F _{DIM}	R _{DC} = 120K, V _{DS} = 1.75V	100		140	KHz
Dimming Current	I _{DIM}	R _D = 120k Ω				μ A
Output Section for Ballast Control Part						
Rising Time (NOTE 2)	T _R	No Load		80	120	ns
Falling Time (NOTE 2)	T _F	No Load		20	60	ns
High Voltage	V _{OH}	I _O = 30mA	7	8		V
Low Voltage	V _{OL}	I _O = 30mA		0.1	0.4	V
Over Temperature Protection						
High Temperature Voltage	V _{HT}		0.7		1.3	V
Reset Temperature Voltage	V _{RT}		2.1		2.9	V
Hysteresis Max Current	I _{HYS}	R _{HYS} = 50K	80		120	μ A
Option Comparator						
Option Comparator Voltage	V _{OPT}		2.4		3.2	V
No Lamp Protection						
No Lamp Protection Voltage	V _{NL}		1.2		1.7	V
Error Amplifier Section						
Input Offset Voltage (NOTE 2)	V _{IDL}		-1.5		15	mV
Input Bias Current	I _{BIAS}		-1	-0.1	1	μ A

ELECTRICAL CHARACTERISTICS

 (V_{CC} = 12V, T_A = 25 °C, unless otherwise specified)

Characteristic	Symbol	Test Conditions	Min	Typ	Max	Unit
Error Amplifier Section						
Large Signal Openloop Voltage Gain (NOTE2)	GV1		60	100		dB
Output Current	Source	I _{SOURCE}	2			mA
	Sink	I _{SINK}			-2	mA
Output Voltage Range	Low	V _{LO}			1.2	V
	High	V _{HI}	4			V
Unity-gain Bandwidth (NOTE2)	UBW			1.0		MHz
Phase Margin (NOTE2)	MPH			57		
Multiplier Section						
M1 Input Voltage Range (NOTE2)	V _{I(M1)}		0		2	V
M2 Input Voltage Range (NOTE2)	V _{I(M2)}		$\frac{V_{REF}}{2}$		$\frac{V_{REF} + 1}{2}$	V
Input Bias Current	I _{BIAS2}		-2		2	μ A
Multiplier Gain (NOTE2)	GV2	VM1 = 0.5V, VM2 = 3.0V		0.8		V
Current-Sense Section						
Input Offset Voltage (NOTE2)	V _{IOS}		-10		10	mV
Input bias Current	I _{BIAS3}	0V ≤ V _{CS} ≤ 1.7V	-5	2	5	μ A
Delay to Output (NOTE2)	td(s)			200	500	ns
Zero-Current-Detect Section						
Input Voltage threshold	V _{TH2}		1.2		1.8	V
Hysteresis	V _{HYS2}			200		mV
Input Low Clamp Voltage	V _{IC(L)}	I _{DET} = -100 μ A			0.95	V
Input High Clamp Voltage	V _{IC(H)}	I _{DET} = 3mA	6.1	7.12		V

ELECTRICAL CHARACTERISTICS

(V_{CC} = 12V, T_A = 25 °C, unless otherwise specified)

Characteristic	Symbol	Test Conditions	Min	Typ	Max	Unit
Zero-Current-Detect Section						
Input Current	I _I	0.9 ≤ V _{DET} ≤ 6V		± 5		μ A
Input High/Low	I _{cd}	V _{DET} < 0.9V			-3	mA
Clamp Diode Current		V _{DET} > 6V	+3			
Output Section for PFC part						
Rising time (NOTE1)	T _{R2}	No Load		100	120	ns
Falling time (NOTE2)	T _{R2}	No Load		90	110	ns
High Voltage	V _{OH2}		7	9		V
Phase Margin	V _{OL2}			0.2	1.5	V
Self - Starting Section						
Self - Starting Time (NOTE2)	T _{SS}		12			μ s
Delay Timer Section						
Delay Timer Current	I _{CD}		6		14	μ A
Delay Timer Voltage	V _{CD}		2.5		3.5	V

NOTE1. V_{CC} ought to set up 10V after threshold voltage approve.

NOTE2. GV2 = Vo(M) / (VM1 × (VM2 - Vref/2))

PIN CONNECTION (top view)

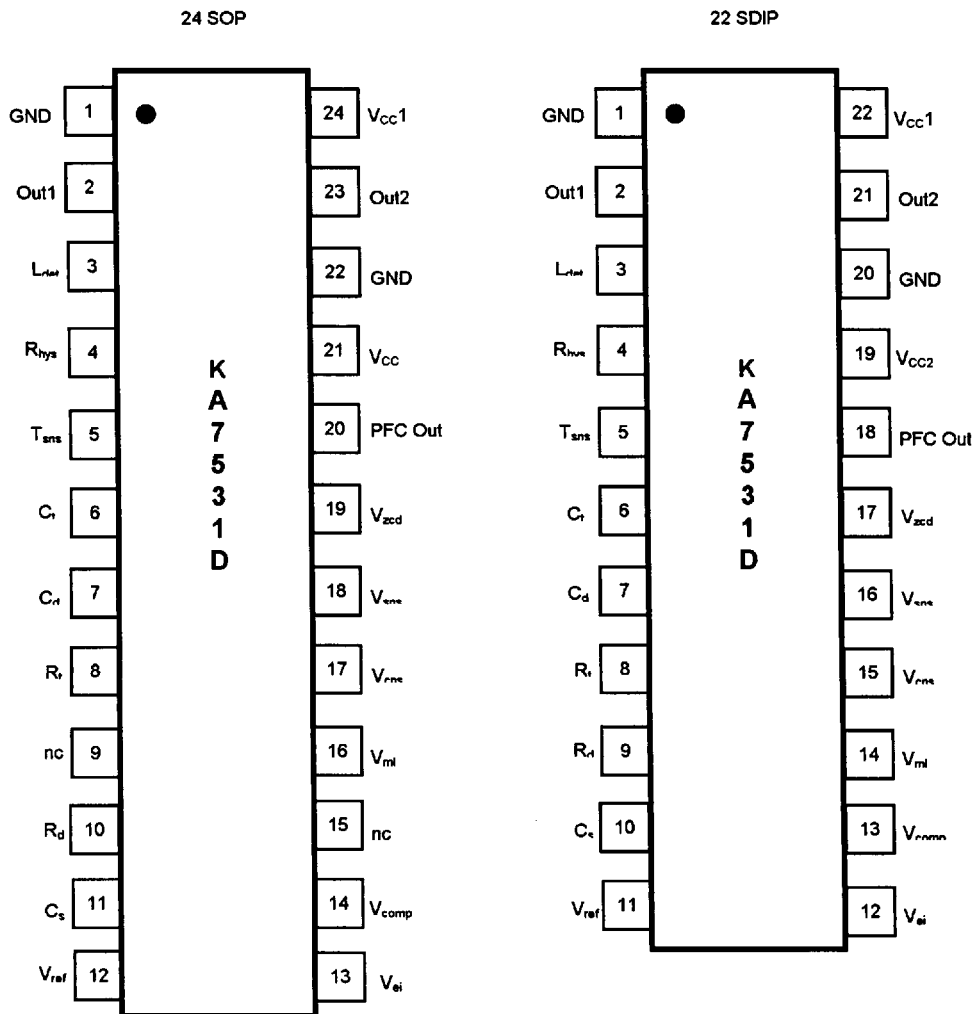

PARTS LIST (KA7531/D)

Part	Value	Part	Value	Part	Value
R1	1.8K Ω 1/2W	R30	1K Ω	NTC2	KTD-350
R2	10K Ω 1/2W	VR1	500K Ω		
R3	100K Ω 1/2W				
R4	51K Ω	C1	0.1 μ F 250V		
R5	33K Ω	C2	0.1 μ F 250V	D1	1N4937
R6	240K Ω 1/2W	C3	4700pF 250V	D2	1N4937
R7	10 Ω 1/2W	C4	4700pF 250V	D3	15V 1W
R8	27 Ω	C5	563 600V	D4	1N4937
R9	22K Ω	C6	103 40V	D5	1N4937
R10	330 Ω	C7	104 16V	D6	6.2V 0.5W
R11	1K Ω 1/2W	C8	331 10V	D7	1N4937
R12	6.2K Ω 1/2W	C9	103 10V	D8	1N4937
R13	150K Ω	C10	10 μ F 16V	D9	1N4937
R14	0.5 Ω 1W	C11	104 16V	D10	1N4937
R15	51 Ω				
R16	680 Ω	C13	332 10V	Q1	IRF830
R17	51 Ω	C14	100 μ F 25V	Q2	IRF830
R18	680 Ω	C15	47 μ F 450V	Q3	IRF830
R19	1M Ω	C16	152 630V		
R20	1M Ω	C17	562 1000V		
R21	1M Ω	C18	562 1000V	L1	BSF-2125
R22	1M Ω	C19	103 630V	T1	EE1619
R23	2M Ω	C20	103 630V	T2,T3,T4	EI25
R24	2M Ω	C21	1 μ F 10V		
R25	0.5 Ω 1W	C22	22 μ F 16V		
R26	620K Ω	C23	103 630V		B/D
R27	20K Ω	C24	103 630V	IC	KA7531D
R28	430 Ω	TNR	12G471K		
R29	100 Ω 1W	NTC1	10D-11	FUSE	250V/2A

Pin Functions

Symbol	Number		Functions
	SOP	SDIP	
OUT 1	2	2	Output Pin. It drives power switching elements. Its output frequency(f_o) varies from 50 [KHz] \pm 30 [KHz]. The output voltage level is V_{CC} .
OUT 2	23	21	
GND	1	1	IC Ground
GND	22	20	
Ldet	3	3	Non Lamp Detect
R _{HYS}	22	20	Over Temperature Hysteresis Resistor
GND	1	1	It determines the frequency of internal triangular wave generation circuit, and then fixed frequency determines output frequency at Out1 and Out2
GND	22	20	
L _{DET}	3	3	It performs Dimming Control which regulates lamp intensity.
R _{HYS}	4	4	Delay Timer Capacitor
C _s	11	10	It determines soft-start period during first lamp fire starting. $C = i \frac{dt}{dv}$ ($i = 20 \mu A$, $dv = 0.7V$, $dt = 2.4sec$)
V _{EI}	13	12	Error AMP. Input
V _{M1}	16	14	V _{OD} Voltage Multiplier Input
V _{COMP}	14	13	Error AMP. Output
V _{REF}	12	11	5V Reference
V _{CNS}	17	15	Current Sense for PFC
V _{SNS}	18	16	Voltage Sense
V _{ZCD}	19	17	Zero Current Detect
L _{DET}	20	18	Power Factor MOSFET Drive output
T _{SNS}	5	5	Temperature Sense it will be protected with 0.9V below
V _{CC1}	24	22	V _{CC}
V _{CC2}	21	19	

1. SYSTEM SUMMARY

This application note is about functions and designs of electronic ballast, which can drive fluorescent lamp (32w*2) by using a KA7531 (ballast control IC)

1) Excellent power saving capability

- ▶ Power Factor Correction
- ▶ Dimming Control

2) Stable strike and life extension of fluorescent lamp

- ▶ 3 - Step Soft-start
- ▶ Double Hot Spot generation

3) EMI / RFI and minimize radiation noise

- ▶ Zero voltage switching (ZVS)

4) Minimize eye-strain

- ▶ Soft Ignition
- ▶ Stable Lighting Output

5) Improvement of system reliability

- ▶ No load protection
- ▶ Over heating protection
- ▶ Emergency Shut-Down

2. SYSTEM BLOCK DIAGRAM (KA7531/D)

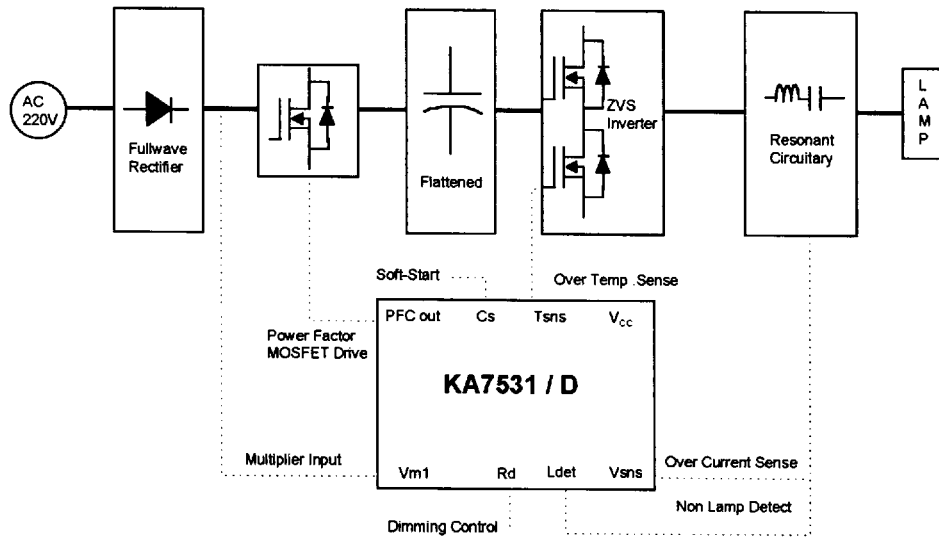

3. APPLICATION CIRCUIT

3-1 Application Circuit

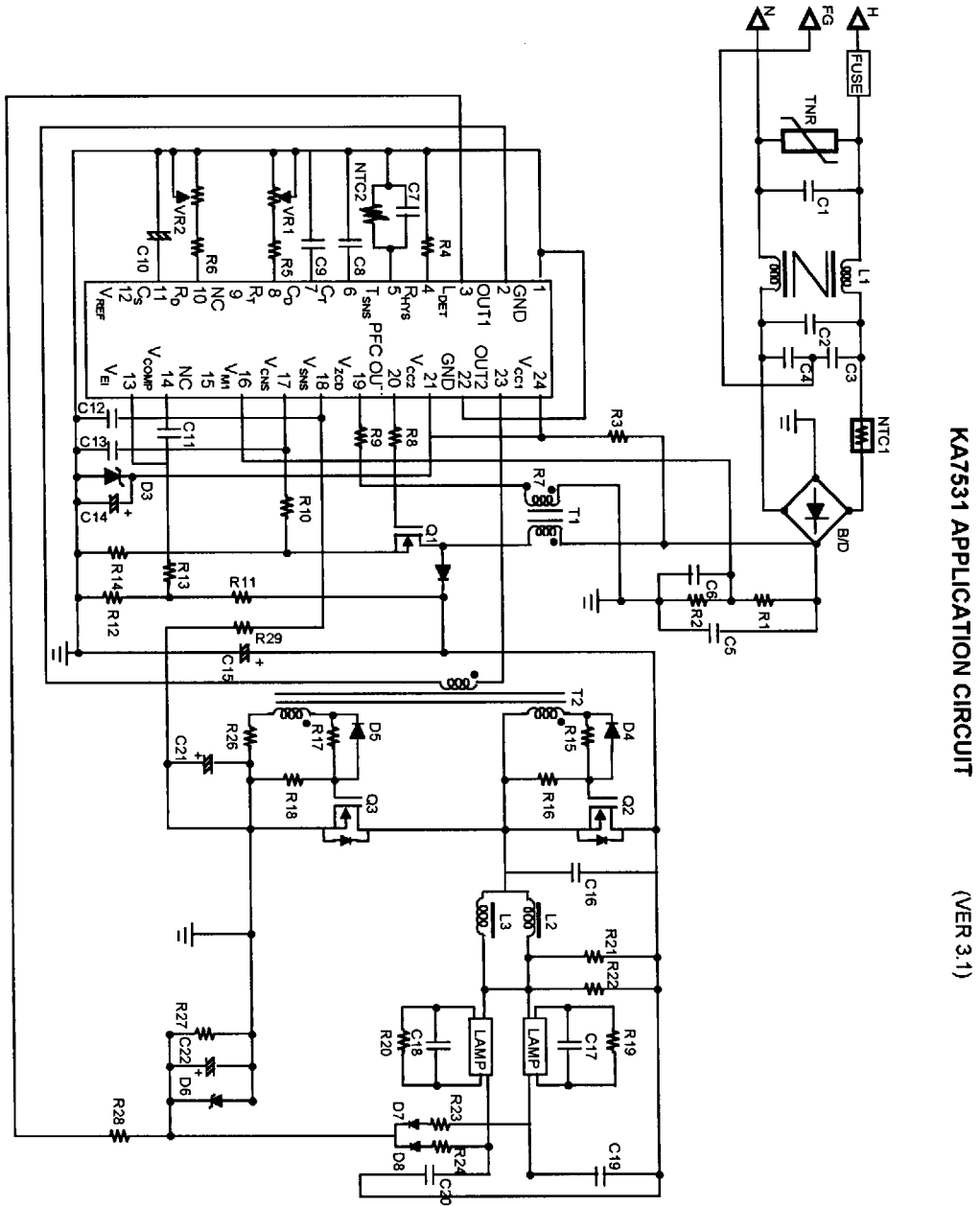

KA7531 APPLICATION CIRCUIT (VER. 3.1)

3-2 Parts List (APP-243)

ITEM	VALUE	ITEM	VALUE	ITEM	VALUE
R1	1.8 M Ω 1/2W	C1	0.1 μ F 250V	TNR	12G471K
R2	10 k Ω 1/2W	C2	0.1 μ F 250V	NTC1	10D - 11
R3	100 k Ω 1/2W	C3	4700 pF 250V	NTC2	KTD5 - 350 (50k Ω)
R4	51 k Ω	C4	4700 pF 250V		
R5	33 k Ω	C5	563 600V	D1	1N4937
R6	120 k Ω	C6	103 40V	D2 - D4	1N4148
R7	27 Ω	C7	104 16V	D5 - D8	1N4937
R8	22 k Ω	C8	331 10V		
R9	330 Ω	C9	103 10V	ZD1	18V 1W
R10	150 k Ω	C10	10 μ F 16V		
R11	1 Ω 1W	C11	104 16V	Q1 - Q3	IRF830
R12	1 M Ω 1/2W	C12	10 μ F 16V		
R13	6.2 k Ω 1/2W	C13	332 10V	L1	BSF-2125
R14	60 k Ω	C14	47 μ F 25V	L2, L3	EI25
R15	51 Ω	C15	47 μ F 450V	T1	EI25
R16	51 Ω	C16	222 630V	T2	EE1619
R17	3.4 Ω	C17	562 1000V		
R18	300 k Ω	C18	562 1000V	B/D	KBL205
R19	390 k Ω	C19	103 630V	IC	KA7531
R20	390 k Ω	C20	103 630V		
R21	1 M Ω	C21	103 630V	FUSE	250V/2A
R22	1 M Ω	C22	103 630V		
R23	20 M Ω	C23	103 10V		
R26	2.2 M Ω				
R27	2.2 k Ω				
VR1	10 k Ω				
VR2	500 k Ω				

3-3 Trans SPEC. (P.C.B TOP VIEW)

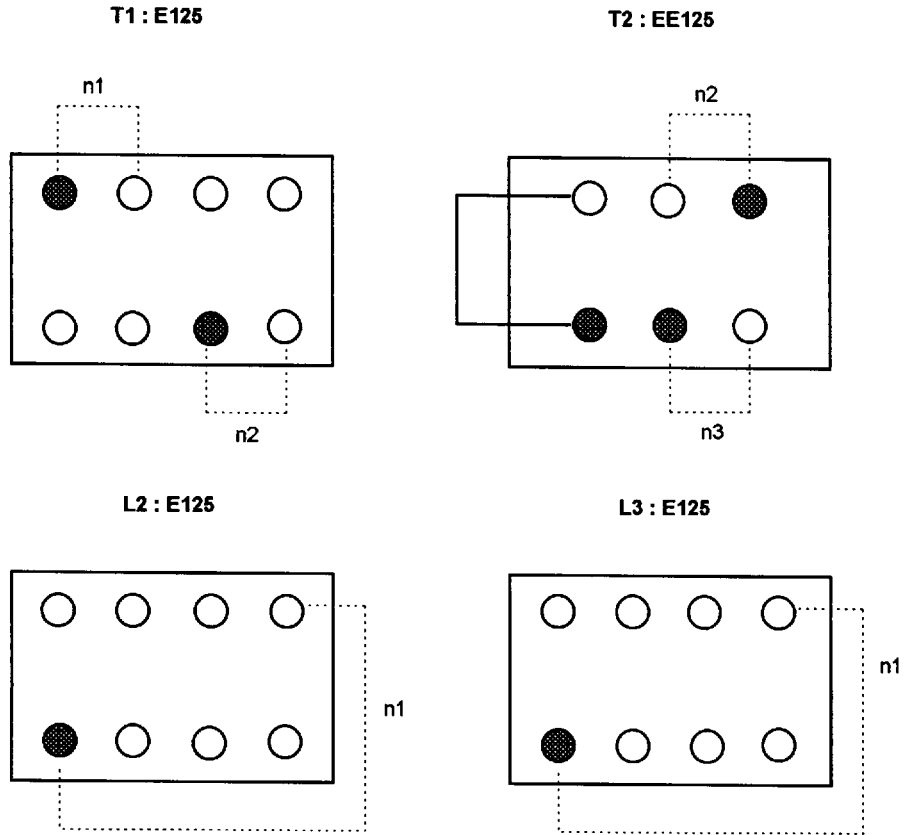

ITEM	Φ	n1	n2	n3	n1 Value	Remark
T1	0.35	120 Turn	11 Turn	-	1.9 mH	
T2	0.25	32 Turn	24 Turn	24 Turn		
L2, L3	0.35	150 Turn	-	-	3.0 mH	

4. FUNCTION BLOCK DESCRIPTION

4 - 1 Start-up Operation

The KA7531 starts to operate when V_{CC} is more than start threshold voltage [10V], and operating current is 10mA. If the V_{CC} decreases less than UVLO (under voltage lock out) hysteresis width, IC's operation will stop. And then all the internal circuit begin to RESET, hold the stand-by state, At this time of this function operate, stand-by state current is about 0.9mA.

4 - 2 Soft - Start

The 3 - step - soft - start function is pre-heat filament for 0.7 [sec] with a frequency that has a 20KHZ higher than normal control frequency of IC. And having high frequency (more than 20 KHZ) decreased to normal frequency linearly for about 0.4 [sec].

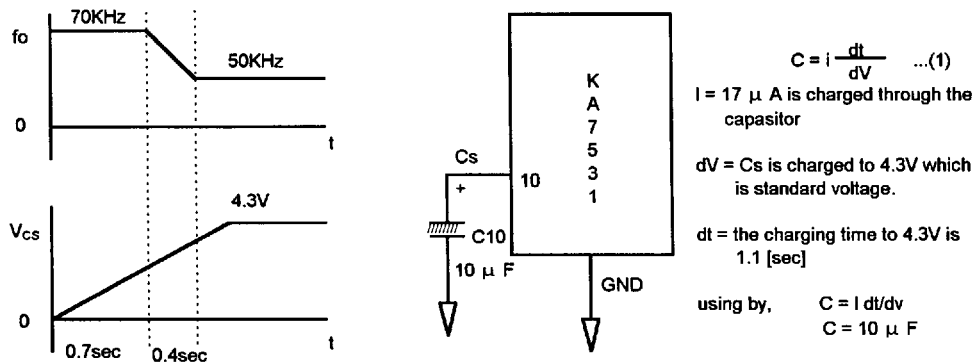

4 - 3 Over Current Protection

In this function, sensing a input and when input becomes over current state, the output of IC will be shut-down. So this system is designed to have a function like that.

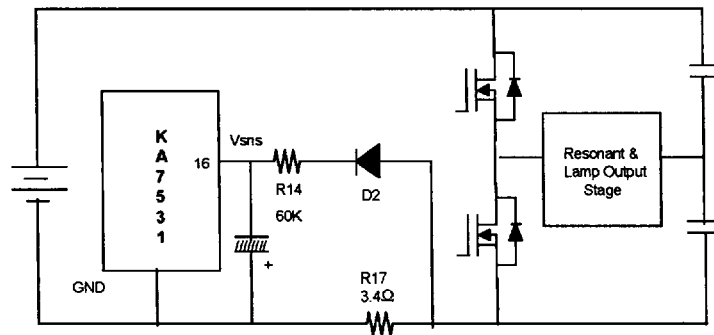

If the voltage level of pin #16 becomes more than 3V, the output will be shut-down . In the normal state, After removal of overcurrent state, IC's output is on-state. To make output on-state, IC's internal latch must be removed. To get above function, UVLO must be changed from off-state to on-state.

4-4 No Load Protection

The KA7531 have a function sensing a 1 lamp insertion and a 2 lamp insertion or not. In case of no load, this system have protection circuit operated and IC's output shut down. When the insertion state change from 1 lamp to 2 lamp, lamp reset function restarting from 3-step soft start is operated. And also new inserted lamps strikes after filament pre-heating.

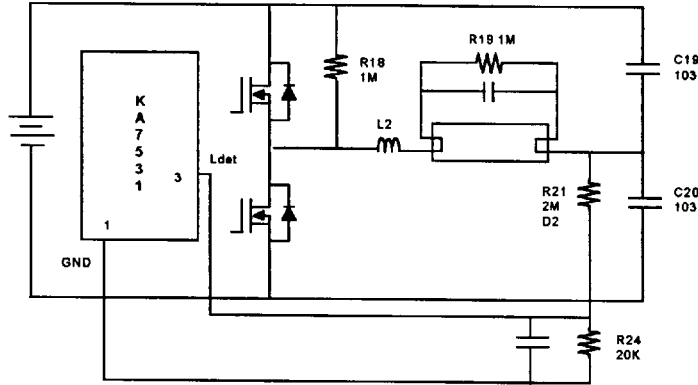

When the pin#3, of IC becomes lower than 1.4V, The output will be shut-down. In the state of lamp insertion, DC voltage is divided by R18, R19, R21, R23. DC link voltage in R23 is supplied to pin#3(Ldet) more than 1.4V

4-5 Over Temperature Protection

This function is designed to protect system by shut-down of IC's output. Using a NTC (negative temperature coefficient) this system sense a emitting heat state of power switching component when sensed temperature is more than specified temperature.

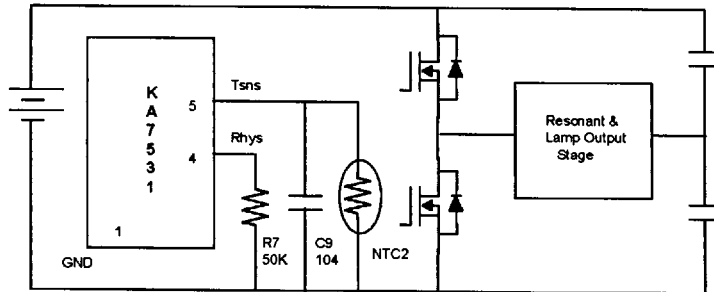

In this circuit, If the voltage level of pin#5 Tsns is less than 0.9V, IC's output is shut-down. Once the system is shut-down, This system is restarted with temperature hysteresis characteristics by voltage level of pin#4. This circuit is designed so that shut-down at the temperature of 90 °C and restart at 50 °C. The NTC have a value of 50k Ω at the temperature of 25 °C.

4 - 6 Dimming Control

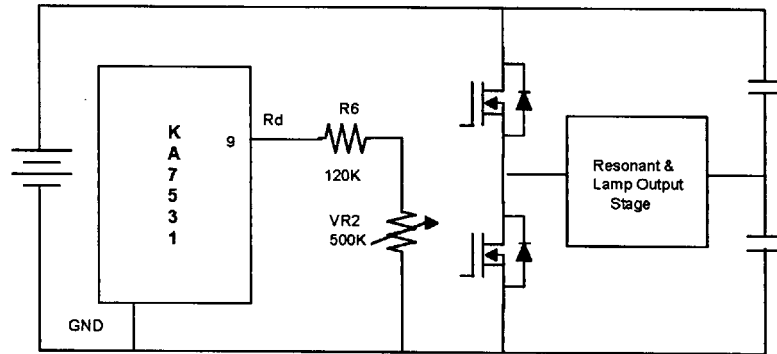

Current flowing into Rd is controlled by adjusting VR2(500K). And this makes output frequency variable. In the end, dimming control is possible.

4 - 7 P.F.C

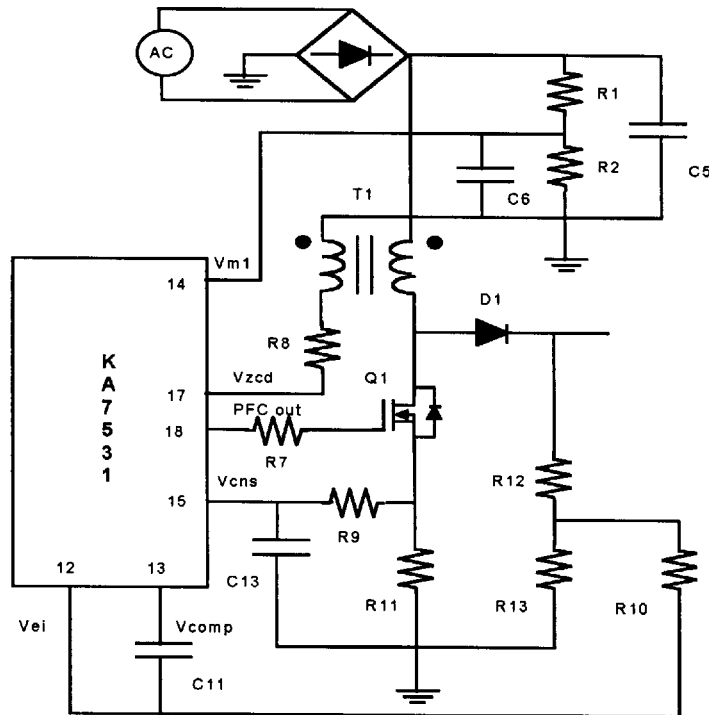

Refer to Power Device (95, 3rd Edition) of SANSUNG Data Book. (Page 73 - 86)

5. FUNCTION COMPARISON TABLE (KA7521 / 7522 / 7531)

Parameter	KA7521	KA7522	KA7531	Remark
1. P. F. C	about 0.67	about 0.67	over 0.99	
2. Soft-Start Function	○	○	○	
3. Input Voltage Variation Protection	AC 220V -20% +50%	AC 220V ± 50%	AC 220V ± 20%	
4. Over-Voltage Protection	○	○	○	
5. Emergency System Protection	○	○	○	
6. Over-Heating Protection	○	○	○	
7. Non-lamp Dtection	○	○	○	
8. Dimming Control	100% ~ 10%	100% ~ 10%	100% ~ 10%	
9. AVS-Driving	○	○	○	
10. ZVS Guard Control	-	○	-	
11. Current Feedback Control	-	○	-	
12. Lamp reset	-	○	-	Preheating function while lamp setting on Power-on stage
13. Input limit & Brown out	-	○	-	
14. Low Temperature sense for preheating time control	-	○	-	
* KA7521 and KA7524 are constructed in a single construction fo KA7531				

42-DIP-600B

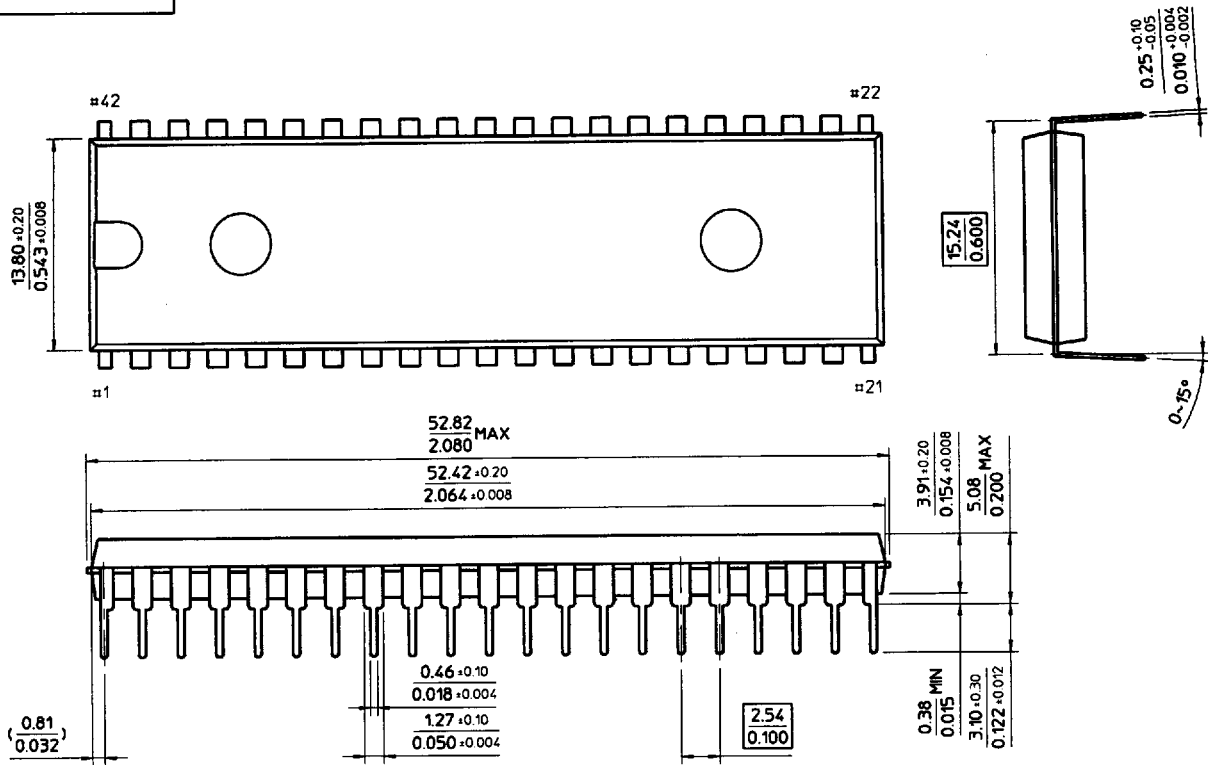

22-SDIP-300

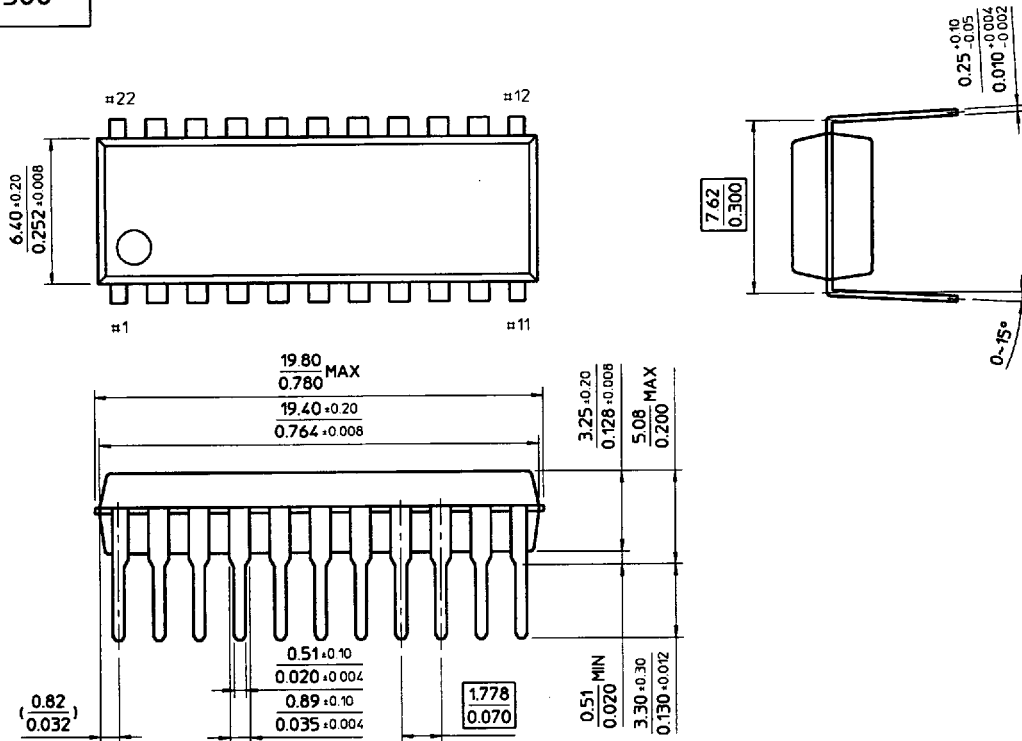

22-SOP-300

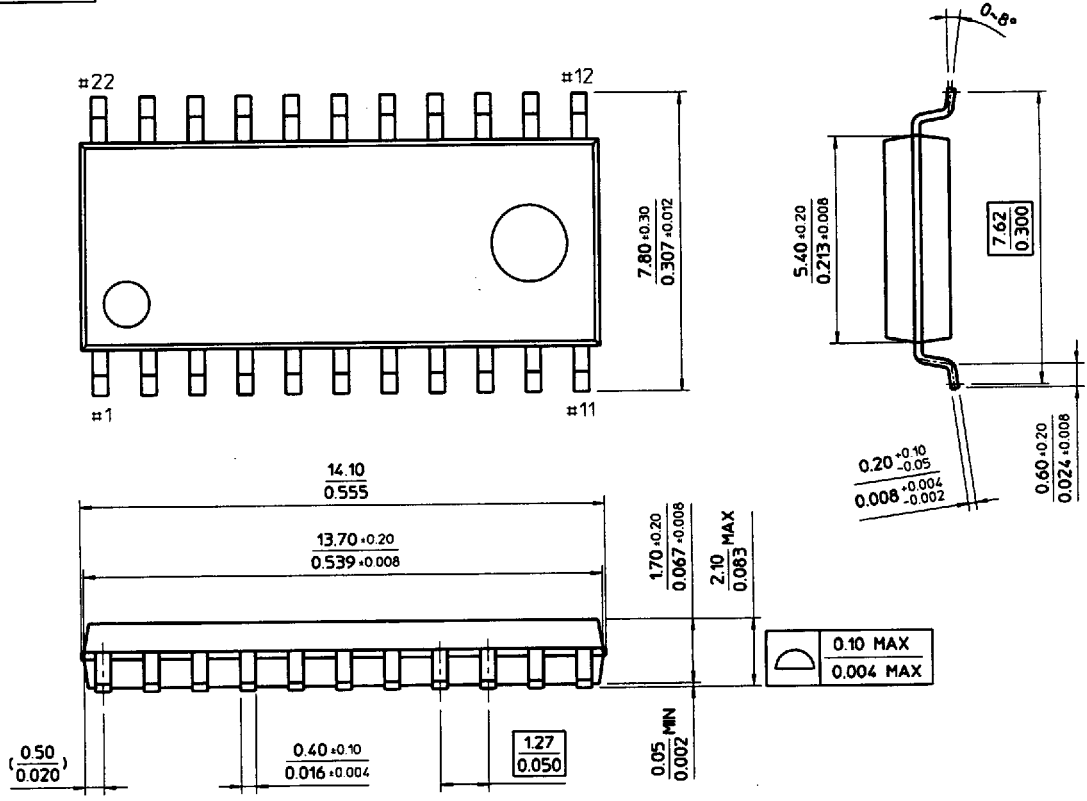

24-SOP-300

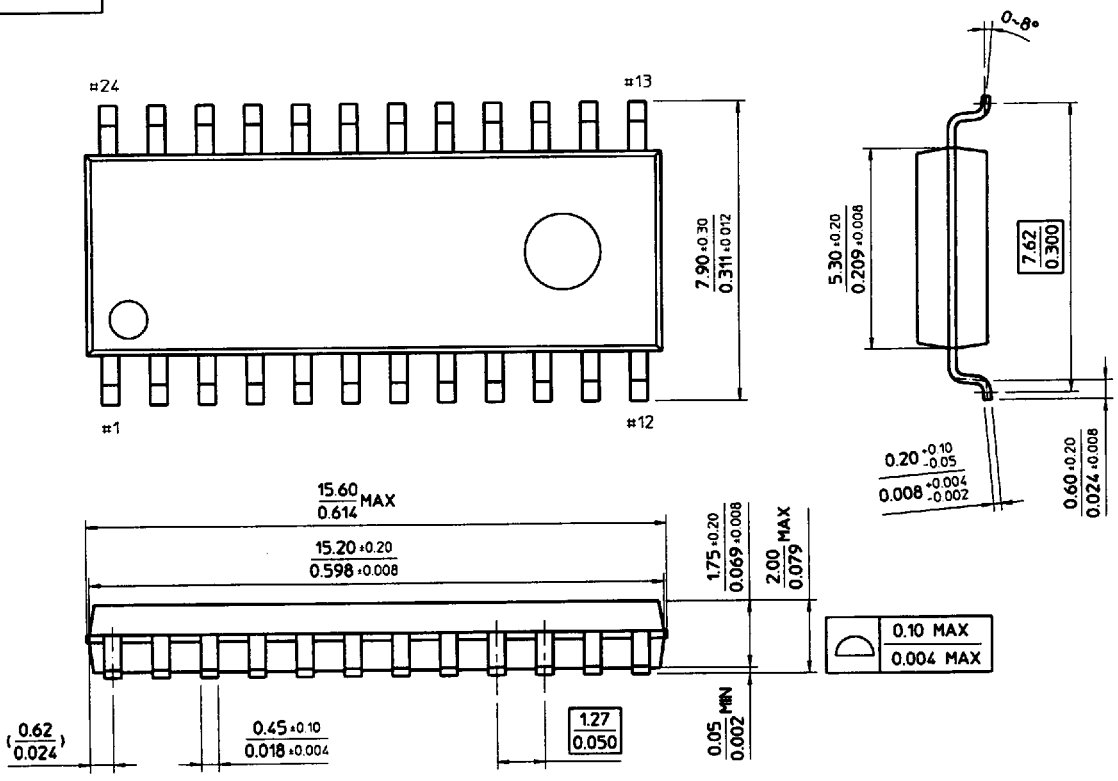

24-SOP-375

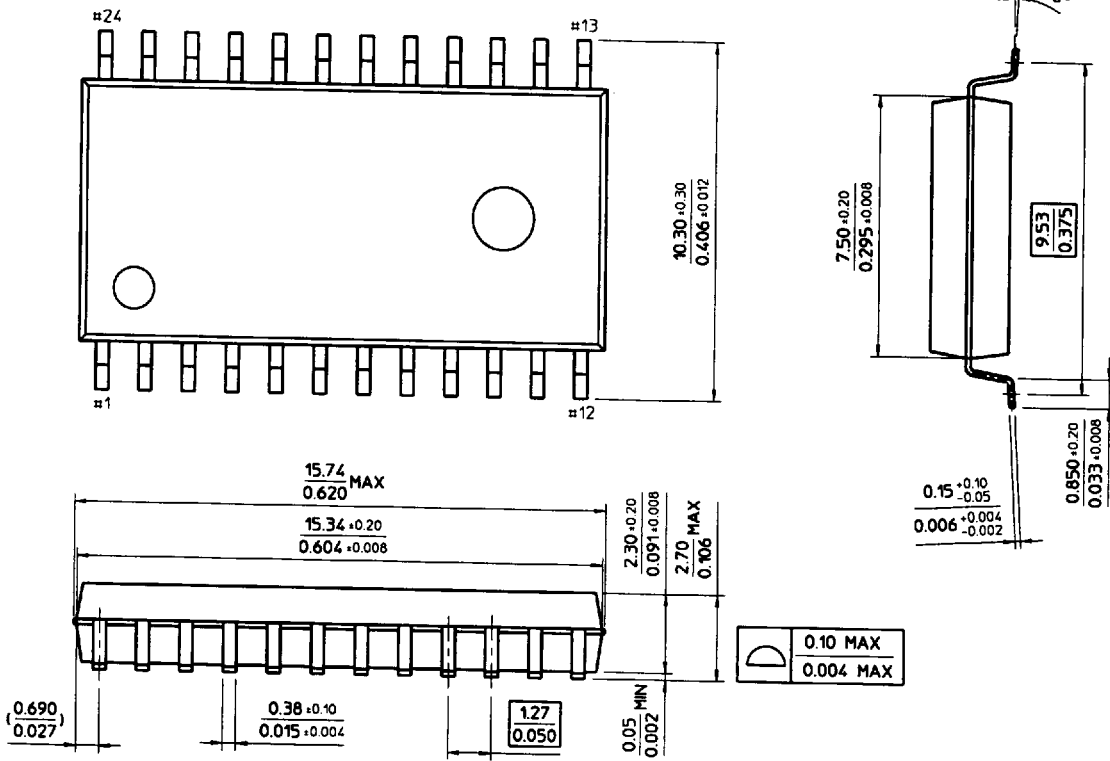

28-SOP-375

