

**INTRODUCTION**

The KA8516 is a designed for FM IF detection on the FLEX pager set. It includes a wide dynamic range audio output, which is easy to connect to an A/D converter. Also it includes a 2-level FSK comparator.

**FEATURES**

- FM IF detector for 4 level FSK
- High transmission rate: 6400bps (Max.)
- Operating voltage range:  $V_{CC1} = 1.1 \sim 4.0V$
- Typical supply current: 1.5mA at 1.4V
- Low battery detection circuit (alarm function): 1.05V
- Voltage regulator:  $V_{reg} = 1.0V$  (Typ.)
- Mixer operating frequency: 10 ~ 50MHz
- Package type: 24-SSOP (0.65mm)

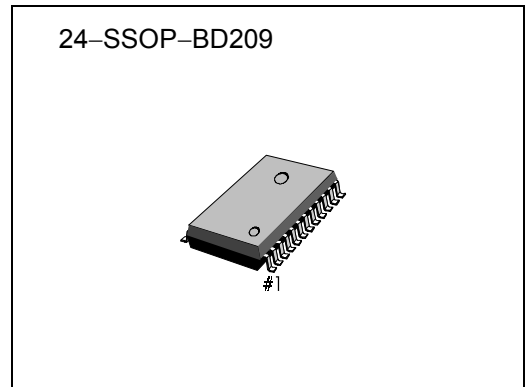

**ORDERING INFORMATION**

Device	Package	Operating Temperature
+KA8516	24-SSOP-BD20	-20°C to +70°C

+: New product

**BLOCK DIAGRAM**

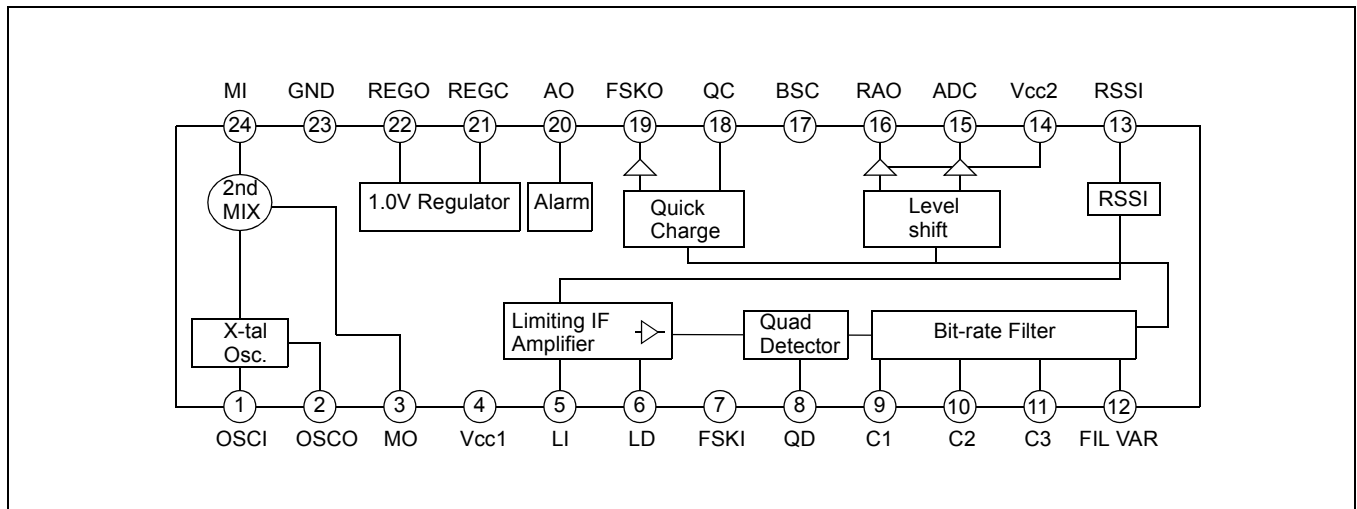

**PIN CONFIGURATION**

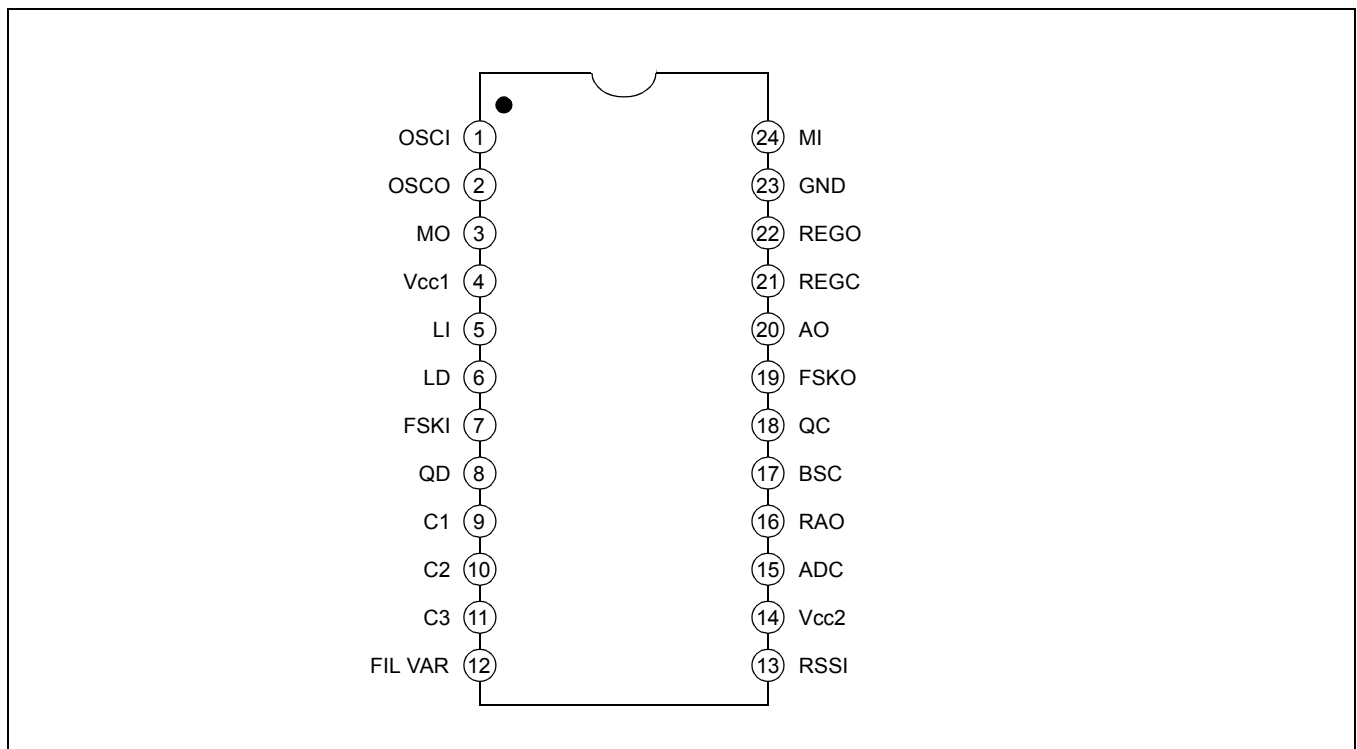

## PIN DESCRIPTION

Pin No	Symbol	Description
1	OSCI	Oscillator input (Base). The oscillator is an internally-biased colpitts type.
2	OSCO	Oscillator output (Emitter).
3	MO	Mixer output. Output impedance $\approx 1.2k\Omega$ . Connect a 455kHz filter between this pin and the LI.
4	$V_{CC1}$	Power supply voltage (Main power).
5	LI	IF limiter amplifier input. Input impedance $\approx 1.2k\Omega$
6	LD	Bypass capacitor connect pin for the IF limiter amp.
7	FSKR1	Differential Amp Reference input on the FSK comparator.
8	QD	Quadrature detection, phase shifter pin.
9	C1	Capacitors for bit-rate filter.
10	C2	
11	C3	
12	FIL VAR	Bit-rate filter selection. High: Internal cut-off frequency will be set to Low. Low : Internal cut- off frequency will be set to High.
13	RSSI	RSSI output The power of received RF signal can be detected by monitoring the limiter amplifier.
14	$V_{CC2}$	Power supply voltage. This power supply to the Level shift circuitry.
15,	ADC	This pin shows DC level of recovered audio signal output.
16	RAO	Recovered audio signal output.
17	BSC	Battery saving control. High: Battery saving off, normal mode operation. Low : Battery saving on, battery save mode operation.
18	QC	Quick charge control. High: Quick charge-discharge on. Low : Quick charge-discharge off.
19	FSKO	FSK signal output.
20	AO	Alarm output. This pin becomes High when $V_{CC1}$ drops below 1.05V.
21	REGC	KA8516 has an internal PNP transistor. But, it also can support an external PNP transistor to control the power.
22	REGO	Regulated voltage output.
23	GND	Ground.
24	MI	Mixer input. Input impedance $\approx 5k\Omega$

## ABSOLUTE MAXIMUM RATINGS

Characteristic	Symbol	Value	Unit
Supply Voltage	$V_{CC1 (MAX)}$	4	V
	$V_{CC2}$	6	V
Power Dissipation	$P_D$	760	mW
Operating Temperature	$T_{OPR}$	-20 ~ +70	°C
Storage Temperature	$T_{STG}$	-55 ~ +125	°C

## ELECTRICAL CHARACTERISTICS

( $V_{CC} = 1.4V \pm 5\%$ ,  $f_{IN (2MIX)} = 21.4MHz$ ,  $f_{DEV} = \pm 4.8kHz$ ,  $f_{MOD} = 800Hz$ ,  $T_a = 25^\circ C$ ,  $FIL\_VAR = "H"$ , unless otherwise specified)

Characteristic	Symbol	Test Conditions	Min.	Typ.	Max.	Unit
Operating current	$I_{CCN}$	No Input Signal	-	1.5	1.75	mA
	$I_{CCS}$	Battery Saving	-	0	10	$\mu A$
Alarm detection voltage	$V_{AD}$	-	1.0	1.05	1.1	V
Alarm low level output voltage	$V_{O (AL)}$	$I = 100\mu A$	-	-	0.4	V
Alarm high level leakage current	$I_{LKG (AL)}$	-	-	-	2	$\mu A$
FSK low level output voltage	$V_L (FSK)$	$I = 100\mu A$	-	-	0.4	V
FSK high level leakage current	$I_{LKG (FSK)}$	-	-	-	2	$\mu A$
Regulator output voltage	$V_{OREG}$	-	0.95	1.0	1.05	V
Quick charge current	$I_C$	-	50	70	-	$\mu A$
Input for -3dB sensitivity	$V_{LIM}$	Mixer Input	-	2.5	7.5	$\mu V_{rms}$
Recovered audio output voltage	$V_{O (RAO)}$	$V_{IN (2MIX)} = 500\mu V_{rms}$	40	60	82	mV <sub>rms</sub>
Mixer conversion gain	$\Delta G_V (M)$	Ceramic Filter loss = -1dB	8	12	16	dB
Signal to noise ratio	S/N	$V_{IN (MIX1N)} = 500\mu V_{rms}$	38	55	-	dB
Total Harmonic Distortion	THD	$V_{IN (MIX1N)} = 500\mu V_{rms}$	-	2.0	3.5	%
Mixer 3rd order intercept point	3RD	-	-	-10	-	dBm
Mixer input resistance	$R_I (MIX)$	-	3.5	5	6.5	k $\Omega$
Limiting amp input resistance	$R_I (LA)$	-	0.6	1.2	1.8	k $\Omega$
AM rejection ratio	AMR	$V_{IN (2MIX)} = 500\mu V_{rms}$ (AM = 30%)	25	40	-	dB

**ELECTRICAL CHARACTERISTICS**

( $V_{CC} = 1.4V \pm 5\%$ ,  $f_{IN} (2MIX) = 21.4MHz$ ,  $f_{DEV} = \pm 4.8kHz$ ,  $f_{MOD} = 800Hz$ ,  $T_a = 25^\circ C$ ,  $FIL\_VAR = "H"$ , unless otherwise specified)

Characteristic	Symbol	Test Conditions	Min.	Typ.	Max.	Unit
Data shaping output duty	DR	$V_{IN} (2MIX) = 500\mu Vrms$	40	50	60	%
RSSI output voltage	$V_{RSSI}$	$V_{IN} (2MIX) = 1mVrms$	0.49	0.7	0.91	V
RSSI output resistance	$R_{RSSI}$	–	90	100	110	k $\Omega$
$V_{CC2}$ operating range	$V_{CC2}$	$V_{IN} (IF) = 630\mu Vrms$	2	–	6	V
Audio Output Level	$V_{AUDIO}$	$V_{IN} (LIM) = 500\mu Vrms$	0.9	1.25	1.5	V
DC Output voltage	$V_{DC}$	$V_{IN} (LIM) = 500\mu Vrms$	0.9	1.1	1.3	V

APPLICATION CIRCUIT

