

DEVICE PERFORMANCE SPECIFICATION

Revision 3.0 MTD/PS-0307

March 19, 2007

www.DataSheet4U.com

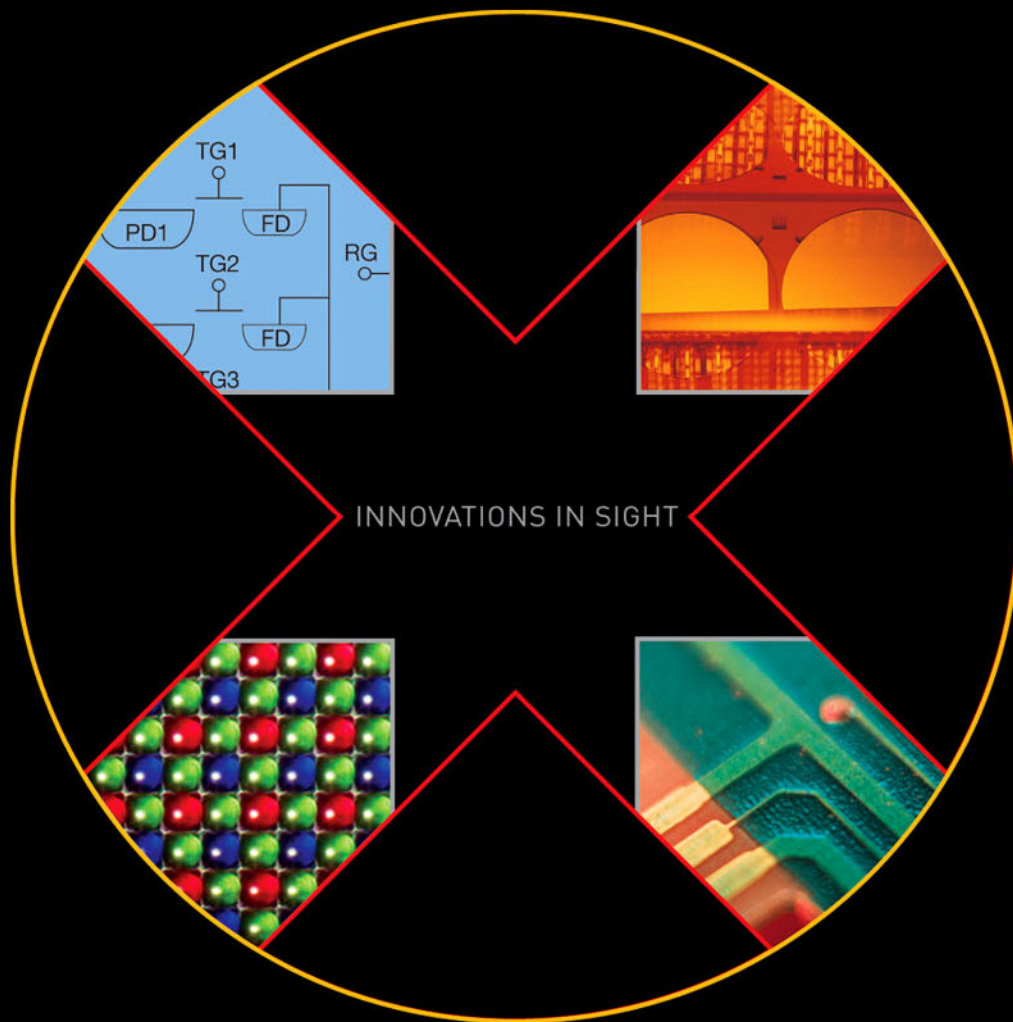

KODAK KAI-2093 IMAGE SENSOR

1920 (H) X 1080 (V) INTERLINE CCD IMAGE SENSOR

Kodak
Image Sensor Solutions

www.DataSheet4U.com

TABLE OF CONTENTS

Summary Specification 4

 Description 4

 Features..... 4

 Applications 4

Ordering Information 5

Device Description 6

 Architecture 6

 Pin Description and Physical Orientation..... 7

Imaging Performance 8

 Typical Operational Conditions 8

 Optical Specifications..... 8

 CCD Specifications 8

 Output Amplifier Specifications 9

 General Specifications 9

Typical Performance Curves..... 10

 Monochrome Quantum Efficiency 10

 Monochrome with Microlens Angular Quantum Efficiency..... 10

 Color with Lenslet Quantum Efficiency 11

 Frame Rates 12

Defect Definitions..... 13

 Operational Conditions..... 13

 Specifications 13

 Defect Zones..... 13

 Defect Classes..... 13

Operation..... 14

 Absolute Maximum Ratings 14

 DC Bias Operating Conditions 14

 AC Operating Conditions 14

 Clock Capacitance..... 15

 Operation Notes 16

 Progressive and Interlaced Timing..... 16

 Single Output Mode 16

 Dual Output Mode..... 16

 Exposure Control..... 17

 Dark References..... 17

 Connections to the Image Sensor..... 17

Timing..... 18

 Requirements and Characteristics 18

 Frame Timing 19

 Frame Timing – Progressive Scan..... 19

 Vertical Clock Edge Alignment 20

 Frame Timing – Field Integration Mode 21

 Frame Timing – Frame Integration Mode 22

 Line Timing 23

 Electronic Shutter Timing..... 24

Storage and Handling 25

 Storage Conditions 25

 ESD 25

Cover Glass Care and Cleanliness	25
Environmental Exposure.....	25
Soldering Recommendations	25
Mechanical Drawings.....	26
Completed Assembly	26
Cover Glass.....	28
Clear Cover Glass.....	28
Quartz Cover Glass with AR Coatings.....	29
Glass Transmission.....	30
Quality Assurance and Reliability	31
Quality Strategy	31
Replacement	31
Liability of the Supplier	31
Liability of the Customer.....	31
Reliability	31
Test Data Retention.....	31
Mechanical.....	31
Warning: Life Support Applications Policy	31
Revision Changes.....	32

TABLE OF FIGURES

Figure 1: Sensor Architecture	6
Figure 2: Package Pin Designations - Top View	7
Figure 4: Quantum Efficiency Spectrum for Monochrome Sensors.....	10
Figure 5: Angular Dependence of Quantum Efficiency	10
Figure 6: Quantum Efficiency Spectrum for Color Filter Array Sensors.....	11
Figure 7: Color Filter Array Pattern	11
Figure 3: Progressive Frame Rate vs. HCCD Clock Frequency.....	12
Figure 8: Defect Zones.....	13
Figure 9: Progressive Frame Timing	19
Figure 10: Ideal Vertical Clock Edge Position.....	20
Figure 11: Interlaced Frame Timing - Field Integration Mode	21
Figure 12: Interlaced Frame Timing - Frame Integration Mode.....	22
Figure 13: Line Timing.....	23
Figure 14: Electronic Shutter Timing Diagram.....	24
Figure 15: Completed Assembly (1 of 2)	26
Figure 16: Completed Assembly (2 of 2)	27
Figure 17: Clear Cover Glass Drawing.....	28
Figure 18: Quartz Cover Glass with AR Coating Drawing.....	29
Figure 19: Cover Glass Transmission	30

SUMMARY SPECIFICATION

KODAK KAI-2093 IMAGE SENSOR

1920 (H) X 1080 (V) PROGRESSIVE SCAN INTERLINE CCD IMAGE SENSOR

DESCRIPTION

The KODAK KAI-2093 Image Sensor is a high-performance multi-megapixel image sensor designed for a wide range of medical imaging and machine vision applications.

The 7.4 μm square pixels with microlenses provide high sensitivity and the large full well capacity results in high dynamic range. The split horizontal register offers a choice of single or dual output allowing either 15 or 30 frame per second (fps). The architecture allows for either progressive scan or interlaced readout. The imager features 5V clocking to facilitate camera design. The vertical overflow drain structure provides antiblooming protection, and enables electronic shuttering for precise exposure control.

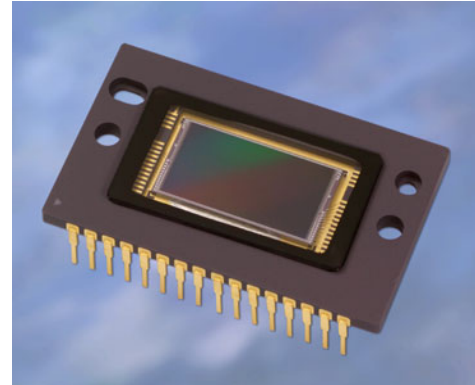

FEATURES

- Progressive scan (non-interlaced)
- HCCD and output amplifier capable of 40 MHz operation
- 5 V HCCD clocking
- Single or dual video output operation
- 28 light shielded reference columns per output
- Only 2 vertical CCD clocks and 2 horizontal CCD clocks
- Electronic shutter
- Low Dark Current
- Antiblooming protection

APPLICATIONS

- Industrial Imaging
- Scientific Imaging

Parameter	Typical Value
Architecture	Interline CCD, Progressive Scan or Interlaced Readout
Total Number of Pixels	1984 (H) x 1092 (V)
Number of Effective Pixels	1928 (H) x 1084(V)
Number of Active Pixels	1920 (H) x 1080 (V)
Pixel Size	7.4 μm (H) x 7.4 μm (V)
Active Image Size	14.208 mm (H) x 7.992 mm (V) 16.3 mm (diagonal)
Aspect Ratio	16:9
Number of Outputs	1 or 2
Saturation Signal	40,000 electrons
Output Sensitivity	14 μV /electron
Quantum Efficiency KAI-2093-ABA (490 nm)	40%
Quantum Efficiency KAI-2093-CBA R(620 nm), G(540nm), B(460nm)	37%, 34%, 30%
Total Noise	40 electrons rms
Dark Current (Typical)	<0.5 nA/cm ²
Dynamic Range	60 dB
Blooming Suppression	100 X
Smear	<0.03%
Image Lag	<10 electrons
Frame Rate	Single Output, 20 MHz 9 fps Single Output, 35 MHz 15 fps Dual Outputs, 20 MHz 17 fps Dual Outputs, 37 MHz 30 fps
Maximum Data Rate	40 MHz/Channel (2 channels)
Package	32 pin cerDIP
Cover Glass	Clear Glass or Quartz Glass with AR Coating, 2 sides

Parameters above are specified at T = 40° C unless otherwise noted.

ORDERING INFORMATION

Catalog Number	Product Name	Description	Marking Code
2H4736	KAI- 2093-AAA-CP-AE	Monochrome, No Microlens, CERDIP Package (sidebrazed), Taped Clear Cover Glass (no coatings), Engineering Sample	KAI-2093 Serial Number
2H4617	KAI- 2093-AAA-CP-BA	Monochrome, No Microlens, CERDIP Package (sidebrazed), Taped Clear Cover Glass (no coatings), Standard Grade	
2H4728	KAI- 2093-ABA-CB-AE	Monochrome, Telecentric Microlens, CERDIP Package (sidebrazed), Clear Cover Glass (no coatings), Engineering Sample	KAI-2093M Serial Number
4H0174	KAI- 2093-ABA-CB-B1	Monochrome, Telecentric Microlens, CERDIP Package (sidebrazed), Clear Cover Glass (no coatings), Grade 1	
2H4725	KAI- 2093-ABA-CB-B2	Monochrome, Telecentric Microlens, CERDIP Package (sidebrazed), Clear Cover Glass (no coatings), Grade 2	
2H4923	KAI- 2093-ABA-CK-AE	Monochrome, Telecentric Microlens, CERDIP Package (sidebrazed), Quartz Cover Glass with AR coating (both sides), Engineering Sample	
2H4920	KAI- 2093-ABA-CK-BA	Monochrome, Telecentric Microlens, CERDIP Package (sidebrazed), Quartz Cover Glass with AR coating (both sides), Standard Grade	
2H4618	KAI- 2093-ABA-CP-AE	Monochrome, Telecentric Microlens, CERDIP Package (sidebrazed), Taped Clear Cover Glass (no coatings), Engineering Sample	
2H4616	KAI- 2093-ABA-CP-BA	Monochrome, Telecentric Microlens, CERDIP Package (sidebrazed), Taped Clear Cover Glass (no coatings), Standard Grade	
4H0137	KAI- 2093-CBA-CB-AE	Color (Bayer RGB), Telecentric Microlens, CERDIP Package (sidebrazed), Clear Cover Glass (no coatings), Engineering Sample	KAI-2093CM Serial Number
4H0136	KAI- 2093-CBA-CB-BA	Color (Bayer RGB), Telecentric Microlens, CERDIP Package (sidebrazed), Clear Cover Glass (no coatings), Standard Grade	
4H0705	KEK-4H0705-KAI-2093-10-40	Evaluation Board, 10 Bit, 40 MHz (Complete Kit)	n/a
4H0706	KEK-4H0706-KAI-2093-12-20	Evaluation Board, 12 Bit, 20 MHz (Complete Kit)	n/a

Please see the User's Manual (MTD/PS-0715) for information on the Evaluation Kit for this part.

Please see ISS Application Note "Product Naming Convention" (MTD/PS-0892) for a full description of naming convention used for KODAK image sensors.

Address all inquiries and purchase orders to:

Image Sensor Solutions
Eastman Kodak Company
Rochester, New York 14650-2010

Phone: (585) 722-4385
Fax: (585) 477-4947
E-mail: imagers@kodak.com

Kodak reserves the right to change any information contained herein without notice. All information furnished by Kodak is believed to be accurate.

DEVICE DESCRIPTION

ARCHITECTURE

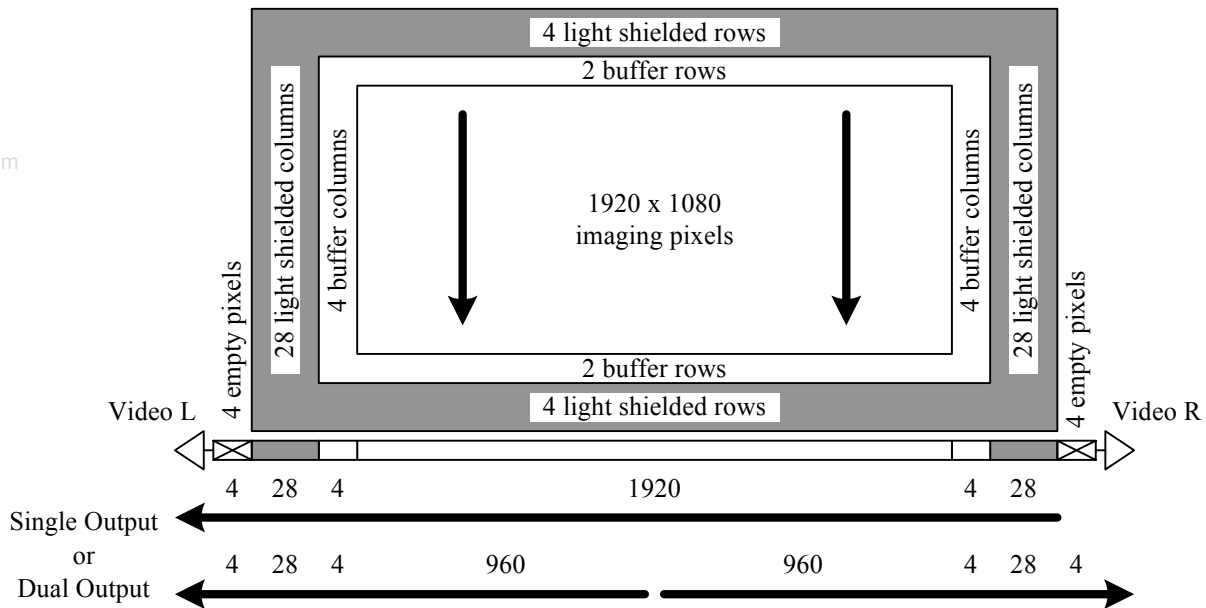

Figure 1: Sensor Architecture

There are 4 light shielded rows followed by 1084 photoactive rows and finally 4 more light shielded rows. The first and last 2 photoactive rows are buffer rows giving a total of 1080 lines of image data.

In the single output mode all pixels are clocked out of the Video L output in the lower left corner of the sensor. The first four empty pixels of each line do not receive charge from the vertical shift register. The next 28 pixels receive charge from the left light shielded edge followed by 1928 photoactive pixels and finally 28 more light shielded pixels from the right edge of the sensor. The first and last 4 photoactive pixels are buffer pixels giving a total of 1920 pixels of image data.

In the dual output mode the clocking of the right half of the horizontal CCD is reversed. The left half of the image is clocked out Video L and the right half of the image is clocked out Video R. Each row consists of 4 empty pixels followed by 28 light shielded pixels followed by 964 photoactive pixels. When reconstructing the image, data from Video R will have to be reversed in a line buffer and appended to the Video L data.

PIN DESCRIPTION AND PHYSICAL ORIENTATION

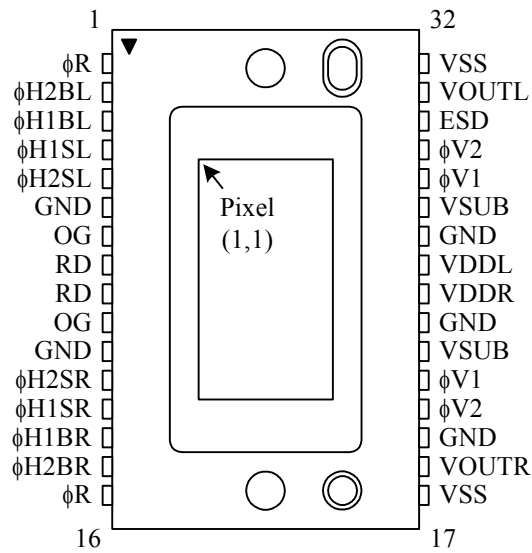

Figure 2: Package Pin Designations - Top View

Pin	Label
1	ϕR
2	$\phi H2BL$
3	$\phi H1BL$
4	$\phi H1SL$
5	$\phi H2SL$
6	GND
7	OG
8	RD
9	RD
10	OG
11	GND
12	$\phi H2SR$
13	$\phi H1SR$
14	$\phi H1BR$
15	$\phi H2BR$
16	ϕR

Pin	Label
17	VSS
18	VOUTR
19	GND
20	$\phi V2O$
21	$\phi V1$
22	VSUB
23	GND
24	VDDR
25	VDDL
26	GND
27	VSUB
28	$\phi V1$
29	$\phi V2E$
30	ESD
31	VOUTL
32	VSS

The horizontal shift register is on the side of the sensor parallel to the row of pins 1 through 16. In single output mode the pixel closest to pin 1 will be read out first through Video L, the pixel closest to pin 17 will be read out last. In dual output mode the pixel closest to pin 16 will be read out first through Video R.

IMAGING PERFORMANCE

TYPICAL OPERATIONAL CONDITIONS

Description	Condition
Temperature	40 °C
Integration Time	33 ms (40 MHz HCCD frequency, 30 fps frame rate)
Operation	Nominal voltages and timing
Image defects are excluded from performance tests.	

www.DataSheet4U.com

OPTICAL SPECIFICATIONS

Symbol	Description	Min	Nom	Max	Unit	Notes
QE_{max}	Peak Quantum Efficiency	33	36		%	1
λQE	Peak Quantum Efficiency Wavelength		490		nm	1
QE(540)	Quantum Efficiency at 540nm	31	33		%	1
θQE_h	Microlens Acceptance Angle (horizontal)	± 12	± 13		degrees	2
θQE_v	Microlens Acceptance Angle (vertical)	± 25	± 30		degrees	2
NL	Maximum Photoresponse Nonlinearity		2		%	3, 4
ΔG	Maximum Gain Difference Between Outputs		10		%	3, 4
ΔNL	Maximum Signal Error caused by Nonlinearity Differences		1		%	3, 4

Notes:

1. For monochrome sensors.
2. Value is the angular range of incident light for which the quantum efficiency is at least 50% of QE_{max} at a wavelength of λQE . Angles are measured with respect to the sensor surface normal in a plane parallel to the horizontal axis (θQE_h) or in a plane parallel to the vertical axis (θQE_v).
3. Value is over the range of 10% to 90% of photodiode saturation.
4. Value is for the sensor operated without binning.

CCD SPECIFICATIONS

Symbol	Description	Min	Nom	Max	Unit	Notes
VNe	Vertical CCD Charge Capacity	45	50		ke^-	
HNe	Horizontal CCD Charge Capacity		100		ke^-	
PNe	Photodiode Charge Capacity	35	40		ke^-	1
I_d	Dark Current		0.3	1.0	nA/cm^2	
Lag	Image Lag		< 10	50	e^-	2
Xab	Antiblooming factor	100	300			3, 4, 5, 6
Smr	Vertical Smear		-75	-72	dB	3, 4

Notes:

1. This value depends on the substrate voltage setting. Higher photodiode saturation charge capacities will lower the antiblooming specification. Substrate voltage will be specified with each part for nominal photodiode charge capacity.
2. This is the first field decay lag at 70% saturation. Measured by strobe illumination of the device at 70% of photodiode saturation, and then measuring the subsequent frame's average pixel output in the dark.
3. Measured with a spot size of 100 vertical pixels.
4. Measured with F/4 imaging optics and continuous green illumination centered at 550 nm.
5. A blooming condition is defined as when the spot size doubles in size.
6. Antiblooming factor is the light intensity which causes blooming divided by the light intensity which first saturates the photodiodes.

OUTPUT AMPLIFIER SPECIFICATIONS

Symbol	Description	Nominal	Unit	Notes
P_d	Power Dissipation	120	mW	1
F_{-3dB}	Bandwidth	140	MHz	1
C_L	Max Off-chip Load	10	pF	2
A_v	Gain	0.75		1
$\Delta V/\Delta N$	Sensitivity	14	$\mu V/e^-$	1

Notes:

1. For a 5 mA output load on each amplifier. Per amplifier.
2. With total output load capacitance of $C_L = 10$ pF between the outputs and AC ground.

GENERAL SPECIFICATIONS

Symbol	Description	Nominal	Unit	Notes
n_{e-T}	Total Noise	40	$e^- rms$	1
DR	Dynamic Range	60	dB	2

Notes:

1. Includes system electronics noise, dark pattern noise and dark current shot noise at 20 MHz.
2. Uses $20\text{LOG}(PNe/n_{e-T})$

TYPICAL PERFORMANCE CURVES

MONOCHROME QUANTUM EFFICIENCY

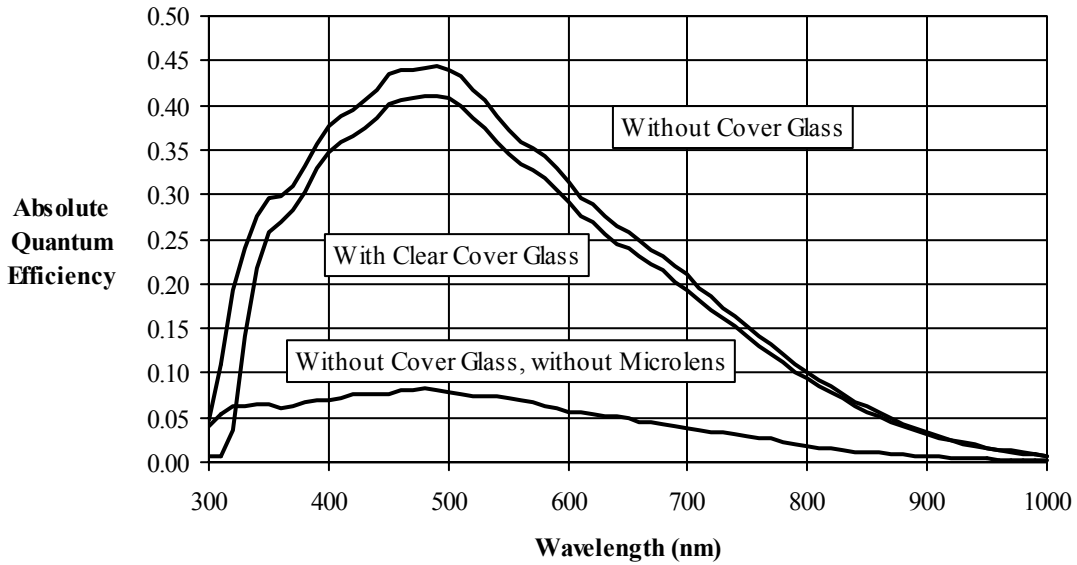

Figure 3: Quantum Efficiency Spectrum for Monochrome Sensors

MONOCHROME WITH MICROLENS ANGULAR QUANTUM EFFICIENCY

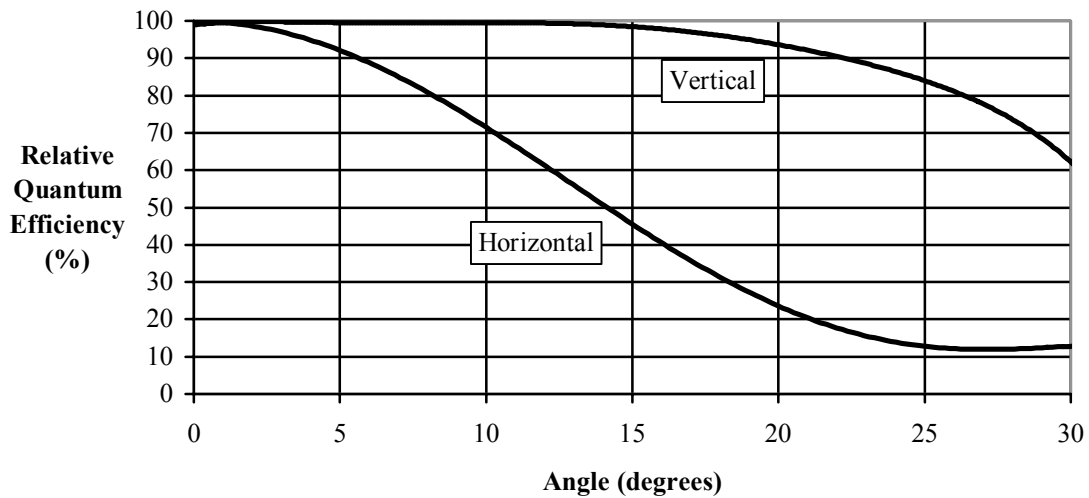

Figure 4: Angular Dependence of Quantum Efficiency

For the curve marked "Horizontal", the incident light angle is varied in a plane parallel to the HCCD.
For the curve marked "Vertical", the incident light angle is varied in a plane parallel to the VCCD.

COLOR WITH LENSLET QUANTUM EFFICIENCY

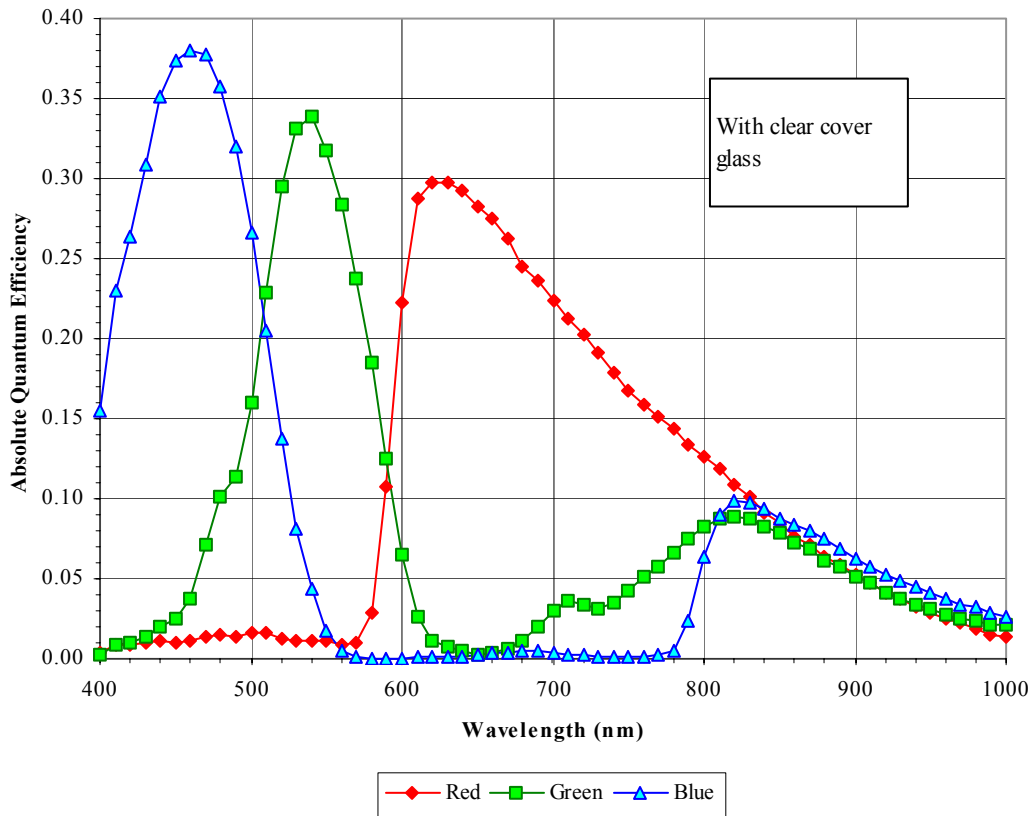

Figure 5: Quantum Efficiency Spectrum for Color Filter Array Sensors

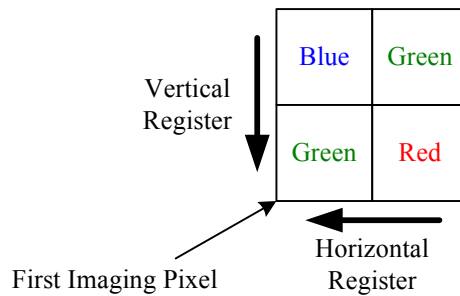

Figure 6: Color Filter Array Pattern

FRAME RATES

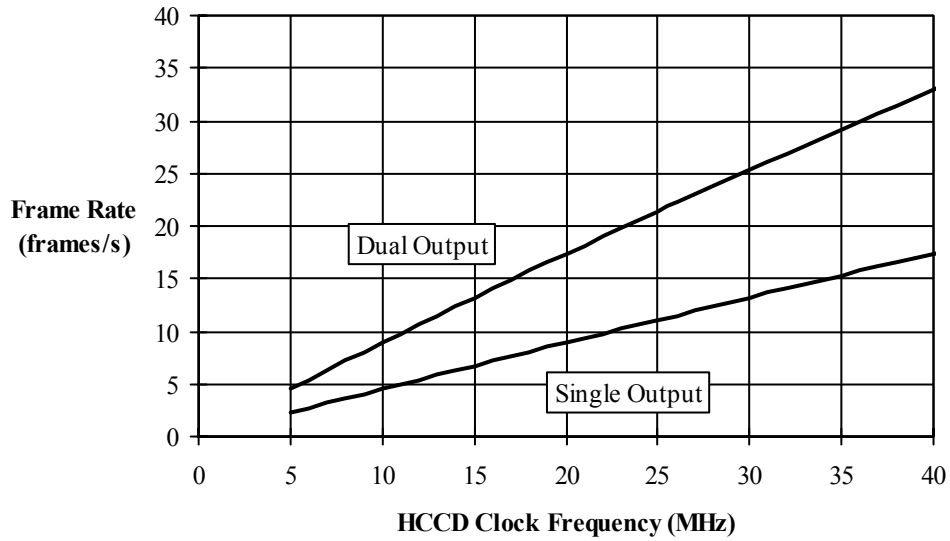

Figure 7: Progressive Frame Rate vs. HCCD Clock Frequency

DEFECT DEFINITIONS

OPERATIONAL CONDITIONS

Description	Condition
Temperature	40 °C
Integration Time	33 ms (40 MHz HCCD frequency, no binning, 30 fps frame rate)
Light source	Continuous green illumination centered at 550 nm
Operation	Nominal voltages and timing

SPECIFICATIONS

Name	Definition
Major Defective Pixel	A pixel whose signal deviates by more than 25 mV from the mean value of all active pixels under dark field condition or by more than 15% from the mean value of all active pixels under uniform illumination of 80% of saturation
Minor Defective Pixel	A pixel whose signal deviates by more than 8 mV from the mean value of all active pixels under dark field conditions
Cluster Defect	A group of 2 to 10 contiguous major defective pixels with a width no wider than 2 defective pixels
Column Defect	A group of more than 10 contiguous major defective pixels along a single column

Notes:

1. There will be at least two non-defective pixels separating any two major defective pixels
2. Buffer and dark reference pixels are not used for defect tests

DEFECT ZONES

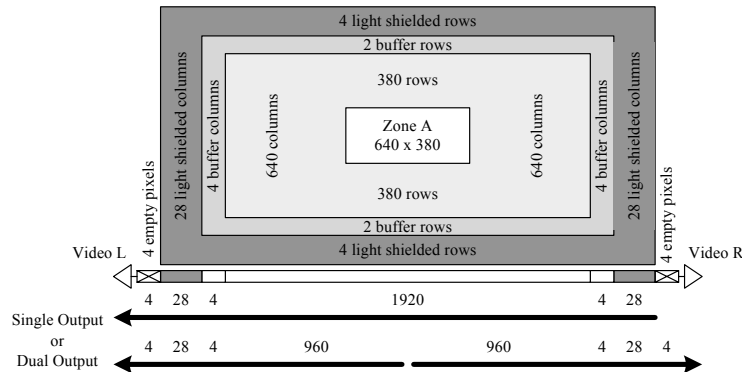

Figure 8: Defect Zones

DEFECT CLASSES

KAI-2093-ABA-CB-B1

Maximum Number of Defects							
Major Point		Minor Point		Cluster		Column	
Within Zone A	Outside Zone A	Within Zone A	Outside Zone A	Within Zone A	Outside Zone A	Within Zone A	Outside Zone A
3	10	20	100	0	4	0	0

All Other Part Numbers

Zone A is not used

Maximum Number of Defects			
Major Point	Minor Point	Cluster	Column
10	100	4	0

OPERATION

ABSOLUTE MAXIMUM RATINGS

		Min	Max	Unit	Notes
Temperature	Operation without damage	-50	70	°C	
Voltage between pins	VSUB to GND	8	20	V	1
	VDD, OG to GND	0	17	V	
	VRD to GND	0	14	V	
	$\phi V1$ to $\phi V2$	-20	20	V	
	$\phi H1$ to $\phi H2$	-15	15	V	
	ϕR to GND	-15	15	V	
	$\phi H1, \phi H2$ to OG	-15	15	V	
	$\phi H1, \phi H2$ to $\phi V1, \phi V2$	-15	15	V	
Current	Video Output Bias Current	0	10	mA	2

Notes:

- For electronic shuttering VSUB may be pulsed to 50 V for up to 10 μ s.
- Total for both outputs. Current is 5 mA for each output. Note that the current bias effects the amplifier bandwidth

DC BIAS OPERATING CONDITIONS

Symbol	Description	Min	Nom	Max	Unit	Notes
OG	Output Gate	-3.0	-2.5	-2.0	V	
VRD	Reset Drain	10.0	10.5	11.0	V	
VSS	Output Amplifier Return	0.0	0.7	1.0	V	
VDD	Output Amplifier Supply	14.5	15.0	15.5	V	
GND	Ground, P-well		0.0		V	
VSUB	Substrate	8.0	TBD	17.0	V	
VESD	ESD Protection	-8.0	-7.0	-6.0	V	1

Notes:

- VESD must be at least 1 V more negative than $\phi H1L$ and $\phi H2L$ during sensor operation AND during camera power turn on.

AC OPERATING CONDITIONS

Symbol	Description	Min	Nom	Max	Unit	Notes
$\phi V2H$	Vertical CCD Clock High	7.5	8.0	8.5	V	
$\phi V1M, \phi V2M$	Vertical CCD Clocks Midlevel	-1.6	-1.5	-1.4	V	
$\phi V1L, \phi V2L$	Vertical CCD Clocks Low	-9.5	-9.0	-8.5	V	
$\phi H1H, \phi H2H$	Horizontal CCD Clocks High	0.5	1.0	2.0	V	
$\phi H1L, \phi H2L$	Horizontal CCD Clocks Low	-5.0	-4.0	-3.8	V	
ϕR	Reset Clock Amplitude		5.0		V	
ϕRL	Reset Clock Low	-4.0	-3.5	-3.0	V	
VShutter	Electronic Shutter Voltage	44	48	52	V	

CLOCK CAPACITANCE

Clocks	Capacitance	Units	Notes
$\phi V1$ to GND	25	nF	1
$\phi V2$ to GND	25	nF	1
$\phi V1$ to $\phi V2$	5	nF	
$\phi H1S$ to GND	45	pF	2
$\phi H2S$ to GND	38	pF	2
$\phi H1B$ to GND	21	pF	2
$\phi H2B$ to GND	20	pF	2
$\phi H2B$ to $\phi H1S$	10	pF	2
$\phi H1B$ to $\phi H1S$	10	pF	2
$\phi H2B$ to $\phi H2S$	10	pF	2
$\phi H1B$ to $\phi H2S$	10	pF	2
ϕR to GND	10	pF	

Notes:

- Gate capacitance to GND is voltage dependent. Value is for nominal VCCD clock voltages.
- For nominal HCCD clock voltages, total capacitance for one half (H1SR only or H1SL only).

OPERATION NOTES

Progressive and Interlaced Timing

Progressive and interlaced output modes are achieved by the applying the proper waveforms to the vertical clock input pins $\phi V1$, $\phi V2E$ and $\phi V2O$. For progressive output, $\phi V2 = \phi V2E = \phi V2O$, with each of the 1092 lines read out individually using the timing in Figure 9.

For interlaced output, there are two modes, field integration mode and frame integration mode. In both modes, $1092/2 = 546$ lines are read in each frame readout, with one even frame readout and one odd frame readout necessary for a complete frame. Field integration mode bins together alternate lines, and the timing is shown in Figure 11. As with progressive readout, $\phi V2 = \phi V2E = \phi V2O$.

Frame integration mode reads out the photodiodes of the even and odd lines separately, and the timing is shown in Figure 12. In this case, $\phi V2E$ and $\phi V2O$ are clocked individually.

Single Output Mode

When operating the sensor in single output mode all pixels of the image sensor will be shifted out the Video L output (pin 31). To conserve power and lower heat generation the output amplifier for Video R may be turned off by connecting VDDR (pin 24) and VOUTR (pin 18) to GND (zero volts).

The $\phi H1$ timing from the timing diagrams should be applied to $\phi H1SL$, $\phi H1BL$, $\phi H1SR$, $\phi H2BR$, and the $\phi H2$ timing should be applied to $\phi H2SL$, $\phi H2BL$, $\phi H2SR$, $\phi H1BR$. In other words, the clock driver generating the $\phi H1$ timing should be connected to pins 4, 3, 13, and 15. The clock driver generating the $\phi H2$ timing should be connected to pins 2, 5, 12, and 14.

The horizontal CCD should be clocked for 4 empty pixels plus 28 light shielded pixels plus 1928 photoactive pixels plus 28 light shielded pixels for a total of 1988 pixels.

Dual Output Mode

In dual output mode the connections to the $\phi H1BR$ and $\phi H2BR$ pins are swapped from the single output mode to change the direction of charge transfer of the right side horizontal shift register. In dual output mode both VDDL and VDDR (pins 25, 24) should be connected to 15 V.

The $\phi H1$ timing from the timing diagrams should be applied to $\phi H1SL$, $\phi H1BL$, $\phi H1SR$, $\phi H1BR$, and the $\phi H2$ timing should be applied to $\phi H2SL$, $\phi H2BL$, $\phi H2SR$, $\phi H2BR$. The clock driver generating the $\phi H1$ timing should be connected to pins 4, 3, 13, and 14. The clock driver generating the $\phi H2$ timing should be connected to pins 2, 5, 12, and 15.

The horizontal CCD should be clocked for 4 empty pixels plus 28 light shielded pixels plus 964 photoactive pixels for a total of 996 pixels.

If the camera is to have the option of dual or single output mode, the clock driver signals sent to $\phi H1BR$ and $\phi H2BR$ may be swapped by using a relay. Another alternative is to have two extra clock drivers for $\phi H1BR$ and $\phi H2BR$ and invert the signals in the timing logic generator. If two extra clock drivers are used, care must be taken to ensure the rising and falling edges of the $\phi H1BR$ and $\phi H2BR$ clocks occur at the same time (within 3 ns) as the other HCCD clocks.

Exposure Control

If the sensor is operated at 20 MHz horizontal CCD frequency then the frame rate will be 9 fps and the integration time will be 1/9 s or 111 ms. To achieve shorter integration times, the electronic shutter option may be used by applying a pulse to the substrate (pins 22 and 27). The time between the falling edge of the substrate pulse and the falling edge of the transition of the $\phi V2$ clock from $\phi V2H$ to $\phi V2M$ is defined as the integration time. The substrate pulse and integration time are shown in Figure 14.

Integration times longer than one frame time (111 ms in this example) do not require use of the electronic shutter. Without the electronic shutter the integration time is defined as the time between when the $\phi V2$ clock is at the $\phi V2H$ level of 9.5 V (when the $\phi V2$ clock is at the $\phi V2H$ level charge collected in the photodiodes is transferred to the vertical shift register). To extend the integration time, increase the time between each $\phi V2H$ level of the $\phi V2$ clock. While the photodiodes are integrating photoelectrons the vertical and horizontal shift registers should be continuously clocked to prevent the collection of dark current in the vertical shift register. This is most easily done by increasing the number of lines read out of the image sensor. For example, to double the integration time read out 2184 lines instead of 1092 lines (but remember only the first 1092 lines will contain image data).

Depending on the image quality desired and temperature of the sensor, integration times longer than one second may require the sensor to be cooled to control dark current. The output amplifiers will also generate a non-uniform dark current pattern near the bottom corners of the sensor. This can be reduced at long integration times by only turning on VDD to each amplifier during image readout. If the vertical and horizontal shift registers are also stopped during integration time, the dark current in the shift registers should be flushed out completely before transferring charge from the photodiodes to the vertical shift register.

Dark References

There are 28 light shielded columns at the left and right side of the image sensor. The first and last two light shielded columns should not be used as a dark reference due to some light leakage under the edges of the light shielding. Only the center 24 columns should be used for dark reference line clamping. There are 4 light shielded rows at the top and bottom of the image sensor. Only the center two light shielded rows should be used as a dark reference.

Connections to the Image Sensor

The reset clock signal operates at the pixel frequency. The traces on the circuit board to the reset clock pins should be kept short and of equal length to ensure that the reset pulse arrives at each pin simultaneously. The circuit board traces to the horizontal clock pins should also be placed to ensure that the clock edges arrive at each pin simultaneously. If reset pulses and the horizontal clock edges are misaligned the noise performance of the sensor will be degraded and balancing the offset and gain of the two output amplifiers will be difficult.

The bias voltages on OG, RD, VSS and VDD should be well filtered with capacitors placed as close to the pins as possible. Noise on the video outputs will be most strongly effected by noise on VSS, VDD, GND, and VSUB. If the electronic shutter is not used then a filtering capacitor should also be placed on VSUB. If the electronic shutter is used, the VSUB voltage should be kept as clean and noise free as possible.

The voltage on VSS may be set by using the 0.6 to 0.7 volt drop across a diode. Place the diode from VSS to GND. To disable one of the output amplifiers connect VDD to GND, do not let VDD float.

The ESD voltage must reach its operating point before any of the horizontal clocks reach their low level. If any pin on the sensor comes within 1 V of the ESD pin the electrostatic damage protection circuit will become active and will not turn off until all voltages are powered down. Operating the sensor with the ESD protection circuit active may damage the sensor.

TIMING

REQUIREMENTS AND CHARACTERISTICS

Symbol	Description	Min	Nom	Max	Unit	Notes
T_{HD}	HCCD Delay	1.3	1.5	10.0	μs	
T_{VCCD}	VCCD Transfer time	1.3	1.5		μs	
T_{V3rd}	Photodiode Transfer time	8.0	12.0	15.0	μs	
T_{3P}	VCCD Pedestal time	20.0	25.0	50.0	μs	
T_{3D}	VCCD Delay	15.0	20.0	100.0	μs	
T_R	Reset Pulse time	5.0	10.0		ns	
T_S	Shutter Pulse time	3.0	5.0	10.0	μs	
T_{SD}	Shutter Pulse delay	1.0	1.6	10.0	μs	
T_H	HCCD Clock Period	25.0	50.0	200.0	ns	
T_{VR}	VCCD rise/fall time	0.0	0.1	1.0	μs	
T_{VE}	Vertical Clock Edge Alignment	0.0		100.0	ns	

FRAME TIMING

Frame Timing – Progressive Scan

Progressive Frame Timing

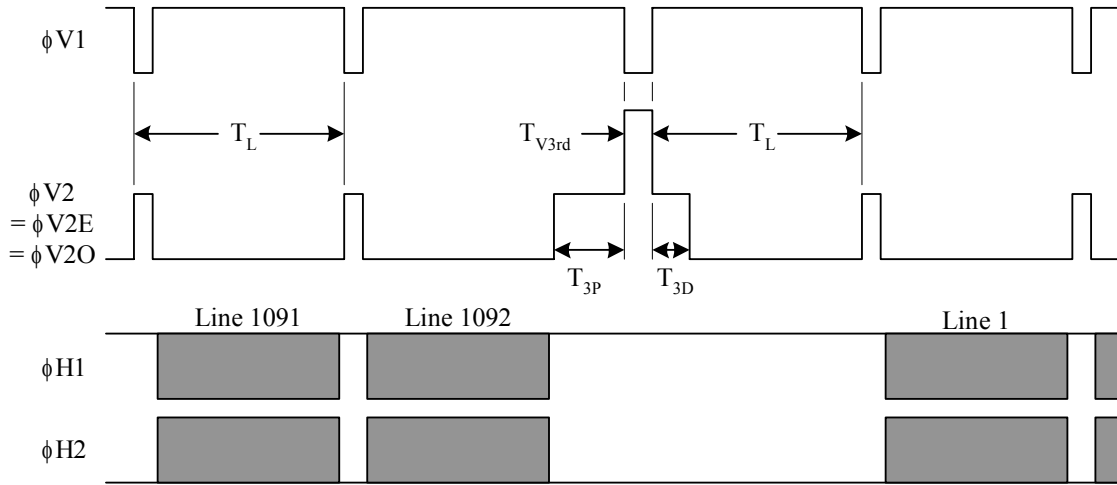

Frame Timing for Vertical Binning by 2

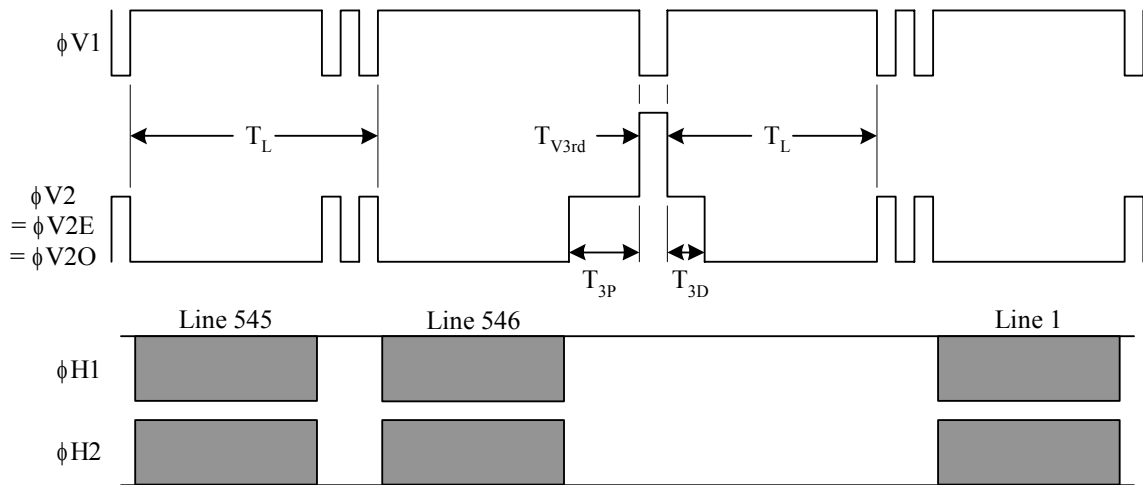

Figure 9: Progressive Frame Timing

Vertical Clock Edge Alignment

KAI-2093 Vertical Clock Timing - Edge Position

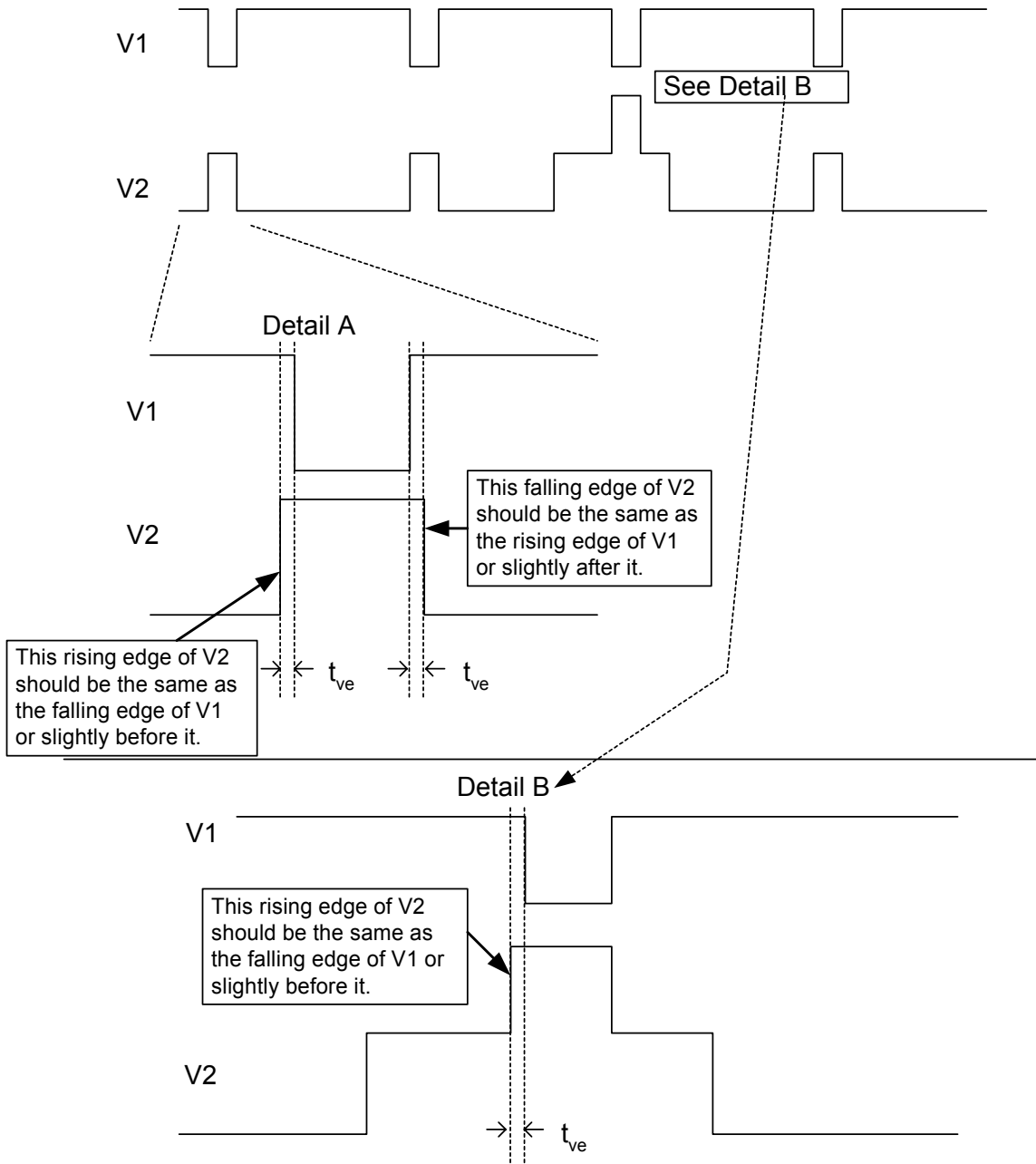
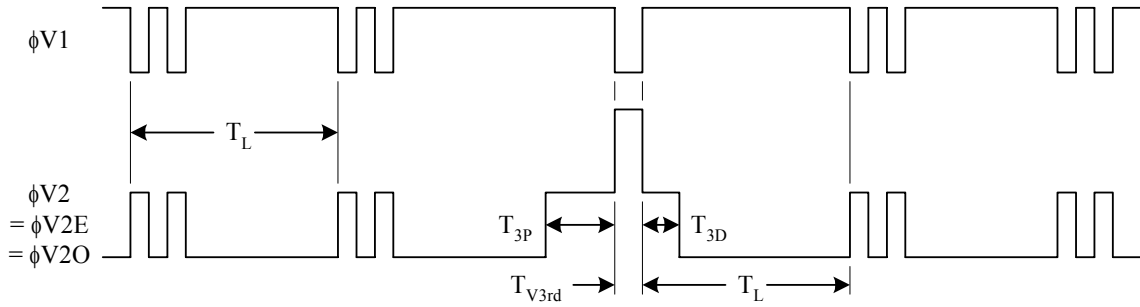

Figure 10: Ideal Vertical Clock Edge Position

Frame Timing – Field Integration Mode

Interlaced Frame Timing - Field Integration Mode - Even Field Readout



Interlaced Frame Timing - Field Integration Mode - Odd Field Readout

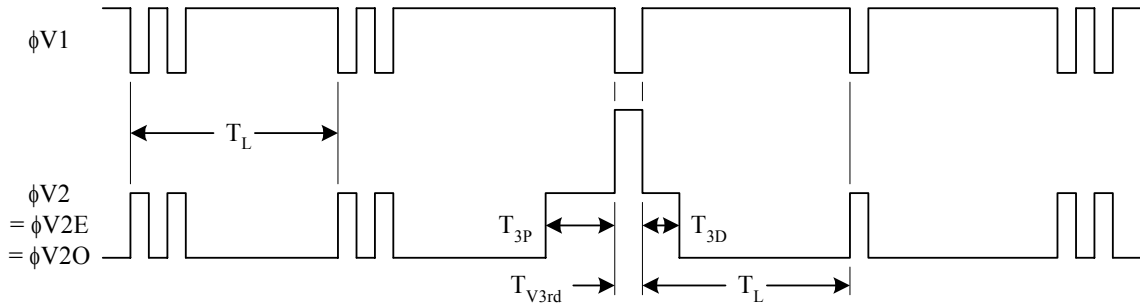
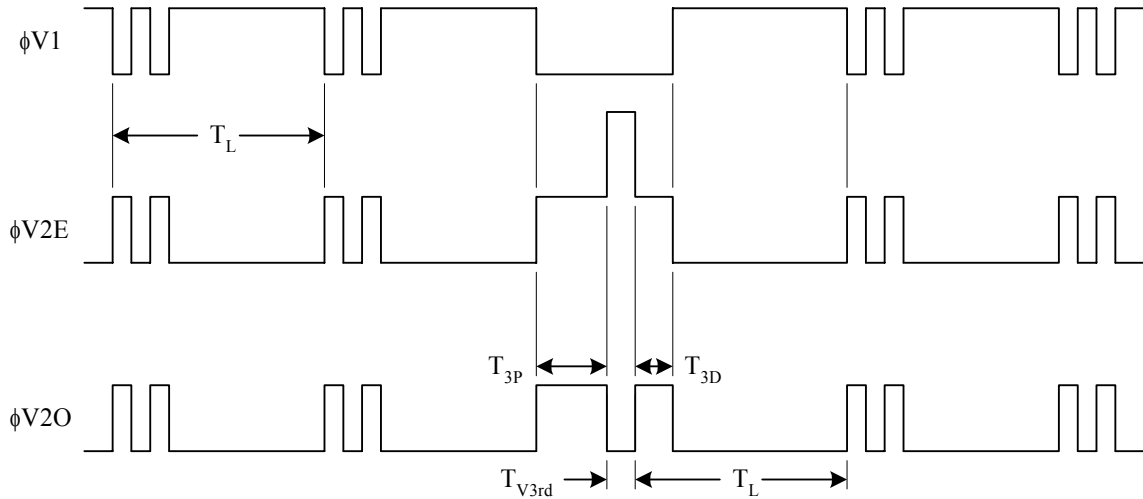

Figure 11: Interlaced Frame Timing - Field Integration Mode

Frame Timing – Frame Integration Mode

Interlaced Frame Timing - Frame Integration Mode - Even Field Readout



Interlaced Frame Timing - Frame Integration Mode - Odd Field Readout

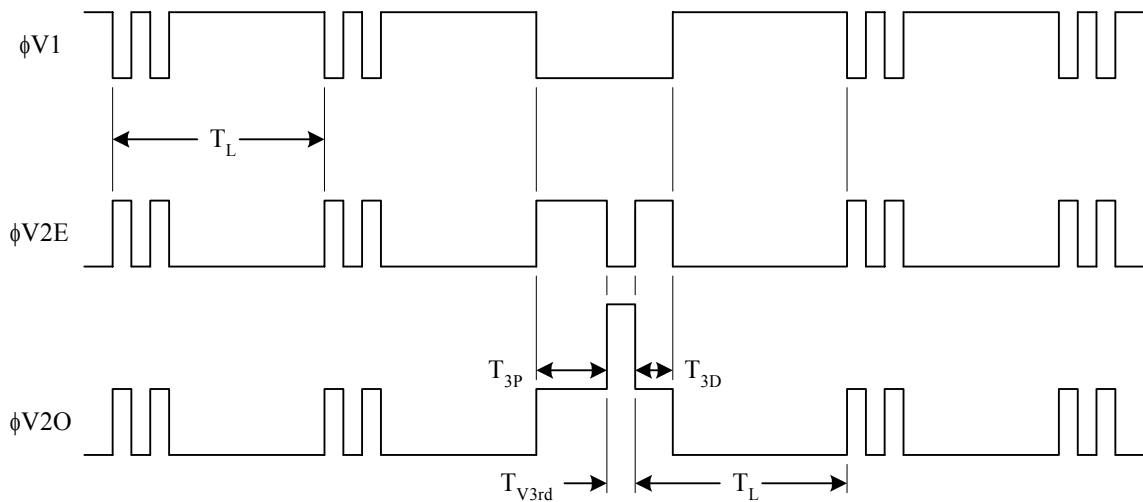
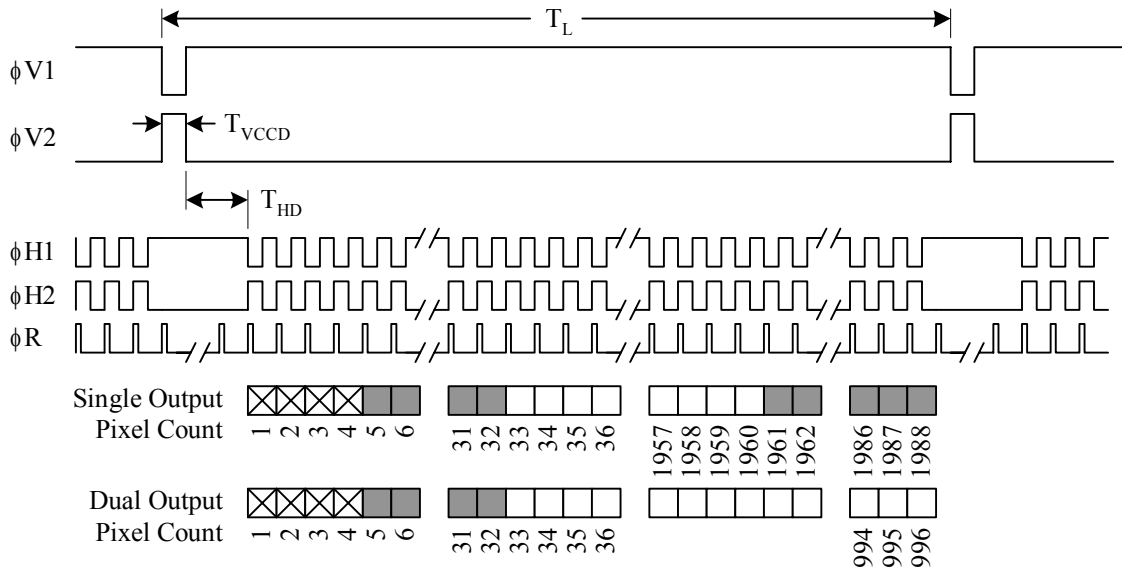

Figure 12: Interlaced Frame Timing - Frame Integration Mode

LINE TIMING

Progressive Line Timing



**Interlaced Line Timing
and Line Timing for Vertical Binning by Two**

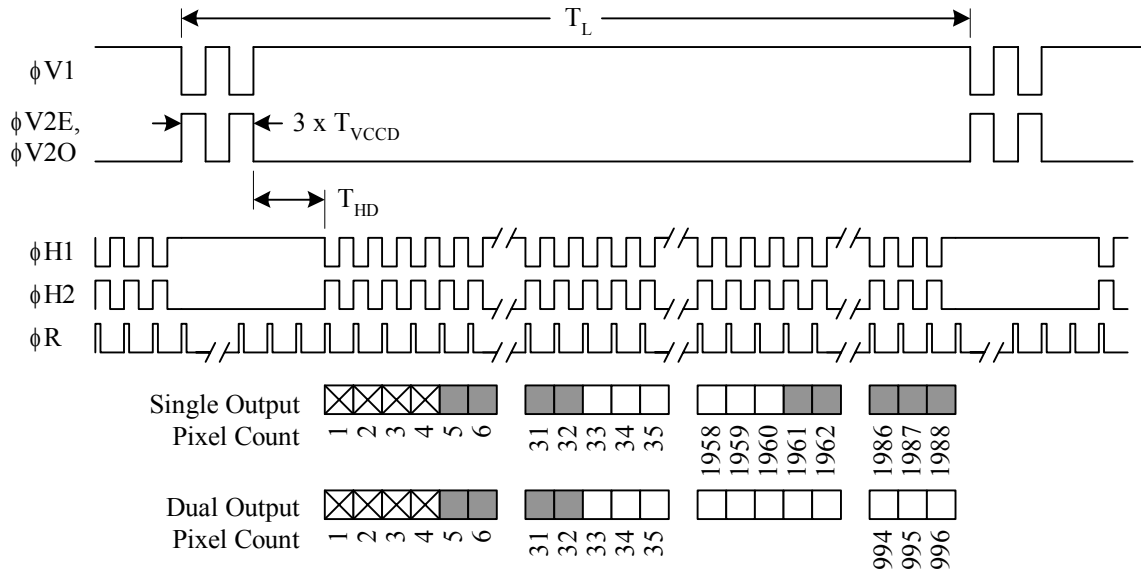
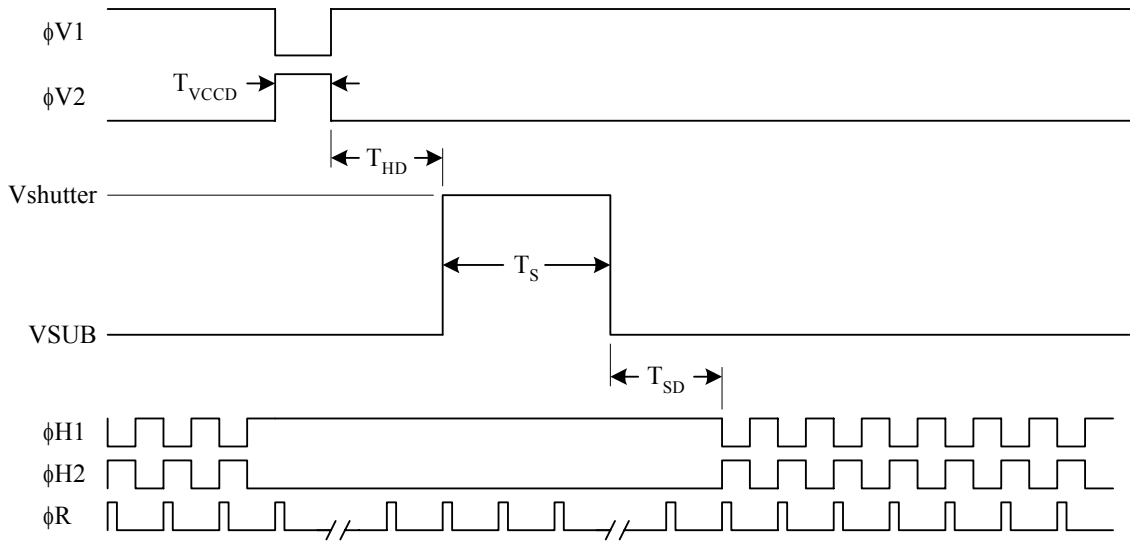

Figure 13: Line Timing

ELECTRONIC SHUTTER TIMING

Electronic Shutter Line Timing



Integration Time Definition

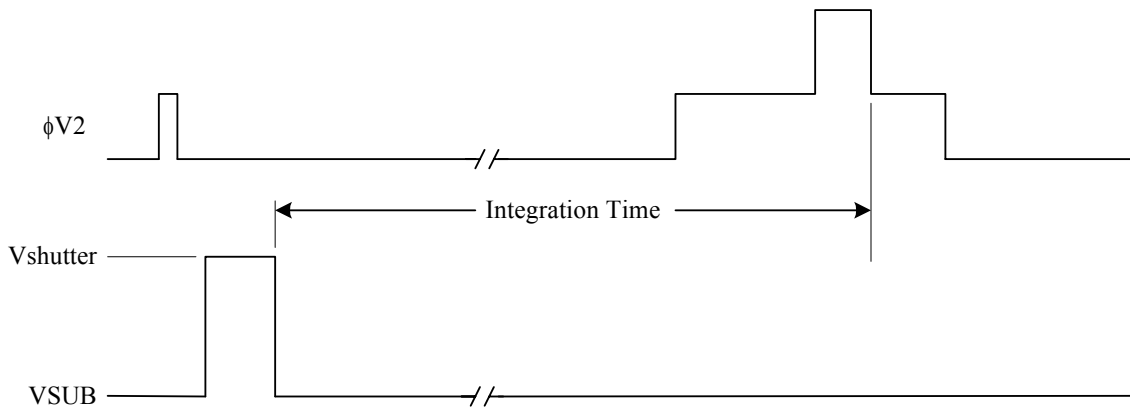

Figure 14: Electronic Shutter Timing Diagram

STORAGE AND HANDLING

STORAGE CONDITIONS

Description	Symbol	Minimum	Maximum	Units	Notes
Temperature	T	-55	70	°C	1
Humidity	RH	5	90	%	2

Notes:

1. Long-term exposure toward the maximum temperature will accelerate color filter degradation.
2. T=25°C. Excessive humidity will degrade MTF.

www.DataSheet4U.com

ESD

1. This device contains limited protection against Electrostatic Discharge (ESD). CCD image sensors can be damaged by electrostatic discharge. Failure to do so may alter device performance and reliability.
2. Devices should be handled in accordance with strict ESD procedures for Class 0 (<250V per JESD22 Human Body Model test), or Class A (<200V JESD22 Machine Model test) devices.

Devices are shipped in static-safe containers and should only be handled at static-safe workstations.
3. See Application Note MTD/PS-0224 "Electrostatic Discharge Control for Image Sensors" for proper handling and grounding procedures. This application note also contains recommendations for workplace modifications for the minimization of electrostatic discharge.
4. Store devices in containers made of electro-conductive materials.

COVER GLASS CARE AND CLEANLINESS

1. The cover glass is highly susceptible to particles and other contamination. Perform all assembly operations in a clean environment.
2. Touching the cover glass must be avoided
3. Improper cleaning of the cover glass may damage these devices. Refer to Application Note MTD/PS-0237 "Cover Glass Cleaning for Image Sensors"

ENVIRONMENTAL EXPOSURE

1. Do not expose to strong sun light for long periods of time. The color filters and/or microlenses may become discolored. Long time exposures to a static high contrast scene should be avoided. The image sensor may become discolored and localized changes in response may occur from color filter/microlens aging.
2. Exposure to temperatures exceeding the absolute maximum levels should be avoided for storage and operation. Failure to do so may alter device performance and reliability.
3. Avoid sudden temperature changes.
4. Exposure to excessive humidity will affect device characteristics and should be avoided. Failure to do so may alter device performance and reliability.
5. Avoid storage of the product in the presence of dust or corrosive agents or gases.

Long-term storage should be avoided. Deterioration of lead solderability may occur. It is advised that the solderability of the device leads be re-inspected after an extended period of storage, over one year.

SOLDERING RECOMMENDATIONS

1. The soldering iron tip temperature is not to exceed 370°C. Failure to do so may alter device performance and reliability.
2. Flow soldering method is not recommended. Solder dipping can cause damage to the glass and harm the imaging capability of the device. Recommended method is by partial heating. Kodak recommends the use of a grounded 30W soldering iron. Heat each pin for less than 2 seconds duration.

MECHANICAL DRAWINGS

COMPLETED ASSEMBLY

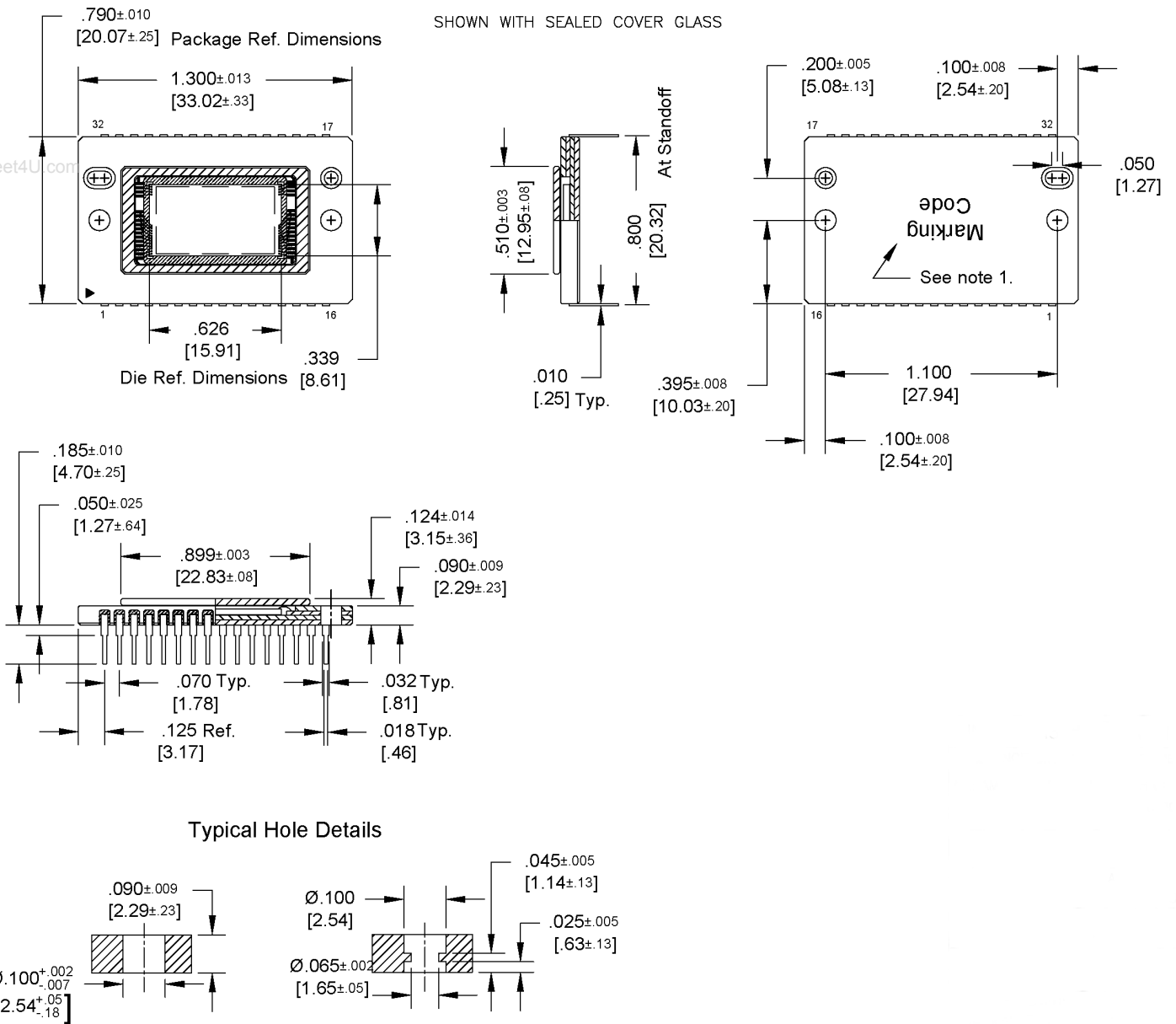

Figure 15: Completed Assembly (1 of 2)

Notes:

1. See Ordering Information for marking code
2. Cover glass is manually placed and visually aligned over die – location accuracy is not guaranteed

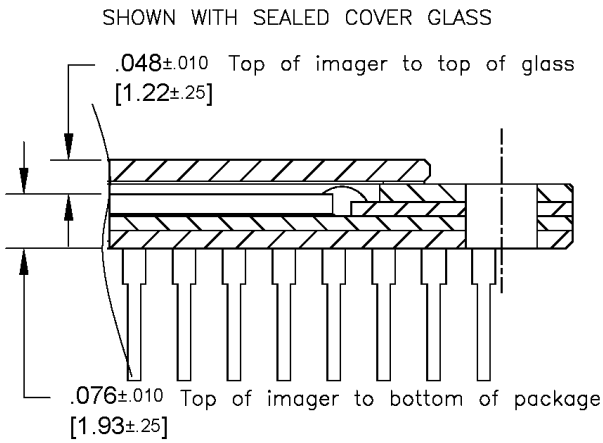
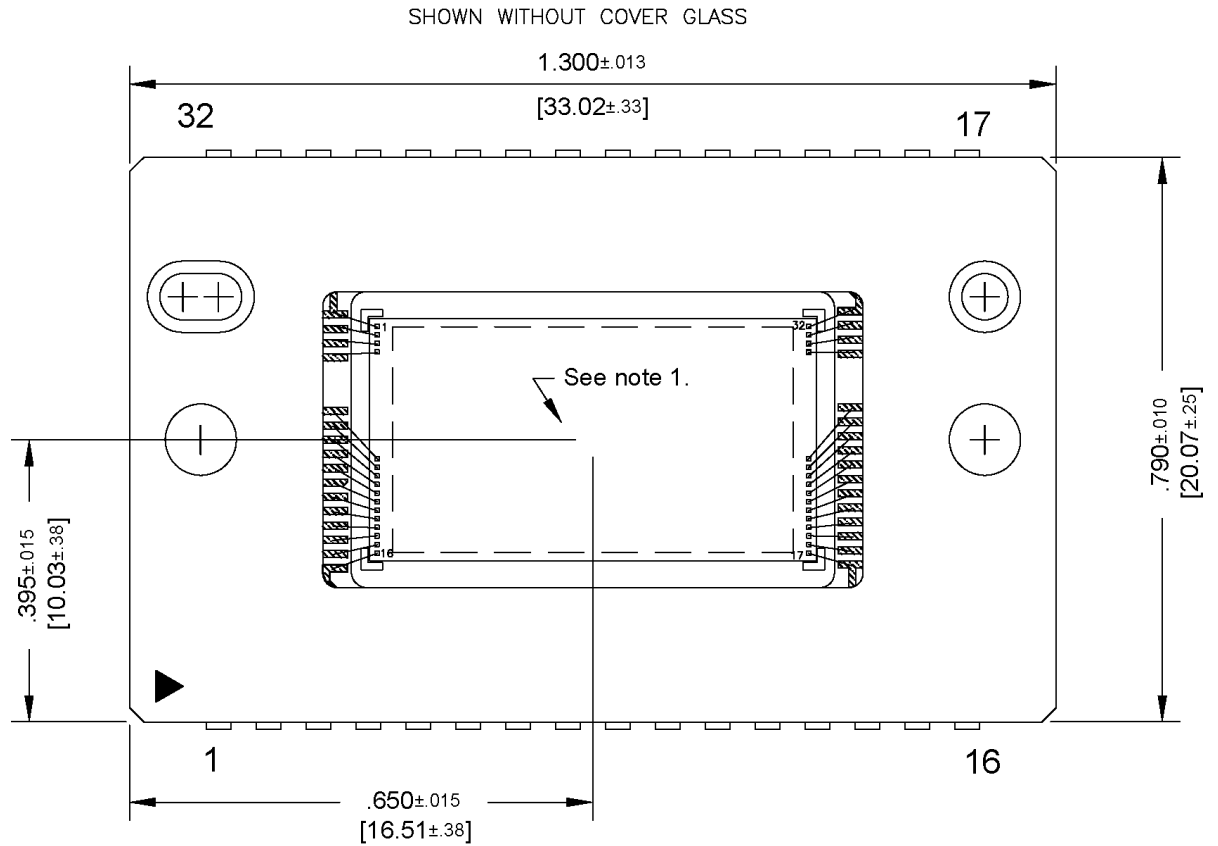

Figure 16: Completed Assembly (2 of 2)

Notes:

1. Center of image is nominally coincident with the center of the package
2. Die is aligned within ± 2 degree of any package cavity edge

COVER GLASS

Clear Cover Glass

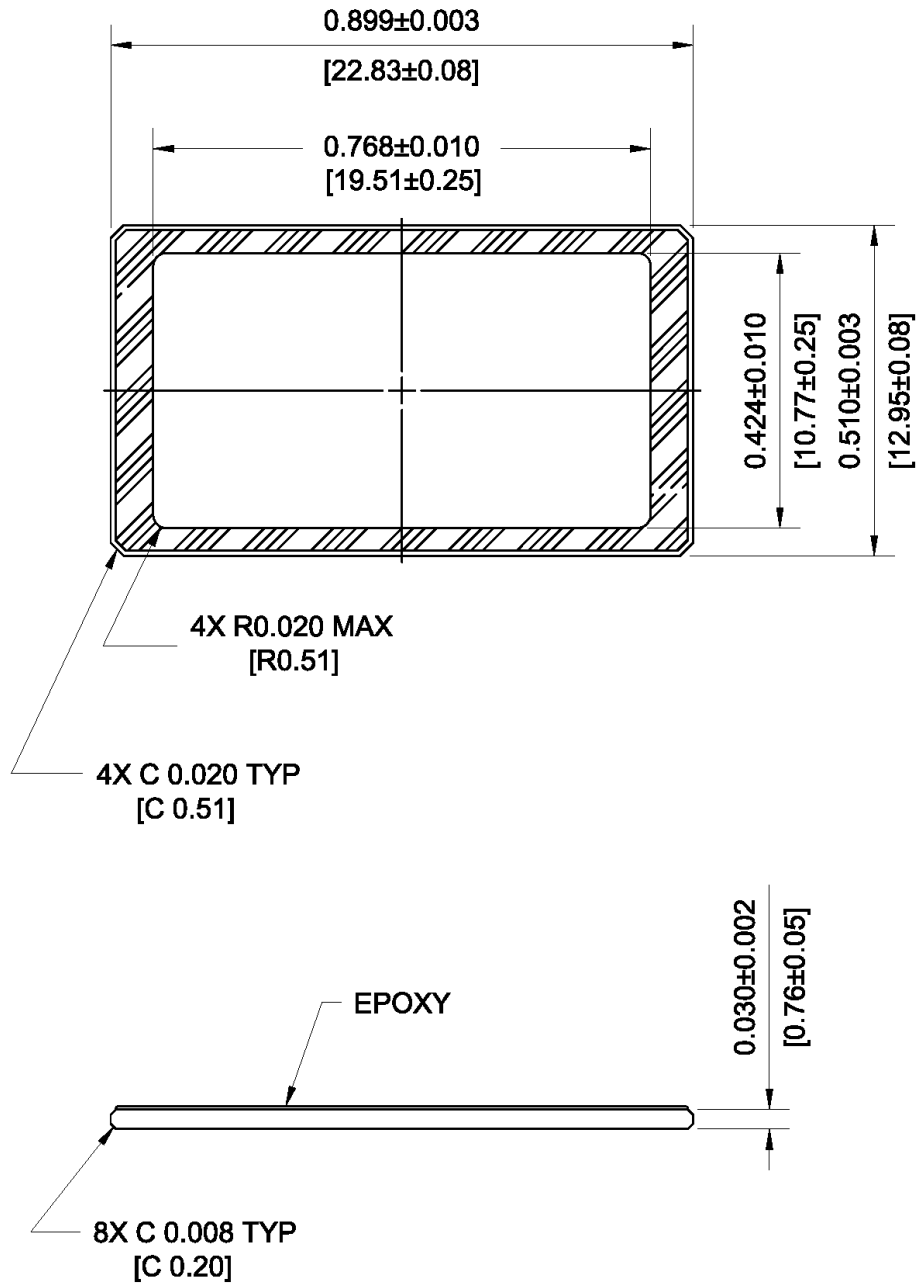

Figure 17: Clear Cover Glass Drawing

Notes:

1. Cover Glass Material: Schott D263 or equivalent
2. Dust/Scratch: 5 microns maximum

Quartz Cover Glass with AR Coatings

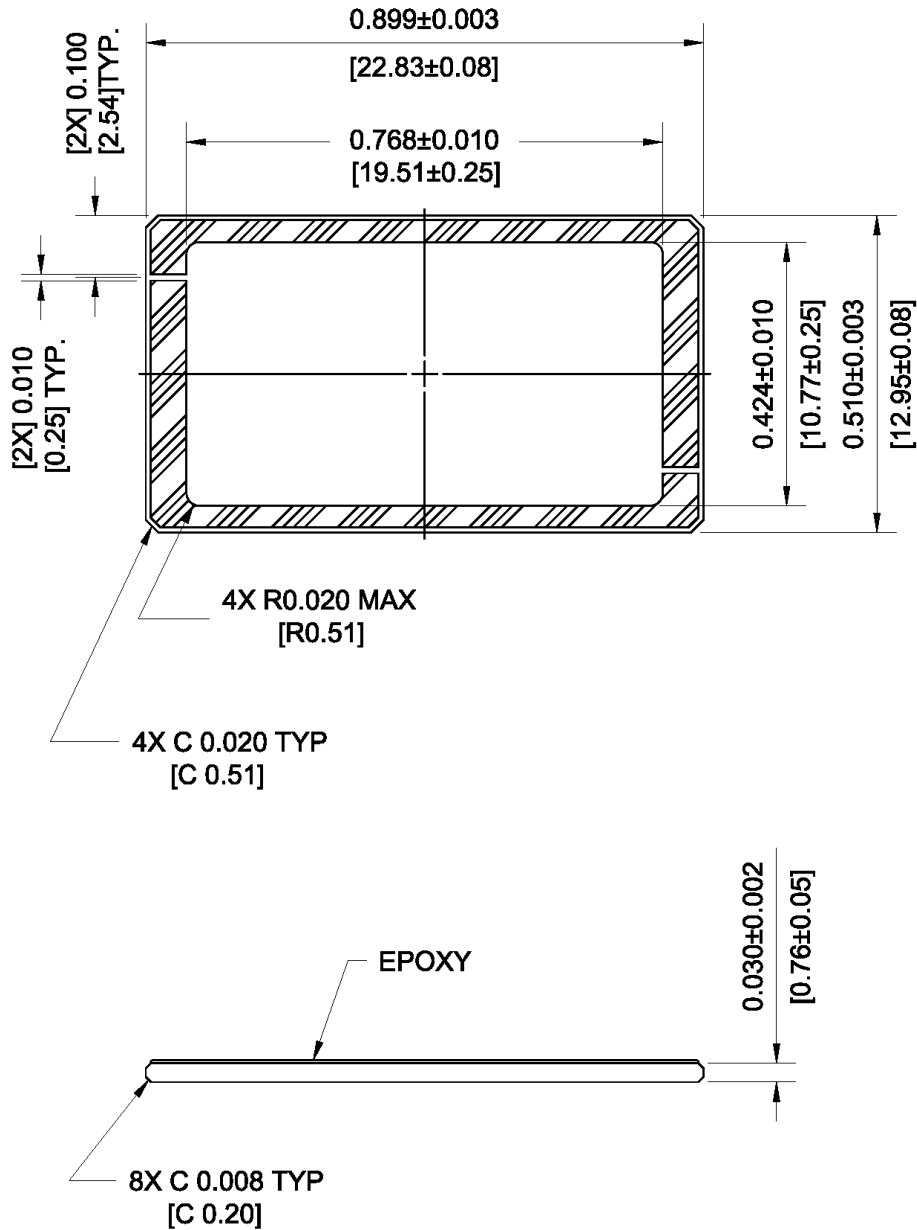

Figure 18: Quartz Cover Glass with AR Coating Drawing

Notes:

1. Cover Glass Material: SK1300 or equivalent
2. Dust/Scratch: 10 microns maximum
3. MAR Coat Each Side:
 - 340nm - 360nm: Reflectance <= 0.5%
 - 520nm - 550nm: Reflectance <= 4%

GLASS TRANSMISSION

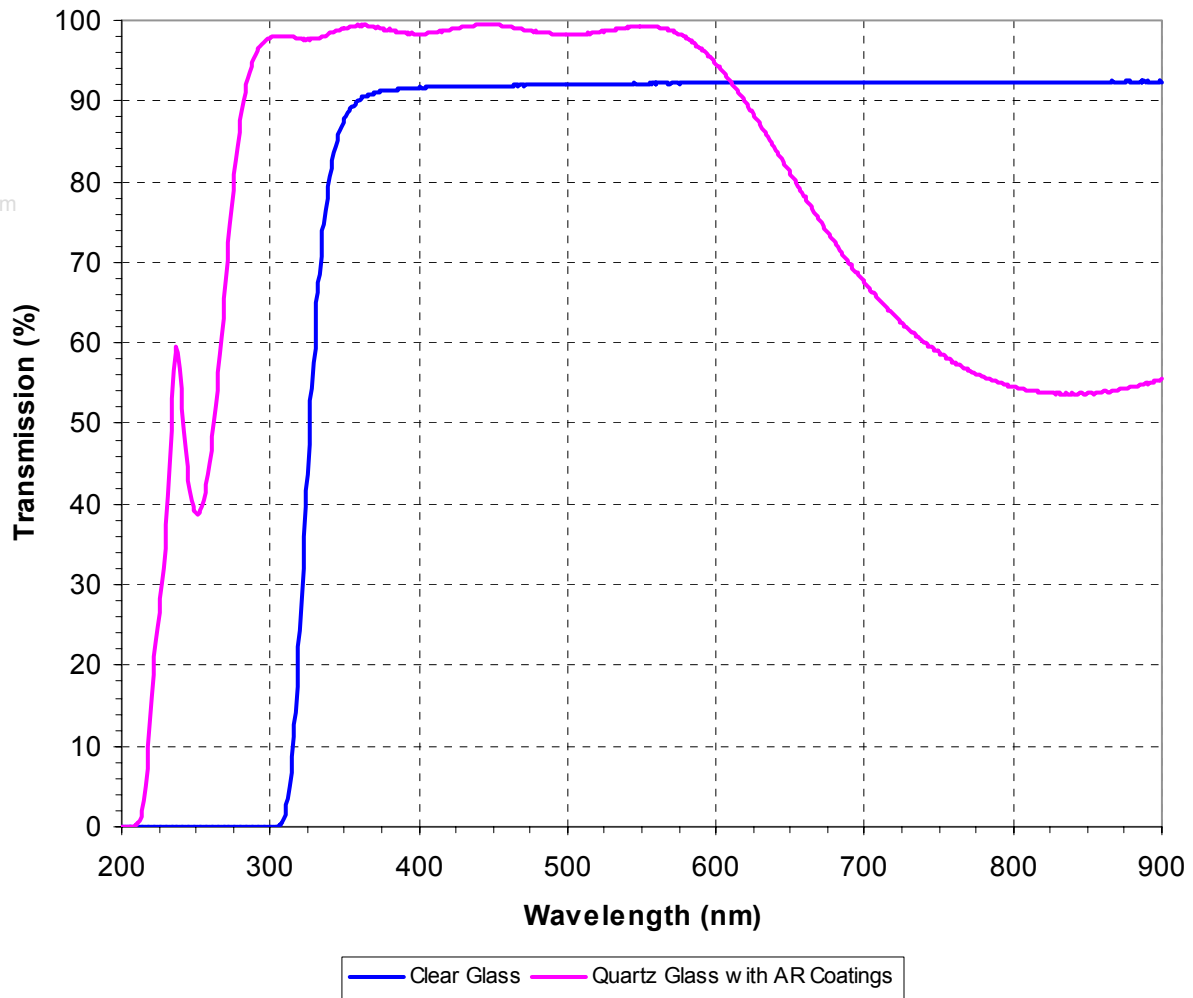

Figure 19: Cover Glass Transmission

QUALITY ASSURANCE AND RELIABILITY

QUALITY STRATEGY

All image sensors will conform to the specifications stated in this document. This will be accomplished through a combination of statistical process control and inspection at key points of the production process. Typical specification limits are not guaranteed but provided as a design target. For further information refer to ISS Application Note MTD/PS-0292, Quality and Reliability.

REPLACEMENT

All devices are warranted against failure in accordance with the terms of Terms of Sale. This does not include failure due to mechanical and electrical causes defined as the liability of the customer below.

LIABILITY OF THE SUPPLIER

A reject is defined as an image sensor that does not meet all of the specifications in this document upon receipt by the customer.

LIABILITY OF THE CUSTOMER

Damage from mechanical (scratches or breakage), electrostatic discharge (ESD) damage, or other electrical misuse of the device beyond the stated absolute maximum ratings, which occurred after receipt of the sensor by the customer, shall be the responsibility of the customer.

Kodak reserves the right to change any information contained herein without notice. All information furnished by Kodak is believed to be accurate.

WARNING: LIFE SUPPORT APPLICATIONS POLICY

Kodak image sensors are not authorized for and should not be used within Life Support Systems without the specific written consent of the Eastman Kodak Company. Product warranty is limited to replacement of defective components and does not cover injury or property or other consequential damages.

RELIABILITY

Information concerning the quality assurance and reliability testing procedures and results are available from the Image Sensor Solutions and can be supplied upon request. For further information refer to ISS Application Note MTD/PS-0292, Quality and Reliability.

TEST DATA RETENTION

Image sensors shall have an identifying number traceable to a test data file. Test data shall be kept for a period of 2 years after date of delivery.

MECHANICAL

The device assembly drawing is provided as a reference. The device will conform to the published package tolerances.

REVISION CHANGES

Revision Number	Description of Changes
0.0	<ul style="list-style-type: none"> Initial Formal Version.
1.0	<ul style="list-style-type: none"> Page 8 section 3.5 AC Timing Conditions table: Added Tve: Vertical Clock Edge Alignment Page 10: Added Figure 5 Vertical Clock Timing – Edge Position Page 15: Updated Figure 9 Frame Rate to show dual mode out to 40MHz. Previous plot cut off dual mode at 35 MHz Page 22: Added that a cluster defect will be no wider that two defective pixels. Page 22: Added a note that there will be at least two good pixels between any two major defects (pixels or clusters) Removed appendix 1 Added revision changes
2.0	<ul style="list-style-type: none"> Section 4.2, new color quantum efficiency
3.0	<ul style="list-style-type: none"> Updated format Updated defect definitions section Added Storage and Handling section Updated completed assembly drawing Added cover glass drawings Added cover glass transmission curves

This page intentionally left blank.

www.DataSheet4U.com

This page intentionally left blank.

www.DataSheet4U.com

This page intentionally left blank.

www.DataSheet4U.com

