



DC COMPONENTS CO., LTD.

RECTIFIER SPECIALISTS

KBPC6005

THRU

KBPC610

TECHNICAL SPECIFICATIONS OF SINGLE-PHASE SILICON BRIDGE RECTIFIER

VOLTAGE RANGE - 50 to 1000 Volts

CURRENT - 6.0 Amperes

FEATURES

- * Surge overload rating: 175 Amperes peak
- * Low forward voltage drop
- * Small size: simple installation

MECHANICAL DATA

- * Case: Molded plastic
- * Epoxy: UL 94V-0 rate flame retardant
- * Lead: MIL-STD-202E, Method 208 guaranteed
- * Polarity: Symbols molded or marked on body
- * Mounting position: Any
- * Weight: 6.1 grams

MAXIMUM RATINGS AND ELECTRICAL CHARACTERISTICS

Ratings at 25 °C ambient temperature unless otherwise specified.
 Single phase, half wave, 60 Hz, resistive or inductive load.
 For capacitive load, derate current by 20%.

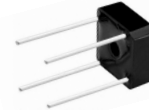

BR-6

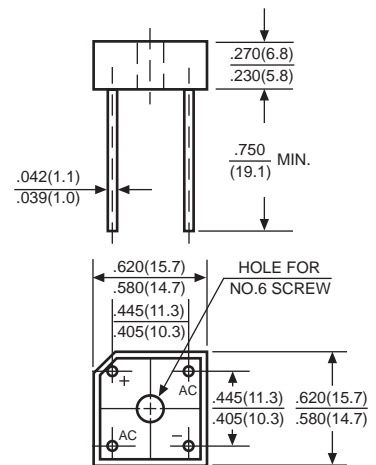

Dimensions in inches and (millimeters)

	SYMBOL	KBPC 6005	KBPC 601	KBPC 602	KBPC 604	KBPC 606	KBPC 608	KBPC 610	UNITS
Maximum Recurrent Peak Reverse Voltage	V _{RRM}	50	100	200	400	600	800	1000	Volts
Maximum RMS Bridge Input Voltage	V _{RMS}	35	70	140	280	420	560	700	Volts
Maximum DC Blocking Voltage	V _{DC}	50	100	200	400	600	800	1000	Volts
Maximum Average Forward Rectified Output Current at T _c = 100 °C	I _O	6.0							Amps
Peak Forward Surge Current 8.3 ms single half sine-wave superimposed on rated load (JEDEC method)	I _{FSM}	175							Amps
Maximum Forward Voltage Drop per element at 3.0A DC	V _F	1.0							Volts
Maximum DC Reverse Current at Rated DC Blocking Voltage per element	@ T _A = 25 °C	10							uAmps
	@ T _C = 100 °C	500							
I ² t Rating for Fusing (t<8.3ms)	I ² t	127							A ² Sec
Typical Junction Capacitance (Note1)	C _J	186							pF
Typical Thermal Resistance (Note 2)	R _{θJA}	22							°C/W
Operating Temperature Range	T _J	-55 to + 125							°C
Storage Temperature Range	T _{STG}	-55 to + 150							°C

NOTES : 1. Measured at 1 MHz and applied reverse voltage of 4.0 volts

2. Thermal Resistance from Junction to Ambient and from junction to lead mounted on P.C.B. with 0.5 x 0.5" (13x13mm) copper pads.

RATING AND CHARACTERISTIC CURVES (KBPC6005 THRU KBPC610)

FIG. 1 - MAXIMUM NON-REPETITIVE FORWARD SURGE CURRENT

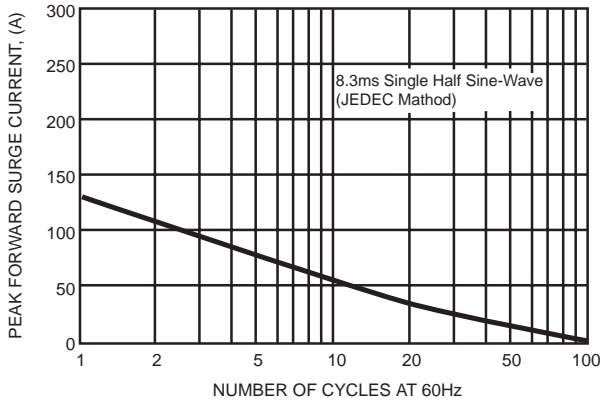

FIG. 2 - TYPICAL FORWARD CURRENT DERATING CURVE

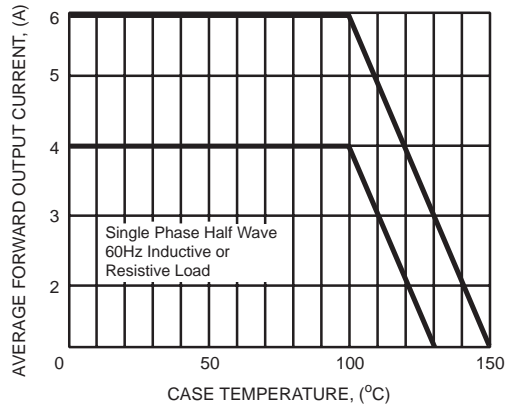

FIG. 3 - TYPICAL INSTANTANEOUS FORWARD CHARACTERISTICS

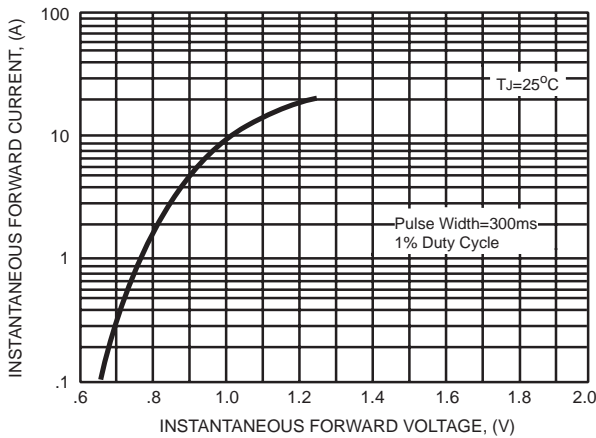
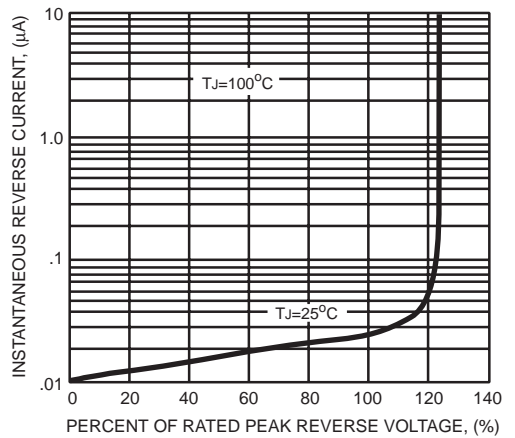

FIG. 4 - TYPICAL REVERSE CHARACTERISTICS



DC COMPONENTS CO., LTD.