

SPEC. NO.

TQ3C-8EACO-E1CUQ24-00

DATE

May 20, 2005

FOR :

TYPE : KCG047QVLAE-G00

CONTENTS

1. Application
2. Construction and Outline
3. Mechanical Specifications
4. Absolute Maximum Ratings
5. Electrical Characteristics
6. Optical Characteristics
7. Circuit Block Diagram
8. Interface Signals
9. Interface Timing Chart
10. Data and Screen
11. Input Timing Characteristics
12. Supply Voltage Sequence Condition
13. LED Backlight Characteristics
14. Design Guidance for Analog Touch-Panel(T/P)
15. Lot Number Identification
16. Warranty
17. Precautions for Use
18. Reliability Data / Environmental Test
19. Outline Drawing

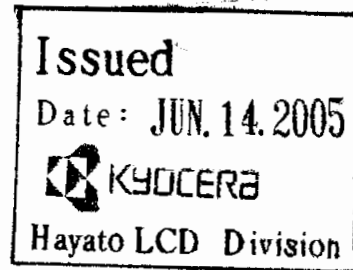

KYOCERA CORPORATION
KAGOSHIMA HAYATO PLANT
LCD DIVISION

This specification is subject to change without notice.
Consult Kyocera before ordering.

Original	Designed by :Engineering Dept.			Confirmed by :QA Dept.	
Issue Data	Prepared	Checked	Approved	Checked	Approved
May 20, 2005	<i>T. Onotera</i>	<i>Y. Yamazaki</i>	<i>M. Fujitani</i>	<i>Y. Yoshida</i>	<i>S. Higashida</i>

Caution

1. This Kyocera LCD module has been specifically designed for use only in electronic devices in the areas of audio control, office automation, industrial control, home appliances, etc. The modules should not be used in applications where module failure could result in physical harm or loss of life, and Kyocera expressly disclaims any and all liability relating in any way to the use of the module in such applications.
2. Customer agrees to indemnify, defend and hold Kyocera harmless from and against any and all actions, claims, losses, damages, liabilities, awards, costs, and expenses, including legal fees, resulting from or arising out of Customer's use, or sale for use, of Kyocera modules in applications.
3. Kyocera shall have the right, which Customer hereby acknowledges, to immediately scrap or destroy tooling for Kyocera modules for which no Purchase Orders have been received from the Customer in a two-year period.

Revision Record

Date	Designed by: Engineering Dept.			Confirmed by: QA Dept.	
	Prepared	Checked	Approved	Checked	Approved
Rev. No.	Date	Page	Descriptions		

1. Application

This data sheet defines the specification for a $(320 \times R.G.B) \times 240$ dot, STN Transmissive color dot matrix type Liquid Crystal Display with LED backlight. 『RoHS Compliance』

2. Construction and Outline

$(320 \times R.G.B) \times 240$ dots, COG type LCD with LED backlight.

Backlight system : Side-edge type (LED).

Polarizer : Glare treatment.

Additional circuit : Bias voltage circuit, Randomizing circuit, DC-DC converter, Constant current circuit for LED Backlight

Touch Panel : Analog type . Non-Glare treatment.

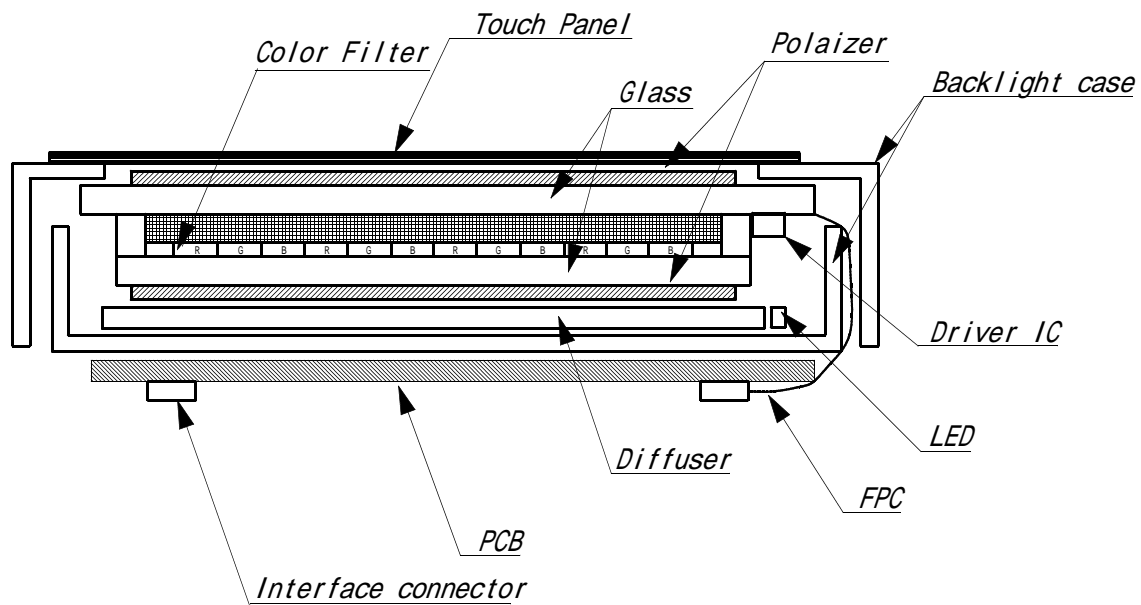

This drawing is showing conception only.

3. Mechanical Specifications

ITEM	SPECIFICATION	UNIT
Outline dimensions	122.4(W) × 90.0(H) × 5.7(D)(PCB and bosses are not included) Refer outline drawing in detail.	mm
Effective viewing area	98.0 (W) × 74.0 (H)	mm
Dot number	(320×R.G.B) (W) × 240 (H)	Dots
Dot size	0.08 (W) × 0.28 (H)	mm
Dot pitch	0.10 (W) × 0.30 (H)	mm
Display color *1	White *2	-
Base color *1	Black *2	-
Mass	(120)	g

*1 Due to the characteristics of the LC material, the color vary with environmental temperature.

*2 Negative-type display

Display data "H" :R.G.B Dots ON : White

Display data "L" :R.G.B Dots OFF : Black

3-2. Mechanical Specifications of touch panel

ITEM	SPECIFICATION	UNIT
Input	Radius-0.8 stylus or Finger	-
Actuation Force	0.5N ± 0.3N	-
Transmittance	Typ.80	%
Surface hardness	pencil hardness 2H or more according	-

4. Absolute Maximum Ratings

4-1. Electrical absolute maximum ratings

ITEM	SYMBOL	MIN.	MAX.	UNIT
Supply voltage for logic	VDD	0	6.0	V
Supply voltage for LCD driving	VCONT	0	VDD	V
Input signal voltage for LCD *1	Vin	0	VDD	V
FRM frequency	f_{FRM}	-	150	Hz
LED forward current (Backlight)	IF	-	12	mA
Supply voltage for backlight	VinB	0	6.0	V
Backlight ON-OFF	BLEN	0	VinB	V
Brightness adjust voltage	VBRT	0	VinB	V
Touch Panel Supply voltage	Vtp	0	6.0	V
Touch Panel Input Current	Itp	0	0.5	mA

*1 Input signal :CP, LOAD, FRM, DISP, D0~D7

4-2. Environmental absolute maximum ratings

ITEM	SYMBOL	MIN	MAX	UNIT
Operating temperature *1	Top	0	50	
Storage temperature *2	T _{STO}	-20	60	
Operating humidity *3	Hop	10	*4	%RH
Storage humidity *3	H _{STO}	10	*4	%RH
Vibration	-	*5	*5	-
Shock	-	*6	*6	-

*1 LCD's display quality shall not be guaranteed at the temperature range of :
below 0 and upper 40 .

*2 Temp. = (-20) < (48h) , Temp = (60) < (168h)
Store LCD panel at normal temperature/humidity. Keep it free from vibration and shock.
LCD panel that is kept at low or high temperature for a long time can be defective due to
the other conditions, even if the temperature satisfies standard.
(Please refers to 16. Precautions for use)

*3 Non-condensation.

*4 Temp. 40 , 85% RH Max.

Temp. > 40 , Absolute Humidity shall be less than 85%RH at 40 .

*5

Frequency	10 ~ 55 Hz	Converted to acceleration value : (0.3 ~ 9 m/s ²)
Vibration width	0.15 mm	
Interval	10-55-10 Hz 1 minute	

2 hours in each direction X/Y/Z (6 hours as total)
EIAJ ED-2531

*6 Acceleration: 490m/s²
Pulse width : 11 ms
3 times in each direction : ±X/ ±Y/ ±Z.
EIAJ ED-2531

5. Electrical Characteristics

5-1. VDD=5.00V

VDD = 5.00V ± 0.25V , Temp. = 0 ~ 50

ITEM	SYMBOL	CONDITION	MIN.	TYP.	MAX.	UNIT
Supply voltage for logic	VDD	-	4.75	5.00	5.25	V
LCD driving voltage *1	Vop= VCONT	0	1.20	-	-	V
		25	1.30	1.80	2.30	V
		50	-	-	2.40	V
Input voltage (FRM,LOAD,CP,DO ~ D7,DISP)	Vin	"H" level	0.8VDD	-	VDD	V
		"L" level	0	-	0.2VDD	V
Input current	Iin	Vin=VDD or VSS	-100	-	100	μA
Rush current for logic	Irush	When rush current happens	3.0A(Peak) × 1ms			
Clock frequency	f _{CP}	-	2.02	2.16	10.00	MHz
Frame frequency *2	f _{FRM}	-	70	75	150	Hz
Current consumption for logic	IDD	*3	-	30	45	mA
Power consumption	Pdisp		-	150	225	mW

*1 Maximum contrast is obtained by adjusting the LCD driving voltage (Vop=Vcont) while at the viewing angle of = 0°

*2 In consideration of display quality, it is recommended that frame frequency is set in the range of 70-80Hz. When you have to use higher frame and clock frequencies, confirm the LCD's performance and quality prior to finalizing the frequency values:
Generally, as frame and clock frequencies become higher current consumption will get bigger and display quality will be degraded.

*3 VCONT = Vop, f_{FRM} = 75Hz, f_{CP} = 2.16MHz, Temp. = 25

Display IDD max pattern :

```

1 2 3 4 5 6.....960(dot)
1
2
|
|
|
239
240
(dot)

```

5-2. VDD=3.30V

VDD = 3.30V ± 0.30V , Temp. = 0 ~ 50

ITEM	SYMBOL	CONDITION	MIN.	TYP.	MAX.	UNIT
Supply voltage for logic	VDD	-	3.00	3.30	3.60	V
LCD driving voltage *1	Vop= VCONT	0	1.20	-	-	V
		25	1.30	1.80	2.30	V
		50	-	-	2.40	V
Input voltage (FRM,LOAD,CP,D0 ~ D7,DISP)	Vin	"H" level	0.8VDD	-	VDD	V
		"L" level	0	-	0.2VDD	V
Input current	Iin	Vin=VDD or VSS	-100	-	100	μA
Rush current for logic	Irush	When rush current happens	3.0A(Peak) × 1ms			
Clock frequency	f _{CP}	-	2.02	2.16	10.00	MHz
Frame frequency *2	f _{FRM}	-	70	75	150	Hz
Current consumption for logic	IDD	*3	-	45	68	mA
Power consumption	Pdisp		-	150	225	mW

- *1 Maximum contrast is obtained by adjusting the LCD driving voltage (Vop=Vcont) while at the viewing angle of = 0°
- *2 In consideration of display quality, it is recommended that frame frequency is set in the range of 70-80Hz. When you have to use higher frame and clock frequencies, confirm the LCD's performance and quality prior to finalizing the frequency values:
Generally, as frame and clock frequencies become higher current consumption will get bigger and display quality will be degraded.

*3 VCONT = Vop, f_{FRM} = 75Hz, f_{CP} = 2.16MHz, Temp. = 25

Display IDD max pattern :

```

1 2 3 4 5 6 .....960(dot)
1
2
|
|
|
239
240
(dot)

```

5-2. Touch Panel

5-2-1. Terminal resistance

Between xL and xR : 200 ~ 1000

Between yU and yL : 200 ~ 1000

5-2-2. Linearity

± 1.5%

5-2-3. Insulation resistance

100M or more at DC25V

6 . Optical Characteristics

Measuring Spot 6.0mm Temp. = 25

ITEM		SYMBOL	CONDITION	MIN.	TYP.	MAX.	UNIT	
Response time	Rise	Tr	= =0 °	-	190	290	ms	
	Down	Td	= =0 °	-	180	280	ms	
Viewing angle range			CR 2	Upper	-	20	-	deg.
				Lower	-	30	-	
				Left	-	50	-	deg.
				Right	-	50	-	
Contrast ratio		CR	= =0 °	15	30	-	-	
Brightness		L	(IF=10mA/1 LED line)	(50)	(90)	-	cd/m ²	
Chromaticity coordinates	Red	x	= =0 °	(0.44)	(0.49)	(0.54)	-	
		y		(0.30)	(0.35)	(0.40)		
	Green	x	= =0 °	(0.24)	(0.29)	(0.34)		
		y		(0.43)	(0.48)	(0.53)		
	Blue	x	= =0 °	(0.10)	(0.15)	(0.20)		
		y		(0.07)	(0.12)	(0.17)		
	White	x	= =0 °	(0.22)	(0.27)	(0.32)		
		y		(0.24)	(0.29)	(0.34)		

Optimum contrast is obtained by adjusting the LCD driving voltage (Vop=Vcont) while at the viewing angle of = =0 °

6-1. Contrast ratio is defined as follows:

$$CR = \frac{\text{Brightness at all pixels "White"}}{\text{Brightness at all pixels "Black"}}$$

6-2. Definition of Vop

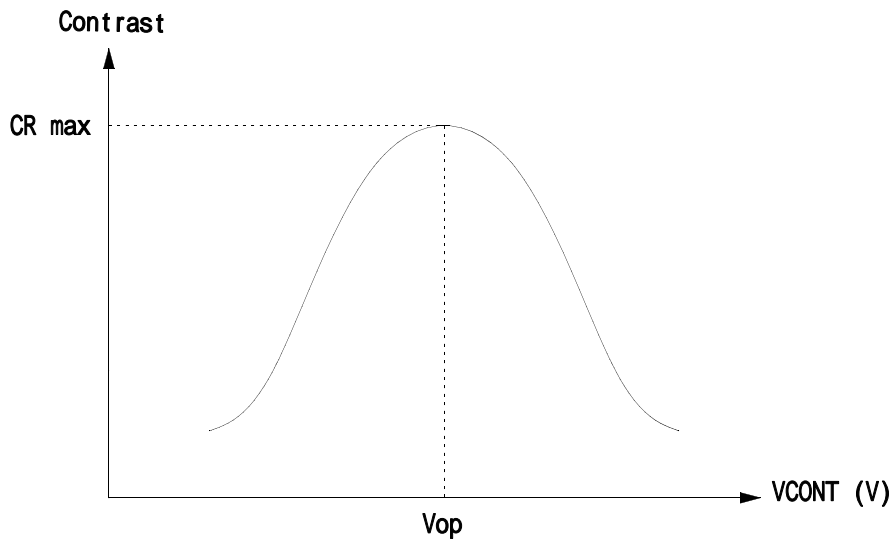

6-3. Definition of response time

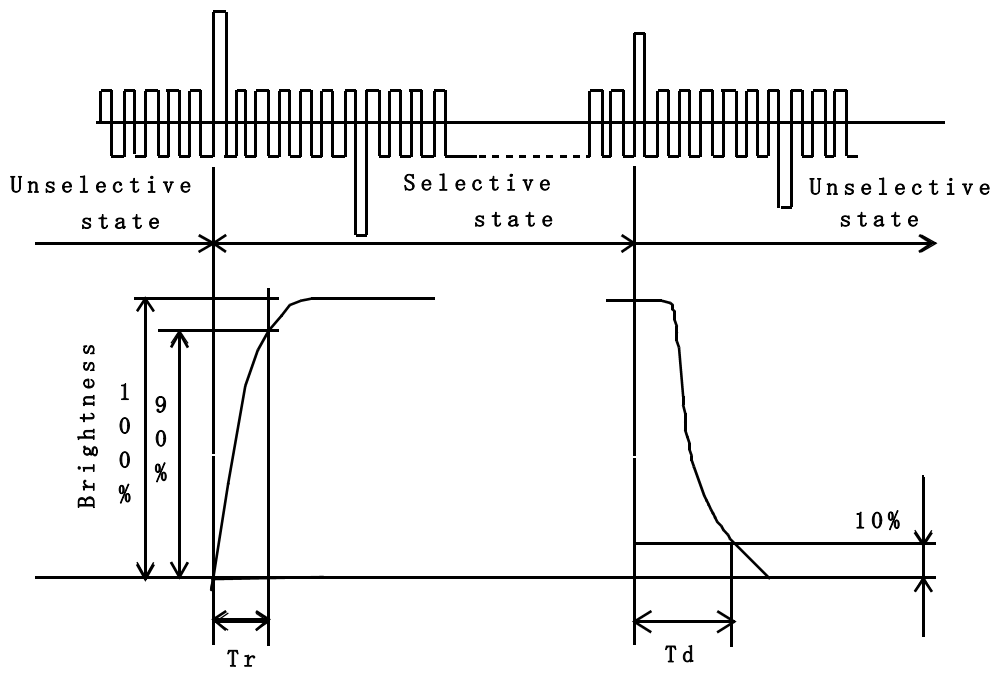

6-4. Definition of viewing angle

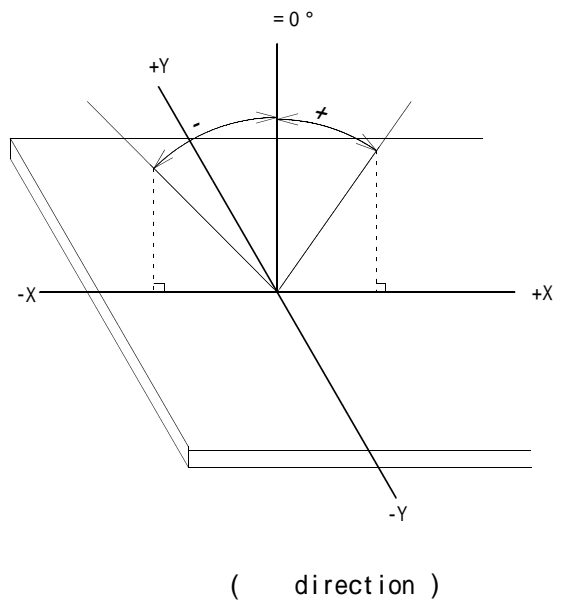
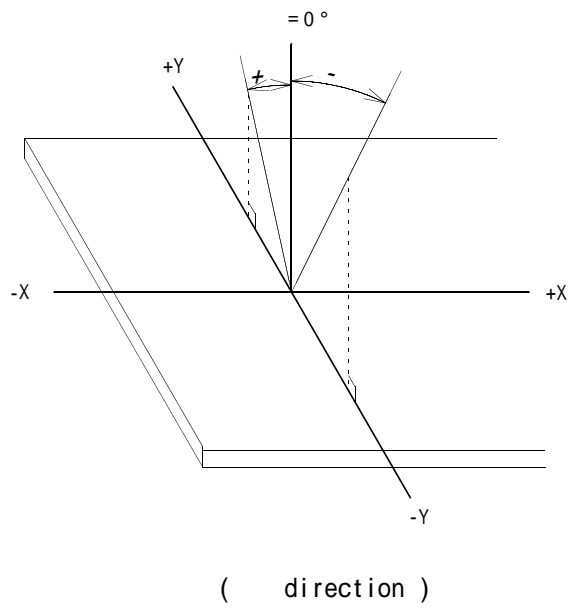

6-5. Measuring points

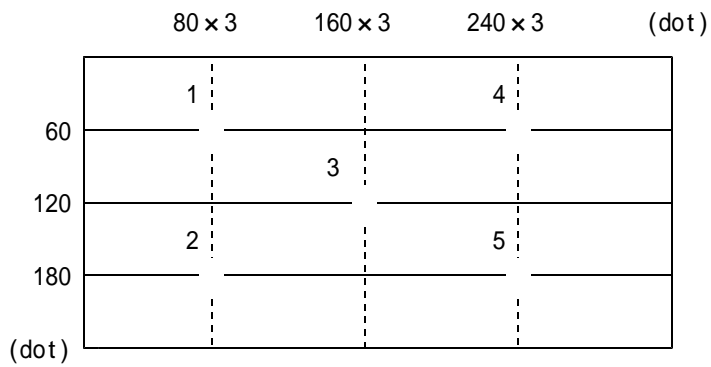

- 1) Rating is defined as the average brightness inside the viewing area.
- 2) 30 minutes after LED is turned on. (Ambient Temp.=25)

7. Circuit Block Diagram

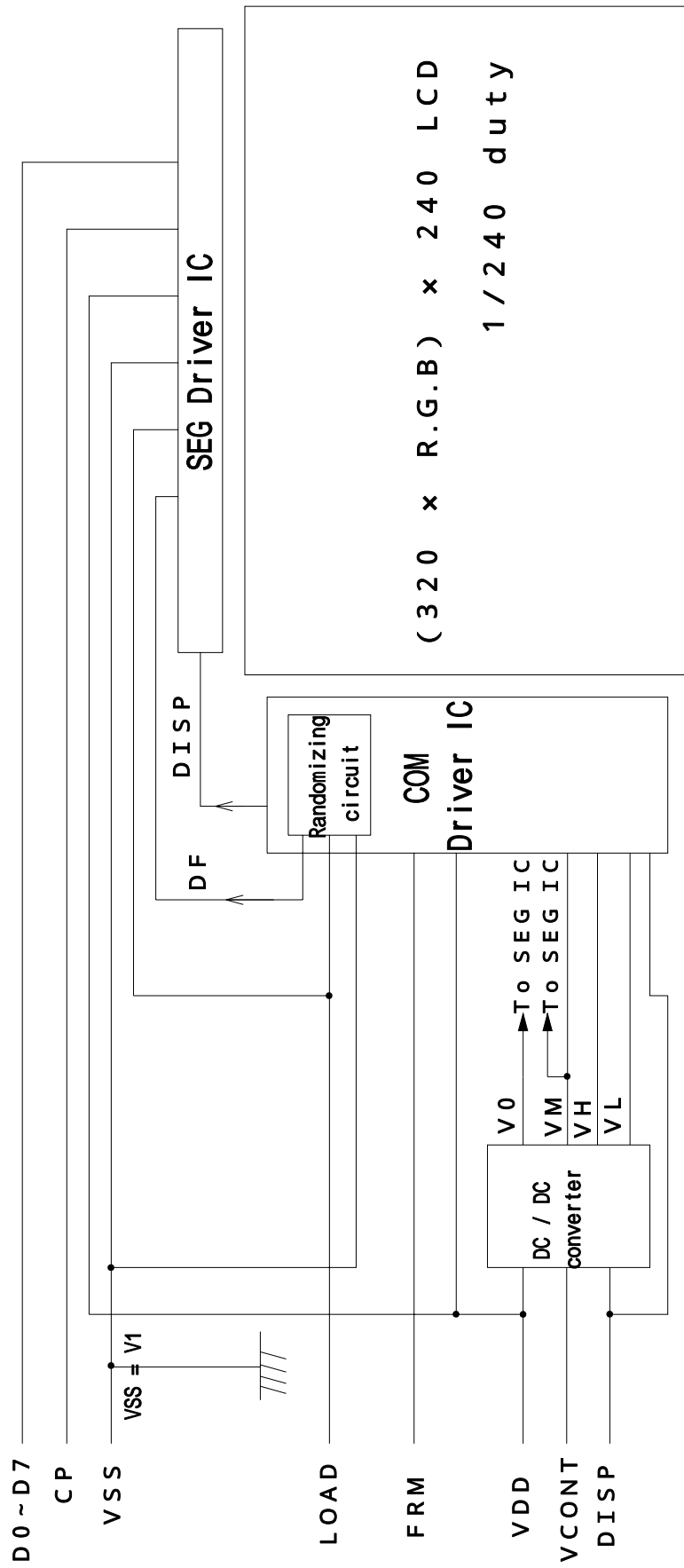

7-1. Power supply

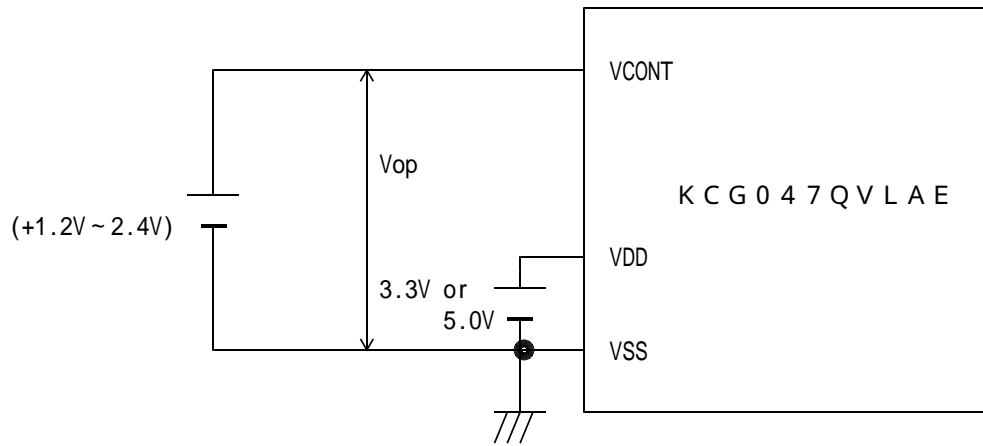

8. Interface signals

8-1. LCD

PIN NO.	SYMBOL	DESCRIPTION	LEVEL
1	FRM	Synchronous signal for driving scanning line	H
2	LOAD	Data signal latch clock	H L
3	CP	Data signal shift clock	H L
4	DISP	Display control signal	H(ON),L(OFF)
5	VDD	Power supply for logic	
6	VSS	GND	
7	VCONT	LCD adjust voltage	
8	D7	Display data	H(ON),L(OFF)
9	D6		
10	D5		
11	D4		
12	D3		
13	D2		
14	D1		
15	D0		
16	VDD	Supply voltage for logic	-
17	VDD		
18	VSS	GND	-
19	VSS		
20	VSS		
20	VSS		

LCD side connector : 08-6210-020-340-800+ (ELCO)
 Recommended matching connector : 0.5mm pitch FFC or FPC

8-2. Backlight

PIN No.	SYMBOL	DESCRIPTION
1	VinB	Supply voltage
2	VinB	
3	VinB	
4	VinB	
5	BLEN	Backlight ON-OFF (H : ON , L : OFF)
6	VBRT	Brightness adjust voltage
7	GND	GND
8	GND	
9	GND	
10	GND	

Backlight side connector : 08-6210-010-340-800+ (ELCO)
 Recommended matching connector : 0.5mm pitch FFC or FPC

8-3. Touch panel

PIN No.	SYMBOL	DESCRIPTION
1	yU	y-Upper terminal
2	xL	x-Left terminal
3	yL	y-Lower terminal
4	xR	x-Right terminal

9 . Interface Timing Chart

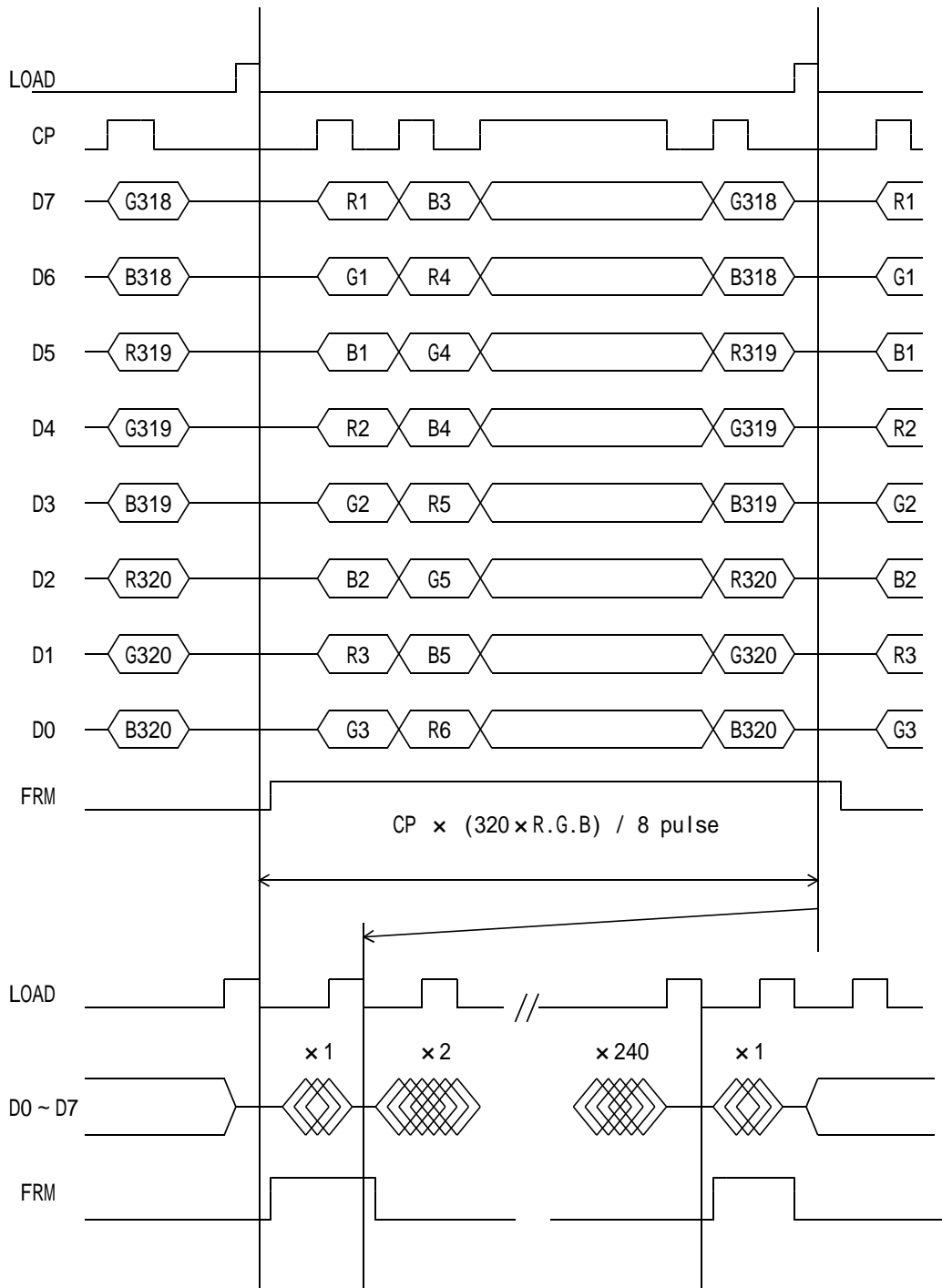

* The cycle of load signal should be stable and continuously applied without interruption.

* The above-mentioned timing chart shows a reference to set up a LCD module, not an electrical rating.

10 . Data and Screen

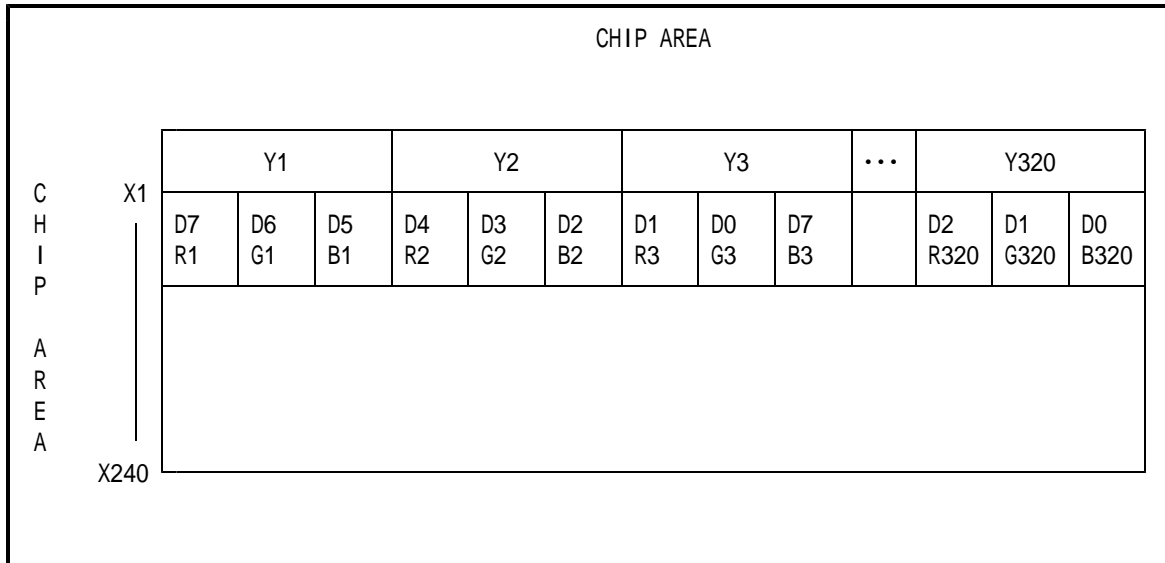

11. Input Timing Characteristics

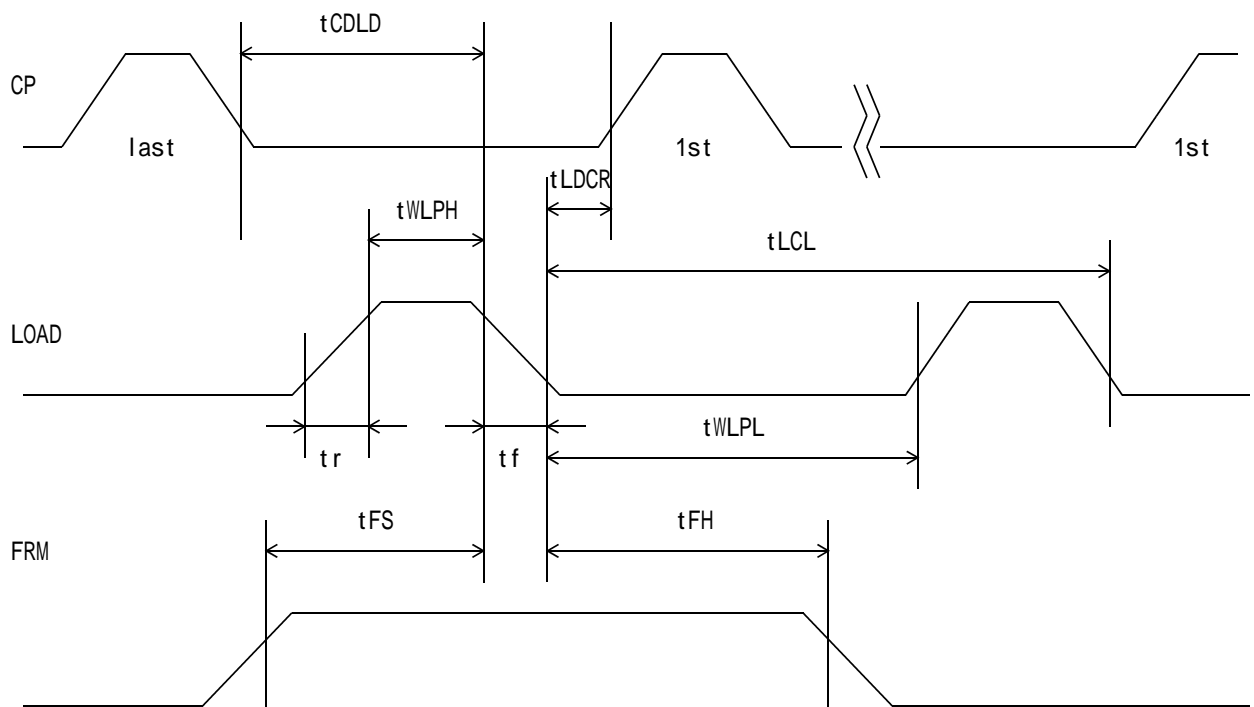
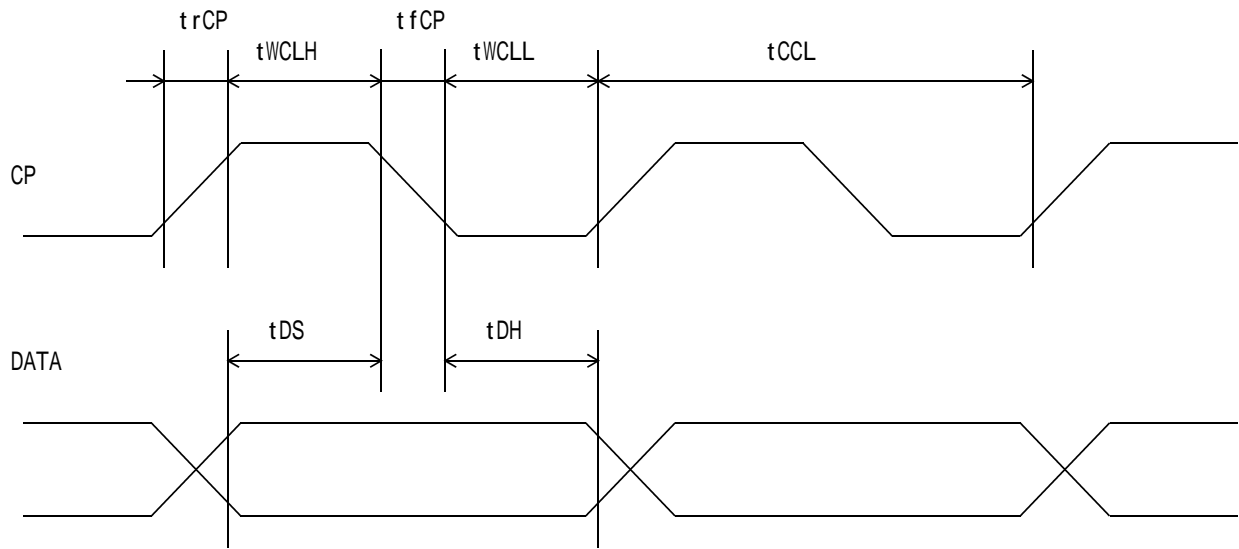

11-1. Switching characteristics (VDD = 5.00V)

Input Characteristics ; VDD = 5.00V ± 0.25V, Temp. = 0 ~ 50

ITEM	SYMBOL	MIN.	MAX.	UNIT
CP Cycle *1	tCCL	100	-	ns
CP "H" Pulse Width	tWCLH	30	-	ns
CP "L" Pulse Width	tWCLL	30	-	ns
CP Rise Up Time	trCP	-	15	ns
CP Fall Down Time	tfCP	-	15	ns
Data Set Up Time	tDS	25	-	ns
Data Hold Time	tDH	25	-	ns
LOAD "H" Pulse Width	tWLPH	40	-	ns
LOAD "L" Pulse Width	tWLPL	400	-	ns
LOAD Cycle *2	tLCL	500	-	ns
CP Down LOAD Down Delay Time	tCDLD	60	-	ns
LOAD Down CP Rise Delay Time	tLDCR	60	-	ns
Input Signal Rise Up Time	tr	-	20	ns
Input Signal Fall Down Time	tf	-	20	ns
FRM Data Set Up Time	tFS	120	-	ns
FRM Data Hold Time	tfH	30	-	ns

*1 CP Cycle is adjust so that FRM signal is 75Hz.

*2 Load cycle is const.

11-2. Switching characteristics (VDD = 3.30V)

Input Characteristics ; VDD = 3.30V ± 0.30V, Temp. = 0~50

ITEM	SYMBOL	MIN.	MAX.	UNIT
CP Cycle *1	tCCL	100	-	ns
CP "H" Pulse Width	tWCLH	40	-	ns
CP "L" Pulse Width	tWCLL	40	-	ns
CP Rise Up Time	trCP	-	20	ns
CP Fall Down Time	tfCP	-	20	ns
Data Set Up Time	tDS	35	-	ns
Data Hold Time	tDH	35	-	ns
LOAD "H" Pulse Width	tWLPH	50	-	ns
LOAD "L" Pulse Width	tWLPL	400	-	ns
LOAD Cycle *2	tLCL	500	-	ns
CP Down LOAD Down Delay Time	tCDLD	60	-	ns
LOAD Down CP Rise Delay Time	tLDCR	80	-	ns
Input Signal Rise Up Time	tr	-	20	ns
Input Signal Fall Down Time	tf	-	20	ns
FRM Data Set Up Time	tFS	120	-	ns
FRM Data Hold Time	tfH	30	-	ns

*1 CP Cycle is adjust so that FRM signal is 75Hz.

*2 Load cycle is const.

12. Supply Voltage Sequence Condition

Always follow the power supply ON / OFF sequence as specified below.

Unless you follow the power supply ON / OFF sequences, driving circuit in the LCD may irreparably break and / or DC voltage may be supplied to the LCD.

DC voltage induces irreversible electrochemical reactions on the screen and reduce LCD life.

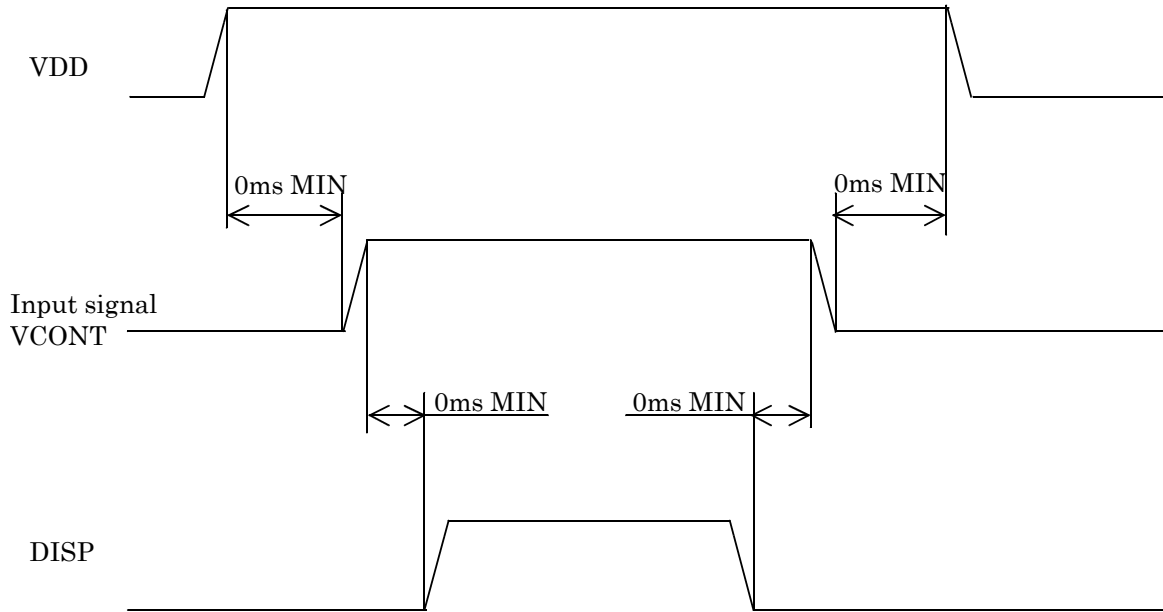

- * Input signal : CP, LOAD, FRM, D0~D7
Each signal (CP,LOAD,FRM) is constant.
- * The above sequence should be designed as to keep each normal figure on condition that liquid crystal module is loaded on your system.
- * Control the supply voltage sequence not to float all signal line when the LCD panel is driving.

13. LED Backlight Characteristics

13-1. LED Backlight Characteristics

Temp. = 25

ITEM	Symbol	MIN	TYP.	MAX	UNIT	NOTE
Supply voltage	VinB	3.0	-	5.5	V	0 ~ 50
ON-OFF (H)	BLEN	0.8VinB	-	VinB	V	-
ON-OFF (L)		0.0	-	0.2VinB		-
LED forward current *1	IF	9.0	10.0	11.0	mA	VBRT=0 ~ 0.8V
		-	(2.0)	-		VBRT=2.8V
Supply current	IinB	-	(290)	(350)	mA	VinB=3.3V, IF=10mA *1
		-	(180)	(220)		VinB=5.0V, IF=10mA *1
Operating Life *2	T	-	(50,000) *3	-	hour	IF=10mA *1

*1 Between AN1-CA1 and between AN2-CA2 each. (Please refer to below drawing.)

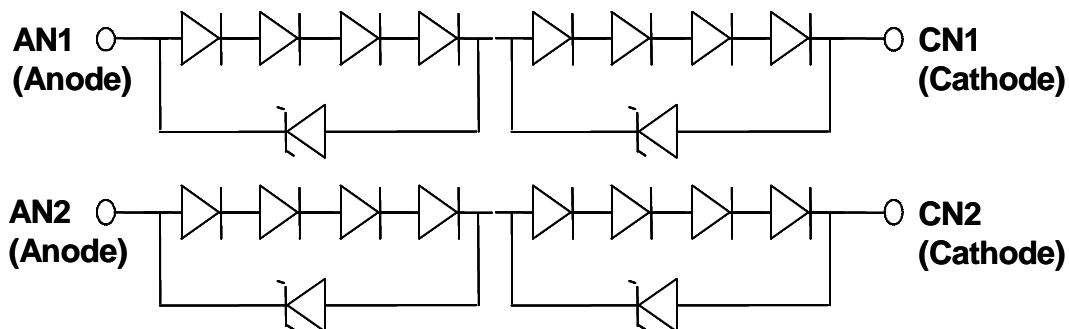

*2 When surface brightness decreases 50% of initial brightness .

*3 Life time is estimated data.

*4 When you start-up, please charge in sequence of VinB->BLEN, or VBRT.
When you shut-down, please stop in sequence of BLEN and/or VBRT->VinB.

*5 Please do not connect the other than our backlight to this output connector on the PCB.

*6 In case VDD and VIN are supplied by a single power source, VDD & VIN, and VSS & GND are connected directly and separately from the output on the power source. If the common wire are used for VDD & VIN, and for VSS & GND, and are split near the PCB, and connect to each LCD driving circuit and backlight driving circuit, a flicker might be occurred due to a ripple between the both circuit.

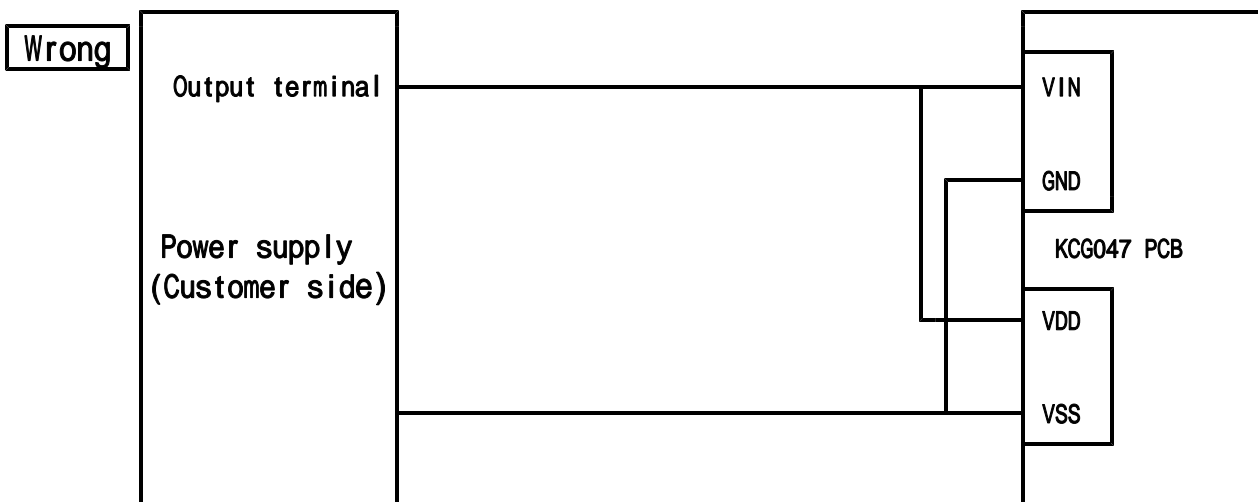
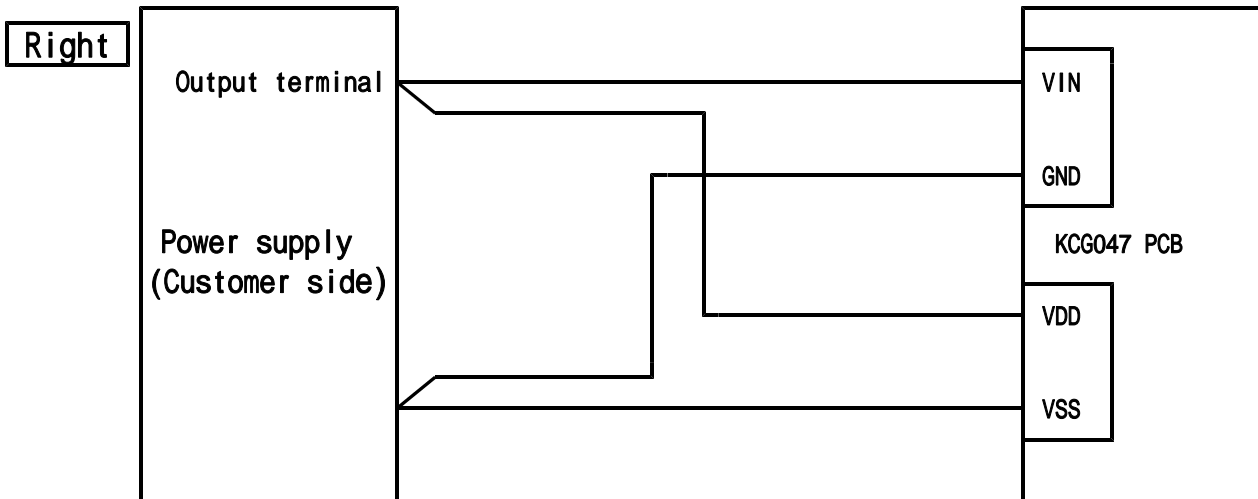

13-2. VBRT-IF characteristics

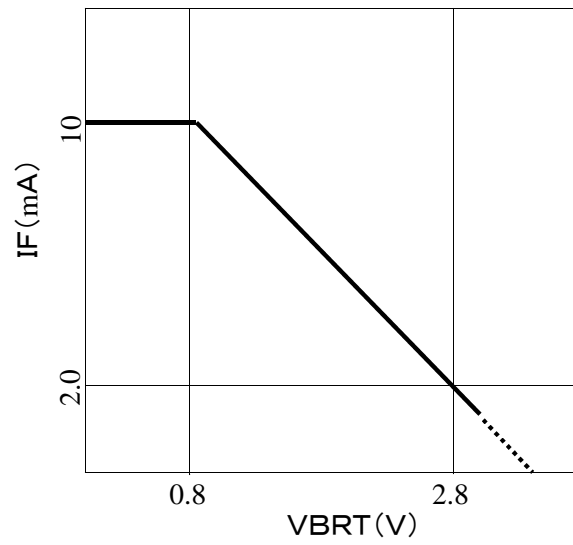

VBRT-IF characteristics (reference) Ta=25

1 4 . Design Guidance for Analog Touch-Panel(T/P)

14-1. Electrical

In customer's design, please remember the following considerations.

1. Do not use the current regulated circuit.
2. Keep the current limit with top and bottom layer.(See Sec, 4-1)
3. Analog T/P can not sense two point touching separately.
4. A contact resistance is appeared at the touch point between top and bottom layer.
After this resistance has stable read of the T/P position data.
5. Analog T/P is also a "Capacitor" in an equivalent circuit.
Design your sensing circuit and low-pass filter with considering this "Capacitor" value.
6. Because noise of inverter or peripheral circuits may interfere signal of touch panel itself
it is necessary to design carefully in advance to avoid these noise problem.

14-2. Software

1. Do the "User Calibration".
2. "User Calibration" may be needed with long term using.
Include "User Calibration" menu in your software.
3. When drawing a line with a stylus, there may be a slight discontinuity when the stylus passes over a spacer-dot. If necessary, please provide a compensation feature within your software.

14-3. Mounting on display and housing bezel

1. Do not use an adhesive tape to bond it on the front of T/P and hang it to the housing bezel.
2. Never expand the T/P top layer (PET-film) like a balloon by internal air pressure.
The life of the T/P will be extremely short.
3. If a dew will be on the heat-sealed area or exposed traces at the end of a flexible tail,
the migration of silver can occur.
This will cause sometimes a short circuit.

1 5 . Lot Number Identification

The lot number shall be indicated on the back of the backlight case of each LCD.

K C G 0 4 7 Q V L A E - G 0 0 - _____ - M A D E I N _____

Year
Month
Date
Version Number
Country or origin(Japan or China)

YEAR	2005	2006	2007	2008	2009	2010
CODE	5	6	7	8	9	0

MONTH	JAN.	FEB.	MAR.	APR.	MAY	JUN.
CODE	1	2	3	4	5	6

MONTH	JUL.	AUG.	SEP.	OCT.	NOV.	DEC.
CODE	7	8	9	X	Y	Z

1 6 . Warranty

16-1. Incoming inspection

Please inspect the LCD within one month after your receipt.

16-2. Production Warranty

Kyocera warrants its LCDs for a period of 12 months after receipt by the purchaser, and within the limits specified. Kyocera shall, by mutual agreement, replace or rework defective LCDs that are shown to be Kyocera's responsibility.

17 . Precautions for use

17-1. Installation of the LCD

1. Please ground of an LCD module, in order to stabilize brightness and display quality.
2. The LCD shall be installed so that there is no pressure on the LSI chips.
3. The LCD shall be installed flat, without twisting or bending.
4. The display window size should be the same as the effective viewing area.
5. In case you use outside frame of effective viewing area as outward appearance of your product, unevenness of its outward appearance is out of guarantee.
6. This Kyocera LCD module has been specifically designed for use in general electronic devices, but not for use in a special environment such as usage in an active gas.
Hence, when the LCD is supposed to be used in a special environment, evaluate the LCD thoroughly beforehand and do not expose the LCD to chemicals such as an active gas.

17-2. Static Electricity

1. Since CMOS ICs are mounted directly onto the LCD glass, protection from static electricity is required. Operation should wear ground straps.

17-3. LCD Operation

1. The LCD shall be operated within the limits specified. Operation at values outside of these limits may shorten life, and/or harm display images.
2. Adjust "LCD driving voltage" to obtain optimum viewing angle and contrast.
3. Operation of the LCD at temperature below the limit specified may cause image degradation and/or bubbles.
It may also change the characteristics of the liquid crystal.
This phenomenon may not recover. The LCD shall be operated within the temperature limits specified.

17-4. Storage

1. The LCD shall be stored within the temperature and humidity limits specified.
Store in a dark area, and protected the LCD from direct sunlight or fluorescent light.
2. Always store the LCD so that it is free from external pressure onto it.

17-5. Screen Surface

1. DO NOT store in a high humidity environment for extended periods.
Image degradation, bubbles, and/or peeling off of polarizer may result.
2. Do not push or rub the touch panel's surface with hard to sharp objects such as knives, or the touch panel may be scratched.
3. When the touch panel is dirty, gently wipe the surface with a soft cloth, sometimes moistened by mild detergent or alcohol. If a hazardous chemical is dropped on the touch panel by mistake, wipe it off right away to prevent human contact.
4. Touch panel edges are sharp. Handle the touch panel with enough care to prevent cuts.
5. Always keep the LCD free from condensation during testing.
Condensation may permanently spot or stain the polarizers.
6. Please do not use solid-base image pattern for long hours because a temporary afterimage may appear. We recommend to use screen saver etc. in cases where a solid-base image pattern must be used.
7. Liquid crystal may leak when the module is broken. Be careful not to let the fluid go into your eyes and mouth. In the case the fluid touches your body, rinse it off right away with water and soap.

1 8 . Reliability Data / Environmental Test

TEST ITEM	TEST CONDITION	TEST TIME	RESULT
High Temp. Atmosphere	(70)	(240 h)	Display Quality : No defect Display Function : No defect Current Consumption : No defect
Low Temp. Atmosphere	(-20)	(240 h)	Low Temp. Bubble : None Solid Crystallization of Liquid Crystal : None Display Quality : No defect Display Function : No defect Current Consumption : No defect
High Temp. Humidity Atmosphere	(40) (90%RH)	(240 h)	Display Quality : No defect Display Function : No defect Peel-off of Organic Sealing : None Current Consumption : No defect
Temp. Cycle	(-20 0.5 h) (R.T. 0.5 h) (70 0.5 h)	(10 cycles)	Display Quality : No defect Display Function : No defect Peel-off of Organic Sealing : None Bubble on Cell : None
High Temp. Operation	(50) (Vop)	(240 h)	Display Quality : No defect Display Function : No defect Current Consumption : No defect
Point Activation life	Polyacetal stylus (R0.8) Hitting force 3N Hitting speed 2 time/s	one million times	Display Quality : No defect Current Consumption : No defect

- * Each test item uses a test LCD only once. The tested LCD is not used in any other tests.
- * The LCD is tested in circumstances in which there is no condensation.
- * The tested LCD is inspected after 24 hours of storage at room temperature and room humidity after each test is finished.
- * The reliability test is not an out-going inspection.
- * The results of the reliability test are for your reference purpose only.
The reliability test is conducted only to examine the LCD's capability.

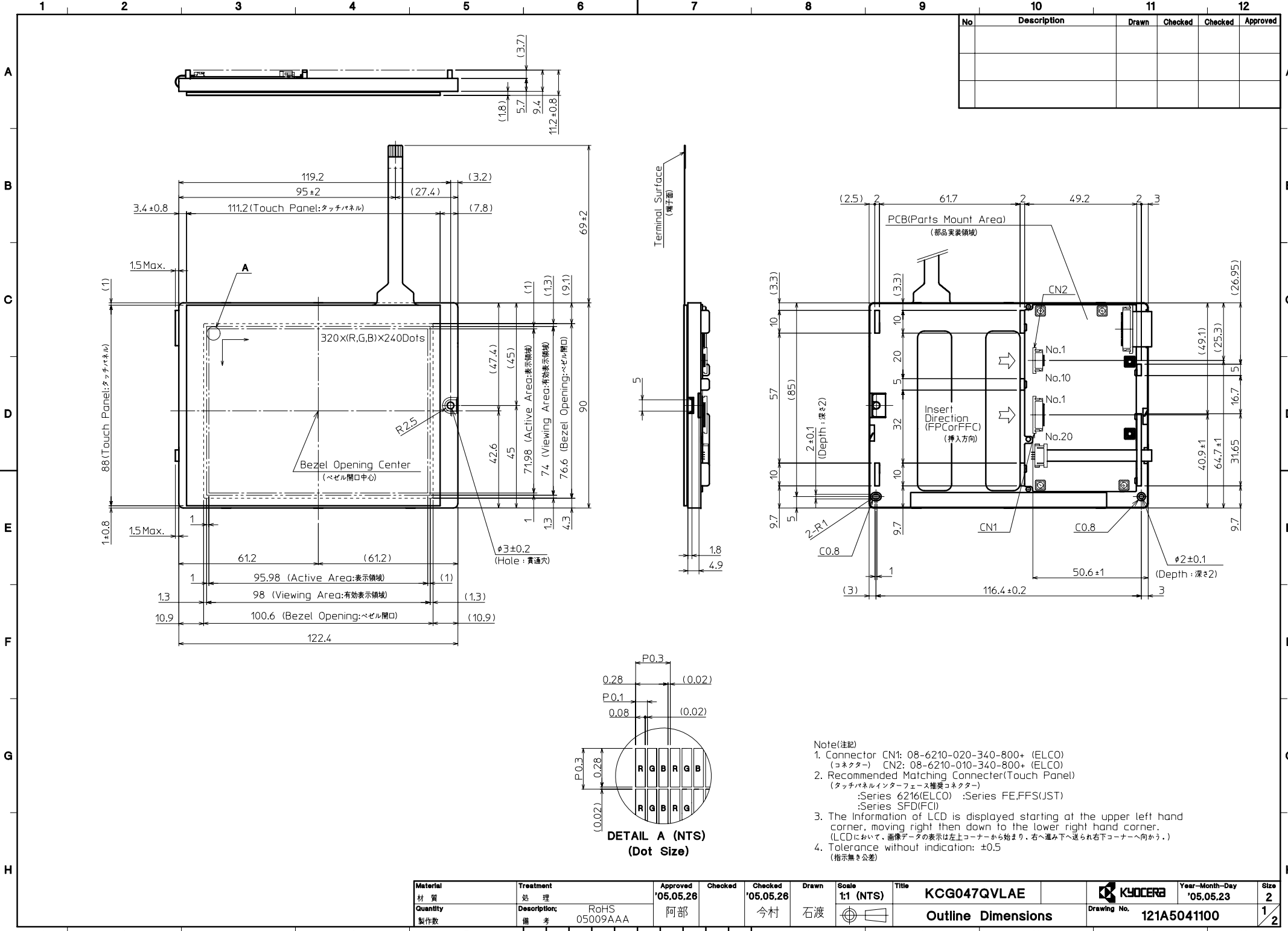

No	Description	Drawn	Checked	Checked	Approved

- Note(注記)
- Connector CN1: 08-6210-020-340-800+ (ELCO) (コネクタ) CN2: 08-6210-010-340-800+ (ELCO)
 - Recommended Matching Connector(Touch Panel) (タッチパネルインターフェース推奨コネクタ) :Series 6216(ELCO) :Series FE,FFS(JST) :Series SFD(FCI)
 - The information of LCD is displayed starting at the upper left hand corner, moving right then down to the lower right hand corner. (LCDにおいて、画像データの表示は左上コーナーから始まり、右へ進み下へ送られ右下コーナーへ向かう。)
 - Tolerance without indication: ± 0.5 (指示無き公差)

Material 材質	Treatment 処理	Approved '05.05.26	Checked	Checked '05.05.26	Drawn 石渡	Scale 1:1 (NTS)	Title KCG047QVLAE	KYOCERA Drawing No. 121A5041100	Year-Month-Day '05.05.23	Size 2
Quantity 製作数	Description: 備考	RoHS 05009AAA	阿部	今村	Outline Dimensions	121A5041100			1	2

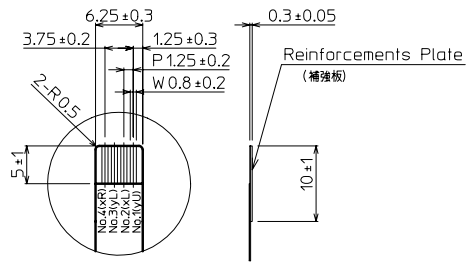

DETAIL B (2:1)

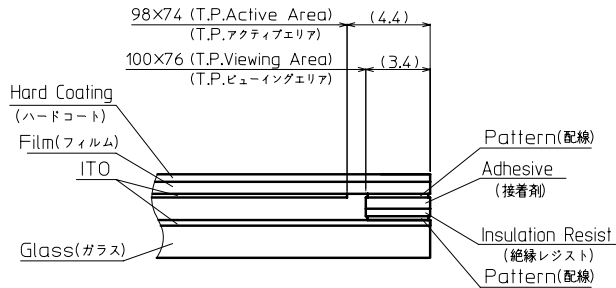

SECTION D-D(NTS)

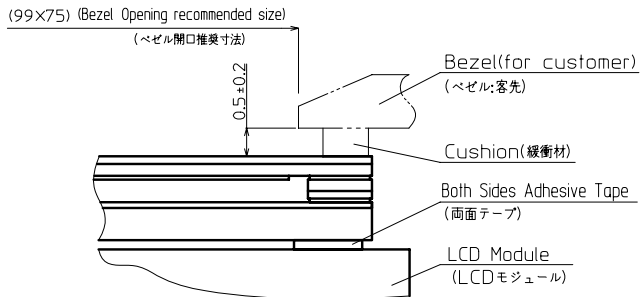

Precaution in use of touch panel.

- (タッチパネル使用上の注意事項)
- Fix touch panel at LCD module and the rear side of touch panel.
(タッチパネルの固定はLCDモジュール側とタッチパネル裏面とで行なうこと)
 - Must maintain a gap between inside of bezel and touch panel to avoid malfunction or electrode damage of touch panel.
(ベゼル内側とタッチパネルの接触厳禁。誤動作や電極破損の原因となります)
 - Please inform us beforehand when you design window of your housing with the different size from recommended size.
(ベゼル開口を推奨寸法以外で製作される場合は必ず前もって相談願います。)

Note(注記)

No	Name(名称)	Explanation(説明)
1	T.P.	Touch panel (タッチパネル)
2	T.P. Active Area (T.P. アクティブエリア)	Operating area of touch panel (タッチパネルの動作範囲)
3	T.P. Viewing Area (T.P. ビューイングエリア)	Warranty area of touch panel's appearance (タッチパネルの外観(傷・異物等)保証範囲) By giving pressure between the active area and the effective viewing area of the touch panel, there is a possibility that the touch panel will operate. (タッチパネルアクティブエリアとタッチパネルビューイングエリア間は荷重をかけた場合は、タッチパネルが動作する可能性があります。)

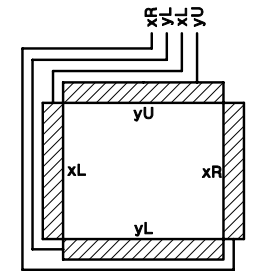
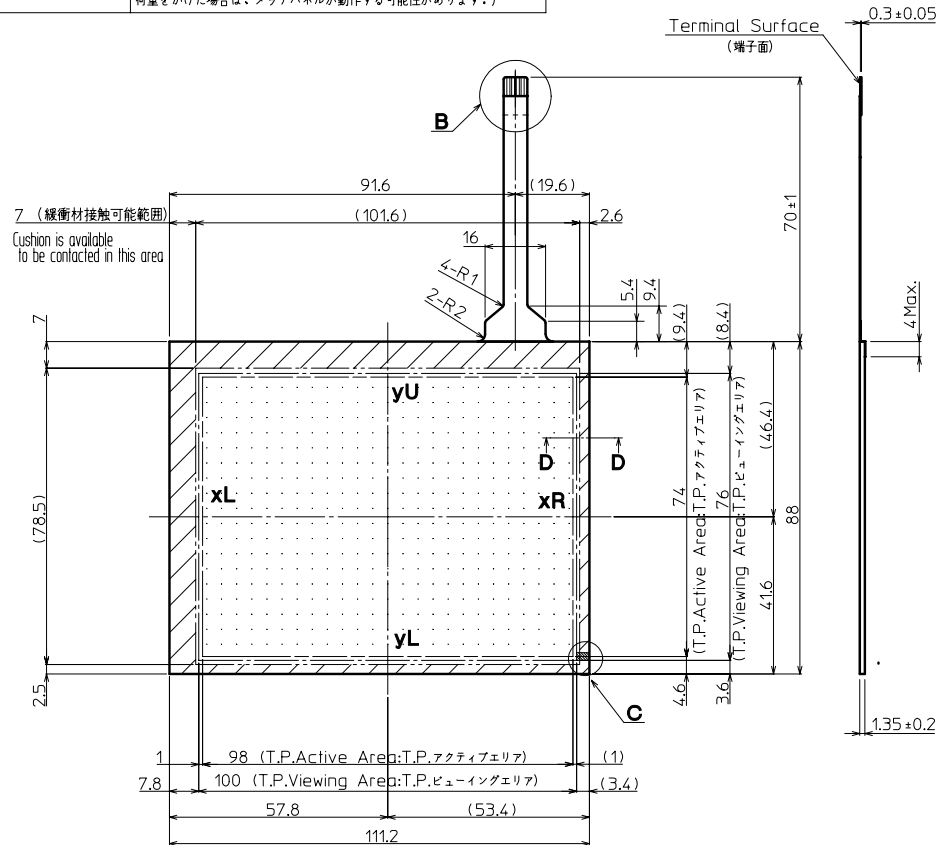

Touch Panel Pin-assign (タッチパネルピンアサイン)

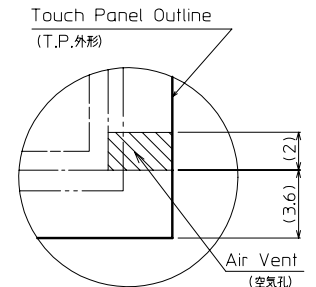

DETAIL C (5:1)

Precaution in use of touch panel.

- (タッチパネル使用上の注意事項)
- There is vent channel to equalize air pressure between the inner space of the touch panel and the atmosphere. Please make sure it is not blocked by your housing and mounting method.
(タッチパネルの中には内圧と外圧を均一にするため通気孔を設けています。取り付け時にこの通気孔を塞がないようにしてください。)

No	Description	Drawn	Checked	Checked	Approved

Material 材質	Treatment 処理	Approved '05.05.26	Checked	Checked '05.05.26	Drawn 石渡	Scale 1:1 (2.15:1 NTS)	Title KCG047QVLAE	KYOCERA Year-Month-Day '05.05.23	Size 2
Quantity 製作数	Description 備考 RoHS 05009AAA	阿部	今村			T.P. Outline Dimensions	Drawing No. 121A5041100		

SPEC. NO.	TQ3C-8EAC0-E2CUQ25-00
DATE	May 20, 2005

FOR : _____

KYOCERA INSPECTION STANDARD

TYPE : KCG047QVLAE-G00

KYOCERA CORPORATION
KAGOSHIMA HAYATO PLANT
LCD DIVISION

Original	Designed by :Engineering Dept.			Confirmed by :QA Dept.	
Issue Data	Prepared	Checked	Approved	Checked	Approved
May 20, 2005	<i>T. Andera</i>	<i>J. Yamagaki</i>	<i>M. Fujitani</i>	<i>J. Yoshida</i>	<i>N. Higashi</i>

Revision Record

Date	Designed by: Engineering Dept.			Confirmed by: QA Dept.	
	Prepared	Checked	Approved	Checked	Approved
Rev. No.	Date	Page	Descriptions		

Visuals specification

1)Note

Item	Note
General	<p>1. When defects specified in this Inspection Standards are inspected, operating voltage(Vop) shall be set at the level where optimized contrast is available. Display quality is applied up to effective viewing area. (Bi-Level INSPECTION)</p> <p>2. This inspection standard about the image quality shall be applied to any defect within the effective viewing area and shall not be applicable to outside of the area.</p> <p>3. Should any defects which are not specified in this standard happen, additional standard shall be determined by mutual agreement between customer and Kyocera.</p> <p>4. Inspection conditions</p> <p>Luminance : 500 Lux minimum . Inspection distance : 300 mm (from the sample) Temperature : 25 ± 5 °C Direction : right above</p>
Definition of Inspection item	<p>Pinhole, Bright spot Black spot, Scratch Foreign particle</p> <p>The color of a small area is different from the remainder. The phenomenon does not change with voltage.</p>
	<p>Contrast variation</p> <p>The color of a small area is different from the remainder. The phenomenon changes with voltage.</p>
	<p>Polarizer (Scratch, Bubble, Dent)</p> <p>Scratch, Bubble and Dent in the polarizer which can be observed in on / off state.</p>

2) Standard

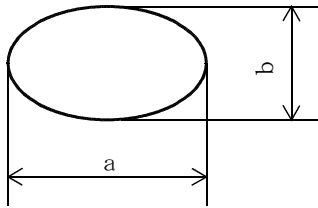
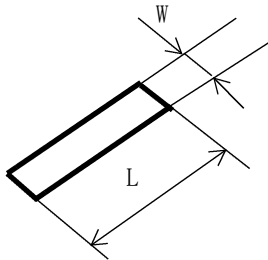
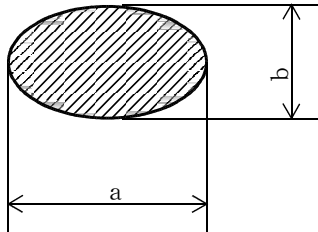
Inspection item	Judgement standard																						
Pinhole, Bright spot Black spot, Foreign particle (LCD portion)	<div style="text-align: center;">  $d = (a + b) / 2$ </div> <table border="1" style="width: 100%; border-collapse: collapse; margin-top: 10px;"> <thead> <tr> <th style="width: 15%;">Category</th> <th style="width: 35%;">Size (mm)</th> <th style="width: 50%;">Acceptable number</th> </tr> </thead> <tbody> <tr> <td style="text-align: center;">A</td> <td style="text-align: center;">$d \leq 0.2$</td> <td style="text-align: center;">neglected</td> </tr> <tr> <td style="text-align: center;">B</td> <td style="text-align: center;">$0.2 < d \leq 0.3$</td> <td style="text-align: center;">5</td> </tr> <tr> <td style="text-align: center;">C</td> <td style="text-align: center;">$0.3 < d \leq 0.5$</td> <td style="text-align: center;">3</td> </tr> <tr> <td style="text-align: center;">D</td> <td style="text-align: center;">$0.5 < d$</td> <td style="text-align: center;">0</td> </tr> </tbody> </table>	Category	Size (mm)	Acceptable number	A	$d \leq 0.2$	neglected	B	$0.2 < d \leq 0.3$	5	C	$0.3 < d \leq 0.5$	3	D	$0.5 < d$	0							
Category	Size (mm)	Acceptable number																					
A	$d \leq 0.2$	neglected																					
B	$0.2 < d \leq 0.3$	5																					
C	$0.3 < d \leq 0.5$	3																					
D	$0.5 < d$	0																					
Scratch, Foreign particle (LCD portion)	<div style="text-align: center;">  </div> <table border="1" style="width: 100%; border-collapse: collapse; margin-top: 10px;"> <thead> <tr> <th style="width: 5%;"></th> <th style="width: 25%;">Width (mm)</th> <th style="width: 25%;">Length (mm)</th> <th style="width: 45%;">Acceptable No.</th> </tr> </thead> <tbody> <tr> <td style="text-align: center;">A</td> <td style="text-align: center;">$W \leq 0.03$</td> <td style="text-align: center;">—</td> <td style="text-align: center;">neglected</td> </tr> <tr> <td style="text-align: center;">B</td> <td rowspan="3" style="text-align: center;">$0.03 < W \leq 0.1$</td> <td style="text-align: center;">$L \leq 2.0$</td> <td style="text-align: center;">neglected</td> </tr> <tr> <td style="text-align: center;">C</td> <td style="text-align: center;">$2.0 < L \leq 4.0$</td> <td style="text-align: center;">3</td> </tr> <tr> <td style="text-align: center;">D</td> <td style="text-align: center;">$4.0 < L$</td> <td style="text-align: center;">0</td> </tr> <tr> <td style="text-align: center;">E</td> <td style="text-align: center;">$0.1 < W$</td> <td style="text-align: center;">—</td> <td style="text-align: center;">According to Circular</td> </tr> </tbody> </table>		Width (mm)	Length (mm)	Acceptable No.	A	$W \leq 0.03$	—	neglected	B	$0.03 < W \leq 0.1$	$L \leq 2.0$	neglected	C	$2.0 < L \leq 4.0$	3	D	$4.0 < L$	0	E	$0.1 < W$	—	According to Circular
	Width (mm)	Length (mm)	Acceptable No.																				
A	$W \leq 0.03$	—	neglected																				
B	$0.03 < W \leq 0.1$	$L \leq 2.0$	neglected																				
C		$2.0 < L \leq 4.0$	3																				
D		$4.0 < L$	0																				
E	$0.1 < W$	—	According to Circular																				
Contrast variation	<div style="text-align: center;">  $d = (a + b) / 2$ </div> <table border="1" style="width: 100%; border-collapse: collapse; margin-top: 10px;"> <thead> <tr> <th style="width: 15%;">Category</th> <th style="width: 35%;">Size (mm)</th> <th style="width: 50%;">Acceptable number</th> </tr> </thead> <tbody> <tr> <td style="text-align: center;">A</td> <td style="text-align: center;">$d \leq 0.5$</td> <td style="text-align: center;">neglected</td> </tr> <tr> <td style="text-align: center;">B</td> <td style="text-align: center;">$0.5 < d \leq 0.7$</td> <td style="text-align: center;">3</td> </tr> <tr> <td style="text-align: center;">C</td> <td style="text-align: center;">$0.7 < d$</td> <td style="text-align: center;">0</td> </tr> </tbody> </table>	Category	Size (mm)	Acceptable number	A	$d \leq 0.5$	neglected	B	$0.5 < d \leq 0.7$	3	C	$0.7 < d$	0										
Category	Size (mm)	Acceptable number																					
A	$d \leq 0.5$	neglected																					
B	$0.5 < d \leq 0.7$	3																					
C	$0.7 < d$	0																					

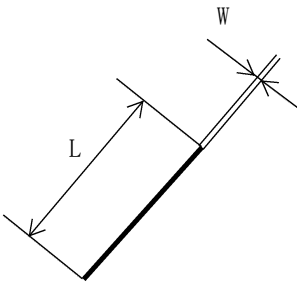
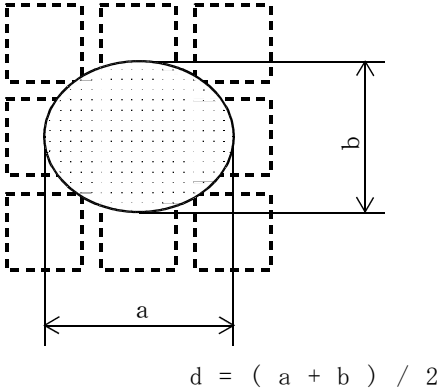
Inspection item	Judgement standard																			
Polarizer (Scratch, Bubble, Dent)	<p data-bbox="544 248 708 277">(1) Scratch</p>  <table border="1" data-bbox="544 689 1422 1021"> <thead> <tr> <th></th> <th>Width (mm)</th> <th>Length (mm)</th> <th>Acceptable No.</th> </tr> </thead> <tbody> <tr> <td>A</td> <td>$W \leq 0.1$</td> <td>—</td> <td>neglected</td> </tr> <tr> <td>B</td> <td rowspan="2">$0.1 < W \leq 0.3$</td> <td>$L \leq 5.0$</td> <td>neglected</td> </tr> <tr> <td>C</td> <td>$5.0 < L$</td> <td>0</td> </tr> <tr> <td>D</td> <td>$0.3 < W$</td> <td>—</td> <td>0</td> </tr> </tbody> </table>		Width (mm)	Length (mm)	Acceptable No.	A	$W \leq 0.1$	—	neglected	B	$0.1 < W \leq 0.3$	$L \leq 5.0$	neglected	C	$5.0 < L$	0	D	$0.3 < W$	—	0
	Width (mm)	Length (mm)	Acceptable No.																	
A	$W \leq 0.1$	—	neglected																	
B	$0.1 < W \leq 0.3$	$L \leq 5.0$	neglected																	
C		$5.0 < L$	0																	
D	$0.3 < W$	—	0																	
	<p data-bbox="544 1070 807 1099">(2)Bubble (dent)</p>  <table border="1" data-bbox="544 1675 1393 2007"> <thead> <tr> <th>Category</th> <th>Size (mm)</th> <th>Acceptable number</th> </tr> </thead> <tbody> <tr> <td>A</td> <td>$d \leq 0.2$</td> <td>neglected</td> </tr> <tr> <td>B</td> <td>$0.2 < d \leq 0.3$</td> <td>5</td> </tr> <tr> <td>C</td> <td>$0.3 < d \leq 0.5$</td> <td>3</td> </tr> <tr> <td>D</td> <td>$0.5 < d$</td> <td>0</td> </tr> </tbody> </table>	Category	Size (mm)	Acceptable number	A	$d \leq 0.2$	neglected	B	$0.2 < d \leq 0.3$	5	C	$0.3 < d \leq 0.5$	3	D	$0.5 < d$	0				
Category	Size (mm)	Acceptable number																		
A	$d \leq 0.2$	neglected																		
B	$0.2 < d \leq 0.3$	5																		
C	$0.3 < d \leq 0.5$	3																		
D	$0.5 < d$	0																		

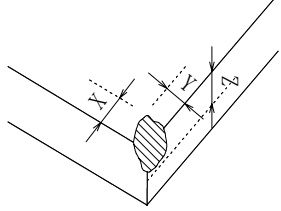
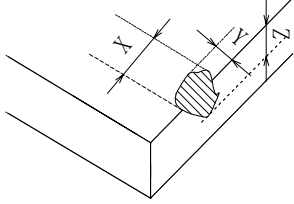
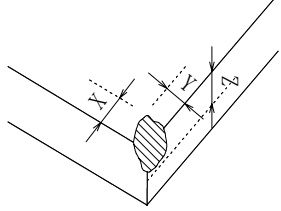
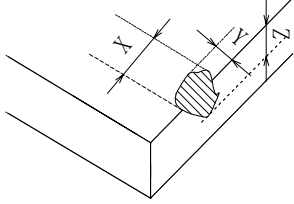
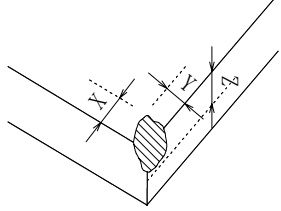
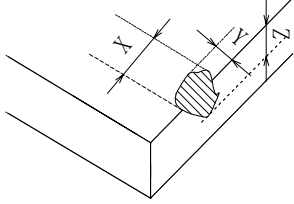
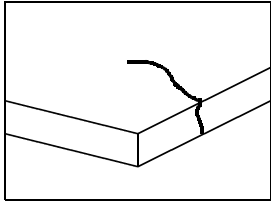
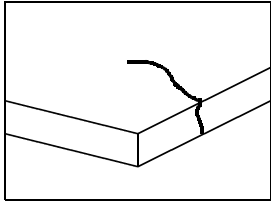
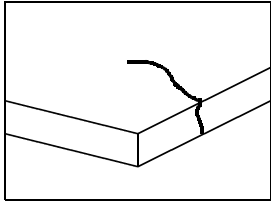
Inspection item	Judgement standard																																																					
Scratch, Foreign particle (Touch Screen portion)	$(D = \text{Average Diameter} = (\text{major axis} + \text{minor axis}) / 2$																																																					
	<table border="1" style="width: 100%; border-collapse: collapse;"> <thead> <tr> <th style="width: 15%;"></th> <th style="width: 20%;">Width(mm)</th> <th style="width: 20%;">Length(mm)</th> <th colspan="3">Acceptable No.</th> </tr> </thead> <tbody> <tr> <td rowspan="4" style="text-align: center; vertical-align: middle;">Scratch</td> <td style="text-align: center;">$0.1 \geq W > 0.08$</td> <td style="text-align: center;">$4 \geq L$</td> <td colspan="3" style="text-align: center;">1pcs within $\phi 30\text{mm}$</td> </tr> <tr> <td style="text-align: center;">$0.08 \geq W > 0.05$</td> <td style="text-align: center;">$6 \geq L$</td> <td colspan="3" style="text-align: center;">2pcs within $\phi 20\text{mm}$</td> </tr> <tr> <td style="text-align: center;">$0.05 \geq W > 0.03$</td> <td style="text-align: center;">$10 \geq L$</td> <td colspan="3" style="text-align: center;">2pcs within $\phi 20\text{mm}$</td> </tr> <tr> <td style="text-align: center;">$0.03 \geq W$</td> <td style="text-align: center;">$20 \geq L$</td> <td colspan="3" style="text-align: center;">neglected</td> </tr> <tr> <td rowspan="2" style="text-align: center; vertical-align: middle;">Foreign (line like)</td> <td style="text-align: center;">$0.1 \geq W > 0.05$</td> <td style="text-align: center;">$5 \geq L$</td> <td colspan="3" style="text-align: center;">2pcs within $\phi 30\text{mm}$</td> </tr> <tr> <td style="text-align: center;">$0.05 \geq W$</td> <td style="text-align: center;">neglected</td> <td colspan="3" style="text-align: center;">neglected</td> </tr> <tr> <td rowspan="2" style="text-align: center; vertical-align: middle;">Foreign (circle like)</td> <td colspan="2" style="text-align: center;">$0.3 \geq D > 0.2$</td> <td colspan="3" style="text-align: center;">2pcs within $\phi 30\text{mm}$</td> </tr> <tr> <td colspan="2" style="text-align: center;">$0.2 \geq D$</td> <td colspan="3" style="text-align: center;">neglected</td> </tr> </tbody> </table> <p data-bbox="528 678 1445 813"> Above are applied to the visible area. Unless there are foreign particles and damage affected seriously to the electrical performance in the visible area, we approve of this product. </p>							Width(mm)	Length(mm)	Acceptable No.			Scratch	$0.1 \geq W > 0.08$	$4 \geq L$	1pcs within $\phi 30\text{mm}$			$0.08 \geq W > 0.05$	$6 \geq L$	2pcs within $\phi 20\text{mm}$			$0.05 \geq W > 0.03$	$10 \geq L$	2pcs within $\phi 20\text{mm}$			$0.03 \geq W$	$20 \geq L$	neglected			Foreign (line like)	$0.1 \geq W > 0.05$	$5 \geq L$	2pcs within $\phi 30\text{mm}$			$0.05 \geq W$	neglected	neglected			Foreign (circle like)	$0.3 \geq D > 0.2$		2pcs within $\phi 30\text{mm}$			$0.2 \geq D$		neglected	
	Width(mm)	Length(mm)	Acceptable No.																																																			
Scratch	$0.1 \geq W > 0.08$	$4 \geq L$	1pcs within $\phi 30\text{mm}$																																																			
	$0.08 \geq W > 0.05$	$6 \geq L$	2pcs within $\phi 20\text{mm}$																																																			
	$0.05 \geq W > 0.03$	$10 \geq L$	2pcs within $\phi 20\text{mm}$																																																			
	$0.03 \geq W$	$20 \geq L$	neglected																																																			
Foreign (line like)	$0.1 \geq W > 0.05$	$5 \geq L$	2pcs within $\phi 30\text{mm}$																																																			
	$0.05 \geq W$	neglected	neglected																																																			
Foreign (circle like)	$0.3 \geq D > 0.2$		2pcs within $\phi 30\text{mm}$																																																			
	$0.2 \geq D$		neglected																																																			
Glass crack (Touch Screen portion)	<table border="1" style="width: 100%; border-collapse: collapse;"> <thead> <tr> <th rowspan="3" style="width: 15%; text-align: center; vertical-align: middle;">Judgement standard</th> <th colspan="3" style="text-align: center;">Corner crack</th> <th colspan="3" style="text-align: center;">Cracks in other area than in corner</th> </tr> </thead> <tbody> <tr> <td colspan="3" style="text-align: center;"></td> <td colspan="3" style="text-align: center;"></td> </tr> <tr> <td style="text-align: center;">X</td> <td style="text-align: center;">Y</td> <td style="text-align: center;">Z</td> <td style="text-align: center;">X</td> <td style="text-align: center;">Y</td> <td style="text-align: center;">Z</td> </tr> <tr> <td style="text-align: center;">≤ 3</td> <td style="text-align: center;">≤ 3</td> <td style="text-align: center;">$< t$</td> <td style="text-align: center;">≤ 5</td> <td style="text-align: center;">≤ 1.5</td> <td style="text-align: center;">$< t$</td> </tr> <tr> <td colspan="3" style="text-align: center;">2pcs/panel</td> <td colspan="3" style="text-align: center;">2pcs/side</td> </tr> </tbody> </table>						Judgement standard	Corner crack			Cracks in other area than in corner									X	Y	Z	X	Y	Z	≤ 3	≤ 3	$< t$	≤ 5	≤ 1.5	$< t$	2pcs/panel			2pcs/side																			
	Judgement standard	Corner crack			Cracks in other area than in corner																																																	
																																																						
X		Y	Z	X	Y	Z																																																
≤ 3	≤ 3	$< t$	≤ 5	≤ 1.5	$< t$																																																	
2pcs/panel			2pcs/side																																																			
<table border="1" style="width: 100%; border-collapse: collapse;"> <thead> <tr> <th style="width: 15%; text-align: center; vertical-align: middle;">Judgement standard</th> <th style="text-align: center;">Progressive crack</th> </tr> </thead> <tbody> <tr> <td></td> <td style="text-align: center;"></td> </tr> <tr> <td></td> <td style="text-align: center;">0pcs (NG even 1pcs)</td> </tr> </tbody> </table>						Judgement standard	Progressive crack				0pcs (NG even 1pcs)																																											
Judgement standard	Progressive crack																																																					
																																																						
	0pcs (NG even 1pcs)																																																					
<p data-bbox="528 1872 1445 2007"> Above are applied to the visible area. Unless there are foreign particles and damage affected seriously to the electrical performance in the visible area, we approve of this product. </p>																																																						