

# SPEC

Spec No.	TQ3C-8EAC0-E1DDV11-00
Date	February 20, 2007

**TYPE : KCG057QV1DB-G500**  
< 5.7 inch QVGA transmissive color STN >

## CONTENTS

1. Application
2. Construction and outline
3. Mechanical specification
4. Absolute maximum ratings
5. Electrical characteristics
6. Optical characteristics
7. Circuit block diagram
8. Interface signals
9. Interface timing chart
10. Data and screen
11. Input timing characteristics
12. Supply voltage sequence condition
13. Backlight characteristics
14. Lot number identification
15. Warranty
16. Precaution for use
17. Reliability data
18. Outline drawing



KYOCERA CORPORATION  
KAGOSHIMA HAYATO PLANT  
LCD DIVISION

This specification is subject to change without notice.  
Consult Kyocera before ordering.

Original Issue Date	Designed by: Engineering dept.			Confirmed by: QA dept.	
	Prepared	Checked	Approved	Checked	Approved
February 20, 2007	<i>Y. Asano</i>	<i>F. Yamaguchi</i>	<i>Y. Matsumoto</i>	<i>J. Sakaguchi</i>	<i>Ho. Itoh</i>

Spec No. TQ3C-8EAC0-E1DDV11-00	Part No. KCG057QV1DB-G500	Page -
-----------------------------------	------------------------------	-----------

---

## **Warning**

1. This Kyocera LCD module has been specifically designed for use only in electronic devices and industrial machines in the area of audio control, office automation, industrial control home appliances, etc. The module should not be used in applications where the highest level of safety and reliability are required and module failure or malfunction of such module results in physical harm or loss of life, as well as enormous damage or loss. Such fields of applications include, without limitation, medical, aerospace, communications infrastructure, atomic energy control. Kyocera expressly disclaims any and all liability resulting in any way to the use of the module In such applications.
  
2. Customer agrees to indemnity, defend and hold Kyocera harmless from and against any and all actions, claims, damages, liabilities, awards, costs, and expenses, including legal expenses, resulting from or arising out of Customer's use, or sale for use, or Kyocera modules in applications.

## **Caution**

1. Kyocera shall have the right, which Customer hereby acknowledges, to immediately scrap or destroy tooling for Kyocera modules for which no Purchase Orders have been received from the Customer in a two-year period.

Spec No. TQ3C-8EAC0-E1DDV11-00	Part No. KCG057QV1DB-G500	Page -
-----------------------------------	------------------------------	-----------

**Revision record**

Date	Designed by : Engineering dept.			Confirmed by : QA dept.	
	Prepared	Checked	Approved	Checked	Approved

Rev.No.	Date	Page	Descriptions

## 1. Application

This document defines the specification of KCG057QV1DB-G500. (RoHS Compliant)

## 2. Construction and outline

LCD	: Transmissive color dot matrix type STN
Duty ratio	: 1/240 duty
Backlight system	: CFL (1 tube, U-figure type)
Inverter	: Option
Recommended inverter	: CXA-L0612A-VJL (TDK) or equivalent
Polarizer	: Glare treatment
Additional circuit	: Bias voltage circuit, Randomizing circuit, DC/DC converter circuit, Temperature compensation circuit

## 3. Mechanical specifications

Item	Specification	Unit
Outline dimensions	144 (W) × (104.8) (H) × 12.7 (D)	mm
Active area	115.18 (W) × 86.38 (H) (14.4cm / 5.7 inch (Diagonal))	mm
Effective viewing area	117.2 (W) × 88.4 (H)	mm
Dot format	320 × (R,G,B) (W) × 240 (H)	dot
Dot size	0.10 (W) × 0.34 (H)	mm
Dot pitch	0.12 (W) × 0.36 (H)	mm
Base color *1	Normally Black	-
Mass	175	g

\*1 Due to the characteristics of the LCD material, the color varies with environmental temperature.

## 4. Absolute maximum ratings

### 4-1. Electrical absolute maximum ratings

Item	Symbol	Min.	Max.	Unit
Supply voltage for logic	V <sub>DD</sub>	0	6.0	V
Supply voltage for LCD driving	V <sub>CONT</sub>	0	V <sub>DD</sub>	V
Input signal voltage *1	V <sub>IN</sub>	0	V <sub>DD</sub>	V
FRM frequency	f <sub>FRM</sub>	-	150	Hz

\*1 Input signal : FRM, LOAD, CP, DISP, D0~D7

### 4-2. Environmental absolute maximum ratings

Item	Symbol	Min.	Max.	Unit
Operating temperature *1	T <sub>OP</sub>	0	60	°C
Storage temperature *2	T <sub>STO</sub>	-20	60	°C
Operating humidity *3	H <sub>OP</sub>	10	*4	%RH
Storage humidity *3	H <sub>STO</sub>	10	*4	%RH
Vibration	-	*5	*5	-
Shock	-	*6	*6	-

\*1 Operating temperature means a temperature which operation shall be guaranteed. Since display performance is evaluated at 25°C, another temperature range should be confirmed.

\*2 Temp. = -20°C < 48h , Temp. = 60°C < 168h

Store LCD panels at normal temperature/humidity. Keep them free from vibration and shock. An LCD panel that is kept at a low or a high temperature for a long time can be defective due to other conditions, even if the low or high temperature satisfies the standard. (Please refer to "Precautions for Use" for details.)

\*3 Non-condensing

\*4 Temp. ≤ 40°C, 85%RH Max.

Temp. > 40°C, Absolute humidity shall be less than 85%RH at 40°C.

\*5

Frequency	10~55 Hz	Acceleration value (0.3~9 m/s <sup>2</sup> )
Vibration width	0.15mm	
Interval	10-55-10 Hz	1 minutes

2 hours in each direction X, Y, Z (6 hours total)

EIAJ ED-2531

\*6 Acceleration: 490 m/s<sup>2</sup>, Pulse width: 11 ms

3 times in each direction: ±X, ±Y, ±Z

EIAJ ED-2531





## 6. Optical characteristics

Measuring spot =  $\phi$  6.0mm, Temp. = 25°C

Item		Symbol	Condition	Min.	Typ.	Max.	Unit
Response time	Rise	$\tau_r$	$\theta = \phi = 0^\circ$	-	180	280	ms
	Down	$\tau_d$	$\theta = \phi = 0^\circ$	-	170	270	ms
Viewing angle range	$\theta$ UPPER	CR $\geq$ 2	$\theta = \phi = 0^\circ$	-	20	-	deg.
	$\theta$ LOWER			-	35	-	
	$\phi$ LEFT			-	50	-	deg.
	$\phi$ RIGHT			-	50	-	
Contrast ratio	CR	$\theta = \phi = 0^\circ$	30	55	-	-	
Brightness	L	IL=4.0mA <sub>rms</sub>	300	400	-	cd/m <sup>2</sup>	
Chromaticity coordinates	Red	x	$\theta = \phi = 0^\circ$	0.50	0.55	0.60	-
		y		0.28	0.33	0.38	
	Green	x	$\theta = \phi = 0^\circ$	0.24	0.29	0.34	
		y		0.44	0.49	0.54	
	Blue	x	$\theta = \phi = 0^\circ$	0.10	0.15	0.20	
		y		0.07	0.12	0.17	
	White	x	$\theta = \phi = 0^\circ$	0.25	0.30	0.35	
		y		0.25	0.30	0.35	

Optimum contrast is obtained by adjusting the LCD driving voltage ( $V_{OP}$ ) while at the viewing angle of  $\theta = \phi = 0^\circ$ .

### 6-1. Definition of contrast ratio

$$CR(\text{Contrast ratio}) = \frac{\text{Brightness with all pixels "White"}}{\text{Brightness with all pixels "Black"}}$$

### 6-2. Definition of $V_{OP}$

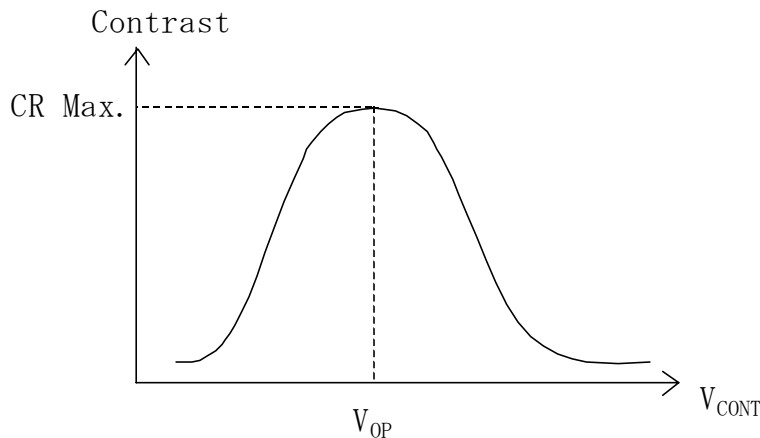



6-3. Definition of response time

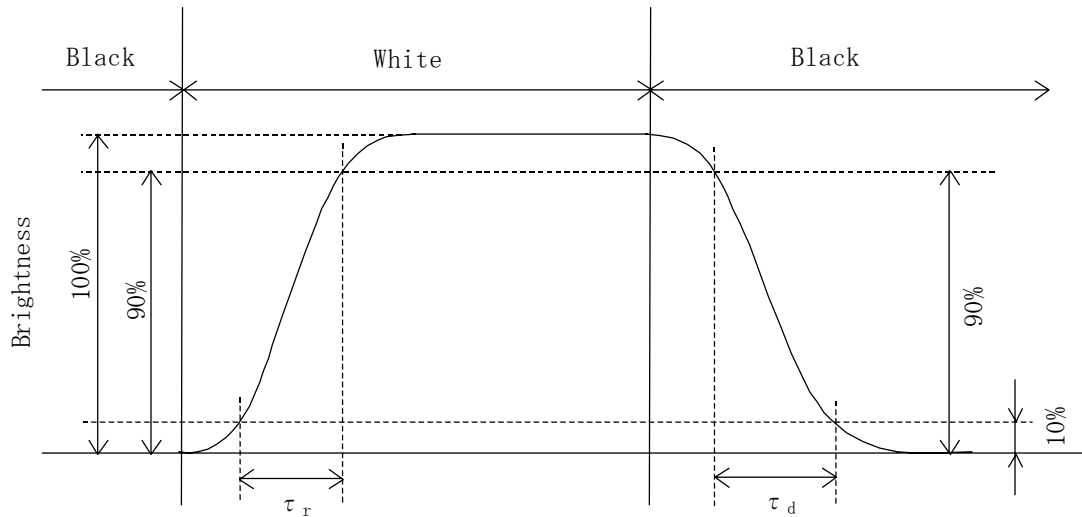

6-4. Definition of viewing angle

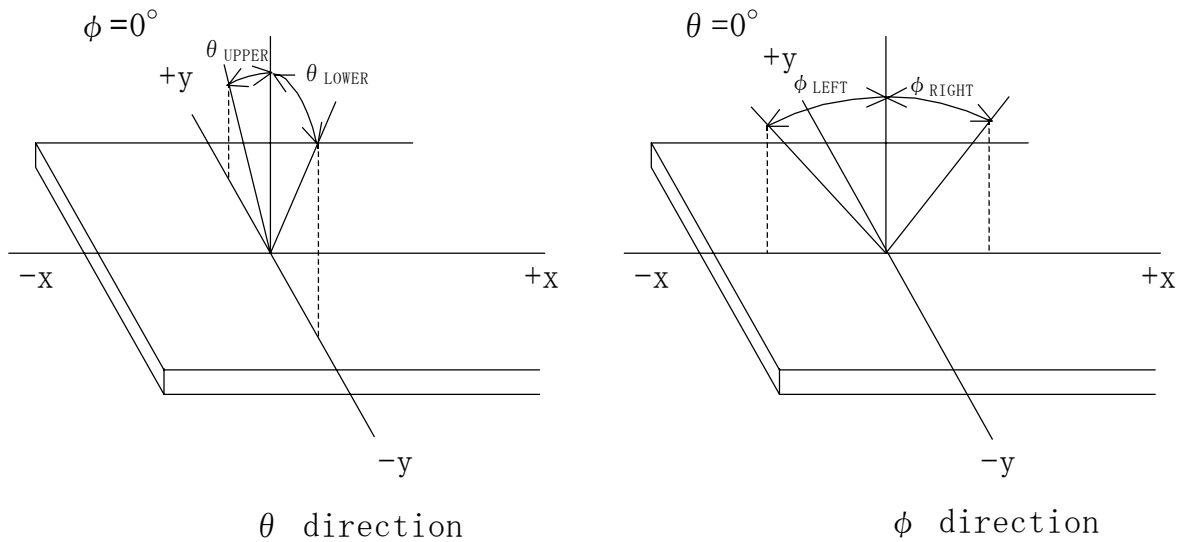

6-5. Brightness measuring points

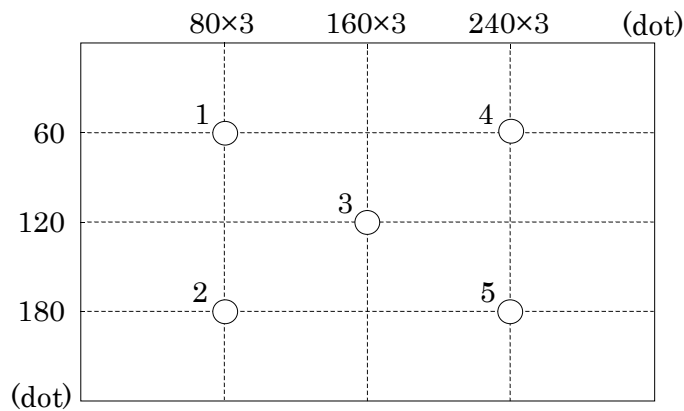

- 1) Rating is defined on the average in the viewing area.
- 2) Measured 30 minutes after the CFL is powered on. (Ambient temp. = 25°C)
- 3) The inverter should meet the CFL rating in the specification:
  - Sine, symmetric waveform without spike in positive and negative.

## 7. Circuit block diagram

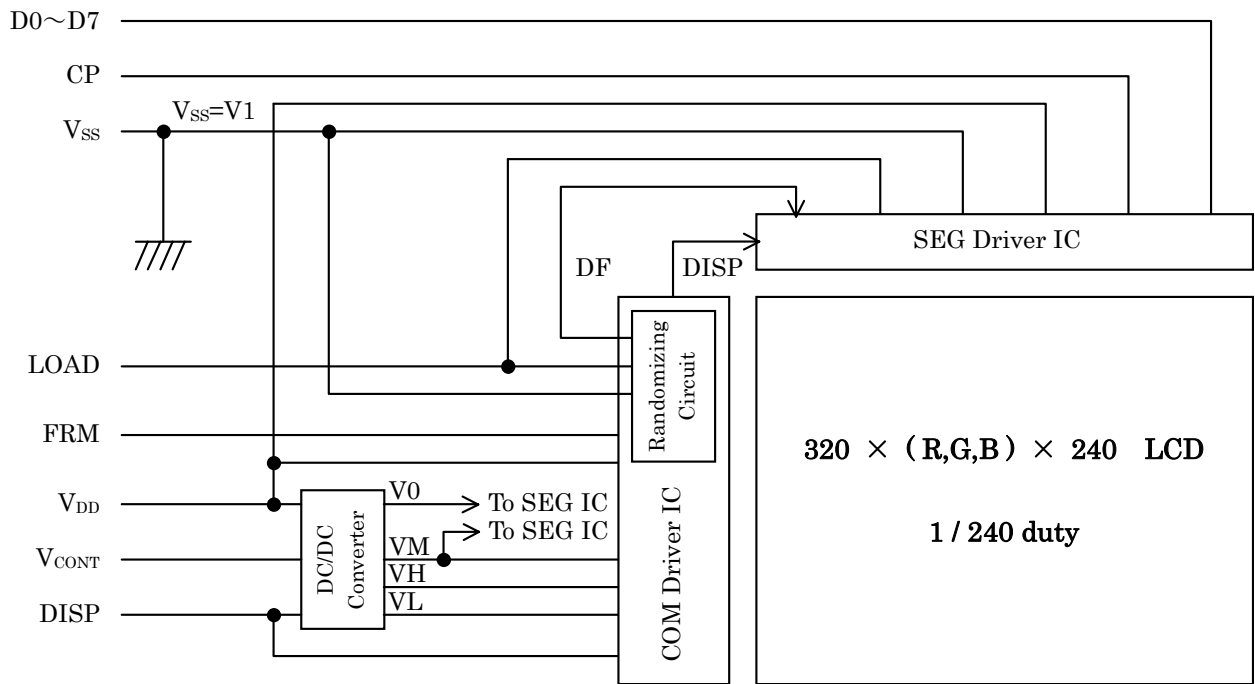

### 7-1. Power supply

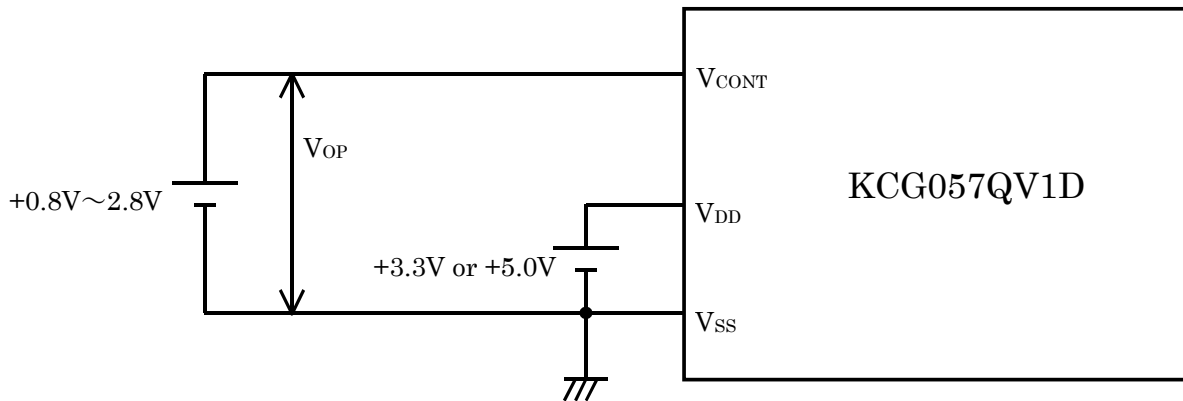

## 8. Interface

### 8-1. Pin assignment of LCD panel

No.	Symbol	Description	Level
1	FRM	Synchronous signal for driving scanning line	H
2	LOAD	Data signal latch clock	H → L
3	CP	Data signal shift clock	H → L
4	DISP	Display control signal	H(ON),L(OFF)
5	V <sub>DD</sub>	Power supply for logic	-
6	V <sub>SS</sub>	GND	-
7	V <sub>CONT</sub>	LCD adjust voltage	-
8	D7	Display data	H(ON),L(OFF)
9	D6		
10	D5		
11	D4		
12	D3		
13	D2		
14	D1		
15	D0		
16	V <sub>DD</sub>	Power supply for logic	-
17	V <sub>DD</sub>		
18	V <sub>SS</sub>	GND	-
19	V <sub>SS</sub>		
20	V <sub>SS</sub>		

LCD connector : 08-6210-020-340-800+ (ELCO)

Recommended matching FFC or FPC : 0.5mm pitch

### 8-2. Pin assignment of CFL

No.	Symbol	Description
1	Hot	Inverter output high voltage side
2	N.C.	-
3	Cold	Inverter output low voltage side

LCD side connector : BHR-03VS-1 (JST)

Recommended matching connector

: SM02(8.0)B-BHS-1 (JST)

: SM02(8.0)B-BHS-1-TB(LF)(SN) (JST)···(RoHS Compliant)

### 9. Interface timing chart

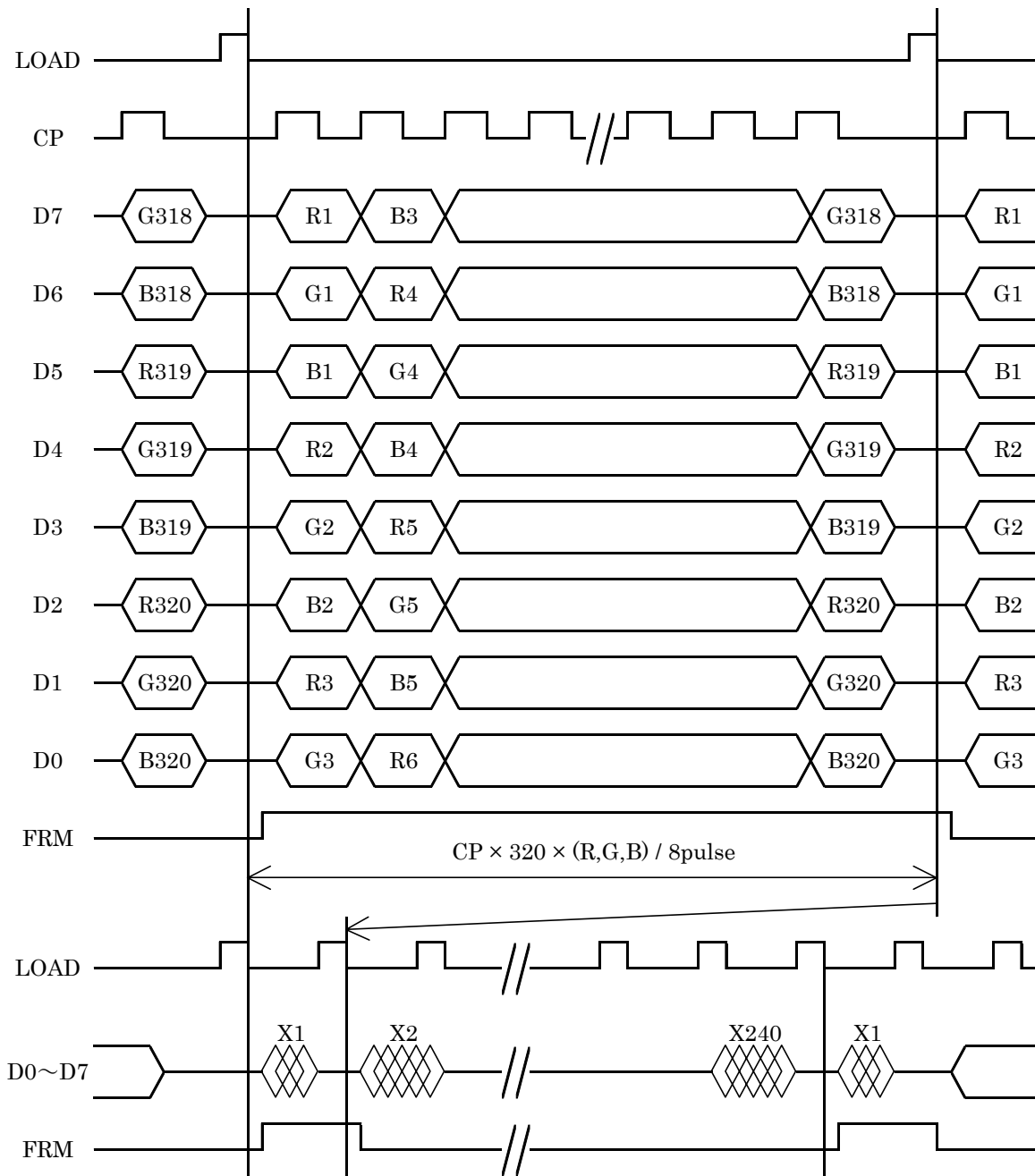

- \* The cycle of the LOAD signal should be stable and continuously applied without interruption.
- \* The above-mentioned timing chart is a reference to set up a LCD module, not an electrical rating.

### 10. Data and screen

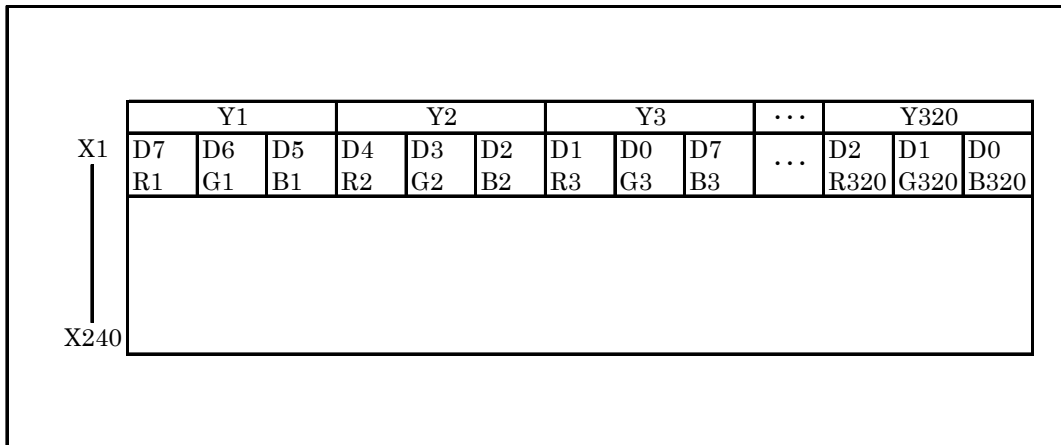

### 11. Input timing characteristics

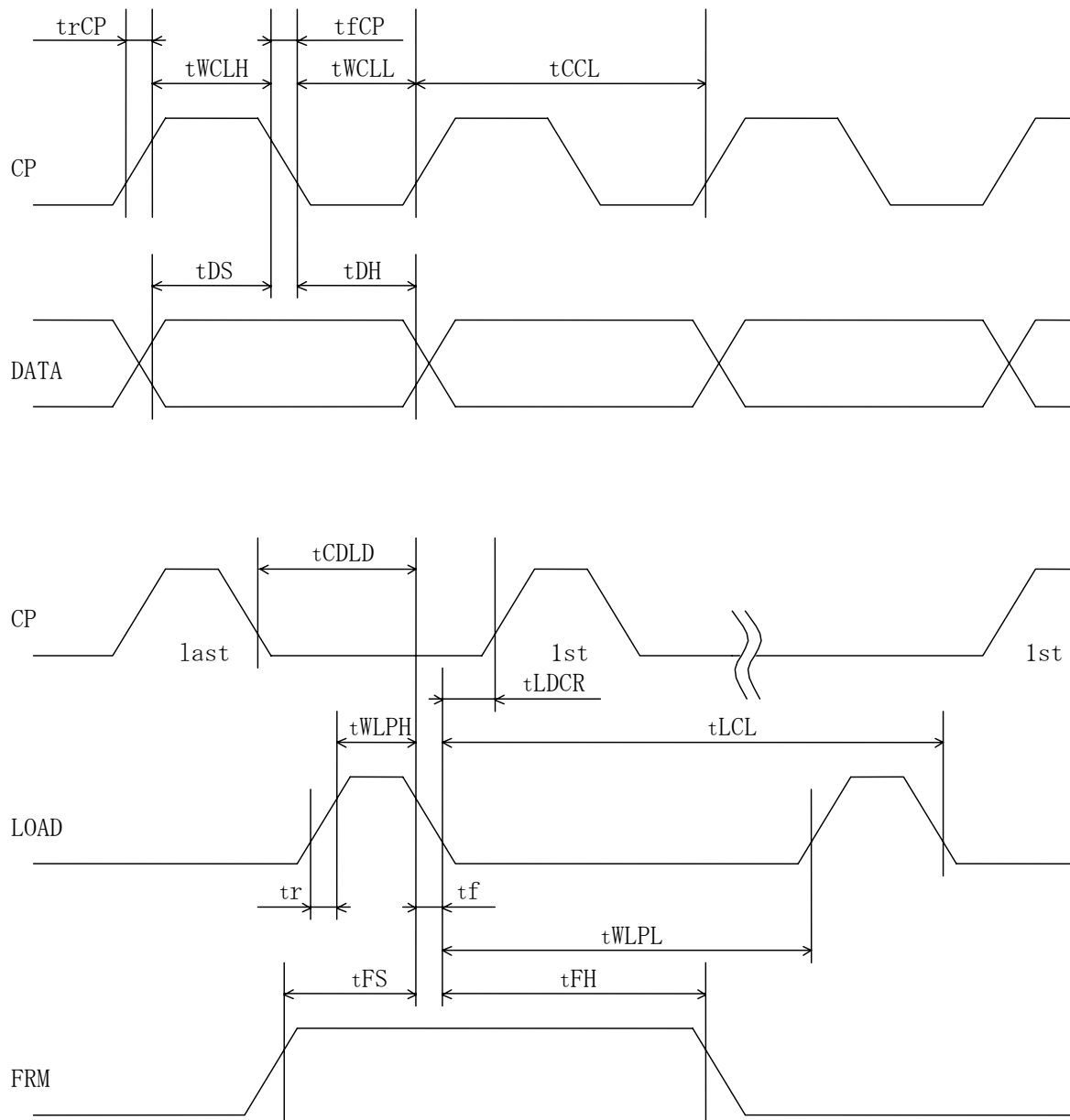

11-1. Switching characteristics ( $V_{DD} = 5.0V$ )

Input characteristics :  $V_{DD} = +5.0V \pm 5\%$ , Temp. =  $0 \sim 60^{\circ}C$

Item	Symbol	Min.	Max.	Unit
CP cycle *1	tCCL	100	-	ns
CP "H" pulse width	tWCLH	30	-	ns
CP "L" pulse width	tWCLL	30	-	ns
CP rise up time	trCP	-	15	ns
CP fall down time	tfCP	-	15	ns
Data set up time	tDS	25	-	ns
Data hold time	tDH	25	-	ns
LOAD "H" pulse width	tWLPH	40	-	ns
LOAD "L" pulse width	tWLPL	400	-	ns
LOAD cycle *2	tLCL	500	-	ns
CP → LOAD delay time	tCDLD	60	-	ns
LOAD → CP delay time	tLDCR	60	-	ns
Input signal rise up time	tr	-	20	ns
Input signal fall down time	tf	-	20	ns
FRM data set up time	tFS	120	-	ns
FRM data hold time	tFH	30	-	ns

\*1 CP cycle is adjusted so that FRM signal is 75Hz.

\*2 LOAD cycle is constant.

11-2. Switching characteristics ( $V_{DD} = 3.3V$ )

Input characteristics :  $V_{DD} = +3.3V \pm 0.3V$ , Temp. =  $0 \sim 60^{\circ}C$

Item	Symbol	Min.	Max.	Unit
CP cycle *1	tCCL	100	-	ns
CP "H" pulse width	tWCLH	40	-	ns
CP "L" pulse width	tWCLL	40	-	ns
CP rise up time	trCP	-	20	ns
CP fall down time	tfCP	-	20	ns
Data set up time	tDS	35	-	ns
Data hold time	tDH	35	-	ns
LOAD "H" pulse width	tWLPH	50	-	ns
LOAD "L" pulse width	tWLPL	400	-	ns
LOAD cycle *2	tLCL	500	-	ns
CP → LOAD delay time	tCDLD	60	-	ns
LOAD → CP delay time	tLDCR	80	-	ns
Input signal rise up time	tr	-	20	ns
Input signal fall down time	tf	-	20	ns
FRM data set up time	tFS	120	-	ns
FRM data hold time	tFH	30	-	ns

\*1 CP cycle is adjusted so that FRM signal is 75Hz.

\*2 LOAD cycle is constant.

## 12. Supply voltage sequence condition

In normal operation, logic within the LCD module reverses the polarity of the drive voltage every few lines to prevent DC damage to the liquid crystal material. But when a voltage is present on  $V_{CONT}$  outside of the time when the  $V_{DD}$  logic voltage is stable, a drive voltage is applied to the liquid crystal material without the polarity reversals. This sometimes result in a deterioration of display quality and a reduction in life time.

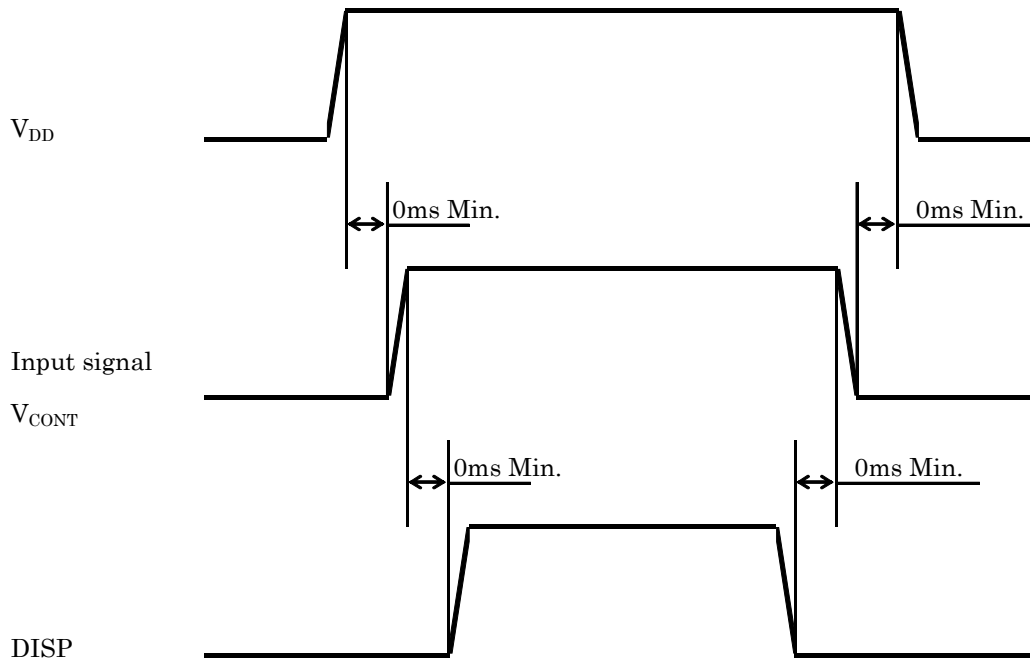

\* Input signal: FRM, LOAD, CP, D0~D7

\* The above sequence should be designed as to maintain each normal voltage when the liquid crystal module load is applied to your system.

\* Control the supply voltage sequence to not float any signal line when the LCD panel is being driven.

### 13. Backlight characteristics

#### CFL ratings

Item	Symbol	Min.	Typ.	Max.	Unit	Note
Starting discharge voltage *1	VS	-	-	1,550	Vrms	0°C
		-	-	1,035	Vrms	25°C
Discharge tube current *2	IL	3.0	4.0	6.0	mArms	-
Discharge tube voltage	VL	-	685	-	Vrms	-
Operating life time *3	T	60,000	75,000	-	h	IL=4.0mArms
Operating frequency	F	30	-	100	kHz	-

\*1 The non-load output voltage (VS) of the inverter should be at least 1.3 times the maximum VS at low temperatures to provide enough margins to assure that the CFL will start, because actual VS may increase due to leakage current from the CFL cables. (Reference value: 2,015 Vrms Min.)

\*2 We recommend that you should set the discharging tube current lower than the typical value to prevent the accumulated heat of the CFL tube from deteriorating the performance of the LCD.

\*3 Defined as when the luminance or quantity of light has decreased to 50% of the initial value. The average life of a CFL will decrease when the LCD is operating at lower temperatures.

\* Prolonged storage in darkness and/or at low temperature may slow the ignition and rise to full brightness of the CFL. Please use an inverter designed to provide sufficient starting voltage for more than 1 second. Also a decreased starting discharge voltage or shortened ignition time may not turn ON the CFL lamp.



## 14. Lot number identification

The lot number shall be indicated on the back of the backlight case of each LCD.

KCG057QV1DB-G500 - □□ - □ - □ MADE IN □□□□□□

↓ ↓   ↓ ↓   ↓  
 1 2   3 4   5

No1. - No5. above indicate

1. Year code
2. Month code
3. Date
4. Version Number
5. Country of origin (Japan or China)

Year	2007	2008	2009	2010	2011	2012
Code	7	8	9	0	1	2

Month	Jan.	Feb.	Mar.	Apr.	May	Jun.
Code	1	2	3	4	5	6

Month	Jul.	Aug.	Sep.	Oct.	Nov.	Dec.
Code	7	8	9	X	Y	Z

## 15. Warranty

### 15-1. Incoming inspection

Please inspect the LCD within one month after your receipt.

### 15-2. Production warranty

Kyocera warrants its LCD's for a period of 12 months from the ship date. Kyocera shall, by mutual agreement, replace or re-work defective LCD's that are shown to be Kyocera's responsibility.

## 16. Precautions for use

### 16-1. Installation of the LCD

- 1) The LCD module has a grounding hole. Please ground the module to prevent noise and to stabilize its performance as circumstances demand.
- 2) A transparent protection plate shall be added to protect the LCD and its polarizer.
- 3) The LCD shall be installed so that there is no pressure on the LSI chips.
- 4) The LCD shall be installed flat, without twisting or bending.
- 5) The display window size should be the same as the effective viewing area.
- 6) Please refer to the following our recommendable value of Clamp-down torque when installing.  
Clamp-down torque :  $0.32 \pm 0.03 \text{N} \cdot \text{m}$   
Please set up 'SPEED-LOW', 'SOFT START-SLOW' when using electric driver.  
Recommendable screw JIS tapping screw two types nominal dia.3.0mm installing boss hole depth  $3.5 \pm 0.5 \text{mm}$   
Please be careful not to use high torque which may damage LCD module in installation.
- 7) A transparent protection sheet is attached to the polarizer. Please remove the protection film slowly before use, paying attention to static electricity.

### 16-2. Static electricity

- 1) Since CMOS ICs are mounted directly onto the LCD glass, protection from static electricity is required.
- 2) Workers should use body grounding. Operator should wear ground straps.

### 16-3. LCD operation

- 1) The LCD shall be operated within the limits specified. Operation at values outside of these limits may shorten life, and/or harm display images.
- 2) Adjust the "Supply voltage for LCD driving ( $V_{\text{CONT}}$ )" to obtain optimum viewing angle and contrast ratio.

### 16-4. Storage

- 1) The LCD shall be stored within the temperature and humidity limits specified.  
Store in a dark area, and protect the LCD from direct sunlight or fluorescent light.
- 2) Always store the LCD so that it is free from external pressure onto it.

### 16-5. Usage

- 1) **DO NOT** store in a high humidity environment for extended periods. Polarizer degradation bubbles, and/or peeling off of the polarizer may result.
- 2) The front polarizer is easily scratched or damaged. Prevent touching it with any hard material, and from being pushed or rubbed.
- 3) The LCD screen may be cleaned by wiping the screen surface with a soft cloth or cotton pad using a little Ethanol.
- 4) Water may cause damage or discoloration of the polarizer. Clean condensation or moisture from any source immediately.
- 5) Always keep the LCD free from condensation during testing. Condensation may permanently spot or stain the polarizer.
- 6) Do not pull the CFL lead wires and do not bend the root of the wires. Housing should be designed to protect CFL lead wires from external stress.
- 7) Do not disassemble LCD module because it will result in damage.
- 8) This Kyocera LCD module has been specifically designed for use in general electronic devices, but not for use in a special environment such as usage in an active gas. Hence, when the LCD is supposed to be used in a special environment, evaluate the LCD thoroughly beforehand and do not expose the LCD to chemicals such as an active gas.
- 9) Please do not use solid-base image pattern for long hours because a temporary afterimage may appear. We recommend using screen saver etc. in cases where a solid-base image pattern must be used.
- 10) Liquid crystal may leak when the module is broken. Be careful not to let the fluid go into your eyes and mouth. In the case the fluid touches your body; rinse it off right away with water and soap.

## 17. Reliability test data

Test item	Test condition	Test time	Judgement
High temp. atmosphere	70°C	240h	Display function : No defect Display quality : No defect Current consumption : No defect
Low temp. atmosphere	-20°C	240h	Display function : No defect Display quality : No defect Current consumption : No defect
High temp. humidity atmosphere	40°C 90% RH	240h	Display function : No defect Display quality : No defect Current consumption : No defect
Temp. cycle	-20°C 0.5h R.T. 0.5h 70°C 0.5h	10cycles	Display function : No defect Display quality : No defect Current consumption : No defect
High temp. operation	60°C	500h	Display function : No defect Display quality : No defect Current consumption : No defect

\* Each test item uses a test LCD only once. The tested LCD is not used in any other tests.

\* The LCD is tested in circumstances in which there is no condensation.

\* The reliability test is not an out-going inspection.

\* The result of the reliability test is for your reference purpose only.

The reliability test is conducted only to examine the LCD's capability.

No	Description	Drawn	Checked	Checked	Approved
△	-Change Connector(LEAD FREE). -Add Matching Connector(LEAD FREE). -Change Scale Back side drawing.	'05.01.12 倉元	'05.01.12 川田原		'05.01.12 阿部
△	-Change the parts No. of Connector (Typographical error) (コネクタ-部品名称(誤記訂正)) -Add Japanese Comment (日本語追加)	'06.05.15 野崎	'06.05.20 茶園		'06.05.20 阿部

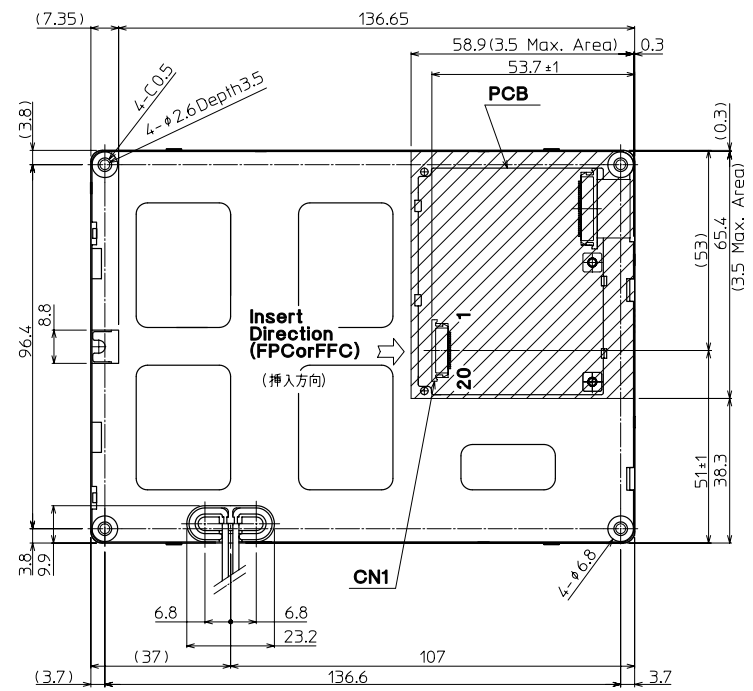
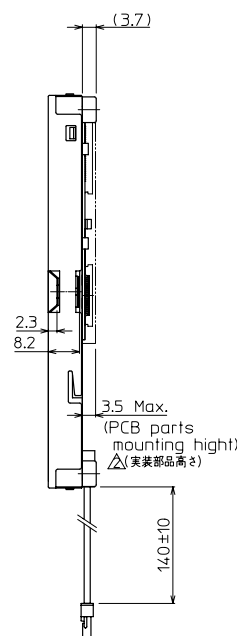
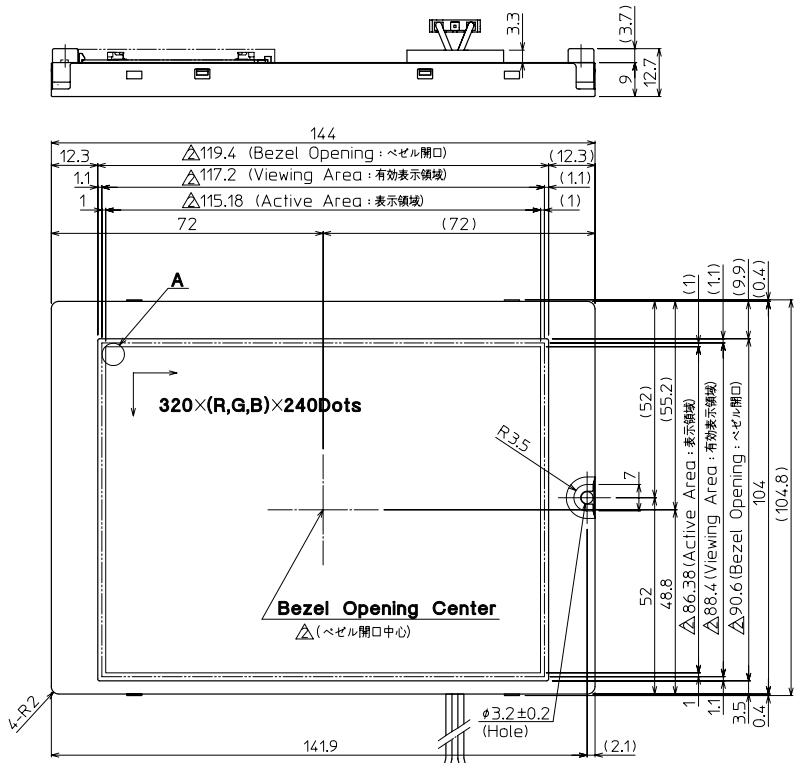

△ Back side drawing (1:2)

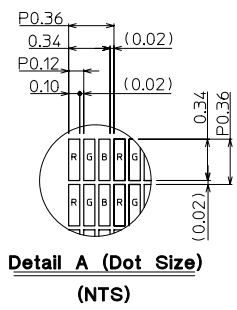

- (Note.) △08-6210-020-340-800+
- Connector CN1: 08-6210-020-340-800 (ELCO) (コネクタ) CN2: BHR-03VS-1 (JST)
  - Matching Connector CN2: △SM02(8.0)B-BHS-1 (JST) (適合コネクタ) △SM02(8.0)B-BHS-1-TB(LF)(SN) (JST) △SM02(8.0)B-BHS-1-TB (JST) △SM02(8.0)B-BHS-1-TB-(LF)(SN) (JST)
  - The drawing is the front view of the LCD. Information is displayed starting at the upper left hand corner, moving right then down to the lower right hand corner. (LCDの正面図において、画像データの表示は左上コーナーから始まり、右へ進み下へ送られ右下コーナーへ向かう。) (指示無き公差) ±0.5

Material 材質	Treatment 処理	Approved '02.07.26	Checked '02.07.26	Checked '02.07.26	Drawn 倉元	Scale 1:1 (NTS)	Title KCG057QV1DB	Year-Month-Day '02.07.26	Size 2
Quantity 製作数	Description: 備考	RoHS 05006AAA	阿部	今村			Outline Dimensions	Drawing No. 121A5018300-2	

Spec No.	TQ3C-8EAC0-E2DDV11-00
Date	February 20, 2007

**KYOCERA INSPECTION STANDARD**

**TYPE : KCG057QV1DB-G500**

KYOCERA CORPORATION  
KAGOSHIMA HAYATO PLANT  
LCD DIVISION

Original Issue Date	Designed by : Engineering dept.			Confirmed by : QA dept.	
	Prepared	Checked	Approved	Checked	Approved
February 20, 2007	<i>Y. Asano</i>	<i>H. Yamaguchi</i>	<i>Y. Matsumoto</i>	<i>J. Sakaguchi</i>	<i>H. Ishi</i>

Spec No. TQ3C-8EAC0-E2DDV11-00	Part No. KCG057QV1DB-G500	Page -
-----------------------------------	------------------------------	-----------

**Revision record**

Date		Designed by : Engineering dept.			Confirmed by : QA dept.	
		Prepared	Checked	Approved	Checked	Approved
Rev.No.	Date	Page	Descriptions			

## Visuals specification

### 1) Note

Item	Note	
General	<p>1. When defects specified in this Inspection Standards are inspected, operating voltage (V<sub>OP</sub>) shall be set at the level where optimized contrast is available. Display quality is applied up to effective viewing area. (Bi-level INSPECTION)</p> <p>2. This inspection standard about the image quality shall be applied to any defect within the effective viewing area and shall not be applicable to outside of the area.</p> <p>3. Should any defects which are not specified in this standard happen, additional standard shall be determined by mutual agreement between customer and Kyocera.</p> <p>4. Inspection conditions</p> <p style="margin-left: 40px;">Luminance : 500 Lux minimum.</p> <p style="margin-left: 40px;">Inspection distance : 300 mm (from the sample)</p> <p style="margin-left: 40px;">Temperature : 25±5°C</p> <p style="margin-left: 40px;">Direction : right above</p>	
Definition of inspection item	Pinhole, Bright spot Black spot, Scratch Foreign particle	The color of a small area is different from the remainder. The phenomenon does not change with voltage.
	Contrast variation	The color of a small area is different from the remainder. The phenomenon change with voltage.
	Polarizer (Scratch, Bubble, Dent)	Scratch, Bubble and Dent in the polarizer which can be observed in on / off state.

2)Standard

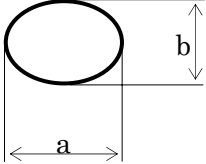
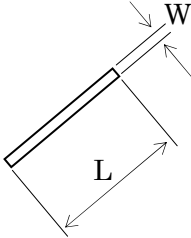
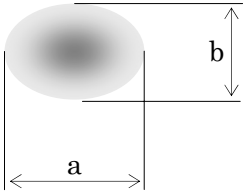
Inspection item	Judgement standard																						
Pinhole, Bright spot, Black spot, Foreign particle	 $d = (a + b) / 2$ <table border="1" data-bbox="608 573 1417 775"> <thead> <tr> <th>Category</th> <th>Size(mm)</th> <th>Acceptable number</th> </tr> </thead> <tbody> <tr> <td>A</td> <td><math>d \leq 0.2</math></td> <td>Neglected</td> </tr> <tr> <td>B</td> <td><math>0.2 &lt; d \leq 0.3</math></td> <td>5</td> </tr> <tr> <td>C</td> <td><math>0.3 &lt; d \leq 0.5</math></td> <td>3</td> </tr> <tr> <td>D</td> <td><math>0.5 &lt; d</math></td> <td>0</td> </tr> </tbody> </table>	Category	Size(mm)	Acceptable number	A	$d \leq 0.2$	Neglected	B	$0.2 < d \leq 0.3$	5	C	$0.3 < d \leq 0.5$	3	D	$0.5 < d$	0							
Category	Size(mm)	Acceptable number																					
A	$d \leq 0.2$	Neglected																					
B	$0.2 < d \leq 0.3$	5																					
C	$0.3 < d \leq 0.5$	3																					
D	$0.5 < d$	0																					
Scratch, Foreign particle	 <table border="1" data-bbox="608 1149 1417 1473"> <thead> <tr> <th></th> <th>Width (mm)</th> <th>Length (mm)</th> <th>Acceptable number</th> </tr> </thead> <tbody> <tr> <td>A</td> <td><math>W \leq 0.03</math></td> <td>-</td> <td>Neglected</td> </tr> <tr> <td>B</td> <td rowspan="3"><math>0.03 &lt; W \leq 0.10</math></td> <td><math>L \leq 2.0</math></td> <td>Neglected</td> </tr> <tr> <td>C</td> <td><math>2.0 &lt; L \leq 4.0</math></td> <td>3</td> </tr> <tr> <td>D</td> <td><math>4.0 &lt; L</math></td> <td>0</td> </tr> <tr> <td>E</td> <td><math>0.10 &lt; W</math></td> <td>-</td> <td>According to 'Circular'</td> </tr> </tbody> </table>		Width (mm)	Length (mm)	Acceptable number	A	$W \leq 0.03$	-	Neglected	B	$0.03 < W \leq 0.10$	$L \leq 2.0$	Neglected	C	$2.0 < L \leq 4.0$	3	D	$4.0 < L$	0	E	$0.10 < W$	-	According to 'Circular'
	Width (mm)	Length (mm)	Acceptable number																				
A	$W \leq 0.03$	-	Neglected																				
B	$0.03 < W \leq 0.10$	$L \leq 2.0$	Neglected																				
C		$2.0 < L \leq 4.0$	3																				
D		$4.0 < L$	0																				
E	$0.10 < W$	-	According to 'Circular'																				
Contrast variation	 $d = (a + b) / 2$ <table border="1" data-bbox="608 1785 1417 1951"> <thead> <tr> <th>Category</th> <th>Size (mm)</th> <th>Acceptable number</th> </tr> </thead> <tbody> <tr> <td>A</td> <td><math>d \leq 0.5</math></td> <td>Neglected</td> </tr> <tr> <td>B</td> <td><math>0.5 &lt; d \leq 0.7</math></td> <td>3</td> </tr> <tr> <td>C</td> <td><math>0.7 &lt; d</math></td> <td>0</td> </tr> </tbody> </table>	Category	Size (mm)	Acceptable number	A	$d \leq 0.5$	Neglected	B	$0.5 < d \leq 0.7$	3	C	$0.7 < d$	0										
Category	Size (mm)	Acceptable number																					
A	$d \leq 0.5$	Neglected																					
B	$0.5 < d \leq 0.7$	3																					
C	$0.7 < d$	0																					

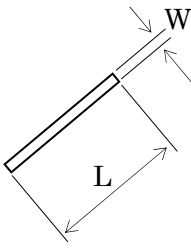
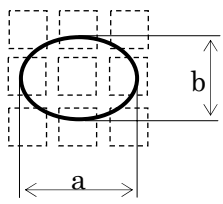

Inspection item	Judgement standard																			
Polarizer (Scratch, Bubble, Dent)	<p>(1) Scratch</p>  <table border="1" data-bbox="608 728 1418 1014"> <thead> <tr> <th></th> <th>Width (mm)</th> <th>Length (mm)</th> <th>Acceptable No.</th> </tr> </thead> <tbody> <tr> <td>A</td> <td><math>W \leq 0.1</math></td> <td>-</td> <td>Neglected</td> </tr> <tr> <td>B</td> <td rowspan="2"><math>0.1 &lt; W \leq 0.3</math></td> <td><math>L \leq 5.0</math></td> <td>Neglected</td> </tr> <tr> <td>C</td> <td><math>5.0 &lt; L</math></td> <td>0</td> </tr> <tr> <td>D</td> <td><math>0.3 &lt; W</math></td> <td>-</td> <td>0</td> </tr> </tbody> </table>		Width (mm)	Length (mm)	Acceptable No.	A	$W \leq 0.1$	-	Neglected	B	$0.1 < W \leq 0.3$	$L \leq 5.0$	Neglected	C	$5.0 < L$	0	D	$0.3 < W$	-	0
		Width (mm)	Length (mm)	Acceptable No.																
A	$W \leq 0.1$	-	Neglected																	
B	$0.1 < W \leq 0.3$	$L \leq 5.0$	Neglected																	
C		$5.0 < L$	0																	
D	$0.3 < W$	-	0																	
<p>(2) Bubble (dent)</p>  $d = (a + b) / 2$ <table border="1" data-bbox="608 1574 1418 1845"> <thead> <tr> <th>Category</th> <th>Size (mm)</th> <th>Acceptable number</th> </tr> </thead> <tbody> <tr> <td>A</td> <td><math>d \leq 0.2</math></td> <td>Neglected</td> </tr> <tr> <td>B</td> <td><math>0.2 &lt; d \leq 0.3</math></td> <td>5</td> </tr> <tr> <td>C</td> <td><math>0.3 &lt; d \leq 0.5</math></td> <td>3</td> </tr> <tr> <td>D</td> <td><math>0.5 &lt; d</math></td> <td>0</td> </tr> </tbody> </table>	Category	Size (mm)	Acceptable number	A	$d \leq 0.2$	Neglected	B	$0.2 < d \leq 0.3$	5	C	$0.3 < d \leq 0.5$	3	D	$0.5 < d$	0					
Category	Size (mm)	Acceptable number																		
A	$d \leq 0.2$	Neglected																		
B	$0.2 < d \leq 0.3$	5																		
C	$0.3 < d \leq 0.5$	3																		
D	$0.5 < d$	0																		