

SPEC. NO.	TQ3C-8EAC0-E1CUP64-00
DATE	January 31, 2006

S P E C

FOR : _____

TYPE : KCG057QV1DB-G77

CONTENTS

1. Application
2. Construction and Outline
3. Mechanical Specifications
4. Absolute Maximum Ratings
5. Electrical Characteristics
6. Optical Characteristics
7. Circuit Block Diagram
8. Interface Signals
9. Interface Timing Chart
10. Data and Screen
11. Input Timing Characteristics
12. Supply Voltage Sequence Condition
13. Backlight Characteristics
14. Lot Number Identification
15. Warranty
16. Precautions for Use
17. Reliability Data / Environmental Test
18. Outline Drawing

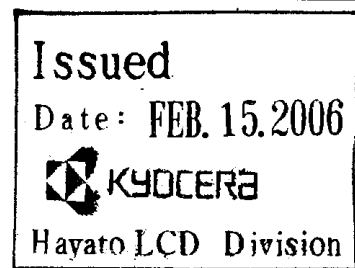

KYOCERA CORPORATION
KAGOSHIMA HAYATO PLANT
LCD DIVISION

This specification is subject to change without notice.
Consult Kyocera before ordering.

Original	Designed by :Engineering Dept.			Confirmed by :QA Dept.		
	Issue Date	Prepared	Checked	Approved	Checked	Approved
January 31, 2006	<i>H. Nishino</i>	<i>Y. Yamaguchi</i>	<i>M. Fujitani</i>	<i>Y. Matsumoto</i>	<i>S. Hayashi</i>	

Caution

1. This Kyocera LCD module has been specifically designed for use only in electronic devices in the areas of audio control, office automation, industrial control, home appliances, etc. The modules should not be used in applications where module failure could result in physical harm or loss of life, and Kyocera expressly disclaims any and all liability relating in any way to the use of the module in such applications.
2. Customer agrees to indemnify, defend and hold Kyocera harmless from and against any and all actions, claims, losses, damages, liabilities, awards, costs, and expenses, including legal fees, resulting from or arising out of Customer's use, or sale for use, of Kyocera modules in applications.
3. Kyocera shall have the right, which Customer hereby acknowledges, to immediately scrap or destroy tooling for Kyocera modules for which no Purchase Orders have been received from the Customer in a two-year period.

Revision Record

Date	Designed by: Engineering Dept.			Confirmed by: QA Dept.	
	Prepared	Checked	Approved	Checked	Approved
Rev. No.	Date	Page	Descriptions		

1. Application

This data sheet defines the specification for a $(320 \times R.G.B) \times 240$ dot, STN Transmissive color dot matrix type Liquid Crystal Display with CFL backlight.

『RoHS Compliance』

2. Construction and Outline

$(320 \times R.G.B) \times 240$ dots, COG type LCD with CFL backlight.

Backlight system : "U" figured type CFL (1 tube).

Inverter : Option.
Recommended Inverter : CXA-L0612A-VJL(TDK)
or Equivalent.

Polarizer : Glare treatment.

Additional circuit : Bias voltage circuit, Randomizing circuit, DC-DC Converter

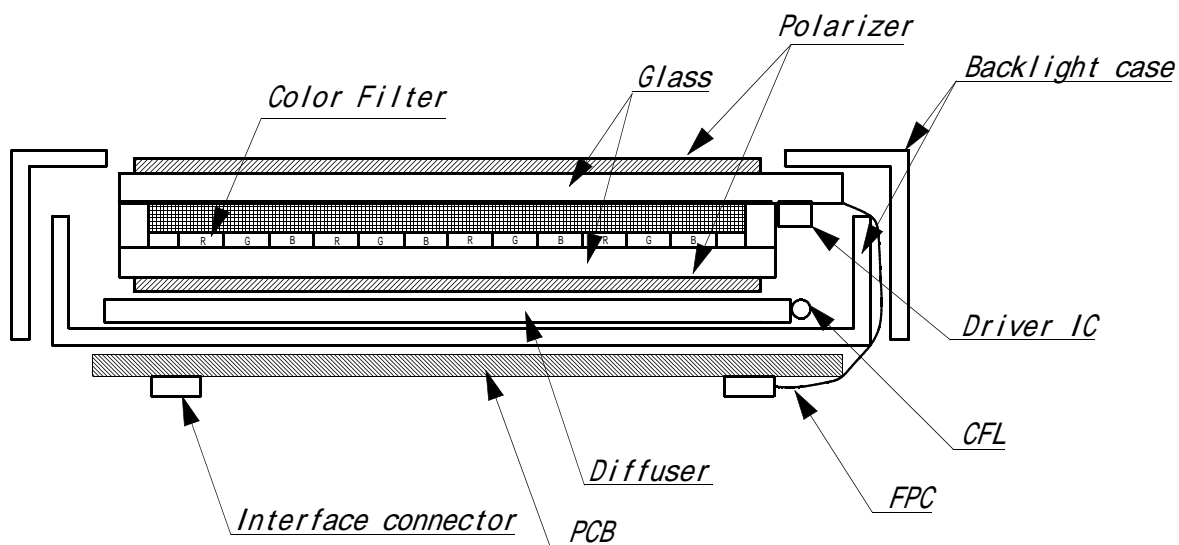

This drawing is showing conception only.

3. Mechanical Specifications

ITEM	SPECIFICATION	UNIT
Outline dimensions	144.0 (W) × 104.8 (H) × 12.7 (D)	mm
Effective viewing area	117.2 (W) × 88.4 (H)	mm
Dot number	(320 × R.G.B) (W) × 240 (H)	Dots
Dot size	0.10 (W) × 0.34 (H)	mm
Dot pitch	0.12 (W) × 0.36 (H)	mm
Display color *1	White *2	-
Base color *1	Black *2	-
Mass	175	g

*1 Due to the characteristics of the LC material, the color vary with environmental temperature.

*2 Negative-type display

Display data "H" :R.G.B Dots ON : White

Display data "L" :R.G.B Dots OFF : Black

4. Absolute Maximum Ratings

4-1. Electrical absolute maximum ratings

ITEM	SYMBOL	MIN.	MAX.	UNIT
Supply voltage for logic	VDD	0	6.0	V
Supply voltage for LCD driving	VCONT	0	VDD	V
Input signal voltage *1	Vin	0	VDD	V
FRM frequency	fFRM	-	150	Hz

*1 Input signal : CP, LOAD, FRM, DISP, D0 ~ D7

4-2. Environmental absolute maximum ratings

ITEM	SYMBOL	MIN	MAX	UNIT
Operating temperature *1	Top	0	60	
Storage temperature *2	T _{STO}	-20	60	
Operating humidity *3	Hop	10	*4	%RH
Storage humidity *3	H _{STO}	10	*4	%RH
Vibration	-	*5	*5	-
Shock	-	*6	*6	-

*1 LCD's display quality shall not be guaranteed at the temperature range of :
below 0 and upper 40 .

*2 Temp. = -20 < 48 h , Temp = 60 < 168 h
Store LCD panel at normal temperature/humidity.
Keep it free from vibration and shock.
LCD panel that is kept at low or high temperature for a long time can be defective due to
the other conditions, even if the temperature satisfies standard.
(Please refers to 16. Precautions for use as detail).

*3 Non-condensation.

*4 Temp. 40 , 85% RH Max.
Temp. > 40 , Absolute Humidity shall be less than 85%RH at 40 .

*5

Frequency	10 ~ 55 Hz	Converted to acceleration value : (0.3 ~ 9 m/s ²)
Vibration width	0.15 mm	
Interval	10-55-10 Hz 1 minute	

2 hours in each direction X/Y/Z (6 hours as total)
EIAJ ED-2531

*6 Acceleration: 490m/s²
Pulse width : 11 ms
3 times in each direction : ±X/ ±Y/ ±Z.
EIAJ ED-2531

5. Electrical Characteristics

5-1. VDD = 5.0V

VDD = +5.0V ± 5%, Temp. = 0 ~ 60

ITEM	SYMBOL	CONDITION	MIN.	TYP.	MAX.	UNIT
Supply voltage for logic	VDD	-	4.75	5.00	5.25	V
LCD driving voltage *1	Vop= VCONT	0 ~ 60	1.3	1.8	2.3	V
Input voltage (FRM, LOAD, CP, DISP, D0 ~ D7)	Vin	"H" level	0.8VDD	-	VDD	V
		"L" level	0	-	0.2VDD	V
Input current	Iin	Input signal	-100	-	100	μA
Rush current for logic	Irush	When rush current happens	3.0A(Peak) × 1ms			
Clock frequency	fcp	-	2.02	2.16	10.00	MHz
Frame frequency *2	fFRM	-	70	75	150	Hz
Current consumption for logic	IDD	*3	-	19.0	28.5	mA
Power consumption	Pdisp		-	95.0	142.5	mW

*1 Maximum contrast ratio is obtained by adjusting the LCD supply voltage (Vop= VCONT) for driving LCD.

*2 In consideration of display quality, it is recommended that frame frequency is set in the range of 70-80Hz. When you have to use higher frame and clock frequencies, confirm the LCD's performance and quality prior to finalizing the frequency values:
Generally, as frame and clock frequencies become higher current consumption will get bigger and display quality will be degraded.

*3 Display high frequency pattern, (see below).
VDD = 5.0V , Vop = VCONT , fFRM = 75 Hz , fcp = 2.16MHz, Temp. = 25
Pattern:

```

1 2 3 4 5 6 ----- 960(dot)
1
2
3
:
:
239
240
(dot)

```

5-2. VDD = 3.3V

VDD = +3.3V ± 0.3V, Temp. = 0 ~ 60

ITEM	SYMBOL	CONDITION	MIN.	TYP.	MAX.	UNIT
Supply voltage for logic	VDD	-	3.0	3.3	3.6	V
LCD driving voltage *1	Vop= VCONT	0 ~ 60	1.3	1.8	2.3	V
Input voltage (FRM, LOAD, CP, DISP, D0 ~ D7)	Vin	"H" level	0.8VDD	-	VDD	V
		"L" level	0	-	0.2VDD	V
Input current	Iin	Input signal	-100	-	100	μA
Rush current for logic	Irush	When rush current happens	3.0A(Peak) × 1ms			
Clock frequency	f _{cp}	-	2.02	2.16	10.00	MHz
Frame frequency *2	f _{FRM}	-	70	75	150	Hz
Current consumption for logic	IDD	*3	-	29.0	43.5	mA
Power consumption	Pdisp		-	95.7	143.6	mW

*1 Maximum contrast ratio is obtained by adjusting the LCD supply voltage (Vop= VCONT) for driving LCD.

*2 In consideration of display quality, it is recommended that frame frequency is set in the range of 70-80Hz. When you have to use higher frame and clock frequencies, confirm the LCD's performance and quality prior to finalizing the frequency values:
Generally, as frame and clock frequencies become higher current consumption will get bigger and display quality will be degraded.

*3 Display high frequency pattern, (see below).
VDD = 3.3V , Vop = VCONT , f_{FRM} = 75 Hz , f_{cp} = 2.16MHz, Temp. = 25
Pattern:

```

1 2 3 4 5 6 ----- 960(dot)
1
2
3
:
:
239
240
(dot)

```

6 . Optical Characteristics

Temp. = 25

ITEM		SYMBOL	CONDITION	MIN.	TYP.	MAX.	UNIT	
Response time	Rise	Tr	= =0 °	-	250	360	ms	
	Down	Td	= =0 °	-	200	290	ms	
Viewing angle range			CR 2	Upper	-	65	-	deg.
				Lower	-	70	-	
				Left	-	55	-	deg.
				Right	-	55	-	
Contrast ratio		CR	= =0 °	30	60	-	-	
Brightness		L	IL=4.0mA	250	380	-	cd/m ²	
Chromaticity coordinates	Red	x	= =0 °	0.57	0.62	0.67	-	
		y		0.29	0.34	0.39		
	Green	x	= =0 °	0.23	0.28	0.33		
		y		0.50	0.55	0.60		
	Blue	x	= =0 °	0.09	0.14	0.19		
		y		0.05	0.10	0.15		
	White	x	= =0 °	0.25	0.30	0.35		
		y		0.26	0.31	0.36		

Optimum contrast is obtained by adjusting the LCD driving voltage(Vop) while at the viewing angle of = =0 ° .

6-1. Contrast ratio is defined as follows:

$$CR = \frac{\text{Brightness at all pixels "White"}}{\text{Brightness at all pixels "Black"}}$$

6-2. Definition of Vop

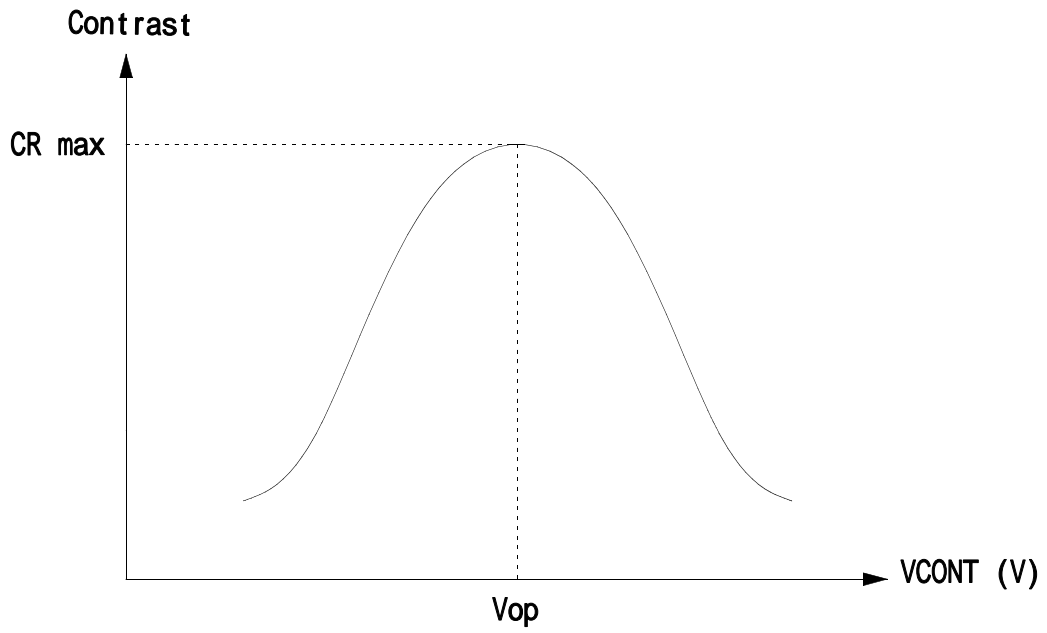

6-3. Definition of response time

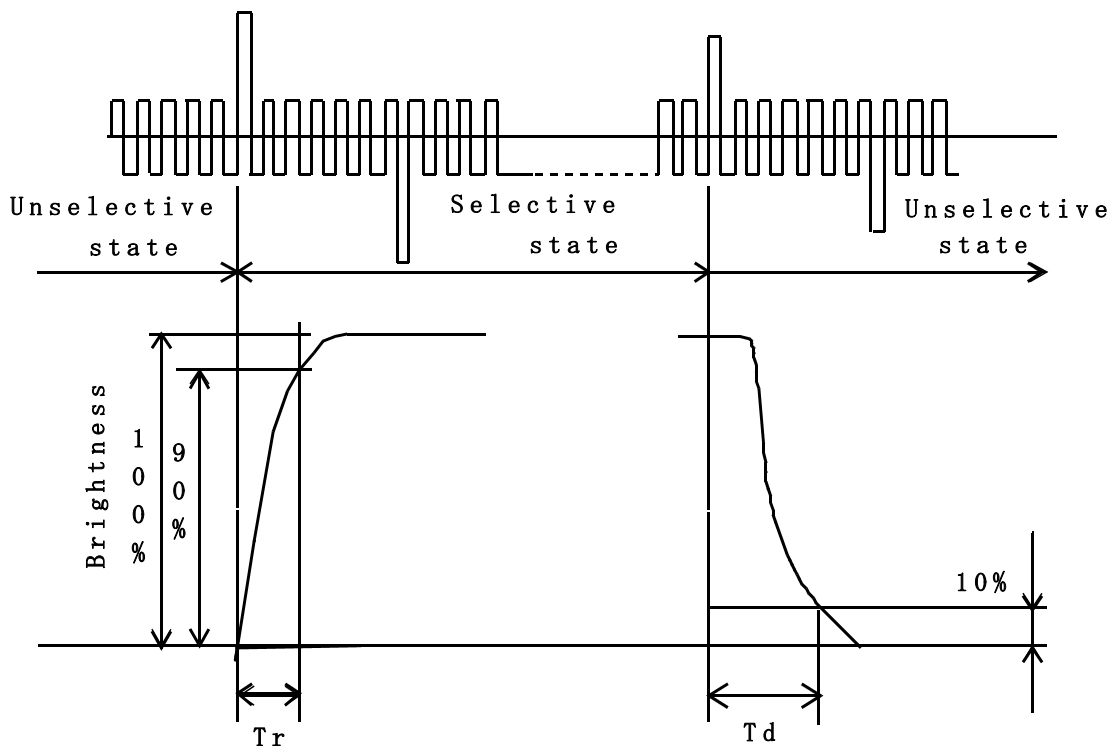

6-4. Definition of viewing angle

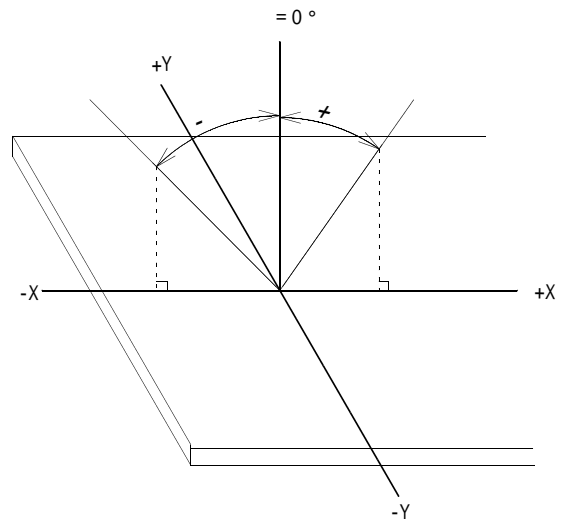
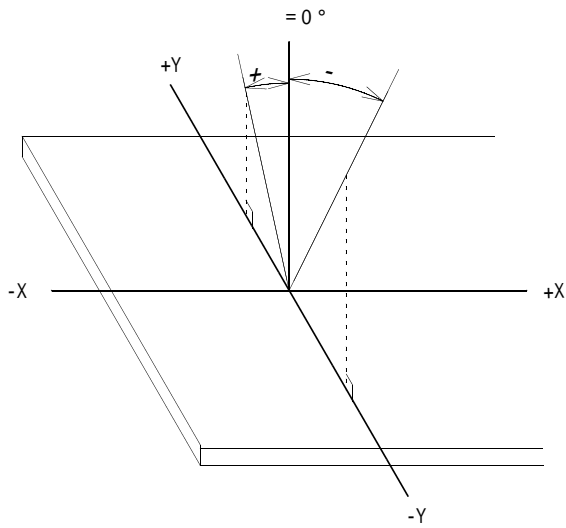

6-5. Measuring points

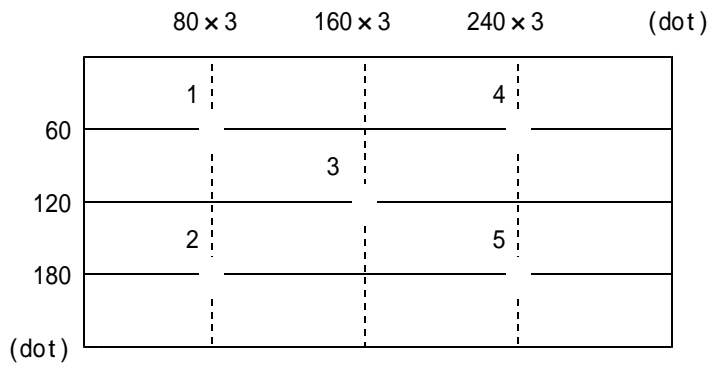

- 1) Rating is defined as the average brightness inside the viewing area.
- 2) 30 minutes after CFL is turned on. (Ambient Temp.= 25)
- 3) The inverter should meet the eccentric conditions;
 - Sine, symmetric waveform without spike in positive and negative.

7. Circuit Block Diagram

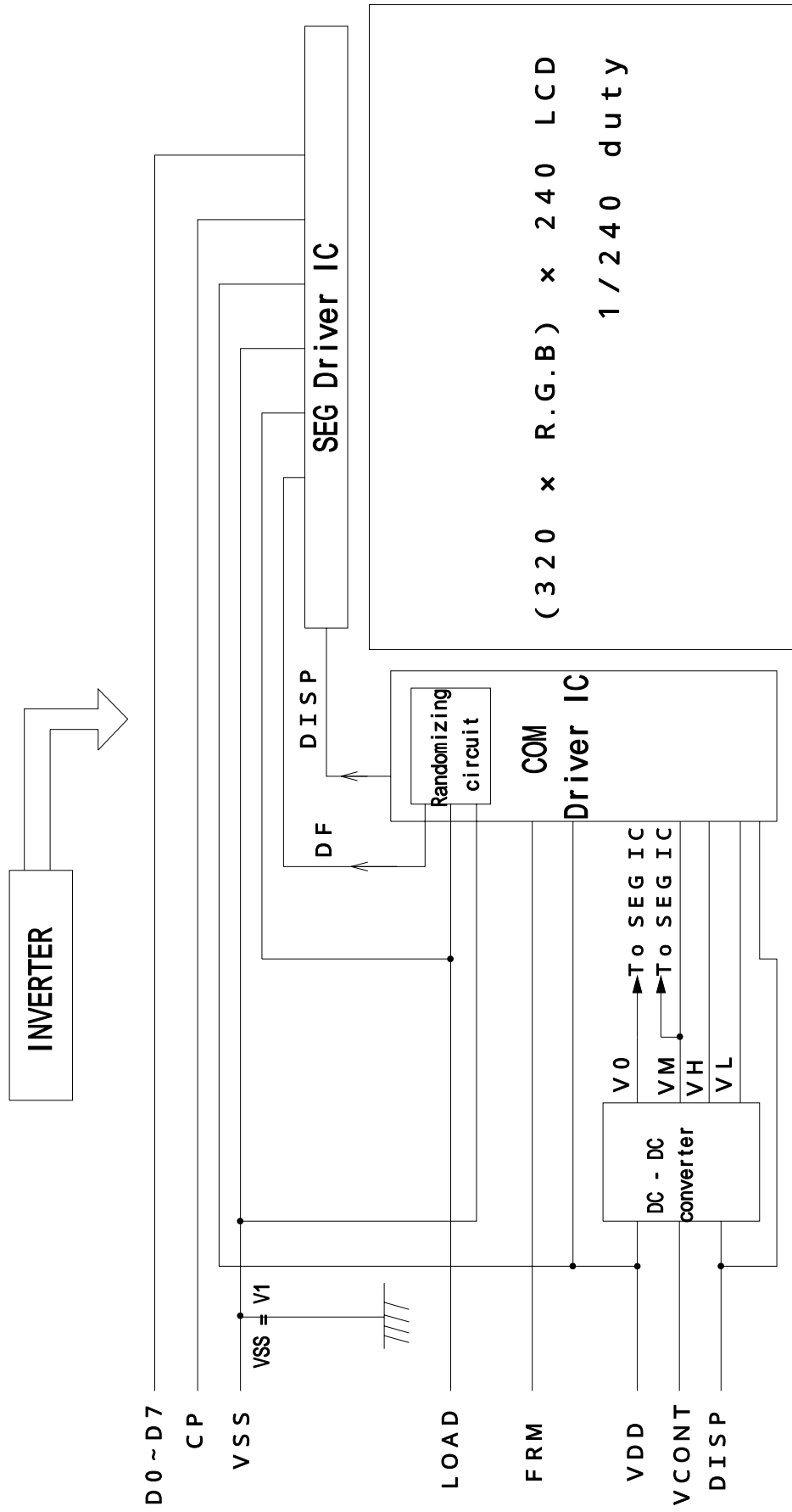

7-1. Power supply

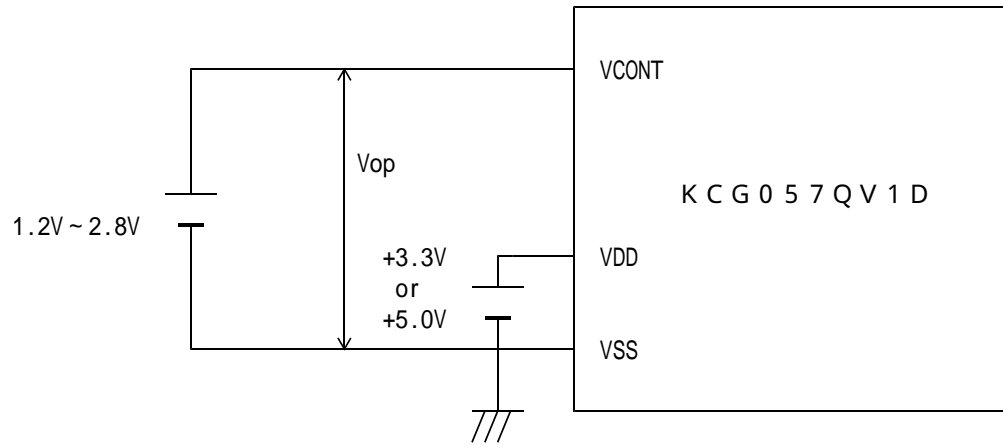

8. Interface signals

8-1. LCD

PIN	SYMBOL	DESCRIPTION	LEVEL
1	FRM	Synchronous signal for driving scanning line	H
2	LOAD	Data signal latch clock	H L
3	CP	Data signal shift clock	H L
4	DISP	Display control signal	H(ON),L(OFF)
5	VDD	Power supply for logic	
6	VSS	GND	
7	VCONT	LCD adjust voltage	
8	D7	Display data	H(ON),L(OFF)
9	D6		
10	D5		
11	D4		
12	D3		
13	D2		
14	D1		
15	D0		
16	VDD	Power supply for logic	-
17	VDD		
18	VSS	GND	-
19	VSS		
20	VSS		
20	VSS		

LCD connector : 08-6210-020-340-800+ (ELCO)

Recommended matching connector : 0.5mm pitch FFC or FPC

8-2. CFL

PIN No	SYMBOL	DESCRIPTION
1	HOT	Inverter output high voltage side
2	NC	
3	COLD	Inverter output low voltage side

LCD side connector : BHR-03VS-1 (JST)

Recommended matching connector : SM02-(8.0)B-BHS-1 (JST)

: SM02-(8.0)B-BHS-1-TB-(LF)(SN) (JST).....(RoHS)

9 . Interface Timing Chart

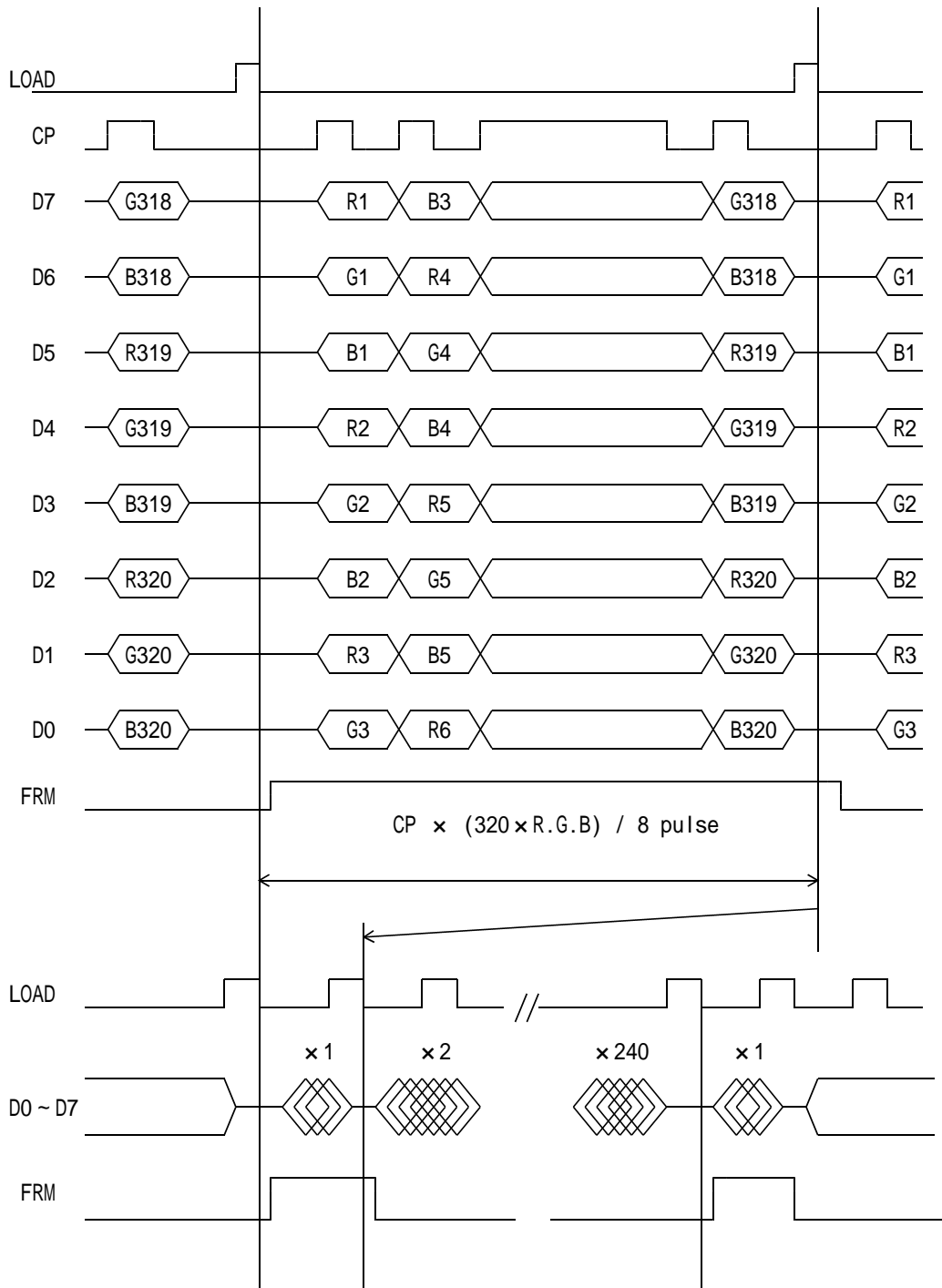

* The cycle of load signal should be stable and continuously applied without interruption.

* The above-mentioned timing chart shows a reference to set up a LCD module, not an electrical rating.

1 0 . Data and Screen

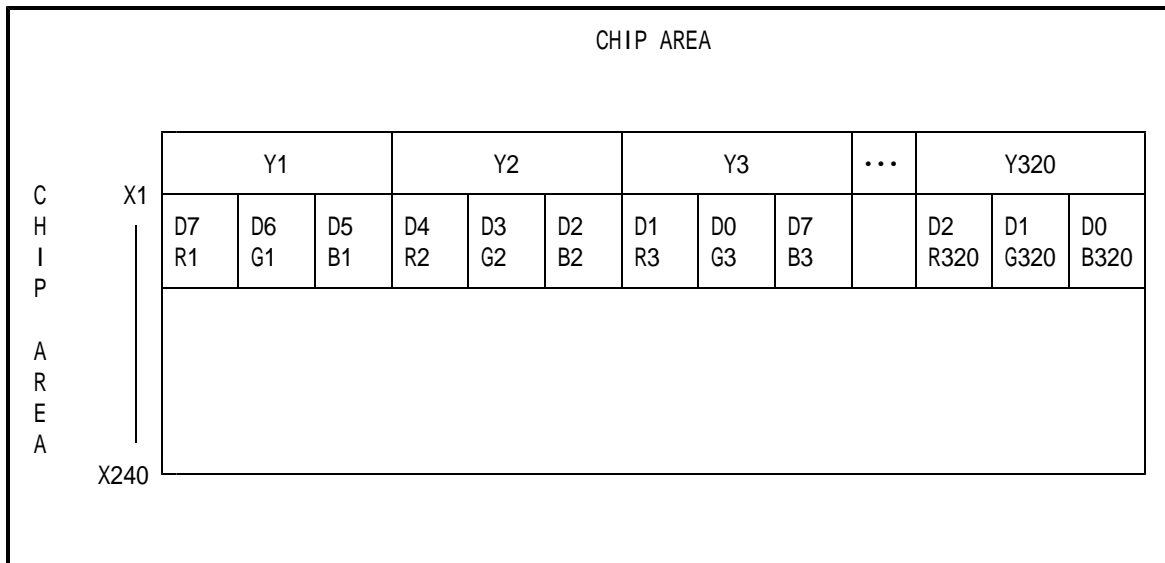

1 1 . Input Timing Characteristics

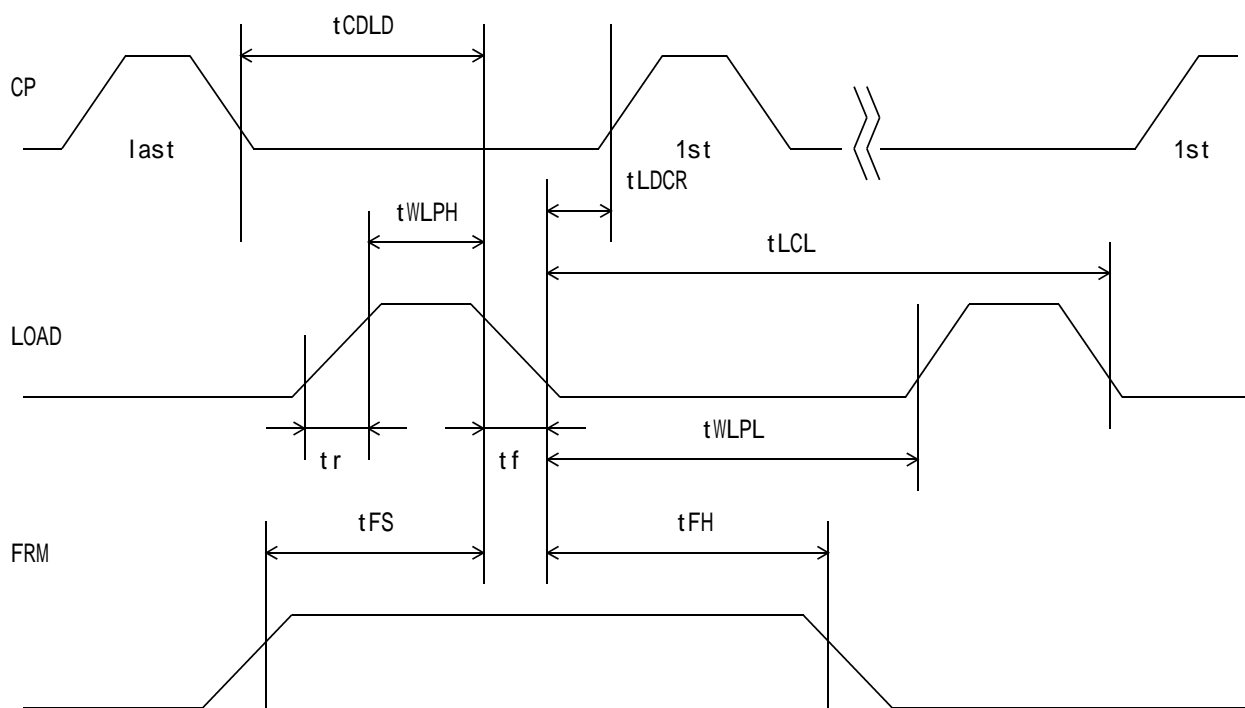
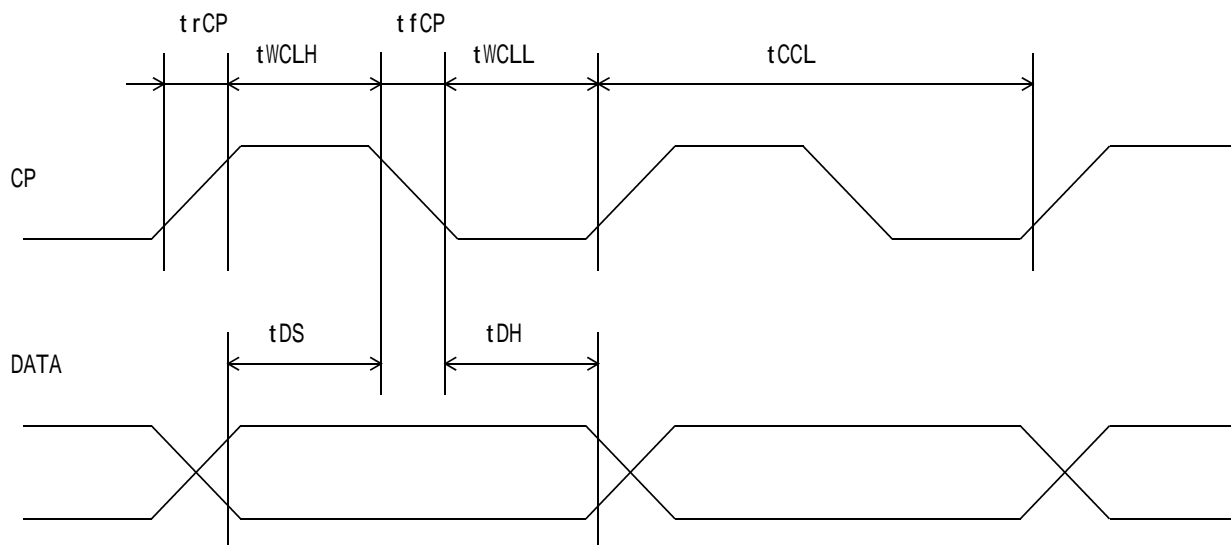

11-1. Switching characteristics (VDD = 5.0V)

Input Characteristics ; VDD = +5.0V \pm 5%, Temp. = 0~60

ITEM	SYMBOL	MIN.	MAX.	UNIT
CP Cycle *1	tCCL	100	-	ns
CP "H" Pulse Width	tWCLH	30	-	ns
CP "L" Pulse Width	tWCLL	30	-	ns
CP Rise Up Time	trCP	-	15	ns
CP Fall Down Time	tfCP	-	15	ns
Data Set Up Time	tDS	25	-	ns
Data Hold Time	tDH	25	-	ns
LOAD "H" Pulse Width	tWLPH	40	-	ns
LOAD "L" Pulse Width	tWLPL	400	-	ns
LOAD Cycle *2	tLCL	500	-	ns
CP Down LOAD Down Delay Time	tCDLD	60	-	ns
LOAD Down CP Rise Delay Time	tLDCR	60	-	ns
Input Signal Rise Up Time	tr	-	20	ns
Input Signal Fall Down Time	tf	-	20	ns
FRM Data Set Up Time	tFS	120	-	ns
FRM Data Hold Time	tfH	30	-	ns

*1 CP Cycle is adjust so that FRM signal is 75Hz.

*2 LOAD Cycle is const.

11-2. Switching characteristics (VDD = 3.3V)

Input Characteristics ; VDD = +3.3V ± 0.3V, Temp. = 0~60

ITEM	SYMBOL	MIN.	MAX.	UNIT
CP Cycle *1	tCCL	100	-	ns
CP "H" Pulse Width	tWCLH	40	-	ns
CP "L" Pulse Width	tWCLL	40	-	ns
CP Rise Up Time	trCP	-	20	ns
CP Fall Down Time	tfCP	-	20	ns
Data Set Up Time	tDS	35	-	ns
Data Hold Time	tDH	35	-	ns
LOAD "H" Pulse Width	tWLPH	50	-	ns
LOAD "L" Pulse Width	tWLPL	400	-	ns
LOAD Cycle *2	tLCL	500	-	ns
CP Down LOAD Down Delay Time	tCDLD	60	-	ns
LOAD Down CP Rise Delay Time	tLDCR	80	-	ns
Input Signal Rise Up Time	tr	-	20	ns
Input Signal Fall Down Time	tf	-	20	ns
FRM Data Set Up Time	tFS	120	-	ns
FRM Data Hold Time	tfH	30	-	ns

*1 CP Cycle is adjust so that FRM signal is 75Hz.

*2 LOAD Cycle is const.

1 2 . Supply Voltage Sequence Condition

DO NOT apply DC voltage to the LCD panel. DC voltage induce irreversible electrochemical reactions and reduce LCD life. Always follow the power supply ON/OFF sequence of VDD first, input signal second, VCONT third and finally DISP. This will prevent DC driving of the LCD or CMOS LSI latch up as shown below.

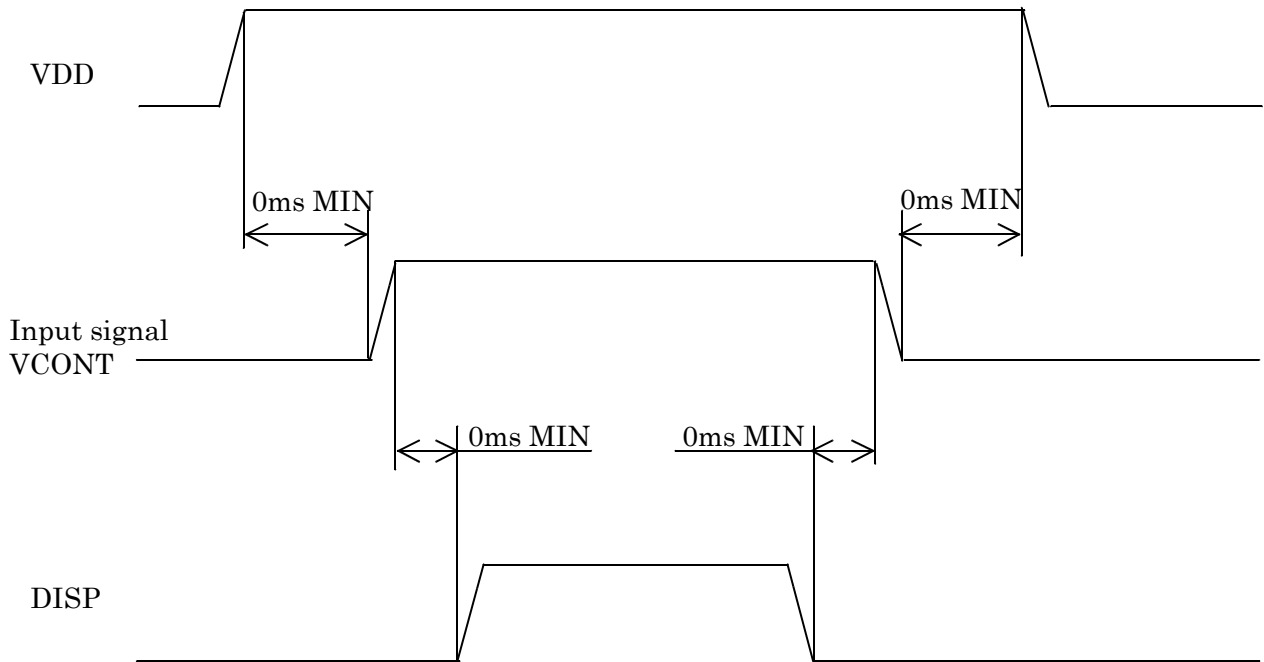

* Input signal : CP,LOAD,FRM,VCONT,D0 ~ D7

* The above sequence should be designed as to keep each normal figure on condition that liquid crystal module is loaded on your system.

* Control the input signal and VCONT to the above ON - OFF timing when you switch ON/OFF the display during VDD and DISP are on.
And design the circuit as VCONT's OFF level become GND level at the same time.

* Control the supply voltage sequence not to float all signal line when the LCD panel is driving.

1 3 . Backlight Characteristics

Temp. = 25

ITEM	SYMBOL	MIN.	TYP.	MAX.	NOTE
Starting discharge Voltage *1	VS	-	-	1,550 Vrms.	0
		-	-	1,035 Vrms.	25
Discharging tube current *2, *3	IL	3.0 mArms.	4.0 mArms.	6.0 mArms.	-
Discharging tube voltage	VL	-	685 Vrms.	-	-
Operating life (IL=4.0 mArms.) *4	T	60,000 h	75,000 h	-	-
Operating frequency	F	30 kHz	-	100 kHz	-

- *1 The Non-load output voltage (VS) of the inverter should be designed to have some margin, because VS may increase due to the leak current which may be caused by wiring of CFL cables. (Reference value: 2,015 Vrms MIN.)
- *2 We recommend that you should set the discharging tube current at lower than typical value so as to prevent the heat accumulation of CFL tube from deteriorating a performance of the LCD.
- *3 Do not apply more than 6.0mA discharging tube current. Because CFL maybe broken due to over current.
- *4 When the illuminance or quantity of light has decreased to 50 % of the initial value. Average life time of CFL will be decreased when LCD is operating at lower and higher temperature.
- * CFL arrangement figure

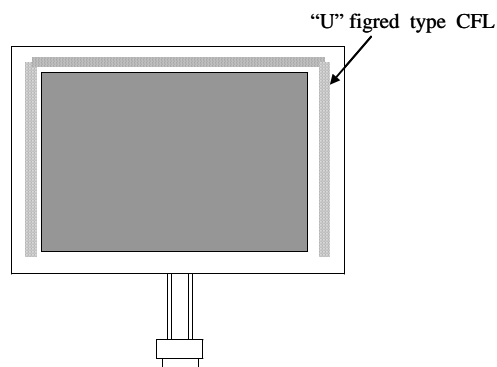

1 4 . Lot Number Identification

The lot number shall be indicated on the back of the backlight case of each LCD.

K C G 0 5 7 Q V 1 D B - G 7 7 - _____ - M A D E I N _____

YEAR
MONTH
DATE
Version Number
Country of origin (JAPAN or CHINA)

YEAR	2006	2007	2008	2009	2010	2011
CODE	6	7	8	9	0	1

MONTH	JAN.	FEB.	MAR.	APR.	MAY.	JUN.
CODE	1	2	3	4	5	6

MONTH	JUL.	AUG.	SEP.	OCT.	NOV.	DEC.
CODE	7	8	9	X	Y	Z

1 5 . Warranty

15-1. Incoming inspection

Please inspect the LCD within one month after your receipt.

15-2. Production Warranty

Kyocera warrants its LCDs for a period of 12 months after receipt by the purchaser, and within the limits specified. Kyocera shall, by mutual agreement, replace or rework defective LCDs that are shown to be Kyocera's responsibility.

16 . Precautions for use

16-1. Installation of the LCD

1. Please ground the mounting (screw) holes of an LCD module, in order to stabilize brightness and display quality.
2. A transparent protection plate shall be added to protect the LCD and its polarizers.
3. The LCD shall be installed so that there is no pressure on the LSI chips.
4. The LCD shall be installed flat, without twisting or bending.
5. The display window size should be the same as the effective viewing area.
6. In case you use outside frame of effective viewing area as outward appearance of your product, unevenness of its outward appearance is out of guarantee.
7. Do not pull the CFL lead wires and do not bend the root of the wires.
Housing should be designed to protect CFL lead wires from external stress.
8. A transparent protection sheet is attached to the polarizer. Please remove the protection film slowly before use, paying attention to static electricity.
9. This Kyocera LCD module has been specifically designed for use in general electronic devices, but not for use in a special environment such as usage in an active gas.
Hence, when the LCD is supposed to be used in a special environment, evaluate the LCD thoroughly beforehand and do not expose the LCD to chemicals such as an active gas.

16-2. Static Electricity

1. Since CMOS ICs are mounted directly onto the LCD glass, protection from static electricity is required. Operation should wear ground straps.

16-3. LCD Operation

1. The LCD shall be operated within the limits specified. Operation at values outside of these limits may shorten life, and/or harm display images.
2. Vop must be adjusted to optimize viewing angle and contrast.
3. Operation of the LCD at temperature below the limit specified may cause image degradation and/or bubbles.
It may also change the characteristics of the liquid crystal.
This phenomenon may not recover. The LCD shall be operated within the temperature limits specified.

16-4. Storage

1. The LCD shall be stored within the temperature and humidity limits specified.
Store in a dark area, and protected the LCD from direct sunlight or fluorescent light.
2. The LCD should be packaged to prevent damage.

16-5. Screen Surface

1. DO NOT store in a high humidity environment for extended periods.
Image degradation, bubbles, and/or peeling off of polarizer may result.
2. The front polarizer is easily scratched or damaged.
Prevent touching it with any hard material, and from being pushed or rubbed.
3. The LCD screen may be cleaned with a soft cloth or cotton pad.
Methanol, or Isopropyl Alcohol may be used, but insure that all solvent residue is removed.
4. Water may cause damage or discoloration of the polarizer.
Clean any condensation or moisture from any source immediately.
5. Always keep the LCD free from condensation during testing.
Condensation may permanently spot or stain the polarizers.
6. Please do not use solid-base image pattern for long hours because a temporary afterimage may appear. We recommend to use screen saver etc. in cases where a solid-base image pattern must be used.
7. Liquid crystal may leak when the module is broken. Be careful not to let the fluid go into your eyes and mouth. In the case the fluid touches your body, rinse it off right away with water and soap.

1 7 . Reliability Data / Environmental Test

TEST ITEM	TEST CONDITION	TEST TIME	RESULT
High Temp. Atmosphere	70	240 h	Display Quality : No defect Display Function : No defect Current Consumption : No defect
Low Temp. Atmosphere	-20	240 h	Low Temp. Bubble : None Solid Crystallization of Liquid Crystal : None Display Quality : No defect Display Function : No defect Current Consumption : No defect
High Temp. Humidity Atmosphere	40 90%RH	240 h	Display Quality : No defect Display Function : No defect Peel-off of Organic Sealing : None Current Consumption : No defect
Temp. Cycle	-20 0.5 h R.T. 0.5 h 70 0.5 h	10 cycles	Display Quality : No defect Display Function : No defect Peel-off of Organic Sealing : None Bubble on Cell : None
High Temp. Operation	60 Vop	500 h	Display Quality : No defect Current Consumption : No defect

- * Each test item uses a test LCD only once. The tested LCD is not used in any other tests.
- * The LCD is tested in circumstances in which there is no condensation.
- * The tested LCD is inspected after 24 hours of storage at room temperature and room humidity after each test is finished.
- * The reliability test is not an out-going inspection.
- * The results of the reliability test are for your reference purpose only. The reliability test is conducted only to examine the LCD's capability.

No	Description	Drawn	Checked	Checked	Approved
△	-Change Connector(LEAD FREE). -Add Matching Connector(LEAD FREE). -Change Scale Back side drawing.	'05.01.12 倉元	'05.01.12 川田原		'05.01.12 阿部

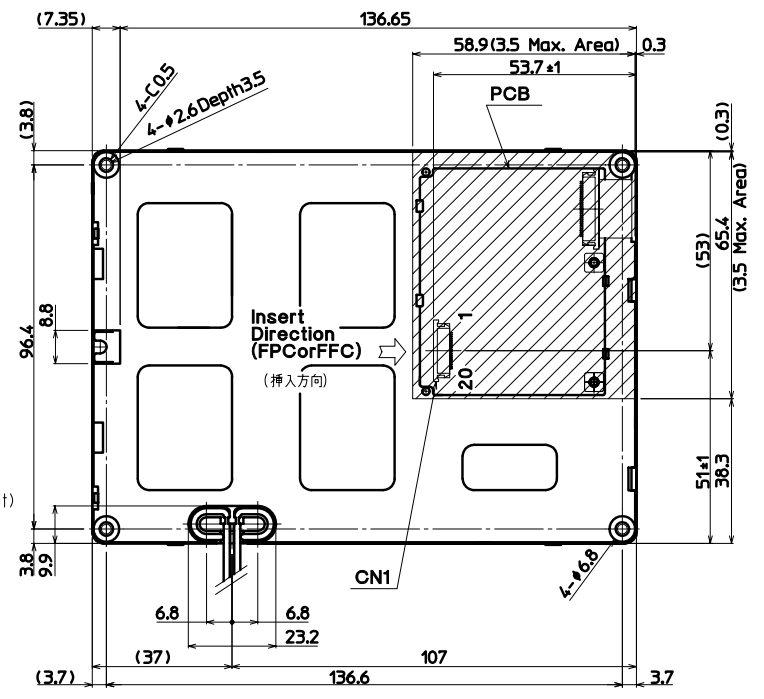
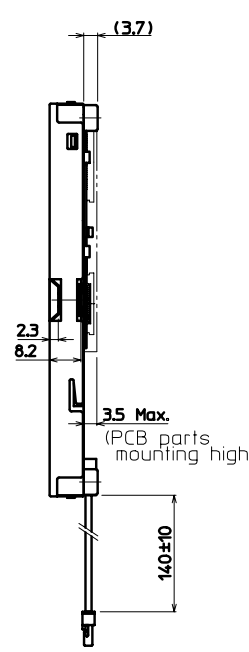
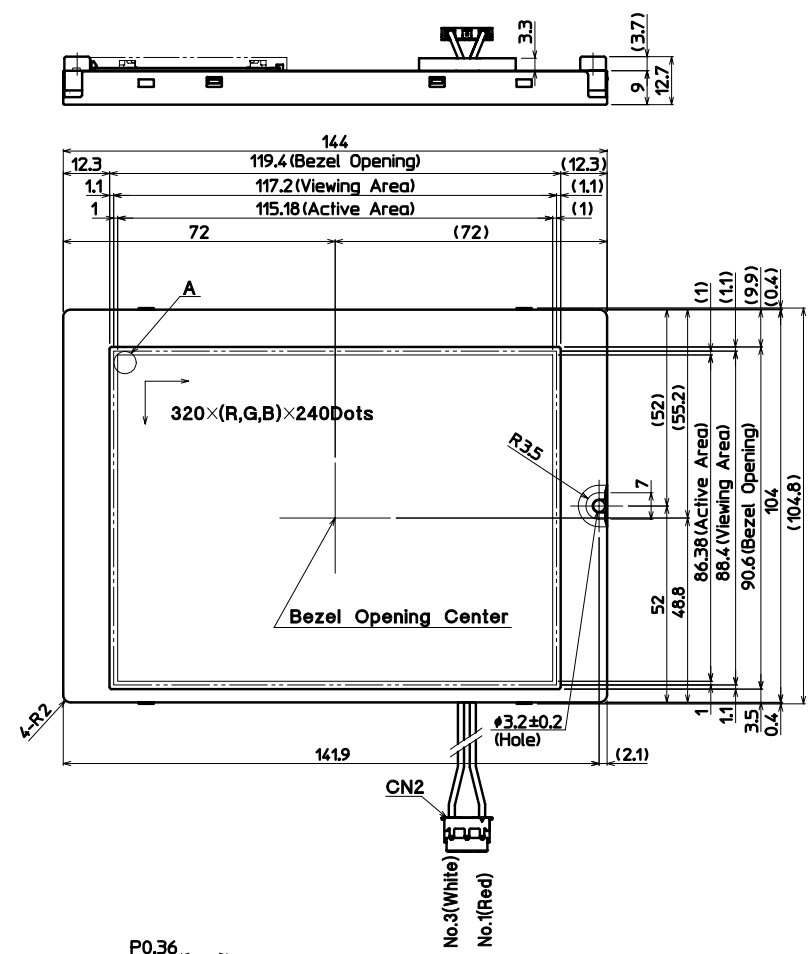

△ Back side drawing (1:2)

(Note.) △08-6210-020-340-800+
 1. Connector CN1: ~~08-6210-020-340-800~~ (ELCO)
 (コネクタ) CN2: BHR-03VS-1(JST)
 2. Matching Connector CN2: SM02-(8.0)B-BHS-1 (JST)
 (適合コネクタ) △ SM02-(8.0)B-BHS-1-TB-(LF)(SN) (JST)
 3. The drawing is the front view of the LCD.
 Information is displayed starting at the upper left hand corner, moving right then down to the lower right hand corner.
 (LCDの正面図において、画像データの表示は左上コーナーから始まり、右へ進み下へ送られ右下コーナーへ向かう。)
 4. Tolerance without indication: ±0.5
 (指示無き公差)

Material 材質	Treatment 処理	Approved '02.07.26	Checked '02.07.26	Checked 今村	Drawn 倉元	Scale 1:1(1:2,NTS)	Title KCG057QV1DB	Year-Month-Day '02.07.26	Size 2
Quantity 製作数	Description 備考	05006AAA		阿部			Outline Dimensions	Drawing No. 121A5018300-1	

SPEC. NO.	TQ3C-8EAC0-E2CUP57-00
DATE	January 31, 2006

FOR : _____

KYOCERA INSPECTION STANDARD

TYPE : KCG057QV1DB-G77

KYOCERA CORPORATION
KAGOSHIMA HAYATO PLANT
LCD DIVISION

Original	Designed by :Engineering Dept.			Confirmed by :QA Dept.	
Issue Date	Prepared	Checked	Approved	Checked	Approved
January 31, 2006	<i>H. Nishino</i>	<i>Y. Yamaguchi</i>	<i>M. Fujitani</i>	<i>Y. Matsumoto</i>	<i>S. Higashi</i>

Revision Record

Date	Designed by: Engineering Dept.			Confirmed by: QA Dept.	
	Prepared	Checked	Approved	Checked	Approved
Rev. No.	Date	Page	Descriptions		

Visuals specification

1)Note

Item	Note
General	<p>1. When defects specified in this Inspection Standards are inspected, operating voltage(Vop) shall be set at the level where optimized contrast is available. Display quality is applied up to effective viewing area. (Bi-Level INSPECTION)</p> <p>2. This inspection standard about the image quality shall be applied to any defect within the effective viewing area and shall not be applicable to outside of the area.</p> <p>3. Should any defects which are not specified in this standard happen, additional standard shall be determined by mutual agreement between customer and Kyocera.</p> <p>4. Inspection conditions</p> <p>Luminance : 500 Lux minimum . Inspection distance : 300 mm (from the sample) Temperature : 25 ± 5 °C Direction : right above</p>
Definition of Inspection item	<p>Pinhole, Bright spot Black spot, Scratch Foreign particle</p> <p>The color of a small area is different from the remainder. The phenomenon does not change with voltage.</p>
	<p>Contrast variation</p> <p>The color of a small area is different from the remainder. The phenomenon changes with voltage.</p>
	<p>Polarizer (Scratch, Bubble, Dent)</p> <p>Scratch, Bubble and Dent in the polarizer which can be observed in on / off state.</p>

2) Standard

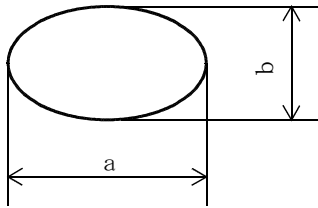
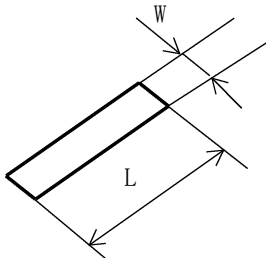
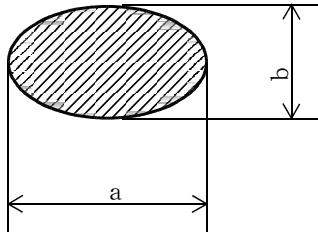
Inspection item	Judgement standard																						
Pinhole, Bright spot Black spot, Foreign particle	<div style="text-align: center;">  $d = (a + b) / 2$ <table border="1" data-bbox="587 566 1393 801"> <thead> <tr> <th>Category</th> <th>Size (mm)</th> <th>Acceptable number</th> </tr> </thead> <tbody> <tr> <td>A</td> <td>$d \leq 0.2$</td> <td>neglected</td> </tr> <tr> <td>B</td> <td>$0.2 < d \leq 0.3$</td> <td>5</td> </tr> <tr> <td>C</td> <td>$0.3 < d \leq 0.5$</td> <td>3</td> </tr> <tr> <td>D</td> <td>$0.5 < d$</td> <td>0</td> </tr> </tbody> </table> </div>	Category	Size (mm)	Acceptable number	A	$d \leq 0.2$	neglected	B	$0.2 < d \leq 0.3$	5	C	$0.3 < d \leq 0.5$	3	D	$0.5 < d$	0							
Category	Size (mm)	Acceptable number																					
A	$d \leq 0.2$	neglected																					
B	$0.2 < d \leq 0.3$	5																					
C	$0.3 < d \leq 0.5$	3																					
D	$0.5 < d$	0																					
Scratch, Foreign particle	<div style="text-align: center;">  <table border="1" data-bbox="557 1171 1422 1473"> <thead> <tr> <th></th> <th>Width (mm)</th> <th>Length (mm)</th> <th>Acceptable No.</th> </tr> </thead> <tbody> <tr> <td>A</td> <td>$W \leq 0.03$</td> <td>—</td> <td>neglected</td> </tr> <tr> <td>B</td> <td rowspan="3">$0.03 < W \leq 0.1$</td> <td>$L \leq 2.0$</td> <td>neglected</td> </tr> <tr> <td>C</td> <td>$2.0 < L \leq 4.0$</td> <td>3</td> </tr> <tr> <td>D</td> <td>$4.0 < L$</td> <td>0</td> </tr> <tr> <td>E</td> <td>$0.1 < W$</td> <td>—</td> <td>According to Circular</td> </tr> </tbody> </table> </div>		Width (mm)	Length (mm)	Acceptable No.	A	$W \leq 0.03$	—	neglected	B	$0.03 < W \leq 0.1$	$L \leq 2.0$	neglected	C	$2.0 < L \leq 4.0$	3	D	$4.0 < L$	0	E	$0.1 < W$	—	According to Circular
	Width (mm)	Length (mm)	Acceptable No.																				
A	$W \leq 0.03$	—	neglected																				
B	$0.03 < W \leq 0.1$	$L \leq 2.0$	neglected																				
C		$2.0 < L \leq 4.0$	3																				
D		$4.0 < L$	0																				
E	$0.1 < W$	—	According to Circular																				
Contrast variation	<div style="text-align: center;">  $d = (a + b) / 2$ <table border="1" data-bbox="587 1821 1393 2011"> <thead> <tr> <th>Category</th> <th>Size (mm)</th> <th>Acceptable number</th> </tr> </thead> <tbody> <tr> <td>A</td> <td>$d \leq 0.5$</td> <td>neglected</td> </tr> <tr> <td>B</td> <td>$0.5 < d \leq 0.7$</td> <td>3</td> </tr> <tr> <td>C</td> <td>$0.7 < d$</td> <td>0</td> </tr> </tbody> </table> </div>	Category	Size (mm)	Acceptable number	A	$d \leq 0.5$	neglected	B	$0.5 < d \leq 0.7$	3	C	$0.7 < d$	0										
Category	Size (mm)	Acceptable number																					
A	$d \leq 0.5$	neglected																					
B	$0.5 < d \leq 0.7$	3																					
C	$0.7 < d$	0																					

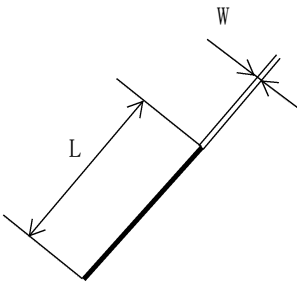
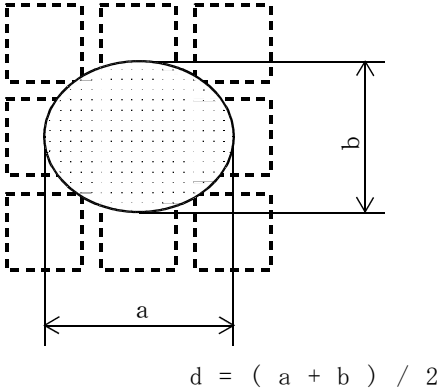
Inspection item	Judgement standard																			
Polarizer (Scratch, Bubble, Dent)	<p data-bbox="544 248 708 277">(1) Scratch</p>  <table border="1" data-bbox="560 689 1422 1021"> <thead> <tr> <th></th> <th>Width (mm)</th> <th>Length (mm)</th> <th>Acceptable No.</th> </tr> </thead> <tbody> <tr> <td>A</td> <td>$W \leq 0.1$</td> <td>—</td> <td>neglected</td> </tr> <tr> <td>B</td> <td rowspan="2">$0.1 < W \leq 0.3$</td> <td>$L \leq 5.0$</td> <td>neglected</td> </tr> <tr> <td>C</td> <td>$5.0 < L$</td> <td>0</td> </tr> <tr> <td>D</td> <td>$0.3 < W$</td> <td>—</td> <td>0</td> </tr> </tbody> </table>		Width (mm)	Length (mm)	Acceptable No.	A	$W \leq 0.1$	—	neglected	B	$0.1 < W \leq 0.3$	$L \leq 5.0$	neglected	C	$5.0 < L$	0	D	$0.3 < W$	—	0
	Width (mm)	Length (mm)	Acceptable No.																	
A	$W \leq 0.1$	—	neglected																	
B	$0.1 < W \leq 0.3$	$L \leq 5.0$	neglected																	
C		$5.0 < L$	0																	
D	$0.3 < W$	—	0																	
	<p data-bbox="544 1070 807 1099">(2)Bubble (dent)</p>  <table border="1" data-bbox="587 1675 1393 2007"> <thead> <tr> <th>Category</th> <th>Size (mm)</th> <th>Acceptable number</th> </tr> </thead> <tbody> <tr> <td>A</td> <td>$d \leq 0.2$</td> <td>neglected</td> </tr> <tr> <td>B</td> <td>$0.2 < d \leq 0.3$</td> <td>5</td> </tr> <tr> <td>C</td> <td>$0.3 < d \leq 0.5$</td> <td>3</td> </tr> <tr> <td>D</td> <td>$0.5 < d$</td> <td>0</td> </tr> </tbody> </table>	Category	Size (mm)	Acceptable number	A	$d \leq 0.2$	neglected	B	$0.2 < d \leq 0.3$	5	C	$0.3 < d \leq 0.5$	3	D	$0.5 < d$	0				
Category	Size (mm)	Acceptable number																		
A	$d \leq 0.2$	neglected																		
B	$0.2 < d \leq 0.3$	5																		
C	$0.3 < d \leq 0.5$	3																		
D	$0.5 < d$	0																		