

SPEC. NO.	TQ3C-8EAC0-E1CUP73-00
DATE	May 20, 2006

S P E C

FOR : _____

TYPE : KCG057QVLDG-G00

CONTENTS

1. Application
2. Construction and Outline
3. Mechanical Specifications
4. Absolute Maximum Ratings
5. Electrical Characteristics
6. Optical Characteristics
7. Circuit Block Diagram
8. Interface Signals
9. Interface Timing Chart
10. Input Timing Characteristics
11. Supply Voltage Sequence Condition
12. LED Backlight Characteristics
13. Lot Number Identification
14. Warranty
15. Precautions for Use
16. Reliability Data / Environmental Test
17. Outline Drawing

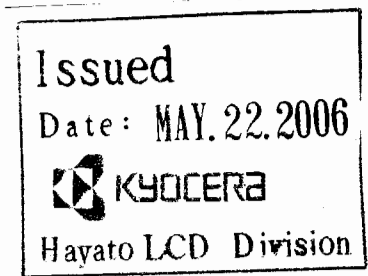

KYOCERA CORPORATION
KAGOSHIMA HAYATO PLANT
LCD DIVISION

This specification is subject to change without notice.
Consult Kyocera before ordering.

Original	Designed by :Engineering Dept.			Confirmed by :QA Dept.	
Issue Date	Prepared	Checked	Approved	Checked	Approved
May 20, 2006	<i>H. Nishino</i>	<i>Y. Yamaguchi</i>	<i>M. Fujitani</i>	<i>Ke. Itoh</i>	<i>T. Minami</i>

Caution

1. This Kyocera LCD module has been specifically designed for use only in electronic devices in the areas of audio control, office automation, industrial control, home appliances, etc. The modules should not be used in applications where module failure could result in physical harm or loss of life, and Kyocera expressly disclaims any and all liability relating in any way to the use of the module in such applications.
2. Customer agrees to indemnify, defend and hold Kyocera harmless from and against any and all actions, claims, losses, damages, liabilities, awards, costs, and expenses, including legal fees, resulting from or arising out of Customer's use, or sale for use, of Kyocera modules in applications.
3. Kyocera shall have the right, which Customer hereby acknowledges, to immediately scrap or destroy tooling for Kyocera modules for which no Purchase Orders have been received from the Customer in a two-year period.

Revision Record

Date	Designed by: Engineering Dept.			Confirmed by: QA Dept.	
	Prepared	Checked	Approved	Checked	Approved
Rev. No.	Date	Page	Descriptions		

1. Application

This data sheet defines the specification for a $(320 \times R.G.B) \times 240$ dot, STN Transmissive color dot matrix type Liquid Crystal Display with LED backlight. 『RoHS Compliant』

2. Construction and Outline

$(320 \times R.G.B) \times 240$ dots, COG type LCD with LED backlight.

Backlight system : Side-edge type (LED).

Polarizer : Glare treatment.

Additional circuit : Bias voltage circuit, Randomizing circuit, DC-DC Converter, Temperature Compensation Circuit (for Contrast).

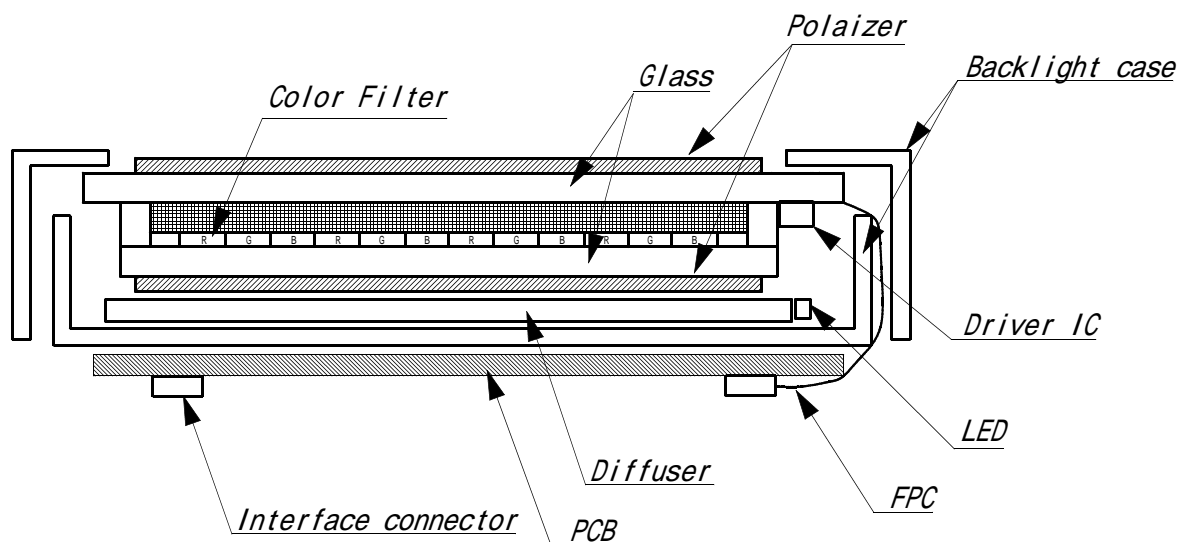

This drawing is showing conception only.

3. Mechanical Specifications

ITEM	SPECIFICATION	UNIT
Outline dimensions	144 (W) × 104.8 (H) × 12.7 (D) (PCB and bosses are not included) Refer outline drawing in detail.	mm
Effective viewing area	117.2 (W) × 88.4 (H)	mm
Dot number	(320 × R.G.B) (W) × 240 (H)	Dots
Dot size	0.10 (W) × 0.34 (H)	mm
Dot pitch	0.12 (W) × 0.36 (H)	mm
Display color *1	White *2	-
Base color *1	Black *2	-
Mass	175	g

*1 Due to the characteristics of the LC material, the color vary with environmental temperature.

*2 Negative-type display

Display data "H" :R.G.B Dots ON : White

Display data "L" :R.G.B Dots OFF : Black

4. Absolute Maximum Ratings

4-1. Electrical absolute maximum ratings

ITEM	SYMBOL	MIN.	MAX.	UNIT
Supply voltage for logic	VDD	0	6.0	V
Supply voltage for LCD driving	VCONT	0	VDD	V
Input signal voltage for LCD *1	Vin	0	VDD	V
LED forward current (Backlight) *2	IF	-	(27)	mA
Reversed voltage *2	VR	-	(5)	V

*1 Input signal : CP, LOAD, FRM, DISP, D0 ~ D7

*2 For each "AN1-CA1", "AN2-CA2" and "AN3-CA3"

4-2. Environmental absolute maximum ratings

ITEM	SYMBOL	MIN	MAX	UNIT
Operating temperature *1	Top	0	60	
Storage temperature *2	T _{STO}	-20	60	
Operating humidity *3	H _{op}	10	*4	%RH
Storage humidity *3	H _{STO}	10	*4	%RH
Vibration	-	*5	*5	-
Shock	-	*6	*6	-

*1 LCD's display quality shall not be guaranteed at the temperature range of :
below 0 and upper 40 .

*2 Temp. = -20 < 48 h , Temp = 60 < 168 h
Store LCD panel at normal temperature/humidity.
Keep it free from vibration and shock.
LCD panel that is kept at low or high temperature for a long time can be defective due to
the other conditions, even if the temperature satisfies standard.
(Please refers to 16. Precautions for use as detail).

*3 Non-condensation.

*4 Temp. 40 , 85% RH Max.
Temp. > 40 , Absolute Humidity shall be less than 85%RH at 40 .

*5

Frequency	10 ~ 55 Hz	Converted to acceleration value : (0.3 ~ 9 m/s ²)
Vibration width	0.15 mm	
Interval	10-55-10 Hz 1 minute	

2 hours in each direction X/Y/Z (6 hours as total)
EIAJ ED-2531

*6 Acceleration: 490m/s²
Pulse width : 11 ms
3 times in each direction : ±X/ ±Y/ ±Z.
EIAJ ED-2531

5. Electrical Characteristics

5-1. VDD = 5.0V

VDD = +5.0V ± 5%, Temp. = 0 ~ 60

ITEM	SYMBOL	CONDITION	MIN.	TYP.	MAX.	UNIT
Supply voltage for logic	VDD	-	4.75	5.00	5.25	V
LCD driving voltage *1 *2	Vop= VCONT	0 ~ 50	1.30	1.80	2.30	V
		~ 60	-	-	2.40	V
Input voltage (FRM,LOAD,CP,DISP,D0 ~ D7)	Vin	"H" level	0.8VDD	-	VDD	V
		"L" level	0	-	0.2VDD	V
Input current	Iin	Input signal	-100	-	100	μA
Rush current for logic	Irush	When rush current happens	3.0A(Peak) × 1ms			
Clock frequency	fcp	-	2.02	2.16	10.00	MHz
Frame frequency *3	f _{FRM}	-	70	75	150	Hz
Current consumption for logic	IDD	*3	-	27.0	40.5	mA
Power consumption	Pdisp		-	135.0	202.5	mW

- *1 Maximum contrast is obtained by adjusting the LCD driving voltage (Vop=Vcont) while at the viewing angle of = 0°
- *2 The LCD has temperature compensation circuit.
- *3 In consideration of display quality, it is recommended that frame frequency is set in the range of 70-80Hz. When you have to use higher frame and clock frequencies, confirm the LCD's performance and quality prior to finalizing the frequency values:
Generally, as frame and clock frequencies become higher, current consumption will get bigger and display quality will be degraded.

- *4 Display high frequency pattern, (see below).
VDD = 5.0V , Vop = VCONT , f_{FRM} = 75 Hz , fcp = 2.16MHz, Temp. = 25
Pattern:

```

123 456 789 101112 . . . . . 958,959,960 ( d o t )

1
2
3
:
:
:
2 3 9
2 4 0
( d o t )

```

5-2. VDD = 3.3V

VDD = +3.3V ± 0.3V, Temp. = 0 ~ 60

ITEM	SYMBOL	CONDITION	MIN.	TYP.	MAX.	UNIT
Supply voltage for logic	VDD	-	3.0	3.3	3.6	V
LCD driving voltage *1 *2	Vop= VCONT	0 ~ 50	1.30	1.80	2.30	V
		~ 60	-	-	2.40	V
Input voltage (FRM, LOAD, CP, DISP, D0 ~ D7)	Vin	"H" level	0.8VDD	-	VDD	V
		"L" level	0	-	0.2VDD	V
Input current	Iin	Input signal	-100	-	100	μA
Rush current for logic	Irush	When rush current happens	3.0A(Peak) × 1ms			
Clock frequency	fcp	-	2.02	2.16	10.00	MHz
Frame frequency *2	fFRM	-	70	75	150	Hz
Current consumption for logic	IDD	*3	-	40.5	60.8	mA
Power consumption	Pdisp		-	133.7	200.6	mW

*1 Maximum contrast is obtained by adjusting the LCD driving voltage (Vop=Vcont) while at the viewing angle of = 0°

*2 The LCD has temperature compensation circuit.

*3 In consideration of display quality, it is recommended that frame frequency is set in the range of 70-80Hz. When you have to use higher frame and clock frequencies, confirm the LCD's performance and quality prior to finalizing the frequency values:
Generally, as frame and clock frequencies become higher, current consumption will get bigger and display quality will be degraded.

*4 Display high frequency pattern, (see below).
VDD = 3.3V , Vop = VCONT , fFRM = 75 Hz , fcp = 2.16MHz, Temp. = 25
Pattern:

```

123 456 789 101112 . . . . . 958,959,960 ( d o t )
1
2
3
:
:
2 3 9
2 4 0
( d o t )

```

6 . Optical Characteristics

Temp. = 25

ITEM		SYMBOL	CONDITION	MIN.	TYP.	MAX.	UNIT	
Response time	Rise	Tr	= =0 °	-	180	280	ms	
	Down	Td	= =0 °	-	170	270	ms	
Viewing angle range			CR 2	Upper	-	20	-	deg.
				Lower	-	35	-	
				Left	-	50	-	deg.
				Right	-	50	-	
Contrast ratio		CR	= =0 °	30	55	-	-	
Brightness		L	(IF=(25)mA/LED line)	(110)	(180)	-	cd/m ²	
Chromaticity coordinates	Red	x	= =0 °	(TBD)	(TBD)	(TBD)	-	
		y		(TBD)	(TBD)	(TBD)		
	Green	x	= =0 °	(TBD)	(TBD)	(TBD)		
		y		(TBD)	(TBD)	(TBD)		
	Blue	x	= =0 °	(TBD)	(TBD)	(TBD)		
		y		(TBD)	(TBD)	(TBD)		
	White	x	= =0 °	(TBD)	(TBD)	(TBD)		
		y		(TBD)	(TBD)	(TBD)		

Optimum contrast is obtained by adjusting the LCD driving voltage(Vop) while at the viewing angle of = = 0 ° .

6-1. Contrast ratio is defined as follows:

$$CR = \frac{\text{Brightness at all pixels "White"}}{\text{Brightness at all pixels "Black"}}$$

6-2. Definition of Vop

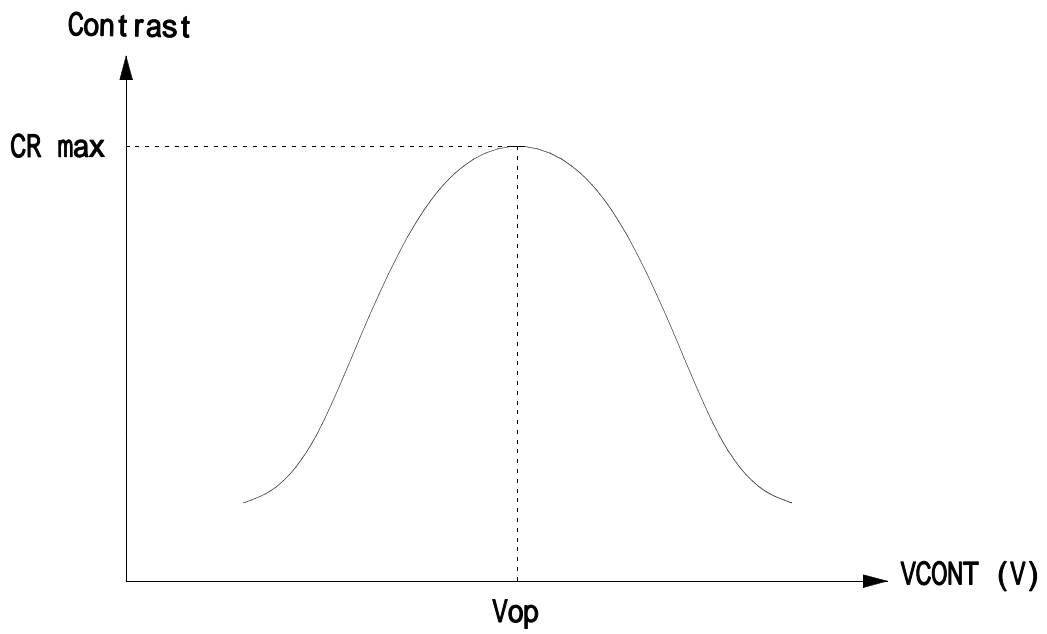

6-3. Definition of response time

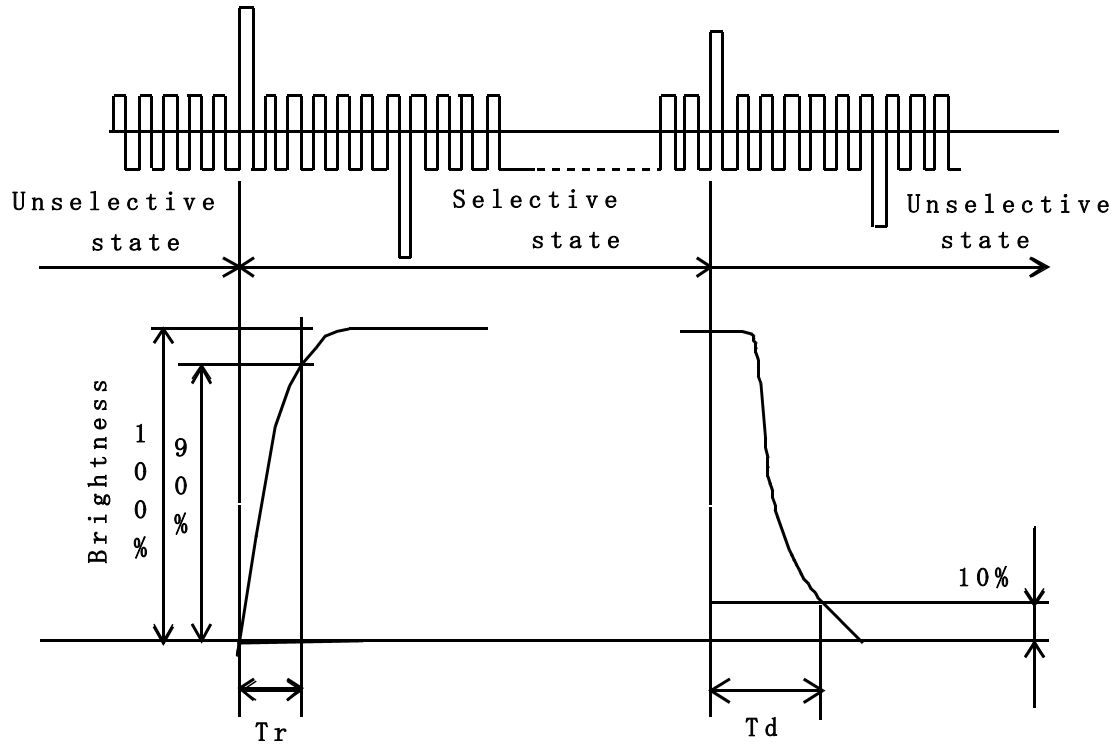

6-4. Definition of viewing angle

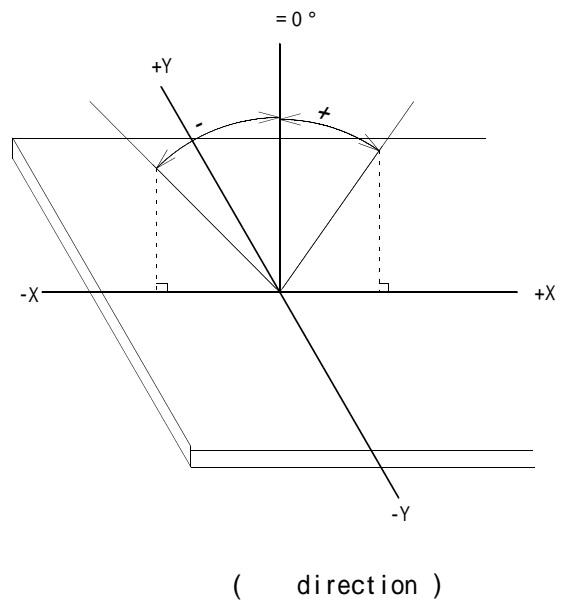
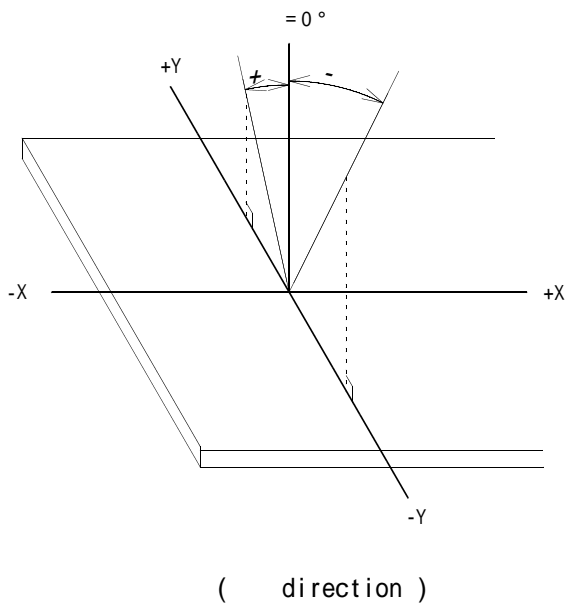

6-5. Measuring points

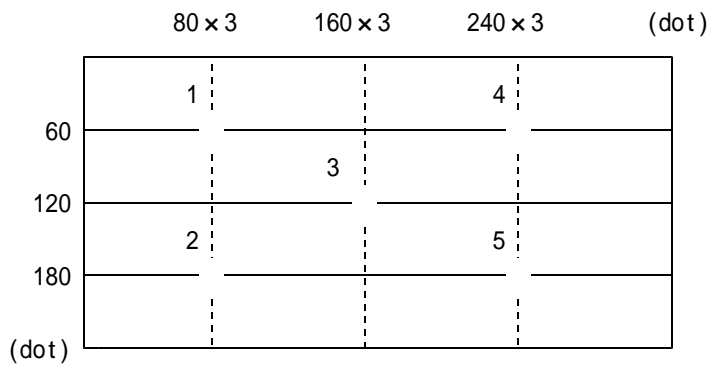

- 1) Rating is defined as the average brightness inside the viewing area.
- 2) 30 minutes after LED is turned on. (Ambient Temp.=25)
- 3) Backlight : IF=25mA/1 LED line

7. Circuit Block Diagram

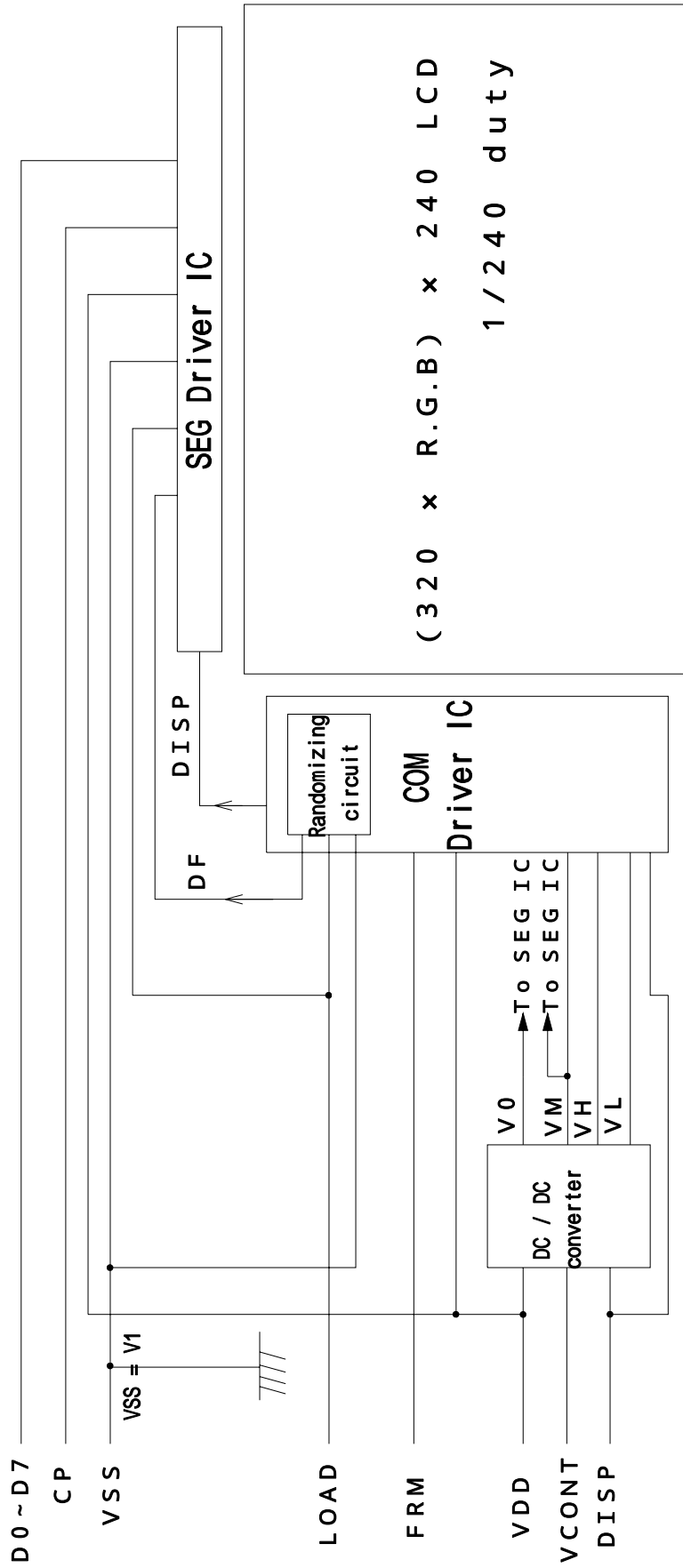

7-1. Power supply

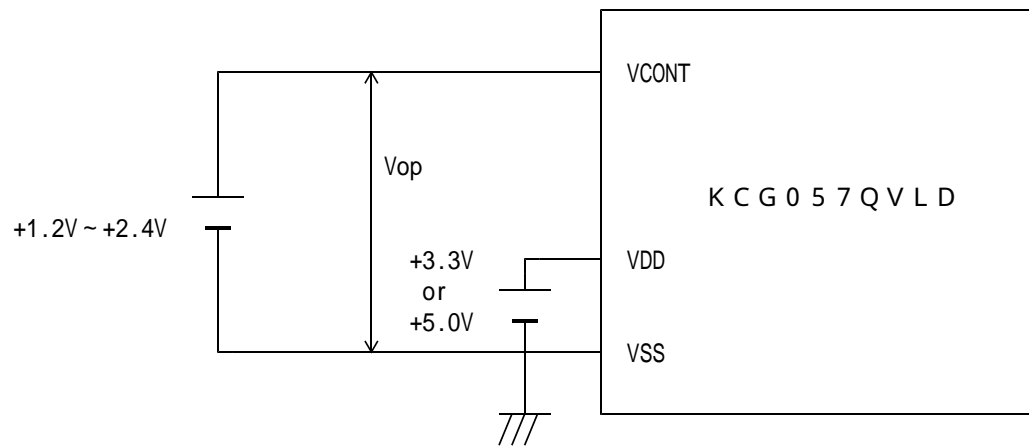

8. Interface signals

8-1. LCD

PIN	SYMBOL	DESCRIPTION	LEVEL
1	FRM	Synchronous signal for driving scanning line	H
2	LOAD	Data signal latch clock	H L
3	CP	Data signal shift clock	H L
4	DISP	Display control signal	H(ON),L(OFF)
5	VDD	Power supply for logic	
6	VSS	GND	
7	VCONT	LCD adjust voltage	
8	D7	Display data	H(ON),L(OFF)
9	D6		
10	D5		
11	D4		
12	D3		
13	D2		
14	D1		
15	D0		
16	VDD	Power supply for logic	-
17	VDD		
18	VSS	GND	-
19	VSS		
20	VSS		
20	VSS		

LCD connector : 08-6210-020-340-800+ (ELCO)

Recommended matching connector : 0.5 mm pitch FFC or FPC

8-2. LED Backlight

PIN No.	SYMBOL	DESCRIPTION
1	AN1	Anode1
2	AN2	Anode2
3	AN3	Anode3
4	CA1	Cathode1
5	CA2	Cathode2
6	CA3	Cathode3

LED Backlight side connector : SHLP-06V-S-B (JST)

Recommended matching connector : SM06B-SHLS-TF (JST)

: SM06B-SHLS-TF(LF)(SN) (JST) . . . (RoHS)

9 . Interface Timing Chart

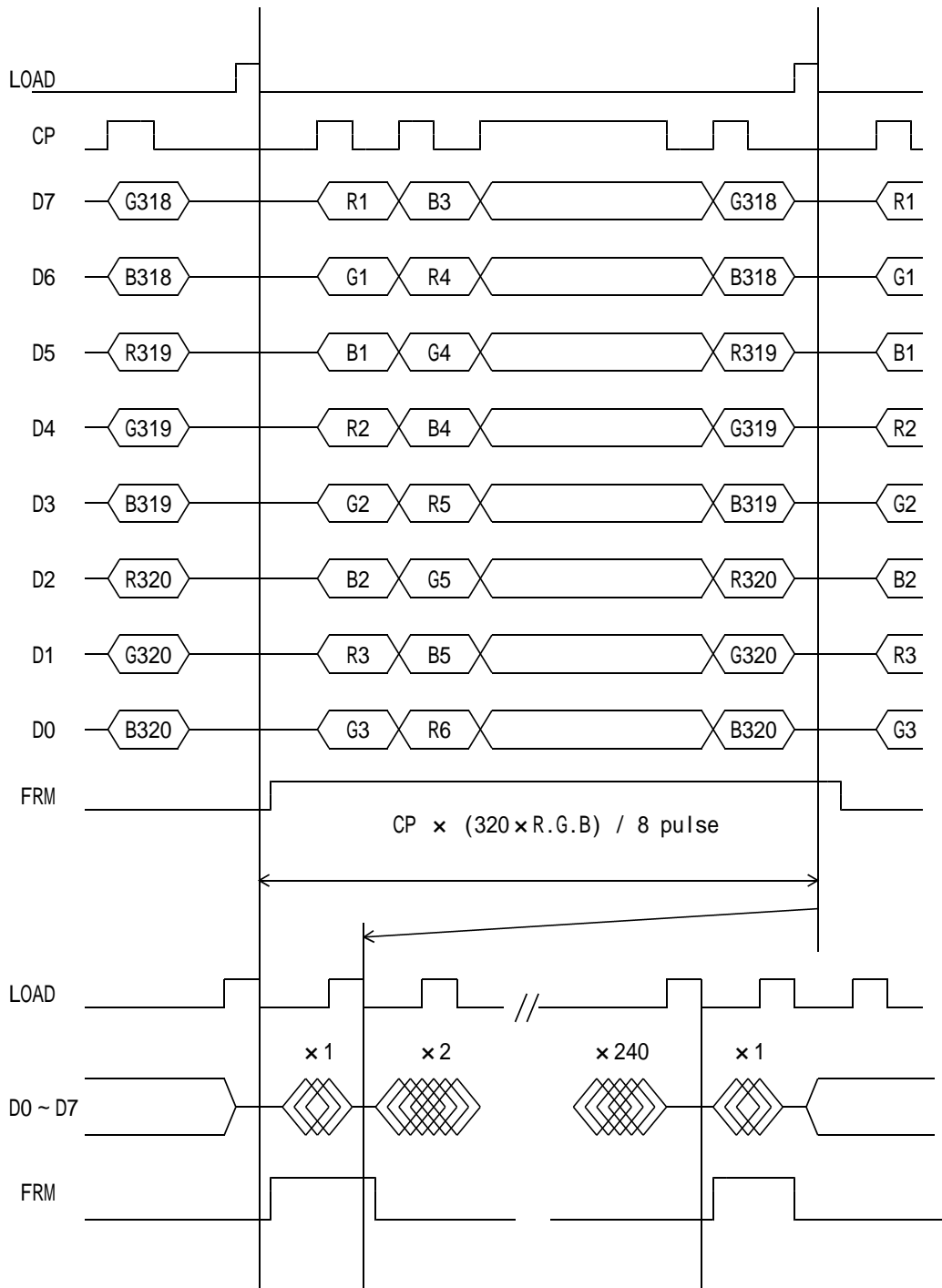

* The cycle of load signal should be stable and continuously applied without interruption.

* The above-mentioned timing chart shows a reference to set up a LCD module, not an electrical rating.

1 0 . Data and Screen

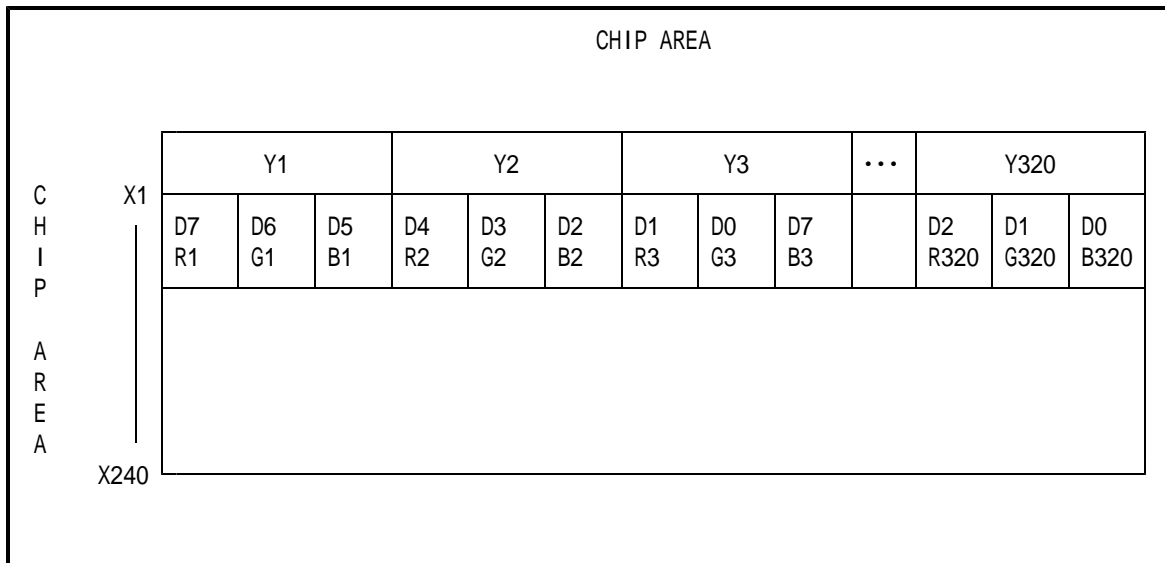

1 1 . Input Timing Characteristics

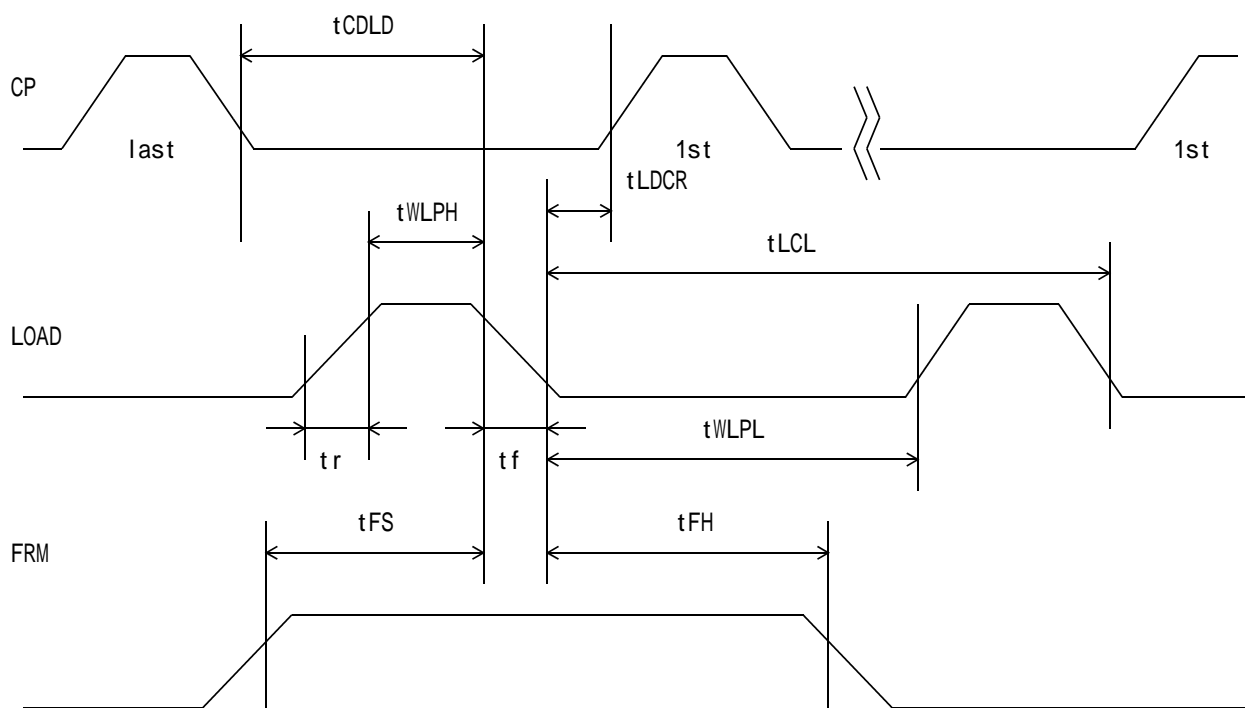
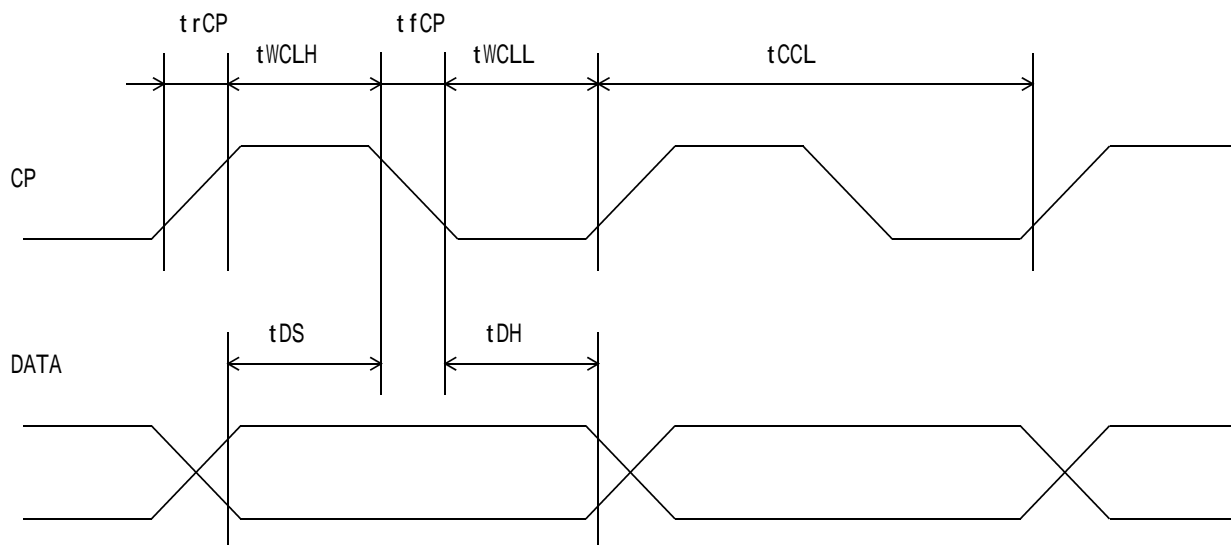

11-1. Switching characteristics (VDD = 5.0V)

Input Characteristics ; VDD = +5.0V \pm 5%, Temp. = 0~60

ITEM	SYMBOL	MIN.	MAX.	UNIT
CP Cycle *1	tCCL	100	-	ns
CP "H" Pulse Width	tWCLH	30	-	ns
CP "L" Pulse Width	tWCLL	30	-	ns
CP Rise Up Time	trCP	-	15	ns
CP Fall Down Time	tfCP	-	15	ns
Data Set Up Time	tDS	25	-	ns
Data Hold Time	tDH	25	-	ns
LOAD "H" Pulse Width	tWLPH	40	-	ns
LOAD "L" Pulse Width	tWLPL	400	-	ns
LOAD Cycle *2	tLCL	500	-	ns
CP Down LOAD Down Delay Time	tCDLD	60	-	ns
LOAD Down CP Rise Delay Time	tLDCR	60	-	ns
Input Signal Rise Up Time	tr	-	20	ns
Input Signal Fall Down Time	tf	-	20	ns
FRM Data Set Up Time	tFS	120	-	ns
FRM Data Hold Time	tfH	30	-	ns

*1 CP Cycle is adjust so that FRM signal is 75Hz.

*2 LOAD Cycle is const.

11-2. Switching characteristics (VDD = 3.3V)

Input Characteristics ; VDD = +3.3V ± 0.3V, Temp. = 0~60

ITEM	SYMBOL	MIN.	MAX.	UNIT
CP Cycle *1	tCCL	100	-	ns
CP "H" Pulse Width	tWCLH	40	-	ns
CP "L" Pulse Width	tWCLL	40	-	ns
CP Rise Up Time	trCP	-	20	ns
CP Fall Down Time	tfCP	-	20	ns
Data Set Up Time	tDS	35	-	ns
Data Hold Time	tDH	35	-	ns
LOAD "H" Pulse Width	tWLPH	50	-	ns
LOAD "L" Pulse Width	tWLPL	400	-	ns
LOAD Cycle *2	tLCL	500	-	ns
CP Down LOAD Down Delay Time	tCDLD	60	-	ns
LOAD Down CP Rise Delay Time	tLDCR	80	-	ns
Input Signal Rise Up Time	tr	-	20	ns
Input Signal Fall Down Time	tf	-	20	ns
FRM Data Set Up Time	tFS	120	-	ns
FRM Data Hold Time	tfH	30	-	ns

*1 CP Cycle is adjust so that FRM signal is 75Hz.

*2 LOAD Cycle is const.

1 2 . Supply Voltage Sequence Condition

DO NOT apply DC voltage to the LCD panel. DC voltage induce irreversible electrochemical reactions and reduce LCD life. Always follow the power supply ON/OFF sequence of VDD first, input signal second, VCONT third and finally DISP. This will prevent DC driving of the LCD or CMOS LSI latch up as shown below.

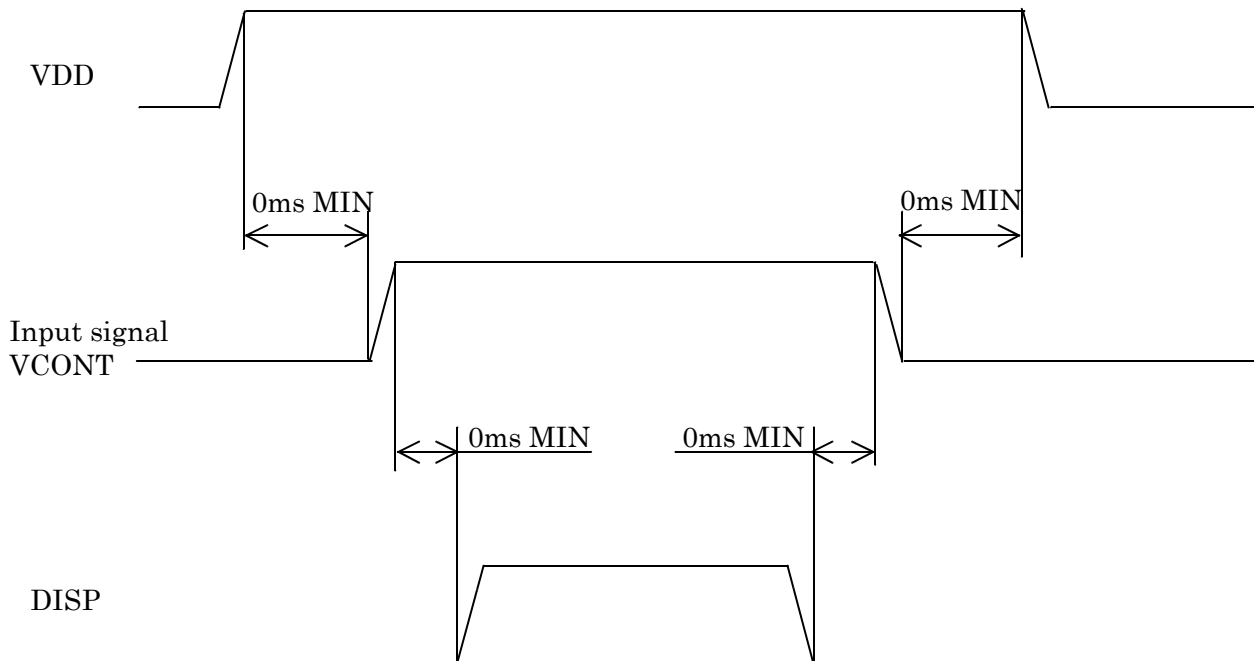

* Input signal : CP,LOAD,FRM,VCONT,D0 ~ D7

* The above sequence should be designed as to keep each normal figure on condition that liquid crystal module is loaded on your system.

* Control the input signal and VCONT to the above ON - OFF timing when you switch ON/OFF the display during VDD and DISP are on.
And design the circuit as VCONT's OFF level become GND level at the same time.

* Control the supply voltage sequence not to float all signal line when the LCD panel is driving.

1 3 . LED Backlight Characteristics

13-1. LED Backlight Characteristics

Temp. = 25

ITEM	SYMBOL	MIN.	TYP.	MAX.	UNIT	NOTE
Forward current *1	IF	-	(25)	-	mA	Ta=0 ~ 60
Forward voltage	VF	-	(23.8)	(26.6)	V	IF=(25)mA *1、 Ta=0
		-	(23.1)	(25.9)	V	IF=(25)mA *1、 Ta=25
		-	(22.3)	(25.1)	V	IF=(25)mA *1、 Ta=60
Operating time *2	T	-	(50,000) *3	-	V	IF=(25)mA *1

*1 For each "AN1-CA1", "AN2-CA2" and "AN3-CA3"

*2 When brightness decrease 50% of initial brightness.

*3 Life Time is estimated data.

* An input current below 8.0mA may reduce the brightness uniformity of the LED backlight.
This is because the amount of light from each LED chip is different. Therefore, please evaluate carefully before finalizing the input current.

1 4 . Lot Number Identification

The lot number shall be indicated on the back of the backlight case of each LCD.

K C G 0 5 7 Q V L D G - G 0 0 - _____ - MADE IN _____

YEAR
MONTH
DATA
Version Number
Country of origin (Japan or China)

YEAR	2006	2007	2008	2009	2010	2011
CODE	6	7	8	9	0	1

MONTH	JAN.	FEB.	MAR.	APR.	MAY	JUN.
CODE	1	2	3	4	5	6

MONTH	JUL.	AUG.	SEP.	OCT.	NOV.	DEC.
CODE	7	8	9	X	Y	Z

1 5 . Warranty

15-1. Incoming inspection

Please inspect the LCD within one month after your receipt.

15-2. Production Warranty

Kyocera warrants its LCDs for a period of 12 months after receipt by the purchaser, and within the limits specified. Kyocera shall, by mutual agreement, replace or rework defective LCDs that are shown to be Kyocera's responsibility.

1 6 . Precautions for use

16-1. Installation of the LCD

1. Please ground of an LCD module, in order to stabilize brightness and display quality.
2. The LCD shall be installed so that there is no pressure on the LSI chips.
3. The LCD shall be installed flat, without twisting or bending.
4. The display window size should be the same as the effective viewing area.
5. In case you use outside frame of effective viewing area as outward appearance of your product, unevenness of its outward appearance is out of guarantee.
6. A transparent protection sheet is attached to the polarizer. Please remove the protection film slowly before use, paying attention to static electricity.
7. Do not pull the LED lead wires and do not bend the root of the wires.
Housing should be designed to protect LED lead wires from external stress.
8. This Kyocera LCD module has been specifically designed for use in general electronic devices, but not for use in a special environment such as usage in an active gas.
Hence, when the LCD is supposed to be used in a special environment, evaluate the LCD thoroughly beforehand and do not expose the LCD to chemicals such as an active gas.
9. A clear protection sheet is affixed to the front polarizer of the LCD. Please be sure to remove it before mounting the LCD. We recommend using ESD safe measures when removing this protection sheet.

16-2. Static Electricity

1. Since CMOS ICs are mounted directly onto the LCD glass, protection from static electricity is required. Operation should wear ground straps.

16-3. LCD Operation

1. The LCD shall be operated within the limits specified. Operation at values outside of these limits may shorten life, and/or harm display images.
2. Adjust "LCD driving voltage" to obtain optimum viewing angle and contrast.
3. Operation of the LCD at temperature below the limit specified may cause image degradation and/or bubbles. It may also change the characteristics of the liquid crystal.
This phenomenon may not recover. The LCD shall be operated within the temperature limits specified.

16-4. Storage

1. The LCD shall be stored within the temperature and humidity limits specified.
Store in a dark area, and protected the LCD from direct sunlight or fluorescent light.
2. Always store the LCD so that it is free from external pressure onto it.

16-5. Screen Surface

1. DO NOT store in a high humidity environment for extended periods.
Image degradation, bubbles, and/or peeling off of polarizer may result.
2. The front polarizer is easily scratched or damaged.
Prevent touching it with any hard material, and from being pushed or rubbed.
3. The LCD screen may be cleaned with a soft cloth or cotton pad.
Methanol, or Isopropyl Alcohol may be used, but insure that all solvent residue is removed.
4. Water may cause damage or discoloration of the polarizer.
Clean any condensation or moisture from any source immediately.
5. Always keep the LCD free from condensation during testing.
Condensation may permanently spot or stain the polarizers.
6. Do not disassemble LCD module because it will result in damage.
7. Please do not use solid-base image pattern for long hours because a temporary afterimage may appear. We recommend to use screen saver etc. in cases where a solid-base image pattern must be used.
8. Liquid crystal may leak when the module is broken. Be careful not to let the fluid go into your eyes and mouth. In the case the fluid touches your body, rinse it off right away with water and soap.

1 7 . Reliability Data / Environmental Test

TEST ITEM	TEST CONDITION	TEST TIME	RESULT
High Temp. Atmosphere	60	240 h.	Display Quality : No defect Display Function : No defect Current Consumption : No defect
Low Temp. Atmosphere	-20	240 h.	Low Temp. Bubble : None Solid Crystallization of Liquid Crystal : None Display Quality : No defect Display Function : No defect Current Consumption : No defect
High Temp. Humidity Atmosphere	40 90%RH	240 h.	Display Quality : No defect Display Function : No defect Peel-off of Organic Sealing : None Current Consumption : No defect
Temp. Cycle	-20 0.5 h. R.T. 0.5 h. 60 0.5 h.	10cycles	Display Quality : No defect Display Function : No defect Peel-off of Organic Sealing : None Bubble on Cell : None
High Temp. Operation	60 Vop	500 h.	Display Quality : No defect Display Function : No defect Current Consumption : No defect

- * Each test item uses a test LCD only once. The tested LCD is not used in any other tests.
- * The LCD is tested in circumstances in which there is no condensation.
- * The tested LCD is inspected after 24 hours of storage at room temperature and room humidity after each test is finished.
- * The reliability test is not an out-going inspection.
- * The results of the reliability test are for your reference purpose only.
The reliability test is conducted only to examine the LCD's capability.

No	Description	Drawn	Checked	Checked	Approved

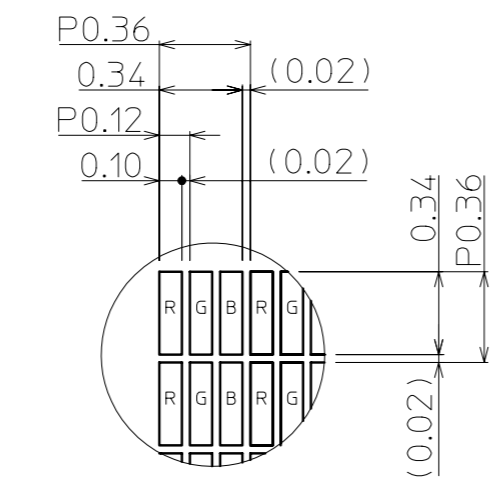
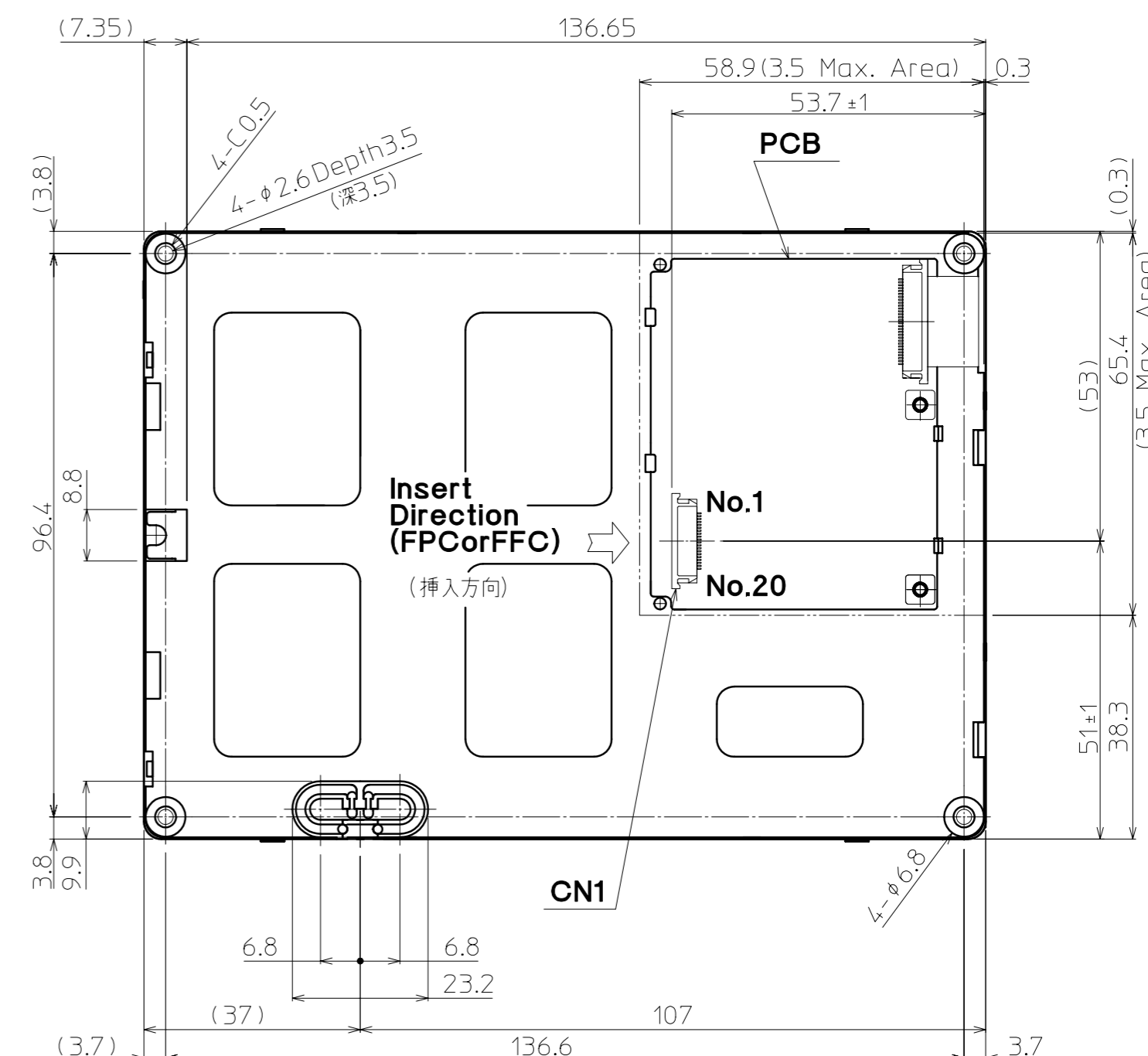
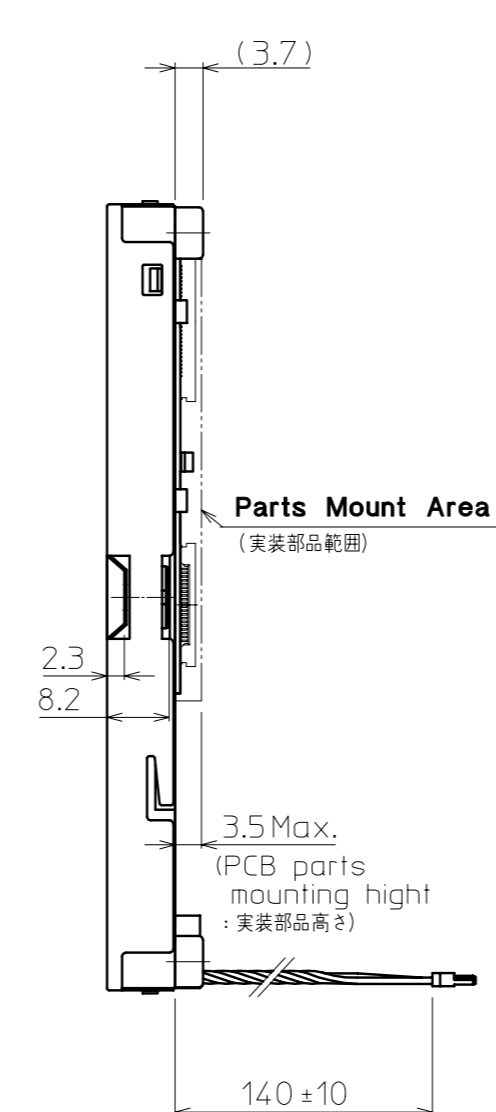
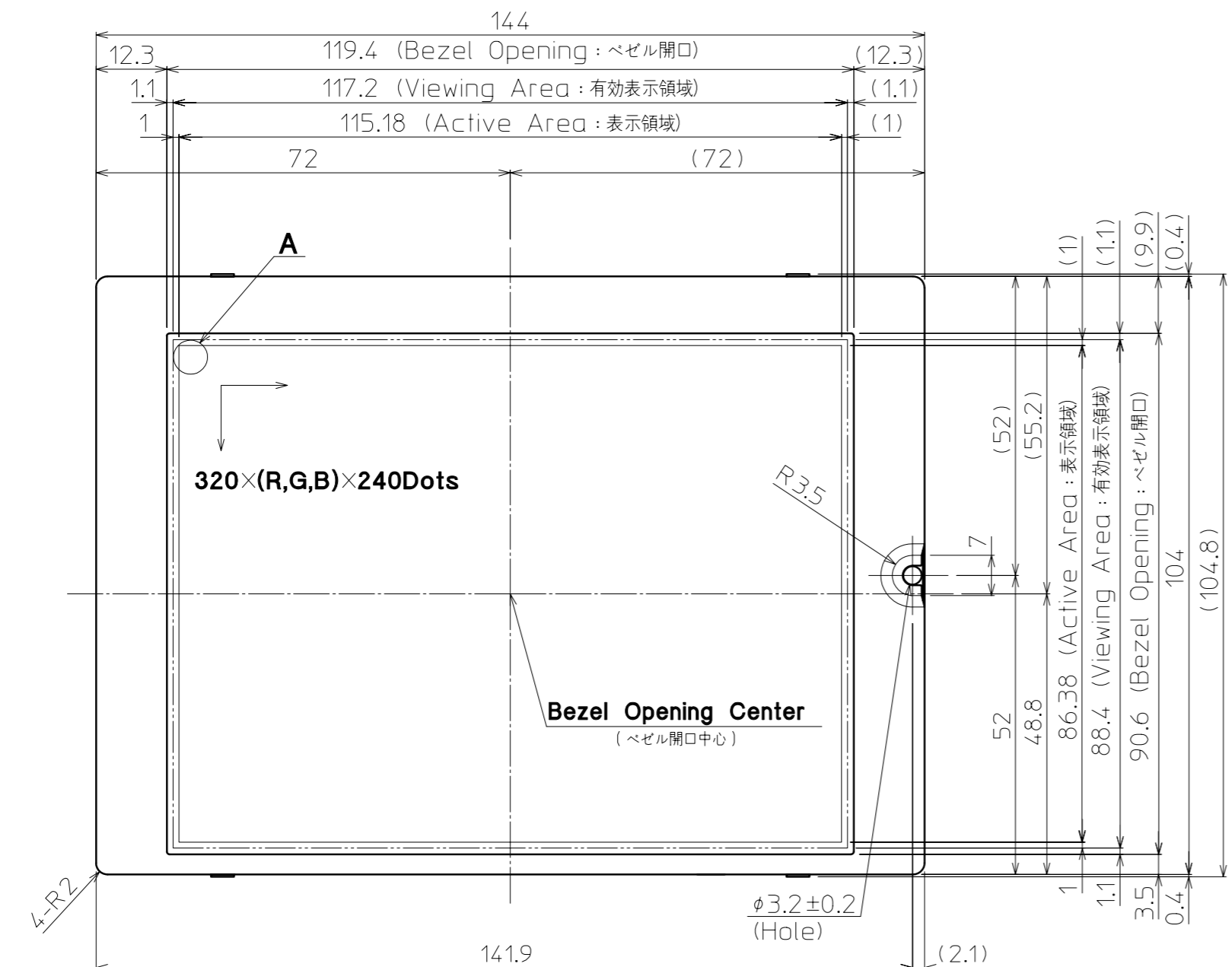
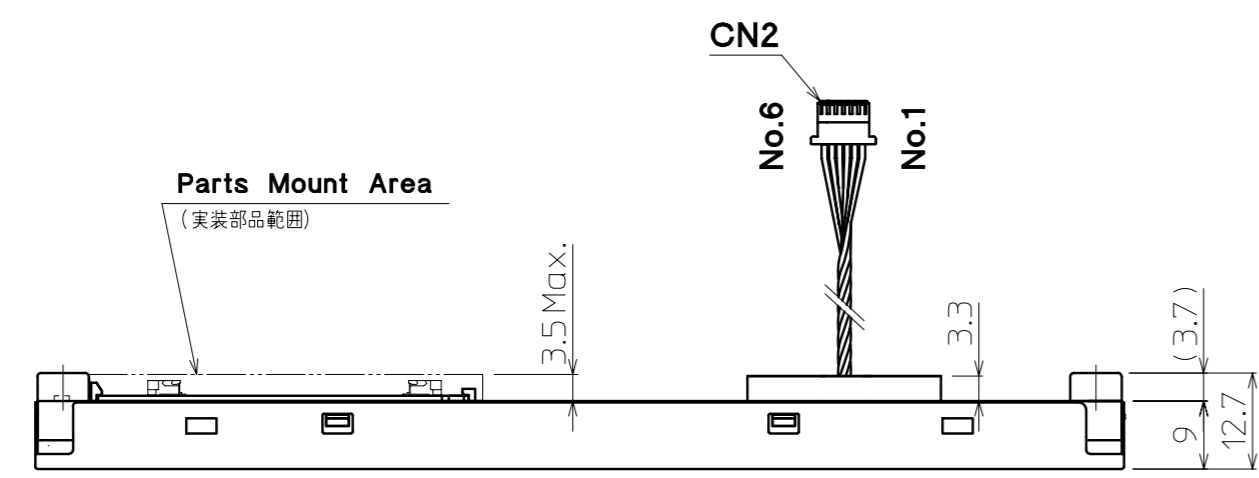

Detail A (Dot Size)
(NTS)

CN2 Pin Assign

No.	Description	Cable Color
No.1	Anode 1	Black(黒)
No.2	Anode 2	Red(赤)
No.3	Anode 3	White(白)
No.4	Cathode 1	Black(黒)
No.5	Cathode 2	Red(赤)
No.6	Cathode 3	White(白)

(Note.)

- Connector CN1: 08-6210-020-340-800+ (ELCO) (コネクタ) CN2: SHLP-06V-S-B (JST)
- Matching Connector CN2: SM06B-SHLS-TF (JST) (適合コネクタ) SM06B-SHLS-TF(LF)(SN) (JST)
- The Information of LCD is displayed starting at the upper left hand corner, moving right then down to the lower right hand corner. (LCDにおいて、画像データの表示は左上コーナーから始まり、右へ進み下へ送られ右下コーナーへ向かう。)
- Tolerance without indication: ±0.5 (指示無き公差)

Material 材質	Treatment 処理	Approved '06.05.20	Checked	Checked '06.05.20	Drawn 小林	Scale 1:1(NTS)	Title KCG057QVLDG	KYOCERA	Year-Month-Day '06.05.20	Size 2
Quantity 製作数	Description; 備考	RoHS 06006AAA	阿部	倉元			Outline Dimensions		Drawing No. 121A5049900	

SPEC. NO.	TQ3C-8EACO-E2CUP65-00
DATE	May 20, 2006

FOR : _____

KYOCERA INSPECTION STANDARD

TYPE : KCG057QVLDG-G00

KYOCERA CORPORATION
KAGOSHIMA HAYATO PLANT
LCD DIVISION

Original	Designed by :Engineering Dept.			Confirmed by :QA Dept.	
Issue Date	Prepared	Checked	Approved	Checked	Approved
May 20, 2006	<i>H. Nishino</i>	<i>Y. Yamaguchi</i>	<i>M. Fujitani</i>	<i>26. 1st</i>	<i>T. Minami</i>

Revision Record

Date	Designed by: Engineering Dept.			Confirmed by: QA Dept.	
	Prepared	Checked	Approved	Checked	Approved
Rev. No.	Date	Page	Descriptions		

Visuals specification

1)Note

Item	Note
General	<p>1. When defects specified in this Inspection Standards are inspected, operating voltage(Vop) shall be set at the level where optimized contrast is available. Display quality is applied up to effective viewing area. (Bi-Level INSPECTION)</p> <p>2. This inspection standard about the image quality shall be applied to any defect within the effective viewing area and shall not be applicable to outside of the area.</p> <p>3. Should any defects which are not specified in this standard happen, additional standard shall be determined by mutual agreement between customer and Kyocera.</p> <p>4. Inspection conditions</p> <p>Luminance : 500 Lux minimum . Inspection distance : 300 mm (from the sample) Temperature : 25 ± 5 °C Direction : right above</p>
Definition of Inspection item	<p>Pinhole, Bright spot Black spot, Scratch Foreign particle</p> <p>The color of a small area is different from the remainder. The phenomenon does not change with voltage.</p>
	<p>Contrast variation</p> <p>The color of a small area is different from the remainder. The phenomenon changes with voltage.</p>
	<p>Polarizer (Scratch, Bubble, Dent)</p> <p>Scratch, Bubble and Dent in the polarizer which can be observed in on / off state.</p>

2) Standard

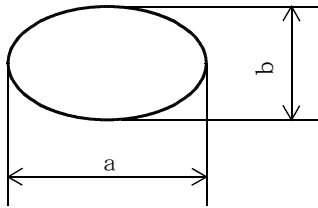
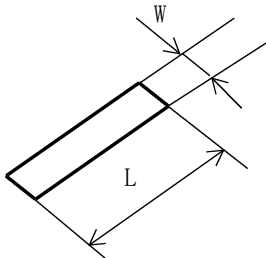
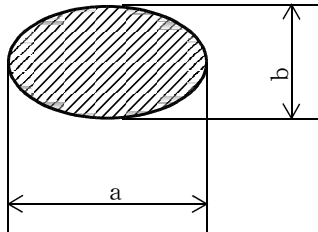
Inspection item	Judgement standard																						
Pinhole, Bright spot Black spot, Foreign particle	<div style="text-align: center;">  $d = (a + b) / 2$ <table border="1" data-bbox="587 566 1393 801"> <thead> <tr> <th>Category</th> <th>Size (mm)</th> <th>Acceptable number</th> </tr> </thead> <tbody> <tr> <td>A</td> <td>$d \leq 0.2$</td> <td>neglected</td> </tr> <tr> <td>B</td> <td>$0.2 < d \leq 0.3$</td> <td>5</td> </tr> <tr> <td>C</td> <td>$0.3 < d \leq 0.5$</td> <td>3</td> </tr> <tr> <td>D</td> <td>$0.5 < d$</td> <td>0</td> </tr> </tbody> </table> </div>	Category	Size (mm)	Acceptable number	A	$d \leq 0.2$	neglected	B	$0.2 < d \leq 0.3$	5	C	$0.3 < d \leq 0.5$	3	D	$0.5 < d$	0							
Category	Size (mm)	Acceptable number																					
A	$d \leq 0.2$	neglected																					
B	$0.2 < d \leq 0.3$	5																					
C	$0.3 < d \leq 0.5$	3																					
D	$0.5 < d$	0																					
Scratch, Foreign particle	<div style="text-align: center;">  <table border="1" data-bbox="557 1171 1422 1473"> <thead> <tr> <th></th> <th>Width (mm)</th> <th>Length (mm)</th> <th>Acceptable No.</th> </tr> </thead> <tbody> <tr> <td>A</td> <td>$W \leq 0.03$</td> <td>—</td> <td>neglected</td> </tr> <tr> <td>B</td> <td rowspan="3">$0.03 < W \leq 0.1$</td> <td>$L \leq 2.0$</td> <td>neglected</td> </tr> <tr> <td>C</td> <td>$2.0 < L \leq 4.0$</td> <td>3</td> </tr> <tr> <td>D</td> <td>$4.0 < L$</td> <td>0</td> </tr> <tr> <td>E</td> <td>$0.1 < W$</td> <td>—</td> <td>According to Circular</td> </tr> </tbody> </table> </div>		Width (mm)	Length (mm)	Acceptable No.	A	$W \leq 0.03$	—	neglected	B	$0.03 < W \leq 0.1$	$L \leq 2.0$	neglected	C	$2.0 < L \leq 4.0$	3	D	$4.0 < L$	0	E	$0.1 < W$	—	According to Circular
	Width (mm)	Length (mm)	Acceptable No.																				
A	$W \leq 0.03$	—	neglected																				
B	$0.03 < W \leq 0.1$	$L \leq 2.0$	neglected																				
C		$2.0 < L \leq 4.0$	3																				
D		$4.0 < L$	0																				
E	$0.1 < W$	—	According to Circular																				
Contrast variation	<div style="text-align: center;">  $d = (a + b) / 2$ <table border="1" data-bbox="587 1821 1393 2007"> <thead> <tr> <th>Category</th> <th>Size (mm)</th> <th>Acceptable number</th> </tr> </thead> <tbody> <tr> <td>A</td> <td>$d \leq 0.5$</td> <td>neglected</td> </tr> <tr> <td>B</td> <td>$0.5 < d \leq 0.7$</td> <td>3</td> </tr> <tr> <td>C</td> <td>$0.7 < d$</td> <td>0</td> </tr> </tbody> </table> </div>	Category	Size (mm)	Acceptable number	A	$d \leq 0.5$	neglected	B	$0.5 < d \leq 0.7$	3	C	$0.7 < d$	0										
Category	Size (mm)	Acceptable number																					
A	$d \leq 0.5$	neglected																					
B	$0.5 < d \leq 0.7$	3																					
C	$0.7 < d$	0																					

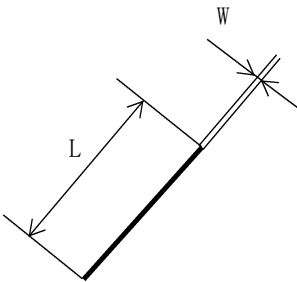
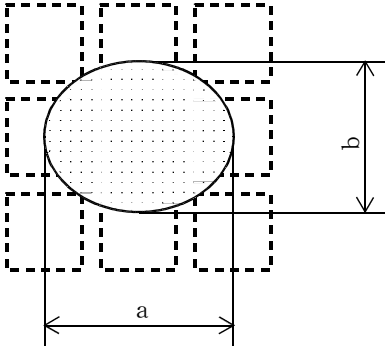
Inspection item	Judgement standard																																		
Polarizer (Scratch, Bubble, Dent)	<p data-bbox="544 248 708 277">(1) Scratch</p> <div data-bbox="804 248 1102 528" style="text-align: center;">  </div> <table border="1" data-bbox="560 689 1422 1021" style="width: 100%; border-collapse: collapse; text-align: center;"> <thead> <tr> <th></th> <th>Width (mm)</th> <th>Length (mm)</th> <th>Acceptable No.</th> </tr> </thead> <tbody> <tr> <td>A</td> <td>$W \leq 0.1$</td> <td>—</td> <td>neglected</td> </tr> <tr> <td>B</td> <td rowspan="2">$0.1 < W \leq 0.3$</td> <td>$L \leq 5.0$</td> <td>neglected</td> </tr> <tr> <td>C</td> <td>$5.0 < L$</td> <td>0</td> </tr> <tr> <td>D</td> <td>$0.3 < W$</td> <td>—</td> <td>0</td> </tr> </tbody> </table> <p data-bbox="544 1070 807 1099">(2)Bubble (dent)</p> <div data-bbox="847 1240 1235 1585" style="text-align: center;">  </div> <table border="1" data-bbox="587 1677 1394 2009" style="width: 100%; border-collapse: collapse; text-align: center;"> <thead> <tr> <th>Category</th> <th>Size (mm)</th> <th>Acceptable number</th> </tr> </thead> <tbody> <tr> <td>A</td> <td>$d \leq 0.2$</td> <td>neglected</td> </tr> <tr> <td>B</td> <td>$0.2 < d \leq 0.3$</td> <td>5</td> </tr> <tr> <td>C</td> <td>$0.3 < d \leq 0.5$</td> <td>3</td> </tr> <tr> <td>D</td> <td>$0.5 < d$</td> <td>0</td> </tr> </tbody> </table>		Width (mm)	Length (mm)	Acceptable No.	A	$W \leq 0.1$	—	neglected	B	$0.1 < W \leq 0.3$	$L \leq 5.0$	neglected	C	$5.0 < L$	0	D	$0.3 < W$	—	0	Category	Size (mm)	Acceptable number	A	$d \leq 0.2$	neglected	B	$0.2 < d \leq 0.3$	5	C	$0.3 < d \leq 0.5$	3	D	$0.5 < d$	0
	Width (mm)	Length (mm)	Acceptable No.																																
A	$W \leq 0.1$	—	neglected																																
B	$0.1 < W \leq 0.3$	$L \leq 5.0$	neglected																																
C		$5.0 < L$	0																																
D	$0.3 < W$	—	0																																
Category	Size (mm)	Acceptable number																																	
A	$d \leq 0.2$	neglected																																	
B	$0.2 < d \leq 0.3$	5																																	
C	$0.3 < d \leq 0.5$	3																																	
D	$0.5 < d$	0																																	