



SmarterGlass

state-of-the-art display solutions

www.smarterglass.com
978 997 4104
sales@smarterglass.com

SPEC. NO.	TQ3C-8EAC0-E1CYE09-01
DATE	November 1, 2004

S P E C

FOR : _____

TYPE : KCS077VG2EA-G43

CONTENTS

1. Application
2. Construction and Outline
3. Mechanical Specifications
4. Absolute Maximum Ratings
5. Electrical Characteristics
6. Optical Characteristics
7. Circuit Block Diagram
8. Interface Signals
9. Interface Timing Chart
10. Data and Screen
11. Input Timing Characteristics
12. Supply Voltage Sequence Condition
13. Backlight Characteristics
14. Lot Number Identification
15. Warranty
16. Precaution for Use
17. Reliability Data / Environmental Test
18. Outline Drawing

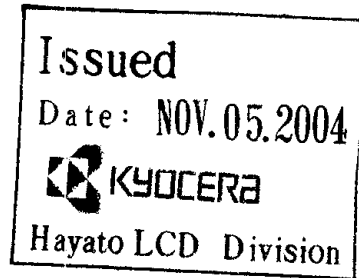

KYOCERA CORPORATION
KAGOSHIMA HAYATO PLANT
LCD DIVISION

This specification is subject to change without notice.
Consult Kyocera before ordering

Original	Designed by :Engineering Dept.			Confirmed by :QA Dept.	
Issue Data	Prepared	Checked	Approved	Checked	Approved
August 2, 2002	<i>T. Onodera</i>	<i>M. Fujitani</i>	<i>H. Ohno</i>	<i>Y. Yoshida</i>	<i>Y. Matsumoto</i>

Caution

1. This Kyocera LCD module has been specifically designed for use only in electronic devices in the areas of audio control, office automation, industrial control, home appliances, etc. The modules should not be used in medical applications where module failure could result in physical harm or loss of life, and Kyocera expressly disclaims any and all liability relating in any way to the use of the module in such medical applications.
2. Customer agrees to indemnify, defend and hold Kyocera harmless from and against any and all actions, claims, losses, damages, liabilities, awards, costs, and expenses, including legal fees, resulting from or arising out of Customer's use, or sale for use, of Kyocera modules in medical applications.
3. Kyocera shall have the right, which Customer hereby acknowledges, to immediately scrap or destroy tooling for Kyocera modules for which no Purchase Orders have been received from the Customer in a two-year period.

Revision Record

Date		Designed by: Engineering Dept.			Confirmed by: QA Dept.	
		Prepared	Checked	Approved	Checked	Approved
Nov. 1, 2004		T. Onodera	M. Fujitani	H. Ohno	Y. Yoshida	Y. Matsumoto
Rev. No.	Date	Page	Descriptions			
01	Nov. 1, 2004	1	2. Construction and Outline ~Change Inverter "KCI-13" → "KCI-15"			
		3	4-2. Environmental absolute maximum ratings ~Add comment "*2 (Please refers to)"			
		4	5. Electrical characteristics *3 Display high frequency pattern. ~Add "Temp. = 25°C"			
		10	8-2. CFL ~Change SYMBOL "HV→HOT", "GND→COLD" ~Delete "LEVEL"			
		13	11. Input Timing Characteristics ~Change "FRM"			
		17	14. Lot Number Identification ~Change "YEAR" "2002~2007" → "2004~2009" ~Change "CODE" "2~7" → "4~9"			
		18	16-1. Installation of the LCD ~Add comment "8. This Kyocera LCD"			
			16-3. LCD Operation ~Change comment "2. Adjust "LCD" driving"			
			16-4. Storage ~Change comment "2. Always store the"			

1. Application

This data sheet defines the specification for a $(640 \times R.G.B) \times 480$ dot, STN Transmissive color dot matrix type Liquid Crystal Display with CFL backlight.

2. Construction and Outline

$(640 \times R.G.B) \times 480$ dots, COB type LCD with CFL backlight.

Backlight system : Side-edge type CFL (2 tubes).

Inverter : Option
Recommended Inverter : KCI-15 (MINEBEA ELECTRONICS)
or equivalent

Polarizer : Glare treatment.

Additional circuit : Bias voltage circuit, Randomizing circuit.

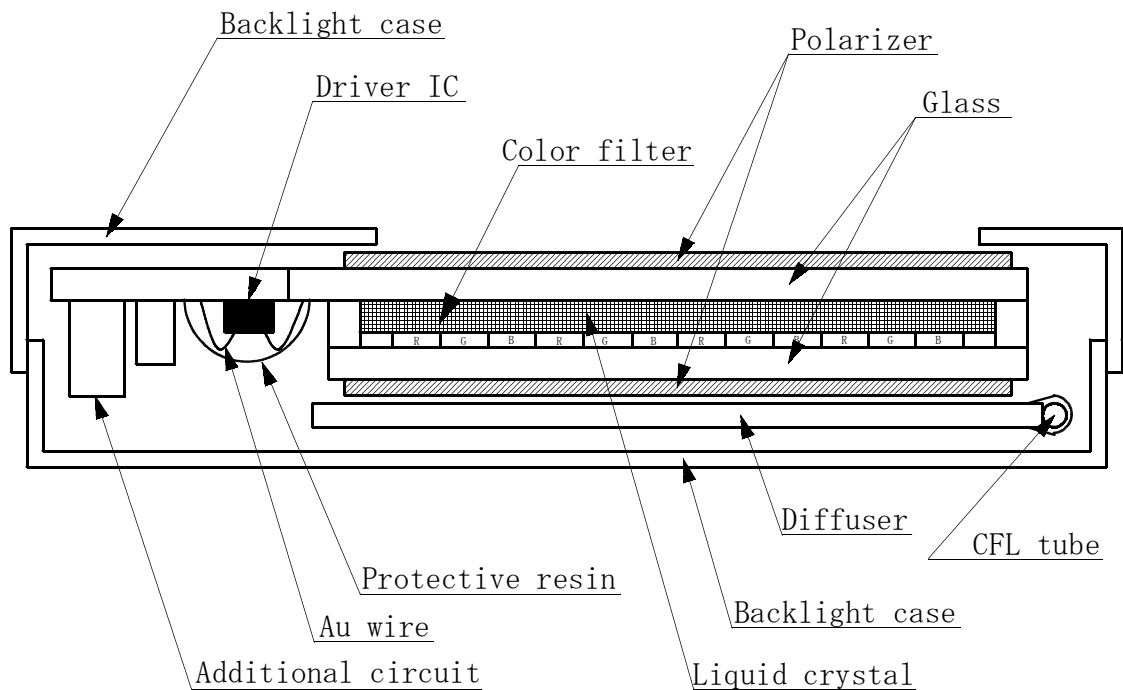

This drawing is showing conception only.

3. Mechanical Specifications

ITEM	SPECIFICATION	UNIT
Outline dimensions	199.0 (W) × 147.0 (H) × 10.0 (D)	mm
Effective viewing area	160.42 (W) × 121.06 (H)	mm
Dot number	(640×R.G.B) (W) × 480 (H)	Dots
Dot size	0.062 (W) × 0.226 (H)	mm
Dot pitch	0.082 (W) × 0.246 (H)	mm
Display color *1	White *2	—
Base color *1	Black *2	—
Mass	330	g

*1 Due to the characteristics of the LC material, the color vary with environmental temperature.

*2 Negative-type display
 Display data "H" :R.G.B Dots ON : White
 Display data "L" :R.G.B Dots OFF : Black

4. Absolute Maximum Ratings

4-1. Electrical absolute maximum ratings

ITEM	SYMBOL	MIN.	MAX.	UNIT
Supply voltage for logic	VDD	0	7.0	V
Supply voltage for LCD driving	VEE	0	36.0	V
Input signal voltage *1	Vin	0	VDD	V

*1 Input signal : CP, LOAD, FRM, DISP, HD0~HD7, LD0~LD7

4-2. Environmental absolute maximum ratings

ITEM	SYMBOL	MIN	MAX	UNIT
Operating temperature *1	Top	0	50	°C
Storage temperature *2	T _{STO}	-20	60	°C
Operating humidity *3	H _{OP}	10	*4	%RH
Storage humidity *3	H _{STO}	10	*4	%RH
Vibration	—	*5	*5	—
Shock	—	*6	*6	—

*1 LCD's display quality shall not be guaranteed at the temperature range of : below 0°C and upper 40°C

*2 Temp. = -20°C < 48 h , Temp = 60°C < 168 h

Store LCD panel at normal temperature/humidity. Keep it free from vibration and shock.

LCD panel that is kept at low or high temperature for a long time can be defective due to the other condition, even if the temperature satisfies standard.

(Please refers to 16. Precautions for use.)

*3 Non-condensation.

*4 Temp. ≤ 40°C, 85% RH Max.

Temp. > 40°C, Absolute Humidity shall be less than 85%RH at 40°C.

*5

Frequency	10~55 Hz	Converted to acceleration value : (0.3~9 m/s ²)
Vibration width	0.15 mm	
Interval	10-55-10 Hz 1 minute	

2 hours in each direction X/Y/Z (6 hours as total)

EIAJ ED-2531.

*6 Acceleration: 490 m/s²

Pulse width : 11 ms

3 times in each direction : ±X/±Y/±Z.

EIAJ ED-2531.

5. Electrical Characteristics

VDD = +5.0V ± 5%, Temp. = 0~50°C

ITEM	SYMBOL	CONDITION	MIN.	TYP.	MAX.	UNIT
Supply voltage for logic	VDD	—	4.75	5.00	5.25	V
Supply voltage for LCD driving	VEE	—	32.0	34.0	36.0	V
LCD driving voltage *1	Vop = VCONT	0 °C	26.1	27.1	28.1	V
		25 °C	25.1	26.1	27.1	V
		40 °C	24.5	25.5	26.5	V
Input voltage	Vin	"H" level	0.8VDD	—	VDD	V
		"L" level	0	—	0.2VDD	V
Clock frequency	f _{cp}	—	4.03	4.32	16.0	MHz
Frame frequency *2	f _{FRM}	—	70	75	—	Hz
Current consumption for logic	IDD	*3	—	3.2	4.8	mA
Current consumption for LCD driving	IEE		—	11.5	17.3	mA
Power consumption	Pdisp		—	316	493	mW

*1 Maximum contrast ratio is obtained by adjusting the LCD supply voltage (Vop= VCONT) for driving LCD.

*2 In consideration of display quality, it is recommended that frame frequency is set in the range of 70~80Hz. When you have to use higher frame and clock frequencies, confirm the LCD's performance and quality prior to finalizing the frequency values: Generally, as frame and clock frequencies become higher, current consumption will get bigger and display quality will be degraded.

*3 Display high frequency pattern, (see below).
 VDD = 5.0V , Vop = VCONT , f_{FRM} = 75 Hz , f_{cp} = 4.32MHz, Temp. = 25°C
 Pattern:

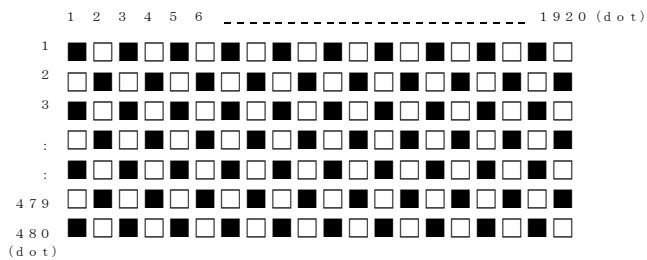

6. Optical Characteristics

Temp. = 25°C, Measuring spot = ϕ 6mm

ITEM		SYMBOL	CONDITION		MIN.	TYP.	MAX.	UNIT
Response time	Rise	Tr	$\theta = \phi = 0^\circ$		—	160	260	ms
	Down	Td	$\theta = \phi = 0^\circ$		—	140	240	ms
Viewing angle range		θ	CR \geq 2	$\phi = 0^\circ$	-30	—	40	deg.
		ϕ		$\theta = 0^\circ$	-50	—	50	deg.
Contrast ratio		CR	$\theta = \phi = 0^\circ$		15	25	—	—
Brightness		L	IL=5.0mA \times 2		150	200	—	cd/m ²
Chromaticity coordinates	Red	x	$\theta = \phi = 0^\circ$		0.51	0.56	0.61	—
		y			0.29	0.34	0.39	
	Green	x	$\theta = \phi = 0^\circ$		0.25	0.30	0.35	
		y			0.49	0.54	0.59	
	Blue	x	$\theta = \phi = 0^\circ$		0.11	0.16	0.21	
		y			0.11	0.16	0.21	
	White	x	$\theta = \phi = 0^\circ$		0.27	0.32	0.37	
		y			0.31	0.36	0.41	
	Black	x	$\theta = \phi = 0^\circ$		0.24	0.29	0.34	
		y			0.24	0.29	0.34	

Optimum contrast is obtained by adjusting the LCD driving voltage (Vop) while at the viewing angle of $\theta = \phi = 0^\circ$.

6-1. Contrast ratio is defined as follows:

$$CR = \frac{\text{Brightness at all pixels "White"}}{\text{Brightness at all pixels "Black"}}$$

6-2. Definition of viewing angle

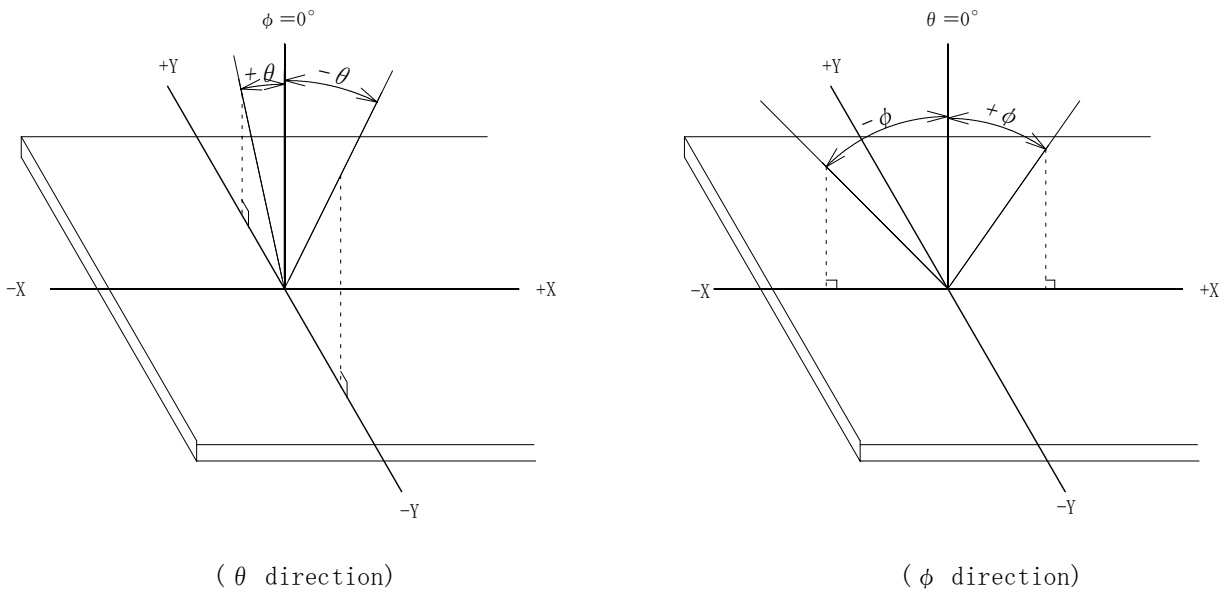

6-3. Definition of response time

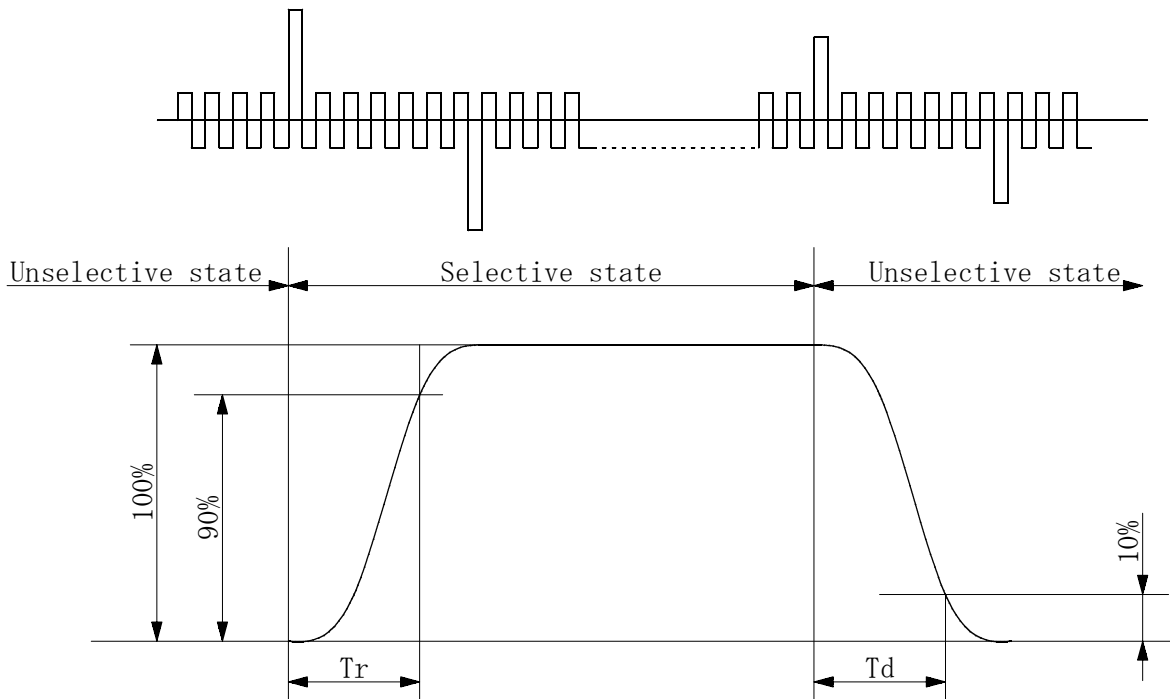

6-4. Definition of Vop

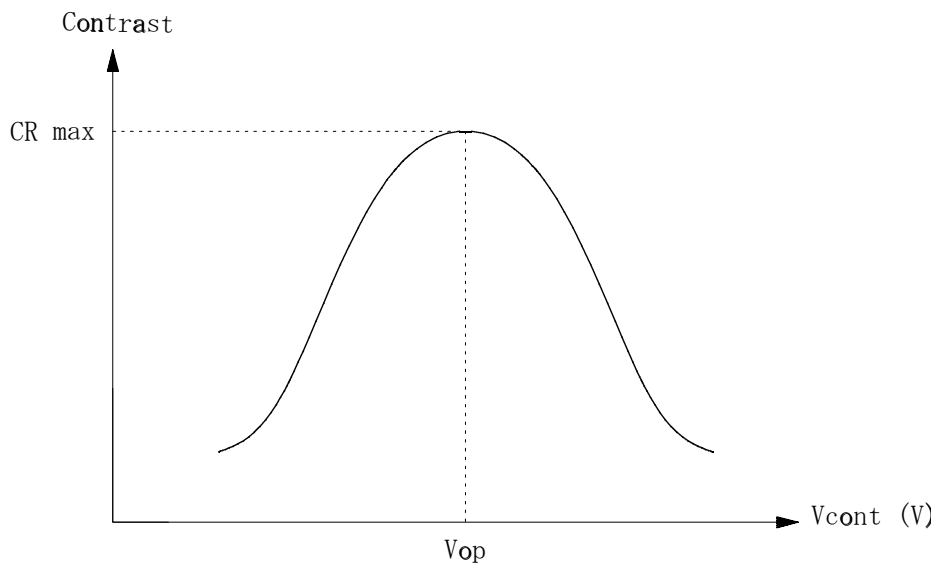

6-5. Measuring points

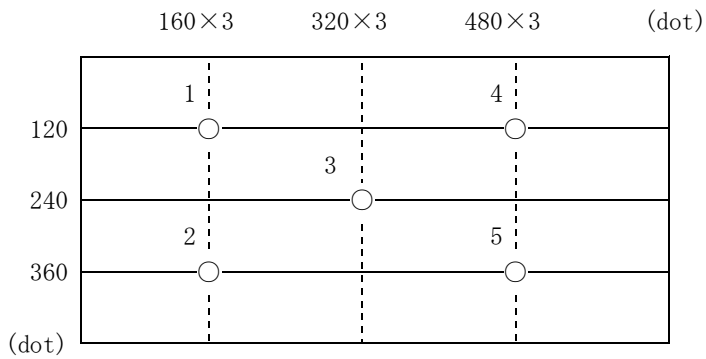

- 1) Rating is defined as the average brightness inside the viewing area.
- 2) 30 minutes after CFL is turned on. (Ambient Temp. =25°C)
- 3) The inverter should meet the eccentric conditions;
 - Sine, symmetric waveform without spike in positive and negative.
- 4) Measuring inverter : KCI-15 (MINEBEA ELECTRONICS)

7. Circuit Block Diagram

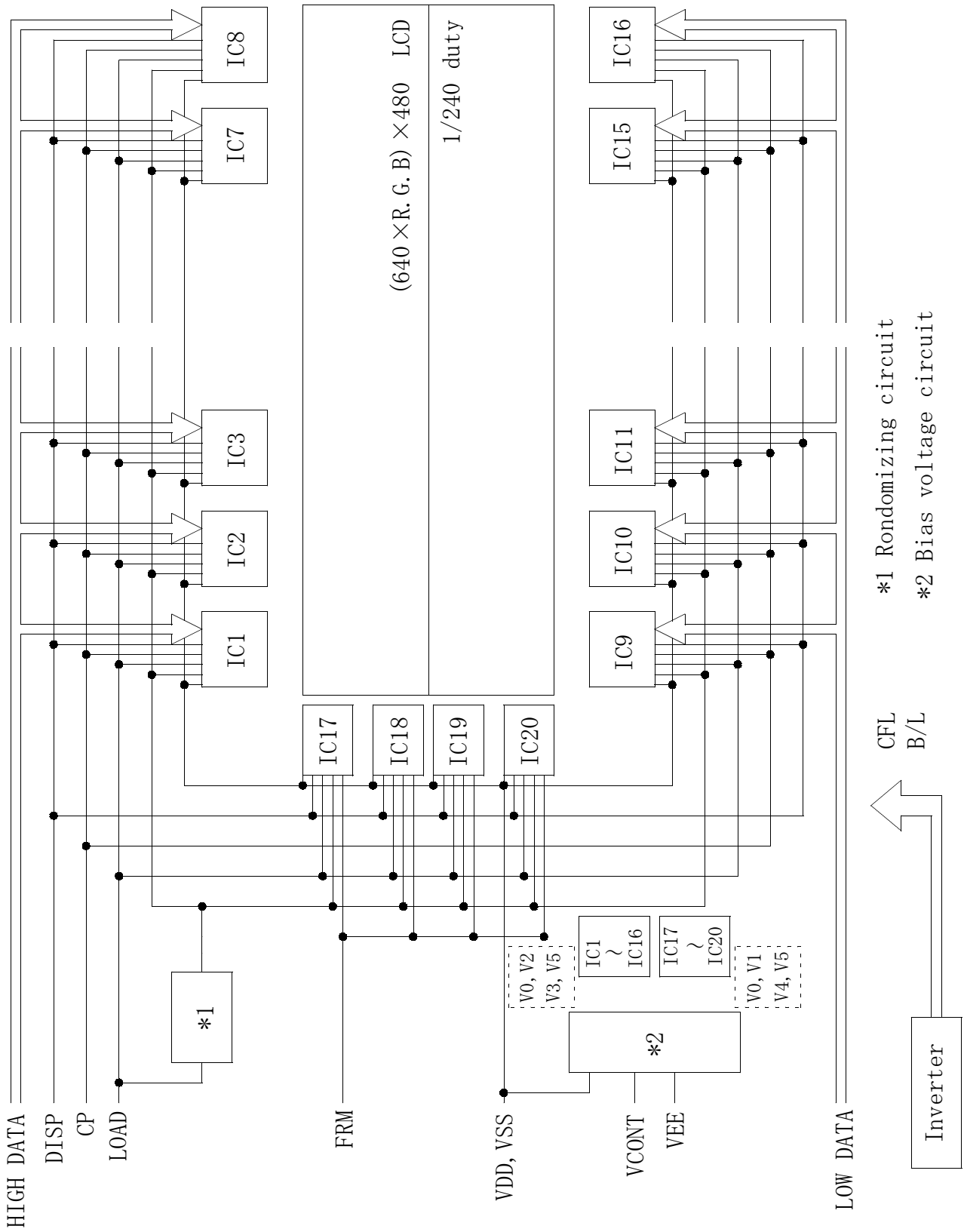

7-1. Power Supply

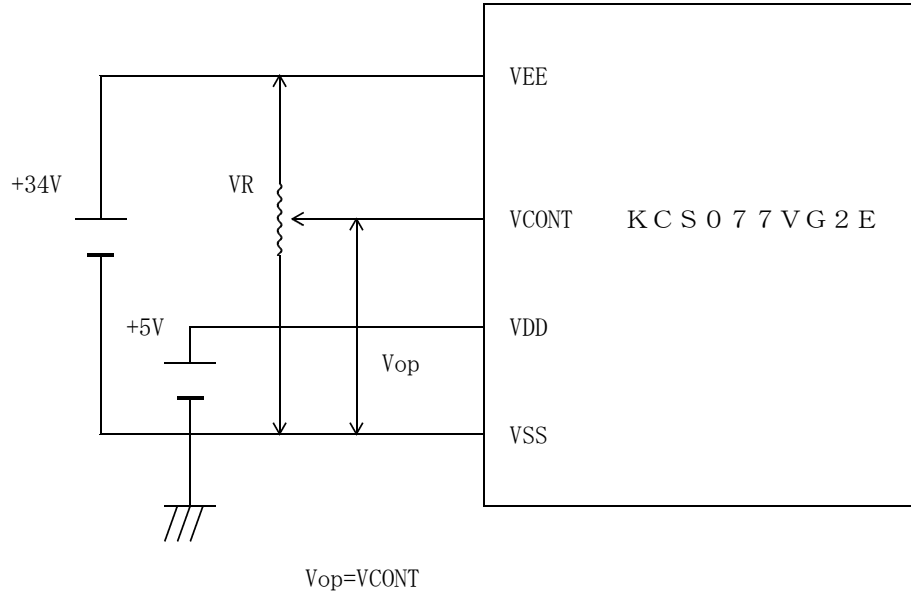

8. Interface Signals

8-1. LCD

CN1 : 53261-1510 (Molex)

PIN NO.	SYMBOL	DESCRIPTION	LEVEL
1	FRM	Synchronous signal for driving scanning line	H
2	NC	No connect	—
3	DISP	Display control signal	H(ON), L(OFF)
4	LOAD	Data signal latch clock	H → L
5	VSS	GND	—
6	CP	Data signal shift clock	H → L
7	VSS	GND	—
8	HD0	Display data (Upper column)	H(ON), L(OFF)
9	HD1		
10	HD2		
11	HD3		
12	HD4		
13	HD5		
14	HD6		
15	HD7		

Recommended matching connector : 51021-1500 (Molex)

CN2 : 53261-1410 (Molex)

PIN No	SYMBOL	DESCRIPTION	LEVEL
1	LD0	Display data (Lower column)	H(ON), L(OFF)
2	LD1		
3	LD2		
4	LD3		
5	LD4		
6	LD5		
7	LD6		
8	LD7		
9	VDD	Power supply for logic	—
10	VSS	GND	—
11	NC	No connect	—
12	VEE	Power supply for LCD	—
13	VEE	Power supply for LCD	—
14	VCONT	LCD adjust voltage	—

Recommended matching connector : 51021-1400 (Molex)

8-2. CFL

CN3 : QZ-19-3F01 (HONDA) × 2

PIN NO.	SYMBOL	DESCRIPTION
1	COLD	Inverter output low voltage side
2	NC	—
3	HOT	Inverter output high voltage side

Recommended matching connector : QZ-19-A3MYL#02 (HONDA) × 2

9. Interface Timing Chart

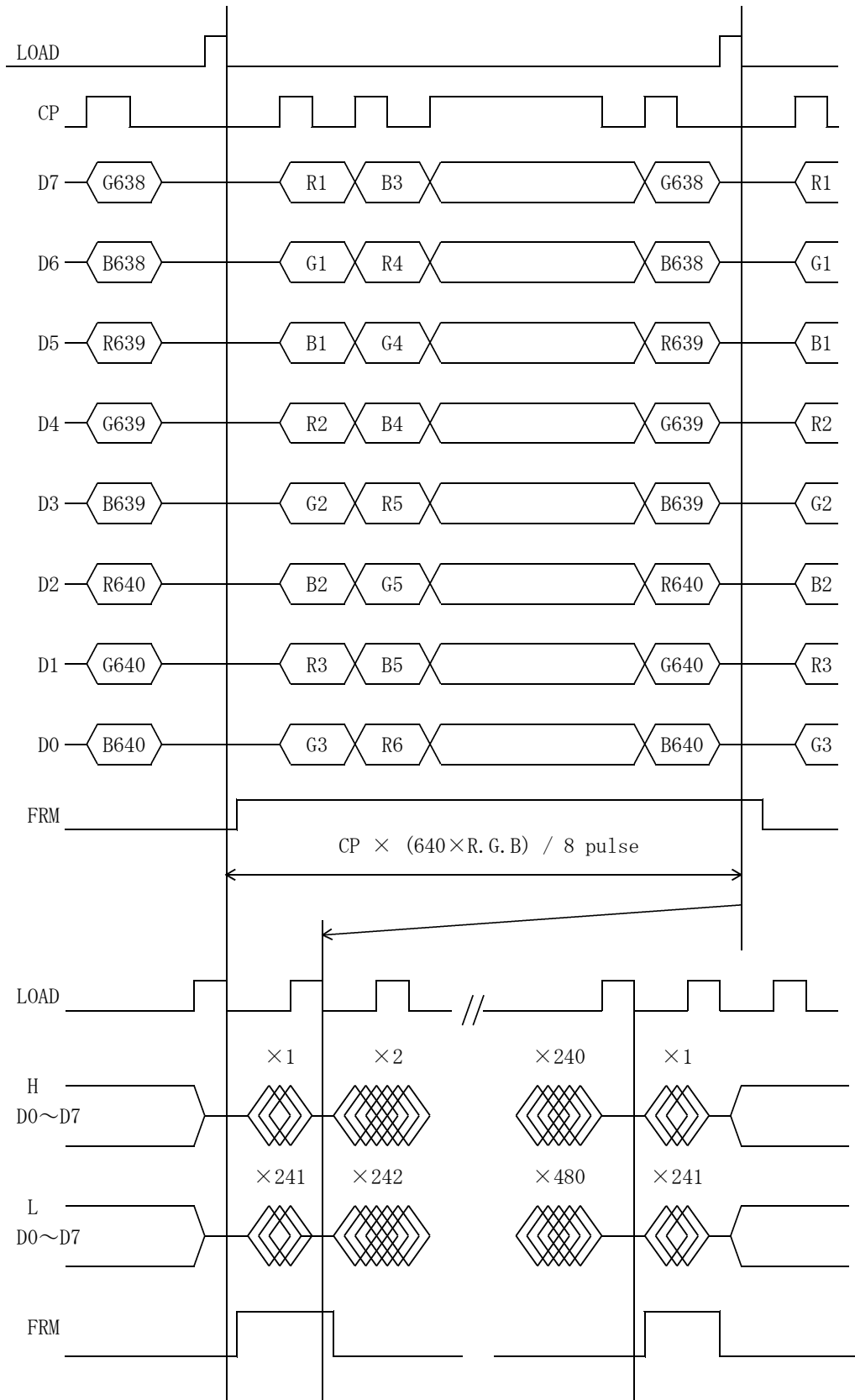

* The cycle of load signal should be stable and continuously applied without interruption.

* The above-mentioned timing chart shows a reference to set up a LCD module, not an electrical rating.

1 0 . Data and Screen

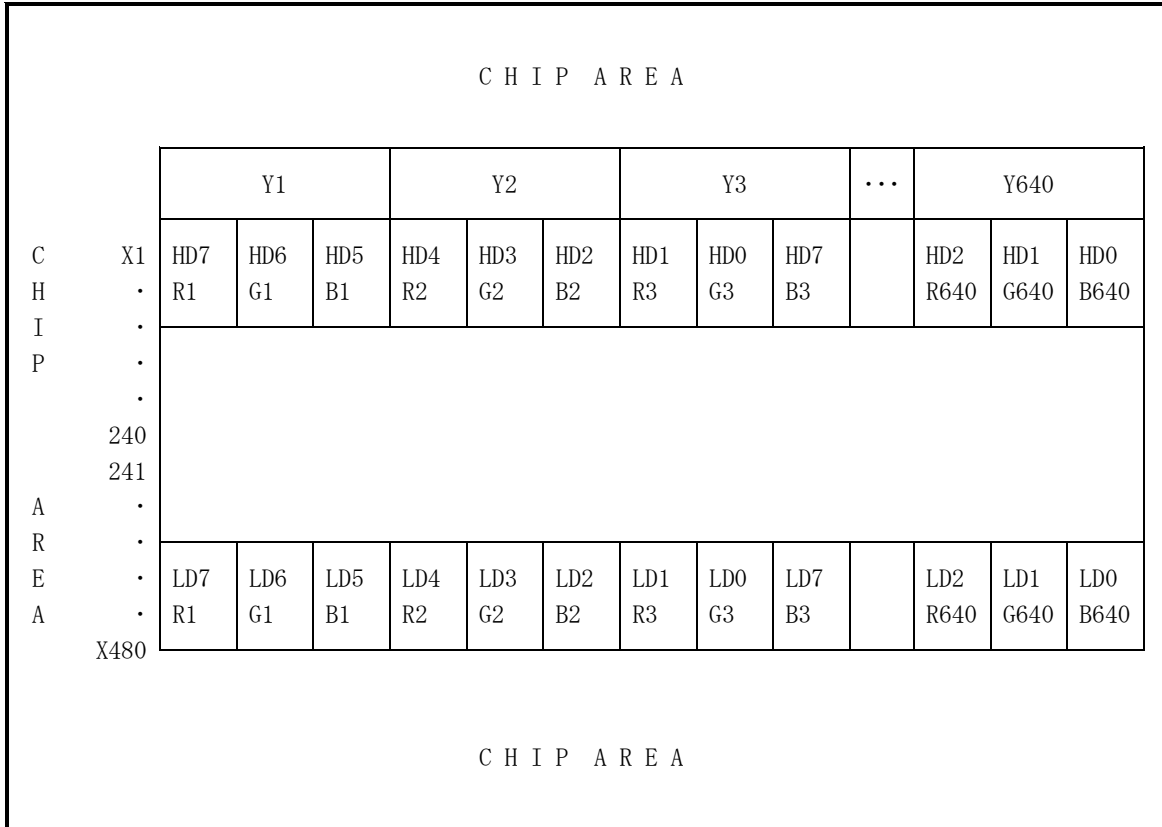

1 1. Input Timing Characteristics

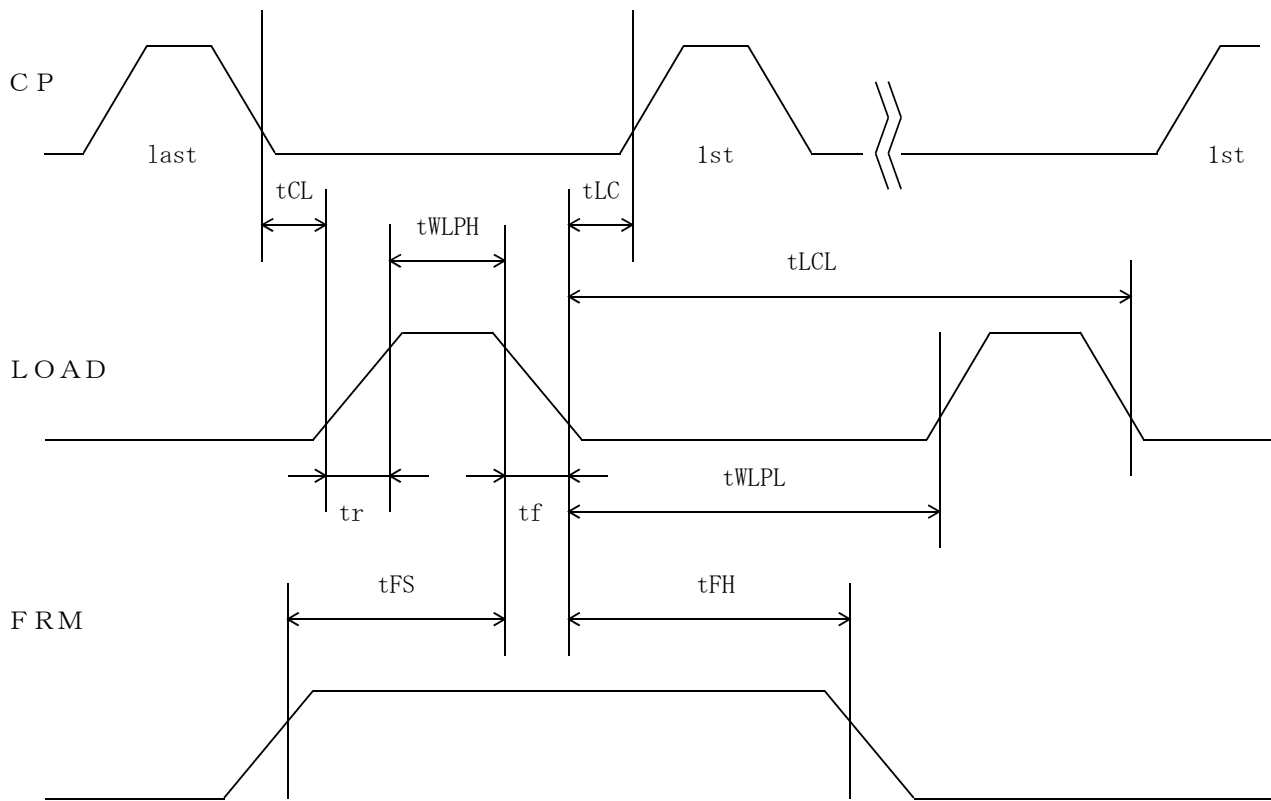
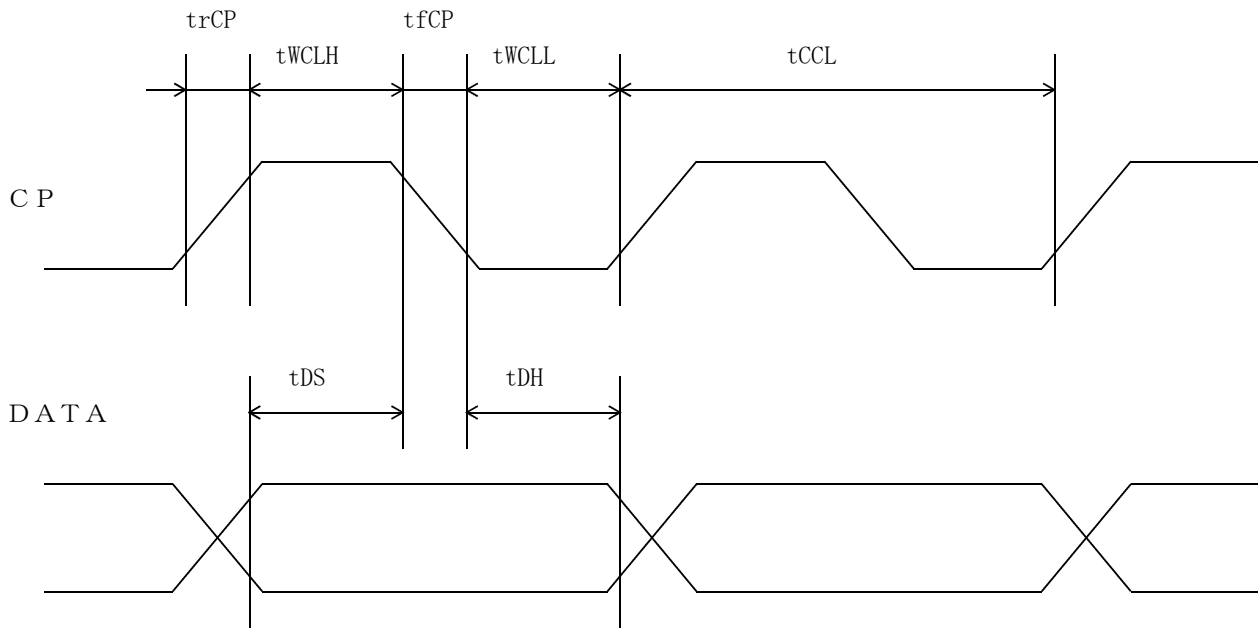

11-1. Switching characteristics

Input characteristics ; VDD = +5.0V ± 5%

Temp. = 25°C

ITEM	SYMBOL	MIN.	MAX.	UNIT
CP Cycle *1, *2	tCCL	62	—	ns
CP "H" Pulse Width *2	tWCLH	25	—	ns
CP "L" Pulse Width *2	tWCLL	25	—	ns
CP Rise Up Time *2	trCP	—	30	ns
CP Fall Down Time *2	tfCP	—	30	ns
Data Set Up Time	tDS	25	—	ns
Data Hold Time	tDH	20	—	ns
Load "H" Pulse Width	tWLPH	50	—	ns
Load "L" Pulse Width	tWLPL	370	—	ns
LOAD Cycle *3	tLCL	420	—	ns
CP → LOAD Delay Time	tCL	0	—	ns
LOAD → CP Delay Time *4	tLC	120-tWLPH	—	ns
Input Signal Rise Up Time	tr	—	30	ns
Input Signal Fall Down Time	tf	—	30	ns
FRM Data Set Up Time	tFS	100	—	ns
FRM Data Hold Time	tFH	30	—	ns

*1 CP Cycle is adjust so that FRM signal is 75Hz.

*2 The formula of condition

$$\textcircled{1} \quad trCP + tfCP \leq tCCL - (tWCLH + tWCLL)$$

$$\textcircled{2} \quad trCP, tfCP \leq 30 \text{ ns}$$

Please use on condition that ①, ② are filled.

*3 LOAD cycle is const.

*4 tLC ≥ 0

1 2. Supply Voltage Sequence Condition

DO NOT apply DC voltage to the LCD panel.

DC voltage induce irreversible electrochemical reactions and reduce LCD life.

Always follow the power supply ON/OFF sequence of VDD first, input signal second, VCONT third and finally DISP. This will prevent DC driving of the LCD or CMOS LSI latch up as shown below.

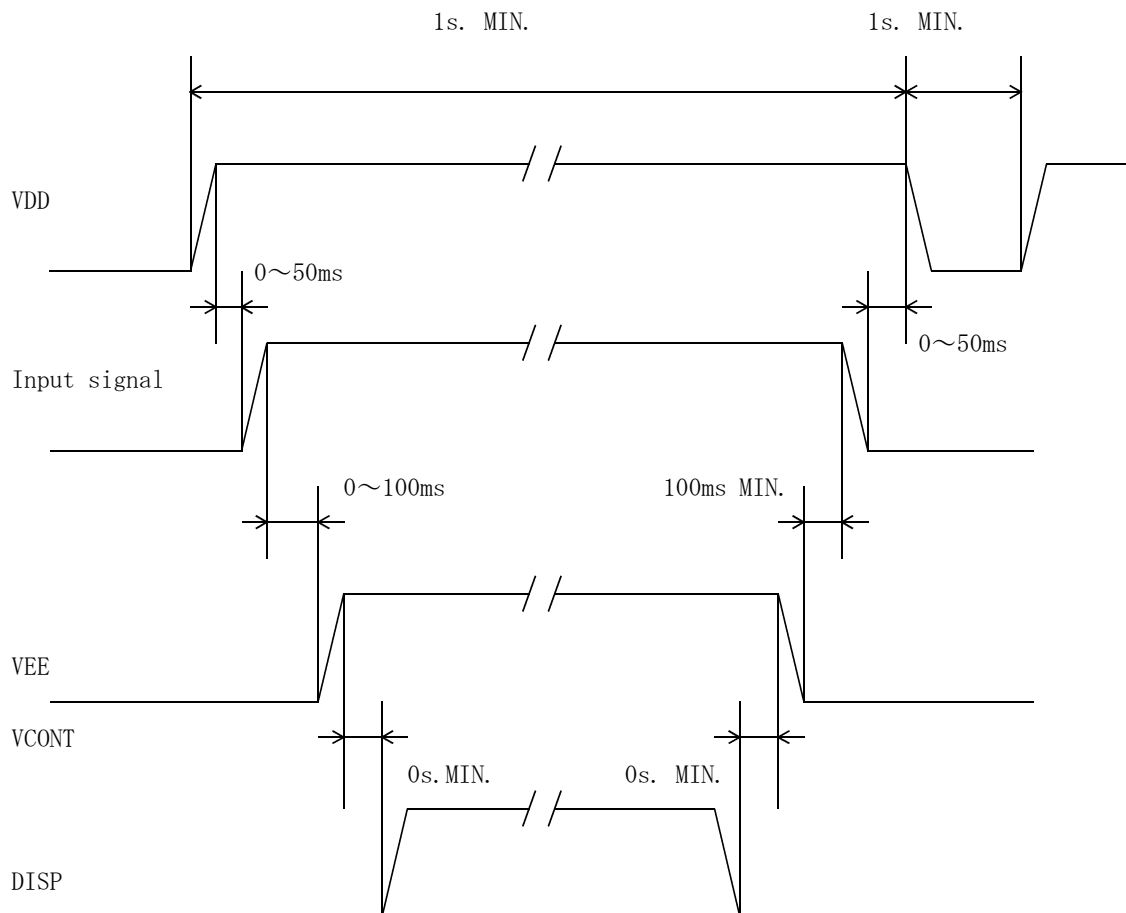

* Input signal : CP, LOAD, FRM, HD0~HD7, LD0~LD7

* The above sequence should be designed as to keep each normal figure on condition that liquid crystal module is loaded on your system.

* Control the input signal and VEE to the above ON-OFF timing when you switch ON/OFF the display during VDD and DISP are on. And also design the circuit as VEE's OFF level become GND level.

* Control the supply voltage sequence not to float all signal line when the LCD panel is driving.

1 3. Backlight Characteristics

CFL ratings

Temp. = 25°C

ITEM	SYMBOL	MIN.	TYP.	MAX.	NOTE
Starting Discharge Voltage *1	VS	—	—	980 Vrms.	0 °C
		—	—	655 Vrms.	25 °C
Discharging tube current *2,*3	IL	2.0 mArms.	5.0 mArms.	6.0 mArms.	—
Discharging tube voltage	VL	—	400 Vrms.	—	—
Operating life (IL=5.0 mArms.) *4	T	25,000 h	40,000 h	—	—
Operating frequency	F	40 kHz	—	100 kHz	—

*1 The Non-load output voltage (VS) of the inverter should be designed to have some margin, because VS may increase due to the leak current which may be caused by wiring of CFL cables. (Reference value : 1280 Vrms MIN.)

*2 We recommend that you should set the discharging tube current at lower than typical value so as to prevent the heat accumulation of CFL tube from deteriorating a performance of the LCD.

*3 Do not apply more than 6.0 mA discharging tube current. Because CFL maybe broken due to over current.

*4 When the illuminance or quantity of light has decreased to 50 % of the initial value. Average life time of CFL will be decreased when LCD is operating at lower and higher temperature.

1 4. Lot Number Identification

The lot number shall be indicated on the back of the backlight case of each LCD.

K C S 0 7 7 V G 2 E A - G 4 3 - -

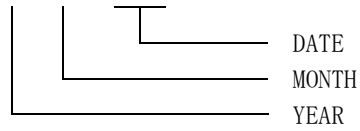

YEAR	2004	2005	2006	2007	2008	2009
CODE	4	5	6	7	8	9

MONTH	JAN.	FEB.	MAR.	APR.	MAY	JUN.
CODE	1	2	3	4	5	6

MONTH	JUL.	AUG.	SEP.	OCT.	NOV.	DEC.
CODE	7	8	9	X	Y	Z

1 5. Warranty

15-1. Incoming inspection

Please inspect the LCD within one month after your receipt.

15-2. Production Warranty

Kyocera warrants its LCDs for a period of 12 months after receipt by the purchaser, and within the limits specified. Kyocera shall, by mutual agreement, replace or rework defective LCDs that are shown to be Kyocera's responsibility.

16. Precautions for use

16-1. Installation of the LCD

1. Please ground either of the mounting (screw) holes located at each corner of an LCD module, in order to stabilize brightness and display quality.
2. A transparent protection plate shall be added to protect the LCD and its polarizers.
3. The LCD shall be installed so that there is no pressure on the LSI chips.
4. The LCD shall be installed flat, without twisting or bending.
5. The display window size should be the same as the effective viewing area.
6. In case you use outside frame of effective viewing area as outward appearance of your product, unevenness of its outward appearance is out of guarantee.
7. Do not pull the CFL lead wires and do not bend the root of the wires.
Housing should be designed to protect CFL lead wires from external stress.
8. This Kyocera LCD module has been specifically designed for use in general electronic devices, but not for use in a special environment such as usage in an active gas.
Hence, when the LCD is supposed to be used in a special environment, evaluate the LCD thoroughly beforehand and do not expose the LCD to chemicals such as an active gas.

16-2. Static Electricity

1. Since CMOS ICs are mounted directly onto the LCD glass, protection from static electricity is required. Operation should wear ground straps.

16-3. LCD Operation

1. The LCD shall be operated within the limits specified.
Operation at values outside of these limits may shorten life, and/or harm display images.
2. Adjust "LCD driving voltage" to obtain optimum viewing angle and contrast.
3. Operation of the LCD at temperature below the limit specified may cause image degradation and/or bubbles. It may also change the characteristics of the liquid crystal.
This phenomenon may not recover. The LCD shall be operated within the temperature limits specified.

16-4. Storage

1. The LCD shall be stored within the temperature and humidity limits specified.
Store in a dark area, and protected the LCD from direct sunlight or fluorescent light.
2. Always store the LCD so that it is free from external pressure onto it.

16-5. Screen Surface

1. DO NOT store in a high humidity environment for extended periods.
Image degradation, bubbles, and/or peeling off of polarizers may result.
2. The front polarizer is easily scratched or damaged.
Prevent touching it with any hard material, and from being pushed or rubbed.
3. The LCD screen may be cleaned with a soft cloth or cotton pad. Methanol, or Isopropyl Alcohol may be used, but insure that all solvent residue is removed.
4. Water may cause damage or discoloration of the polarizer.
Clean any condensation or moisture from any source immediately.
5. Always keep the LCD free from condensation during testing.
Condensation may permanently spot or stain the polarizers.

1 7. Reliability Data / Environmental Test

TEST ITEM	TEST CONDITION	TEST TIME	RESULT
High Temp. Atmosphere	70°C	240 h	Display Quality : No defect Display Function : No defect Current Consumption : No defect
Low Temp. Atmosphere	-20°C	240 h	Low Temp. Bubble : None Solid Crystallization of Liquid Crystal : None Display Quality : No defect Display Function : No defect Current Consumption : No defect
High Temp. Humidity Atmosphere	40°C 90%RH	240 h	Display Quality : No defect Display Function : No defect Peel-off of Organic Sealing : None Current Consumption : No defect
Temp. Cycle	-20°C 0.5 h R. T. 0.5 h 70°C 0.5 h	10 cycles	Display Quality : No defect Display Function : No defect Peel-off of Organic Sealing : None Bubble on Cell : None
High Temp. Operation	50°C Vop	500 h	Display Quality : No defect Current Consumption : No defect

* Each test item uses a test LCD only once. The tested LCD is not used in any other tests.

* The LCD is tested in circumstances in which there is no condensation.

* The tested LCD is inspected after 24 hours of storage at room temperature and room humidity after each test is finished.

* The reliability test is not an out-going inspection.

* The results of the reliability test are for your reference purpose only.
The reliability test is conducted only to examine the LCD's capability.

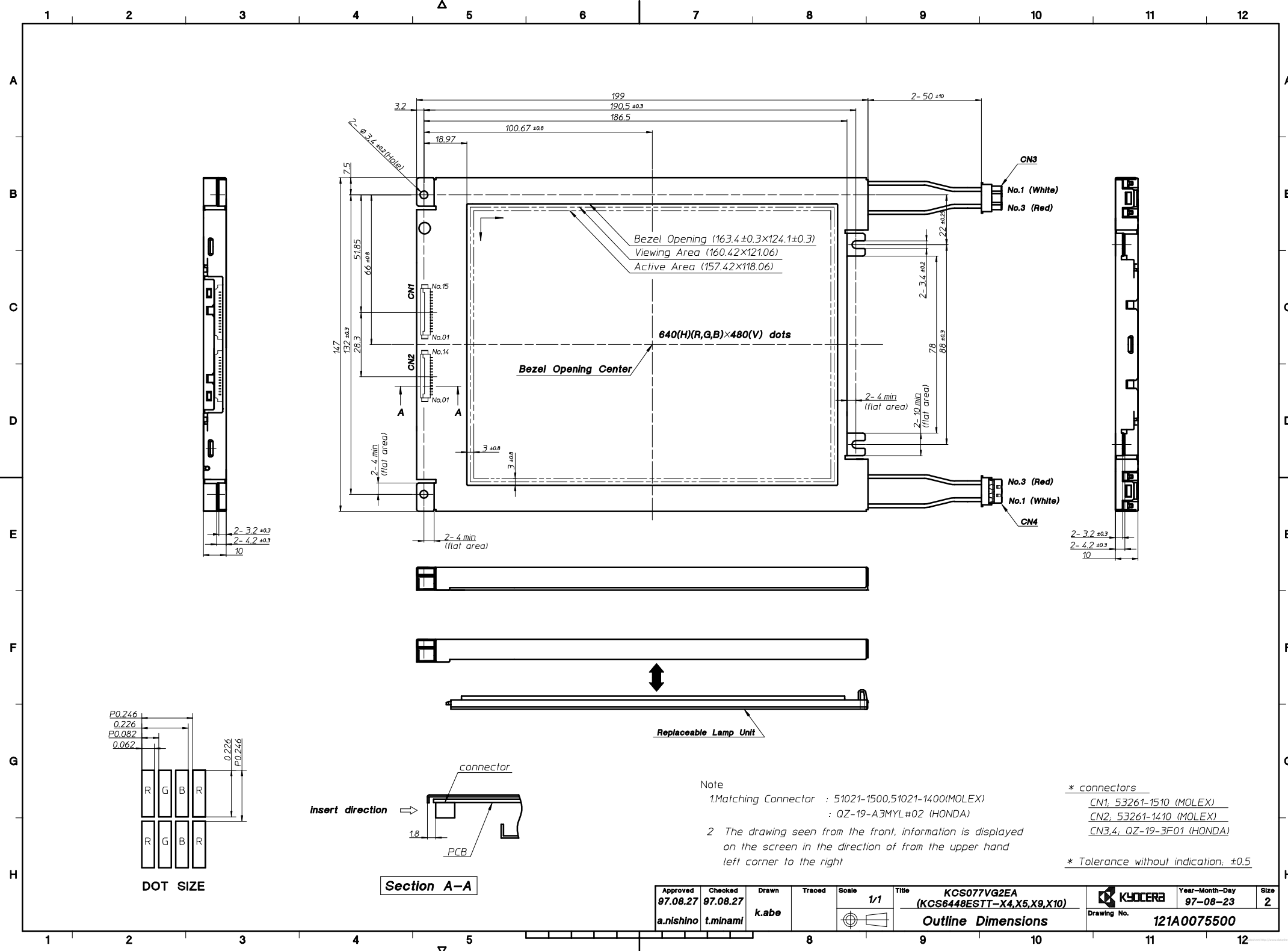

Note

1. Matching Connector : 51021-1500, 51021-1400 (MOLEX)
: QZ-19-A3MYL#02 (HONDA)
2. The drawing seen from the front, information is displayed on the screen in the direction of from the upper hand left corner to the right

* connectors

- CN1, 53261-1510 (MOLEX)
- CN2, 53261-1410 (MOLEX)
- CN3, 4, QZ-19-3F01 (HONDA)

* Tolerance without indication, ±0.5

Approved 97.08.27 a.nishino	Checked 97.08.27 t.minami	Drawn k.abe	Traced	Scale 1/1	Title KCS077VG2EA (KCS6448ESTT-X4,X5,X9,X10) Outline Dimensions	KYOCERA Drawing No. 121A0075500	Year-Month-Day 97-08-23	Size 2
-----------------------------------	---------------------------------	----------------	--------	--------------	--	---------------------------------------	----------------------------	-----------

SPEC. NO.	TQ3C-8EACO-E2CYE10-00
DATE	August 2.2002

FOR : _____

KYOCERA INSPECTION STANDARD

TYPE : KCS077VG2EA-G43

KYOCERA CORPORATION
 KAGOSHIMA HAYATO PLANT
 LCD DIVISION

Original	Designed by :Engineering Dept.			Confirmed by :QA Dept.	
Issue Data	Prepared	Checked	Approved	Checked	Approved
August 2.2002	<i>K. Nishikawa</i>	<i>M. Matsumoto</i>	<i>H. OHNO</i>	<i>S. Hayashi</i>	<i>J. Yoshida</i>

Revision Record

Date	Designed by: Engineering Dept.			Confirmed by: QA Dept.	
	Prepared	Checked	Approved	Checked	Approved
Rev. No.	Date	Page	Descriptions		

Visuals specification

1)Note

Item	Note
General	<p>1. When defects specified in this Inspection Standards are inspected, operating voltage(Vop) shall be set at the level where optimized contrast is available. Display quality is applied up to effective viewing area. (Bi-Level INSPECTION)</p> <p>2. This inspection standard about the image quality shall be applied to any defect within the effective viewing area and shall not be applicable to outside of the area.</p> <p>3. Should any defects which are not specified in this standard happen, additional standard shall be determined by mutual agreement between customer and Kyocera.</p> <p>4. Inspection conditions</p> <p>Luminance : 500 Lux minimum . Inspection distance : 300 mm (from the sample) Temperature : 25 ± 5 °C Direction : right above</p>
Definition of Inspection item	<p>Pinhole, Bright spot Black spot, Scratch Foreign particle</p> <p>The color of a small area is different from the remainder. The phenomenon does not change with voltage.</p>
	<p>Contrast variation</p> <p>The color of a small area is different from the remainder. The phenomenon changes with voltage.</p>
	<p>Polarizer (Scratch, Bubble, Dent)</p> <p>Scratch, Bubble and Dent in the polarizer which can be observed in on / off state.</p>

2) Standard

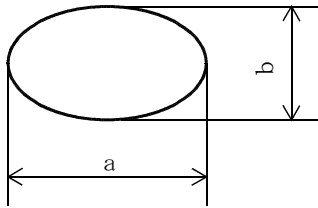
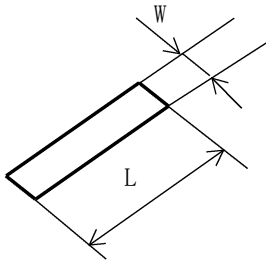
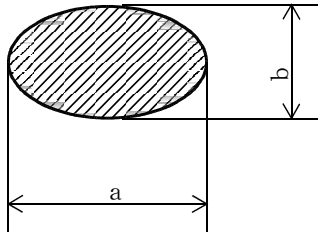
Inspection item	Judgement standard																						
Pinhole, Bright spot Black spot, Foreign particle	<div style="text-align: center;">  $d = (a + b) / 2$ <table border="1" data-bbox="587 566 1393 801"> <thead> <tr> <th>Category</th> <th>Size (mm)</th> <th>Acceptable number</th> </tr> </thead> <tbody> <tr> <td>A</td> <td>$d \leq 0.2$</td> <td>neglected</td> </tr> <tr> <td>B</td> <td>$0.2 < d \leq 0.3$</td> <td>5</td> </tr> <tr> <td>C</td> <td>$0.3 < d \leq 0.5$</td> <td>3</td> </tr> <tr> <td>D</td> <td>$0.5 < d$</td> <td>0</td> </tr> </tbody> </table> </div>	Category	Size (mm)	Acceptable number	A	$d \leq 0.2$	neglected	B	$0.2 < d \leq 0.3$	5	C	$0.3 < d \leq 0.5$	3	D	$0.5 < d$	0							
Category	Size (mm)	Acceptable number																					
A	$d \leq 0.2$	neglected																					
B	$0.2 < d \leq 0.3$	5																					
C	$0.3 < d \leq 0.5$	3																					
D	$0.5 < d$	0																					
Scratch, Foreign particle	<div style="text-align: center;">  <table border="1" data-bbox="557 1169 1422 1473"> <thead> <tr> <th></th> <th>Width (mm)</th> <th>Length (mm)</th> <th>Acceptable No.</th> </tr> </thead> <tbody> <tr> <td>A</td> <td>$W \leq 0.03$</td> <td>—</td> <td>neglected</td> </tr> <tr> <td>B</td> <td rowspan="3">$0.03 < W \leq 0.1$</td> <td>$L \leq 2.0$</td> <td>neglected</td> </tr> <tr> <td>C</td> <td>$2.0 < L \leq 4.0$</td> <td>3</td> </tr> <tr> <td>D</td> <td>$4.0 < L$</td> <td>0</td> </tr> <tr> <td>E</td> <td>$0.1 < W$</td> <td>—</td> <td>According to Circular</td> </tr> </tbody> </table> </div>		Width (mm)	Length (mm)	Acceptable No.	A	$W \leq 0.03$	—	neglected	B	$0.03 < W \leq 0.1$	$L \leq 2.0$	neglected	C	$2.0 < L \leq 4.0$	3	D	$4.0 < L$	0	E	$0.1 < W$	—	According to Circular
	Width (mm)	Length (mm)	Acceptable No.																				
A	$W \leq 0.03$	—	neglected																				
B	$0.03 < W \leq 0.1$	$L \leq 2.0$	neglected																				
C		$2.0 < L \leq 4.0$	3																				
D		$4.0 < L$	0																				
E	$0.1 < W$	—	According to Circular																				
Contrast variation	<div style="text-align: center;">  $d = (a + b) / 2$ <table border="1" data-bbox="587 1818 1393 2007"> <thead> <tr> <th>Category</th> <th>Size (mm)</th> <th>Acceptable number</th> </tr> </thead> <tbody> <tr> <td>A</td> <td>$d \leq 0.5$</td> <td>neglected</td> </tr> <tr> <td>B</td> <td>$0.5 < d \leq 0.7$</td> <td>3</td> </tr> <tr> <td>C</td> <td>$0.7 < d$</td> <td>0</td> </tr> </tbody> </table> </div>	Category	Size (mm)	Acceptable number	A	$d \leq 0.5$	neglected	B	$0.5 < d \leq 0.7$	3	C	$0.7 < d$	0										
Category	Size (mm)	Acceptable number																					
A	$d \leq 0.5$	neglected																					
B	$0.5 < d \leq 0.7$	3																					
C	$0.7 < d$	0																					

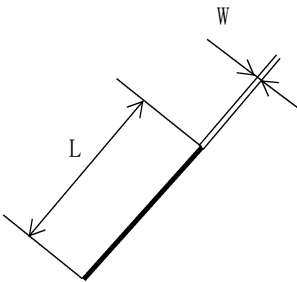
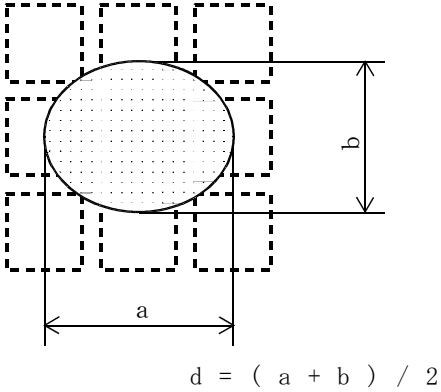
Inspection item	Judgement standard																			
Polarizer (Scratch, Bubble, Dent)	<p data-bbox="544 248 708 277">(1) Scratch</p>  <table border="1" data-bbox="560 689 1422 1021"> <thead> <tr> <th></th> <th>Width (mm)</th> <th>Length (mm)</th> <th>Acceptable No.</th> </tr> </thead> <tbody> <tr> <td>A</td> <td>$W \leq 0.1$</td> <td>—</td> <td>neglected</td> </tr> <tr> <td>B</td> <td rowspan="2">$0.1 < W \leq 0.3$</td> <td>$L \leq 5.0$</td> <td>neglected</td> </tr> <tr> <td>C</td> <td>$5.0 < L$</td> <td>0</td> </tr> <tr> <td>D</td> <td>$0.3 < W$</td> <td>—</td> <td>0</td> </tr> </tbody> </table>		Width (mm)	Length (mm)	Acceptable No.	A	$W \leq 0.1$	—	neglected	B	$0.1 < W \leq 0.3$	$L \leq 5.0$	neglected	C	$5.0 < L$	0	D	$0.3 < W$	—	0
	Width (mm)	Length (mm)	Acceptable No.																	
A	$W \leq 0.1$	—	neglected																	
B	$0.1 < W \leq 0.3$	$L \leq 5.0$	neglected																	
C		$5.0 < L$	0																	
D	$0.3 < W$	—	0																	
	<p data-bbox="544 1070 807 1099">(2)Bubble (dent)</p>  <table border="1" data-bbox="587 1675 1393 2007"> <thead> <tr> <th>Category</th> <th>Size (mm)</th> <th>Acceptable number</th> </tr> </thead> <tbody> <tr> <td>A</td> <td>$d \leq 0.2$</td> <td>neglected</td> </tr> <tr> <td>B</td> <td>$0.2 < d \leq 0.3$</td> <td>5</td> </tr> <tr> <td>C</td> <td>$0.3 < d \leq 0.5$</td> <td>3</td> </tr> <tr> <td>D</td> <td>$0.5 < d$</td> <td>0</td> </tr> </tbody> </table>	Category	Size (mm)	Acceptable number	A	$d \leq 0.2$	neglected	B	$0.2 < d \leq 0.3$	5	C	$0.3 < d \leq 0.5$	3	D	$0.5 < d$	0				
Category	Size (mm)	Acceptable number																		
A	$d \leq 0.2$	neglected																		
B	$0.2 < d \leq 0.3$	5																		
C	$0.3 < d \leq 0.5$	3																		
D	$0.5 < d$	0																		