

5GHz WLAN 802.11ax Front-End Module

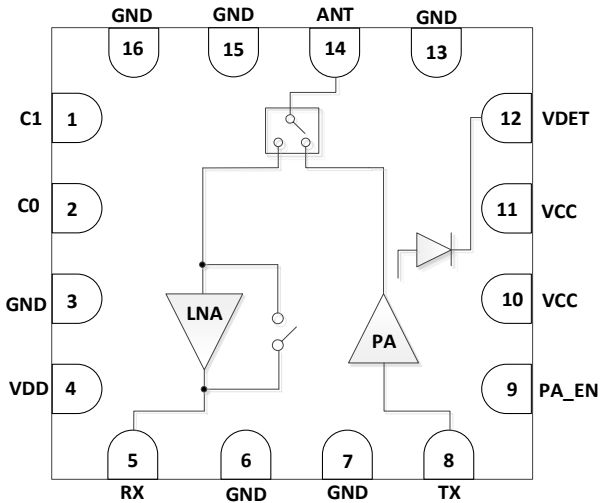

Description

KCT8539HE is a highly integrated RF Front-End Integrated Circuit incorporates key RF functionality needed for IEEE 802.11a/n/ac/ax WLAN systems operating in the 5.15-5.85GHz range. KCT8539HE integrates a high-efficiency high-linearity power amplifier (PA), a low noise amplifier (LNA) with bypass, the associated matching network, and harmonic filters all in one device.

KCT8539HE has simple and low-voltage control logic, and requires minimal external components. A power detector is also integrated to accurately monitor the output power of the PA.

KCT8539HE is assembled in a compact, low-profile 3x3x0.75mm 16-lead QFN package. KCT8539HE is the ideal RF front-end solution for implementing 5GHz high-power WLAN systems supporting multiple standards including 802.11a/n/ac/ax.

Applications

- ▶ 802.11ax Wi-Fi Devices
- ▶ Tablets / MIDs
- ▶ Wi-Fi Media Gateways
- ▶ Consumer Electronics
- ▶ Notebook / Netbook / Ultrabook
- ▶ Access Points / Routers
- ▶ Set Top Boxes / Wireless IPTVs
- ▶ Other 5GHz ISM Platforms

FEATURES

- ▶ Integrated 802.11ax 5GHz PA, LNA with bypass and T/R switch
- ▶ Fully-matched input and output
- ▶ Integrated power detector
- ▶ Transmit gain: 31.0dB at 5V
- ▶ Receive gain: 16.5dB at 5V
- ▶ Noise Figure: 1.7dB at 5V
- ▶ Output power: +20.5dBm @ -43dB DEVM, HE160/MCS11,5V
- ▶ +21.5dBm @ -40dB DEVM, HE160/MCS11,5V
- ▶ +23.0dBm @ -35dB DEVM, VHT80/MCS9,5V
- ▶ +24.0dBm @ -30dB DEVM, HT20/MCS7,5V
- ▶ ESD protection circuitry on all PINs
- ▶ Minimal external components required
- ▶ Small package: QFN-16L, 3mm x 3mm x 0.75mm (MSL3, 260 °C per JEDEC J-STD-020)
- ▶ RoHS and REACH Compliant

PIN ASSIGNMENTS

Pin Number	Pin Name	Description
1	C1	Control Pin 1
2	C0	Control Pin 0
3,6,7,13,15,16,17	GND	Ground – must be connected to ground in the application circuit
4	VDD	LNA Supply Voltage
5	RX	RF output port from LNA or Bypass – DC shorted to ground
8	TX	RF input port from the Transceiver – DC shorted to ground
9	PA_EN	PA Enable
10,11	VCC	PA Supply Voltage
12	VDET	DC power detector
14	ANT	Antenna port – RF signal from the PA or RF signal applied to the LNA – DC shorted to ground

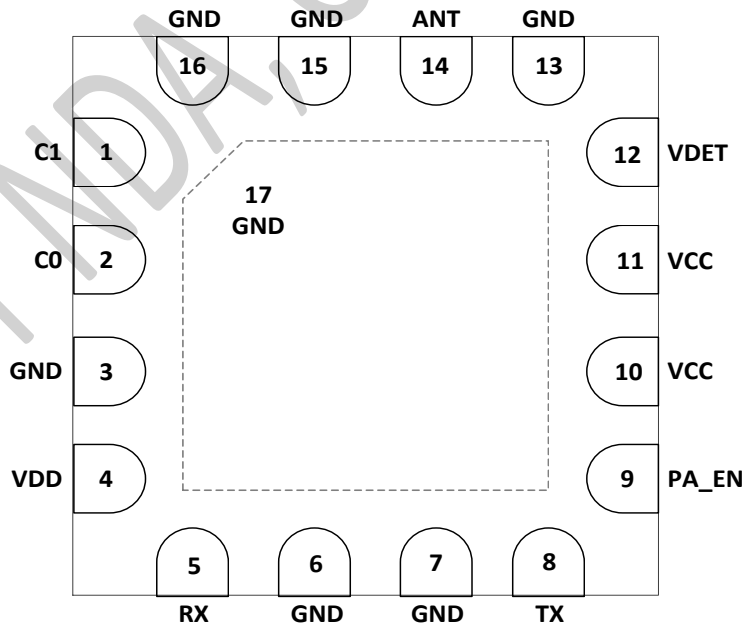
PIN-OUT DIAGRAM (Top View)

ABSOLUTE MAXIMUM RATINGS

Parameters	Units	Min	Max	Conditions
DC Supply Voltage	V	-0.5	+6.0	VDD and VCC Pins
Control Voltage	V	-0.5	+3.6	All Control Pins
TX Mode Maximum Input Power (50ohm load, No Damage)	dBm		+18	
Receive Mode Maximum Input Power (No Damage)	dBm		+18	
Receive Bypass Mode Maximum Input Power (No Damage)	dBm		+21	
Storage Temperature	°C	-40	+150	
Junction Temperature	°C		+175	
Thermal Resistance(θ_{JC})	°C/W		+35	
Ruggedness (Pin =10dBm, No Permanent Damage)	VSWR		10:1	

NOTE: Sustained operation at or above the Absolute Maximum Ratings for any one or combinations of the above parameters may result in permanent damage to the device and is not recommended.

All Maximum RF Input Power Ratings assume 50-ohm terminal impedance.

NOMINAL OPERATING CONDITIONS

Parameters	Units	Min	Typical	Max	Conditions
DC Supply Voltage	V	4.75	5.00	5.25	VDD and VCC Pins
Control Pin Voltage- Logic High	V	1.6		3.6	
Control Pin Voltage- Logic Low	V	0		0.4	
Control Pin DC Current PA_EN C0 C1	μ A		190 150 140		@1.6V
Operating Temperature	°C	-40	+25	+85	

KCT8539HE ELECTRICAL SPECIFICATIONS

(VDD=VCC =5V, T = 25 °C, All Unused Ports Terminated with 50 Ω , Unless Otherwise Noted)

Parameters	Units	Min	Typ	Max	Conditions
Frequency Range	GHz	5.15		5.85	
Transmit Mode					
Gain	dB	29.0	31.0	33.5	CW Signal; Input Power=-25dBm
Gain Flatness	dB		\pm 0.5		Across any 160MHz bandwidth
Output Power	dBm	+18.5 +22.0 +23.0 +25.5	+20.5 +21.5 +23.0 +24.0 +27.0		With -50dB EVM source, AT off: DEVM=-43dB, HE160/MCS11/200 μ s, Preamble only DEVM=-40dB, HE160/MCS11/200 μ s, Preamble only DEVM=-35dB, VHT80/MCS9/200 μ s, Preamble only DEVM=-30dB, HT20/MCS7/200 μ s, Preamble only HT20/MCS0, Mask Compliance

Parameters	Units	Min	Typ	Max	Conditions
Output Power of P1dB	dBm	28.0	29.5		
Current	mA	200 265 300 310 420	230 310 350 370 480	260 355 400 430 550	100% duty modulated signal @ No RF @+21.5dBm @+23.0dBm @+24.0dBm @+27.0dBm
Harmonics 2 nd Harmonics 3 rd Harmonics	dBm/MHz		-30 -40	-25 -35	Pout=+27.0dBm, HT20/MCS0
Input Return Loss	dB		9		
Output Return Loss	dB		12		
Power Detector Output	V	0.02 0.24 0.69 0.77 0.90	0.09 0.32 0.77 0.86 1.00	0.16 0.40 0.85 0.95 1.10	100% duty modulated signal @ No RF @+10.0dBm @+21.5dBm @+24.0dBm @+27.0dBm
Detector Slope	mV/dB		40		From 10dBm to 27dBm
Isolation	dB	38 10	42 15		From ANT to RX Pin From TX to RX Pin
PA Switching Time	ns		350	450	From 50% logic level change to 90%/10% power level TX <-> SD
Receive Mode – LNA On					
Gain	dB	15.0	16.5	19.0	
Noise Figure	dB		1.7	2.2	
2.4G Rejection	dB		22		
Input Power of P1dB	dBm	-4	-2		
Input Return Loss	dB		7		
Output Return Loss	dB		8		
Isolation	dB	13 28	17 32		From ANT to TX Pin From RX to TX Pin
Switching Time	ns		200 350	300 450	From 50% logic level change to 90%/10% power level LNA <-> Bypass LNA <-> TX
LNA current	mA		29		
Receive Bypass Mode					
Insertion Loss	dB	2.5	4.5	6.5	
Input Power of P1dB	dBm	18	20		
Input Return Loss	dB		7		
Output Return Loss	dB		10		
Isolation	dB	33 30	38 35		From ANT to TX Pin From RX to TX Pin

Parameters	Units	Min	Typ	Max	Conditions
Bypass Current	mA	0.5	1.0	2.0	

CONTROL LOGIC TABLE

PA_EN	C0	C1	Mode of Operation
1	0	1	Transmit Mode
0	1	0	Receive LNA Mode
0	1	1	Receive Bypass Mode
0	0	0	Shutdown Mode

Note: "1" denotes high voltage state at Control Pins
 "0" denotes low voltage state at Control Pins

PRODUCT QUALIFICATION

Parameters	Units	Min	Max	Conditions
ESD – Human Body Mode	V		1000	HBM
ESD – Charge Device Mode	V		2000	CDM
HTOL	/	1000 hours pass		Refer to JESD22-A108, JESD85

ESD HANDLING: Although this device is designed to be as robust as possible, electrostatic discharge (ESD) can damage this device. This device must be protected at all times from ESD when handling or transporting. Static charges may easily produce potentials of several kilovolts on the human body or equipment, which can discharge without detection.

Industry-standard ESD handling precautions should be used at all times.

ORDERING INFORMATION

Product Description	Product Part Number	Package Type	Package Quantity
KCT8539HE:5GHz WLAN Front-End Module	KCT8539HE	13" tape and reel	5000pcs / reel

APPLICATION SCHEMATIC

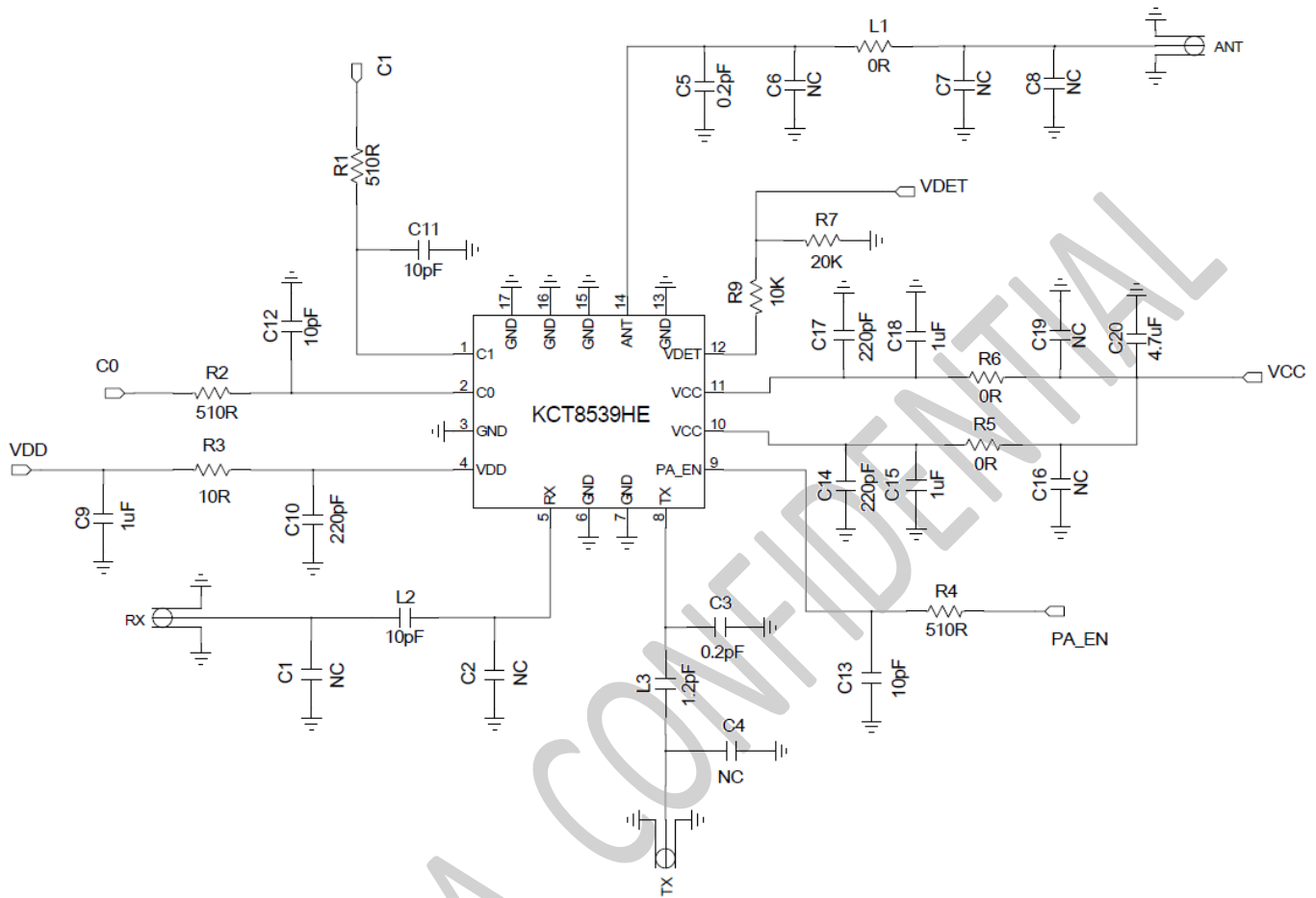

EVB PICTURE and EVB BOM

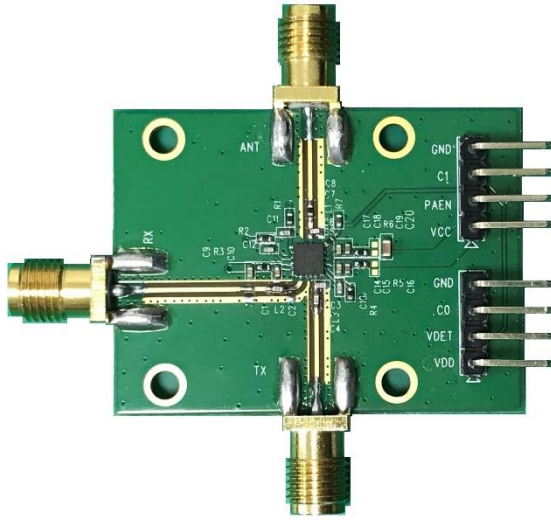

[EVB Assembly]

Designator	Value	Footprint	Notes
C3,C5	0.2PF	0402	Murata C0G series
L3	1.2PF	0402	Murata C0G series
L2,C11,C12,C13	10PF	0402	Murata C0G series
C10,C14,C17	220PF	0402	Murata X5R/X7R series
C9,C15,C18	1 μ F	0402	Murata X5R/X7R series
C20	4.7 μ F	0603	Murata X5R/X7R series
L1,R5,R6	0 ohm	0402	Yageo RC0402 series
R3	10 ohm	0402	Yageo RC0402 series
R9	10K ohm	0402	Yageo RC0402 series
R7	20K ohm	0402	Yageo RC0402 series
R1,R2,R4	510 ohm	0402	Yageo RC0402 series Control pin protect resistor

PCB LAYOUT FOOTPRINT (All dimensions are in millimeters)

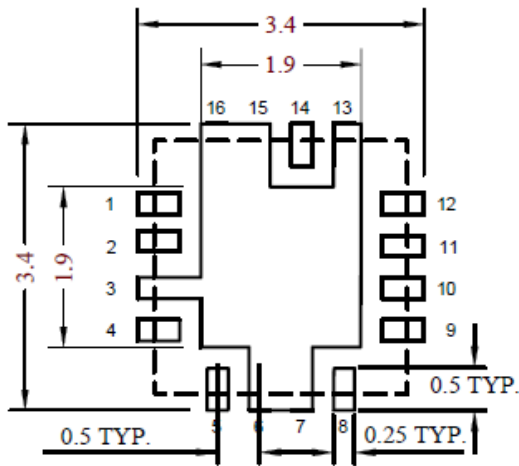

Board Metal

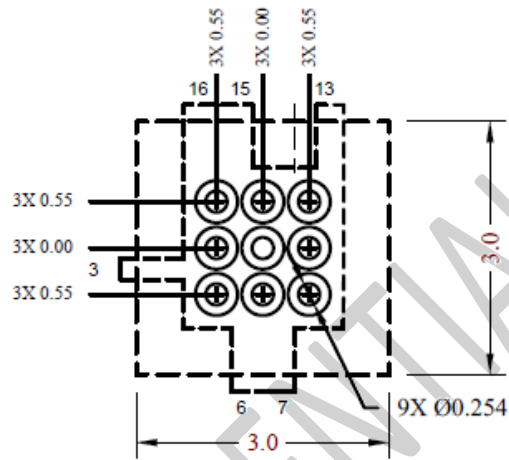

Via Pattern

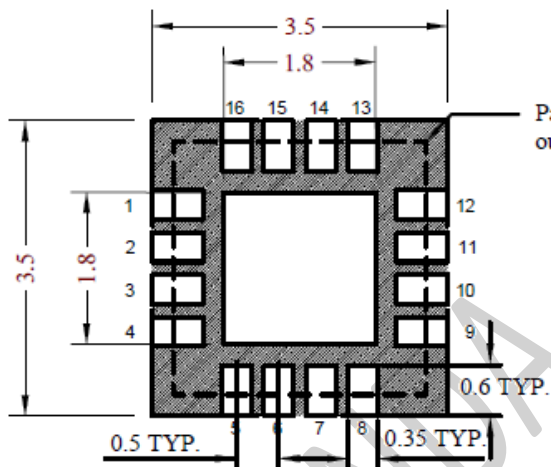

Solder Mask Pattern

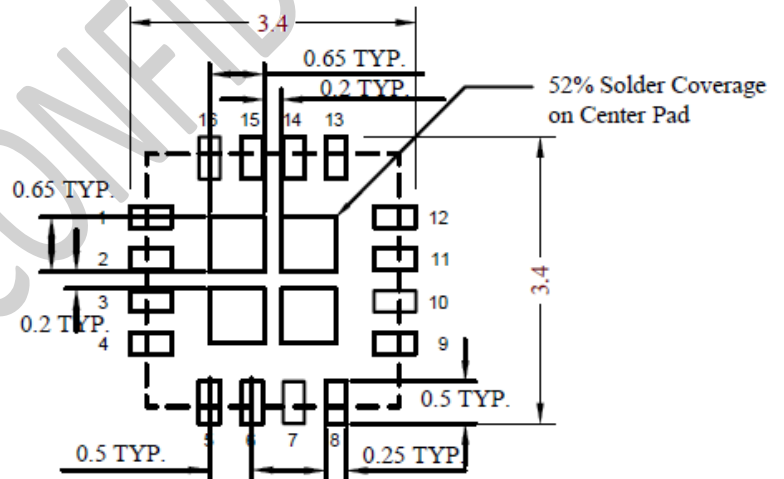

Stencil Pattern

Package Dimensions (All dimensions are in millimeters)

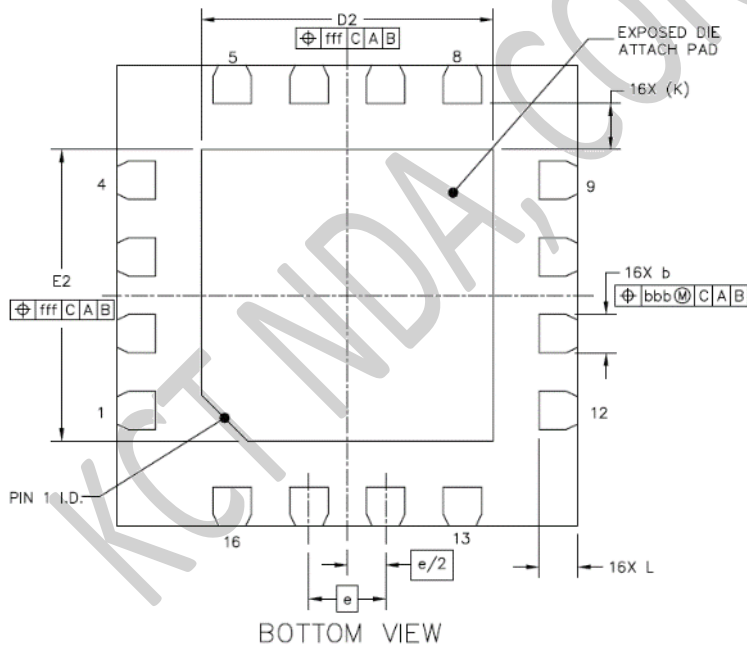
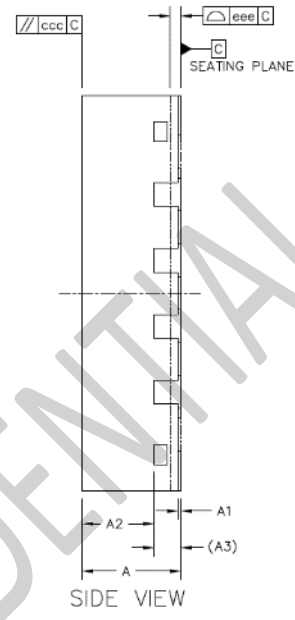
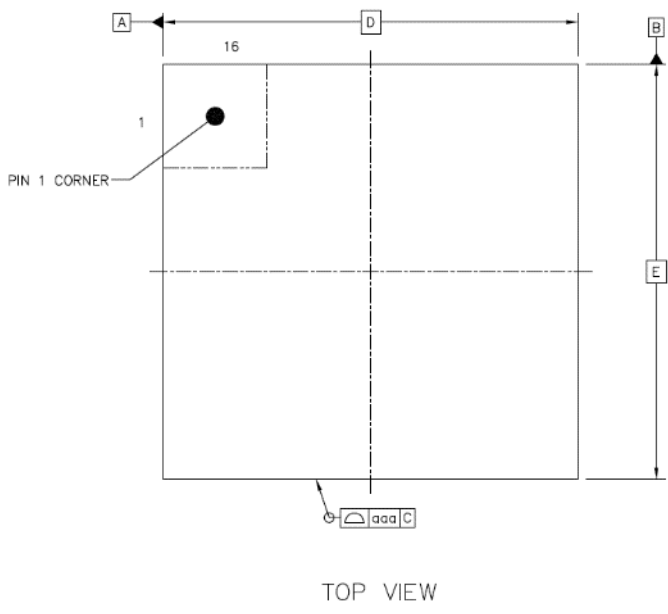

	SYMBOL	MIN	NOM	MAX	
TOTAL THICKNESS	A	0.7	0.75	0.8	
STAND OFF	A1	0	0.02	0.05	
MOLD THICKNESS	A2	---	0.55	---	
L/F THICKNESS	A3	0.203 REF			
LEAD WIDTH	b	0.2	0.25	0.3	
BODY SIZE	X	3 BSC			
	Y	3 BSC			
LEAD PITCH	e	0.5 BSC			
EP SIZE	X	D2	1.8	1.9	2
	Y	E2	1.8	1.9	2
LEAD LENGTH	L	0.15	0.25	0.35	
LEAD TIP TO EXPOSED PAD EDGE	K	0.3 REF			
PACKAGE EDGE TOLERANCE	aaa	0.1			
MOLD FLATNESS	ccc	0.1			
COPLANARITY	eee	0.08			
LEAD OFFSET	bbb	0.1			
EXPOSED PAD OFFSET	fff	0.1			

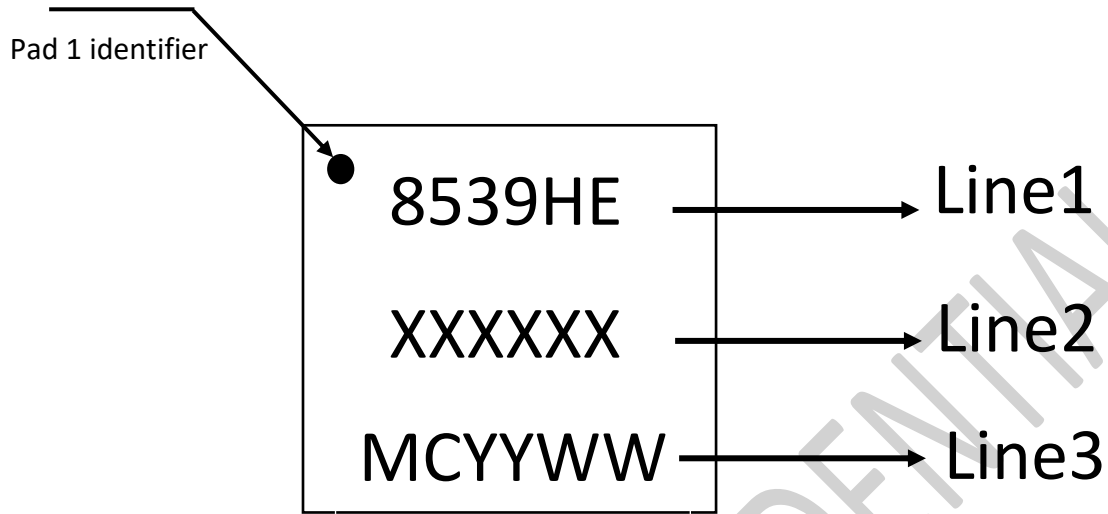
PART MARKING

Line	Marking	Description
1	8539HE	Product name
2	XXXXXX	Lot information
3	MCYYWW	MC: Manufacturer Code YYWW: YY year WW week

PIN 1 DIRECTION IN CARRIER TAPE

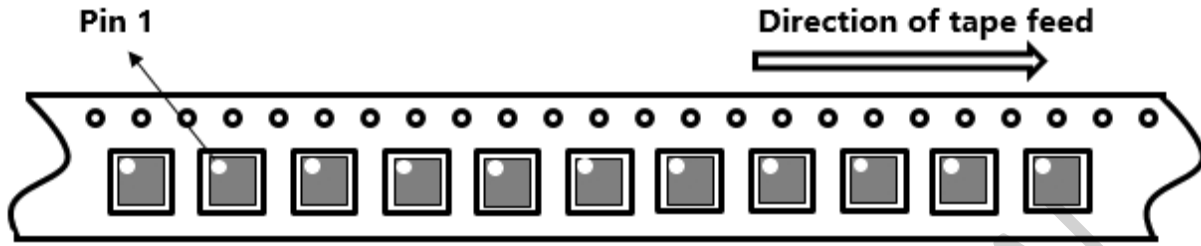

KCT NDA, CONFIDENTIAL