



**SPECIFICATION  
FOR  
LCM Module  
KD070WVFLA011**

MODULE:	KD070WVFLA011
CUSTOMER:	

REV	DESCRIPTION	DATE
1.0	FIRST ISSUE	2017.10.31

STARTEK	INITIAL	DATE
PREPARED BY		
CHECKED BY		
APPROVED BY		

CUSTOMER	INITIAL	DATE
APPROVED BY		

Part. No	KD070WVFLA011	REV	V1.0	Page 1 of 26
----------	---------------	-----	------	--------------

常备库存  
Stock For Sale

长期供货  
Long Time supply

支持小量  
NO MOQ

品种齐全  
In Full Range



### Revision History

Date	Rev. No.	Page	Summary
2017.10.31	V1.0	ALL	FIRST ISSUE

ISO 9001:2008  
ISO/TS16949:2009



## Contents

1. Block Diagram .....	5
2. Outline dimension .....	6
3. Input terminal Pin Assignment .....	7
4. LCD Optical Characteristics .....	9
4.1 Optical specification .....	9
5. Electrical Characteristics .....	11
5.1 Absolute Maximum Rating (Ta=25 VSS=0V) .....	11
5.2 DC Electrical Characteristics .....	11
5.3 LED Backlight Characteristics .....	12
6. AC Characteristic .....	14
6.1 LVDS receiver characteristic .....	14
6.2 Power on/off Sequence .....	16
7. LCD Module Out-Going Quality Level .....	17
7.1 VISUAL & FUNCTION INSPECTION STANDARD .....	17
7.1.1 Inspection conditions .....	17
7.1.3 Sampling Plan .....	18
7.1.4 Criteria (Visual) .....	19
8. Reliability Test Result .....	24
9. Cautions and Handling Precautions .....	25
9.1 Handling and Operating the Module .....	25
9.2 Storage and Transportation .....	25
10. Packing .....	26

Part. No	KD070WVFLA011	REV	V1.0	Page 3 of 26
----------	---------------	-----	------	--------------

常备库存  
Stock For Sale

长期供货  
Long Time supply

支持小量  
NO MOQ

品种齐全  
In Full Range



**\* Description**

This is a color active matrix TFT (Thin Film Transistor) LCD (liquid crystal display) that uses amorphous silicon TFT as a switching device. This model is composed of a Transmissive type TFT-LCD Panel, driver circuit, back-light unit. The resolution of a 7.0'TFT-LCD contains 800X480 pixels, and can display up to 65K/262K/16.7M colors.

**\* Features**

-Low Input Voltage: 3.3V(TYP)

-Display Colors of TFT LCD: 65K/262K/16.7M colors

Interface: 6/8BIT LVDS

General Information Items	Specification	Unit	Note
	Main Panel		
Display area(AA)	152.40(H) *91.44(V) (7.0inch )	mm	-
Driver element	TFT active matrix	-	-
Display colors	65K/262K/16.7M	colors	-
Number of pixels	800(RGB)*480	dots	-
TFT Pixel arrangement	RGB vertical stripe	-	-
Pixel pitch	0.1905(H) x 0.1905 (V)	mm	-
Viewing angle	ALL	o'clock	-
TFT Controller IC	SC5004/SC5005	-	-
Display mode	Transmissive/Normally Black	-	-
Operating temperature	-30~+85	°C	-
Storage temperature	-40~+90	°C	-

**\* Mechanical Information**

Item		Min.	Typ.	Max.	Unit	Note
Module size	Horizontal(H)		165.40		mm	-
	Vertical(V)		104.59		mm	-
	Depth(D)		5.8		mm	-
Weight			TBD		g	-



### 1. Block Diagram

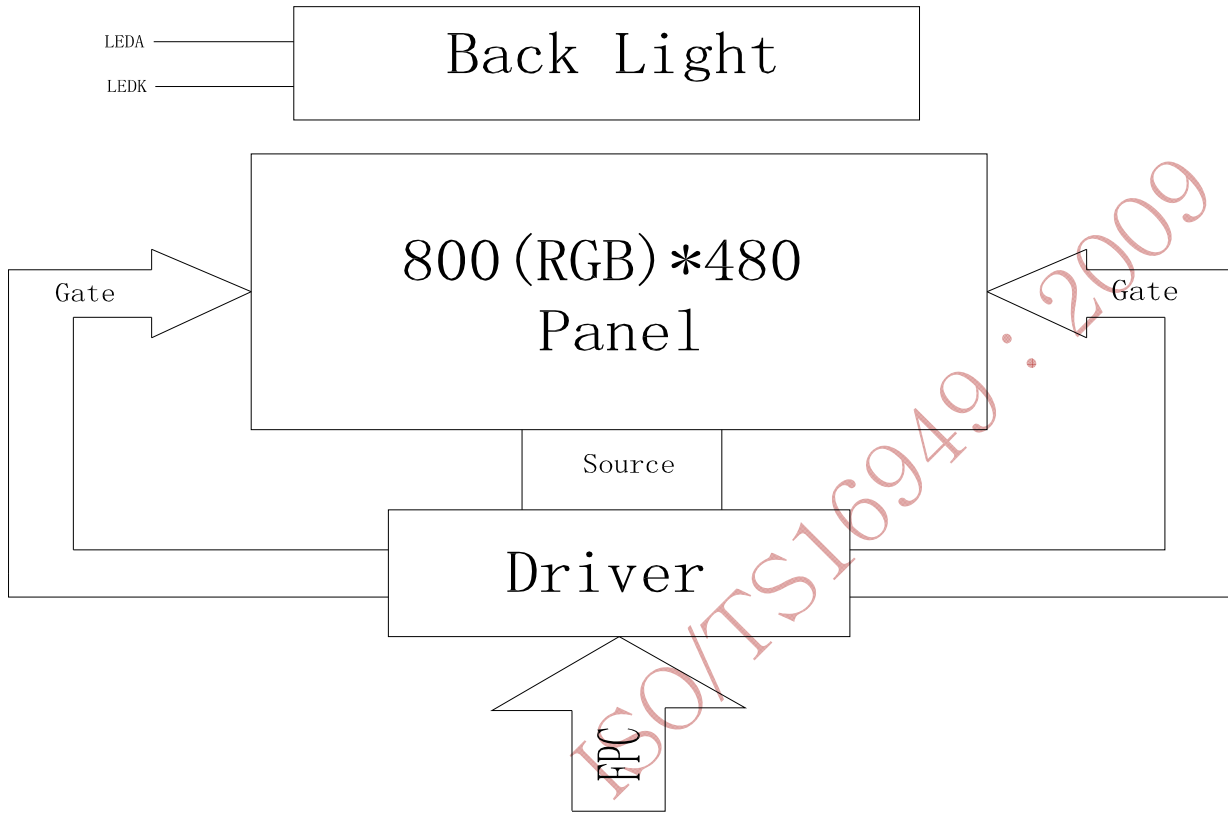

Part. No	KD070WVFLA011	REV	V1.0	Page 5 of 26
	常备库存 Stock For Sale	长期供货 Long Time supply	支持少量 NO MOQ	品种齐全 In Full Range



2. Outline dimension

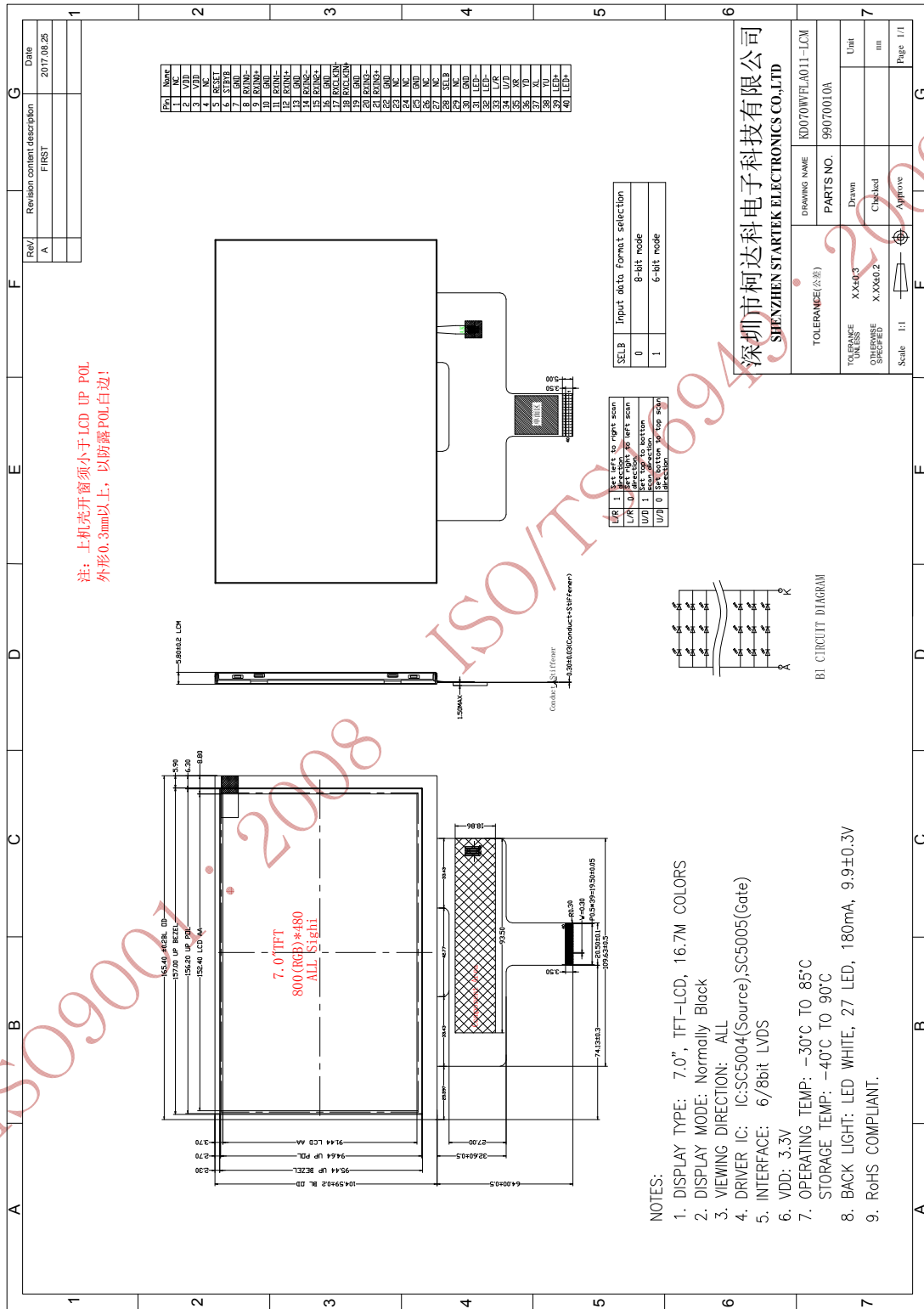

Part. No	KD070WVFLA011	REV	V1.0	Page 6 of 26
----------	---------------	-----	------	--------------

常备库存  
Stock For Sale

长期供货  
Long Time supply

支持小量  
NO MOQ

品种齐全  
In Full Range



### 3. Input terminal Pin Assignment

NO.	SYMBOL	DISCRIPTION	I/O
1	NC		
2	VDD	Supply voltage(3.3V).	P
3	VDD	Supply voltage(3.3V).	P
4	NC		
5	RESET	Reset pin. The chip is in reset state when RESETB=0.	I
6	STBYB	Standby mode setting pin. The chip is in standby mode when S TBYB=0.	I
7	GND	Ground.	P
8	RXIN0-	- LVDS differential data input	I
9	RXIN0+	+ LVDS differential data input	I
10	GND	Ground.	P
11	RXIN1-	- LVDS differential data input	I
12	RXIN1+	+ LVDS differential data input	I
13	GND	Ground.	P
14	RXIN2-	- LVDS differential data input	I
15	RXIN2+	+ LVDS differential data input	I
16	GND	Ground.	P
17	RXCLKIN-	- LVDS differential clock input	I
18	RXCLKIN+	+ LVDS differential clock input	I
19	GND	Ground.	P
20	RXIN3-	- LVDS differential data input	I
21	RXIN3+	+ LVDS differential data input	I
22	GND	Ground.	P
23	NC		
24	NC		
25	GND	Ground.	P

Part. No	KD070WVFLA011	REV	V1.0	Page 7 of 26
----------	---------------	-----	------	--------------

常备库存  
Stock For Sale

长期供货  
Long Time supply

支持少量  
NO MOQ

品种齐全  
In Full Range



26	NC		
27	NC		
28	SLEB	Input data format selection. SLEB=0, 8-BIT SLEB=1, 6-BIT	I
29	NC		
30	GND	Ground.	I
31	LED-	LED Cathode	P
32	LED-	LED Cathode	P
33	L/R	Horizontal shift direction (source output) selection(NOTE1)	I
34	U/D	Vertical shift direction (gate output) selection(NOTE1)	I
35	XR	Touch panel Right Glass Terminal	A/D
36	YD	Touch panel Bottom Film Terminal	A/D
37	XL	Touch panel LIFT Glass Terminal	A/D
38	YU	Touch panel Top Film Terminal	A/D
39	LED+	LED Anode	P
40	LED+	LED Anode	P

**NOTE1**

L/R	1	Set left to right scan direction
L/R	0	Set right to left scan direction.
U/D	1	Set top to bottom scan direction
U/D	0	Set bottom to top scan direction





## 4. LCD Optical Characteristics

### 4.1 Optical specification

Item	Symbol	Condition	Min.	Typ.	Max.	Unit.	Note
Contrast Ratio	CR	$\Theta=0$	--	1000	--		2
Response time	Rising	Normal viewing angle	--	35	40	msec	3
	Falling		--				
Color gamut	S(%)		--	70	--	%	
Color Filter Chromaticity	White	$W_x$	0.287	0.307	0.347		
		$W_y$	0.306	0.346	0.386		
	Red	$R_x$	0.619	0.639	0.659		
		$R_y$	0.318	0.338	0.358		
	Green	$G_x$	0.307	0.327	0.347		
		$G_y$	0.558	0.578	0.598		
	Blue	$B_x$	0.123	0.143	0.163		
		$B_y$	0.047	0.067	0.087		
Viewing angle	Hor.	$\Theta_L$	--	85	--		
		$\Theta_R$	--	85	--		
	Ver.	$\Theta_U$	--	85	--		
		$\Theta_D$	--	85	--		
Option View Direction	Free						

Part. No	KD070WVFLA011	REV	V1.0	Page 9 of 26
----------	---------------	-----	------	--------------

常备库存  
Stock For Sale

长期供货  
Long Time supply

支持小量  
NO MOQ

品种齐全  
In Full Range



Note (2) Definition of Contrast Ratio (CR) :  
measured at the center point of panel

$$CR = \frac{\text{Luminance with all pixels white}}{\text{Luminance with all pixels black}}$$

2009

Note (3) Definition of Response Time : Sum of  $T_R$  and  $T_F$

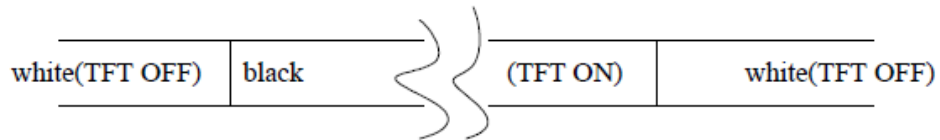

Optical response

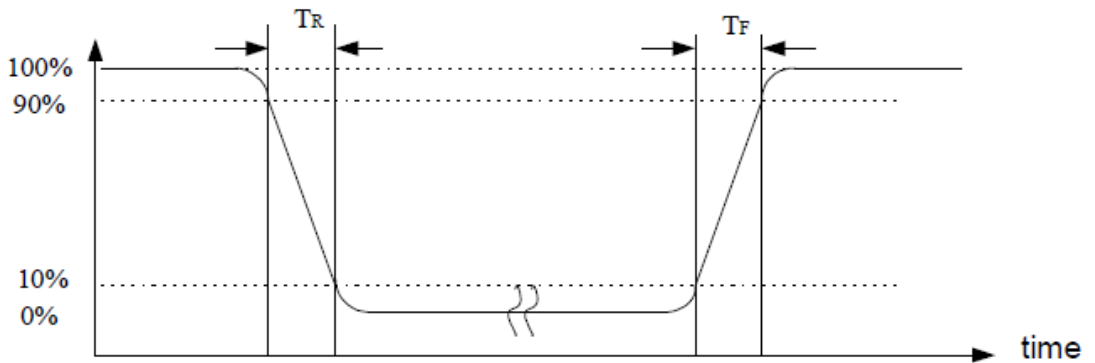

ISO9001

Part. No	KD070WVFLA011	REV	V1.0	Page 10 of 26
----------	---------------	-----	------	---------------

常备库存  
Stock For Sale

长期供货  
Long Time supply

支持小量  
NO MOQ

品种齐全  
In Full Range



## 5. Electrical Characteristics

### 5.1 Absolute Maximum Rating (Ta=25 VSS=0V)

Characteristics	Symbol	Min.	Max.	Unit
Digital Supply Voltage	VDD	-0.3	4.0	V
Operating temperature	T <sub>OP</sub>	-30	+85	°C
Storage temperature	T <sub>ST</sub>	-40	+90	°C

NOTE: If the absolute maximum rating of even is one of the above parameters is exceeded even momentarily, the quality of the product may be degraded. Absolute maximum ratings, therefore, specify the values exceeding which the product may be physically damaged. Be sure to use the product within the range of the absolute maximum ratings.

### 5.2 DC Electrical Characteristics

Characteristics	Symbol	Min.	Typ.	Max.	Unit	Note
Digital Supply Voltage	VDD	3.0	3.3	3.6	V	
Digital Supply current	IDD	--	TBD	--	mA	
Level input voltage	V <sub>IH</sub>	0.7V <sub>DD</sub>		VDD	V	
	V <sub>IL</sub>	GND		0.3V <sub>DD</sub>	V	
Level output voltage	V <sub>OH</sub>	0.8V <sub>DD</sub>		VDD	V	
	V <sub>OL</sub>	GND		0.2V <sub>DD</sub>	V	

Part. No	KD070WVFLA011	REV	V1.0	Page 11 of 26
----------	---------------	-----	------	---------------

常备库存  
Stock For Sale

长期供货  
Long Time supply

支持小量  
NO MOQ

品种齐全  
In Full Range



### 5.3 LED Backlight Characteristics

The back-light system is edge-lighting type with 27 chips White LED

Item	Symbol	Min.	Typ.	Max.	Unit	Note
Forward Current	$I_F$	170	180	--	mA	
Forward Voltage	$V_F$	--	9.9	--	V	
LCM Luminance	$L_v$	350	400	--	cd/m <sup>2</sup>	Note3
LED life time	Hr	50000	--	--	Hour	Note1,2
Uniformity	AVg	80	--	--	%	Note3

Note (1) LED life time (Hr) can be defined as the time in which it continues to operate under the condition:

$T_a=25\pm3\text{ }^\circ\text{C}$ , typical IL value indicated in the above table until the brightness becomes less than 50%.

Note (2) The "LED life time" is defined as the module brightness decrease to 50% original brightness at  $T_a=25\text{ }^\circ\text{C}$  and  $I_L=180\text{mA}$ . The LED lifetime could be decreased if operating  $I_L$  is larger than 180mA. The constant current driving method is suggested.

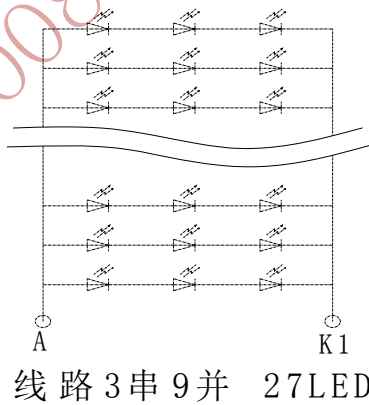

Part. No	KD070WVFLA011	REV	V1.0	Page 12 of 26
----------	---------------	-----	------	---------------

常备库存  
Stock For Sale

长期供货  
Long Time supply

支持小量  
NO MOQ

品种齐全  
In Full Range



NOTE 3: Luminance Uniformity of these 9 points is defined as below:

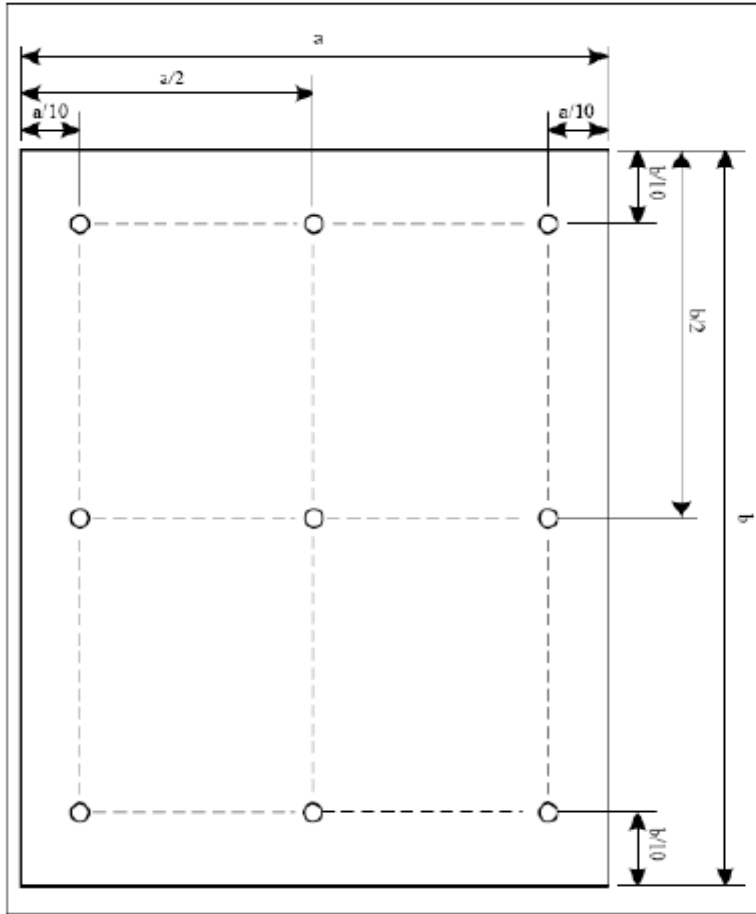

$$\text{Uniformity} = \frac{\text{minimum luminance in 9 points (1-9)}}{\text{maximum luminance in 9 points (1-9)}}$$

$$\text{Luminance} = \frac{\text{Total Luminance of 9 points}}{9}$$

ISO9001

Part. No	KD070WVFLA011	REV	V1.0	Page 13 of 26
----------	---------------	-----	------	---------------

常备库存  
Stock For Sale

长期供货  
Long Time supply

支持小量  
NO MOQ

品种齐全  
In Full Range



## 6. AC Characteristic

### 6.1 LVDS receiver characteristic

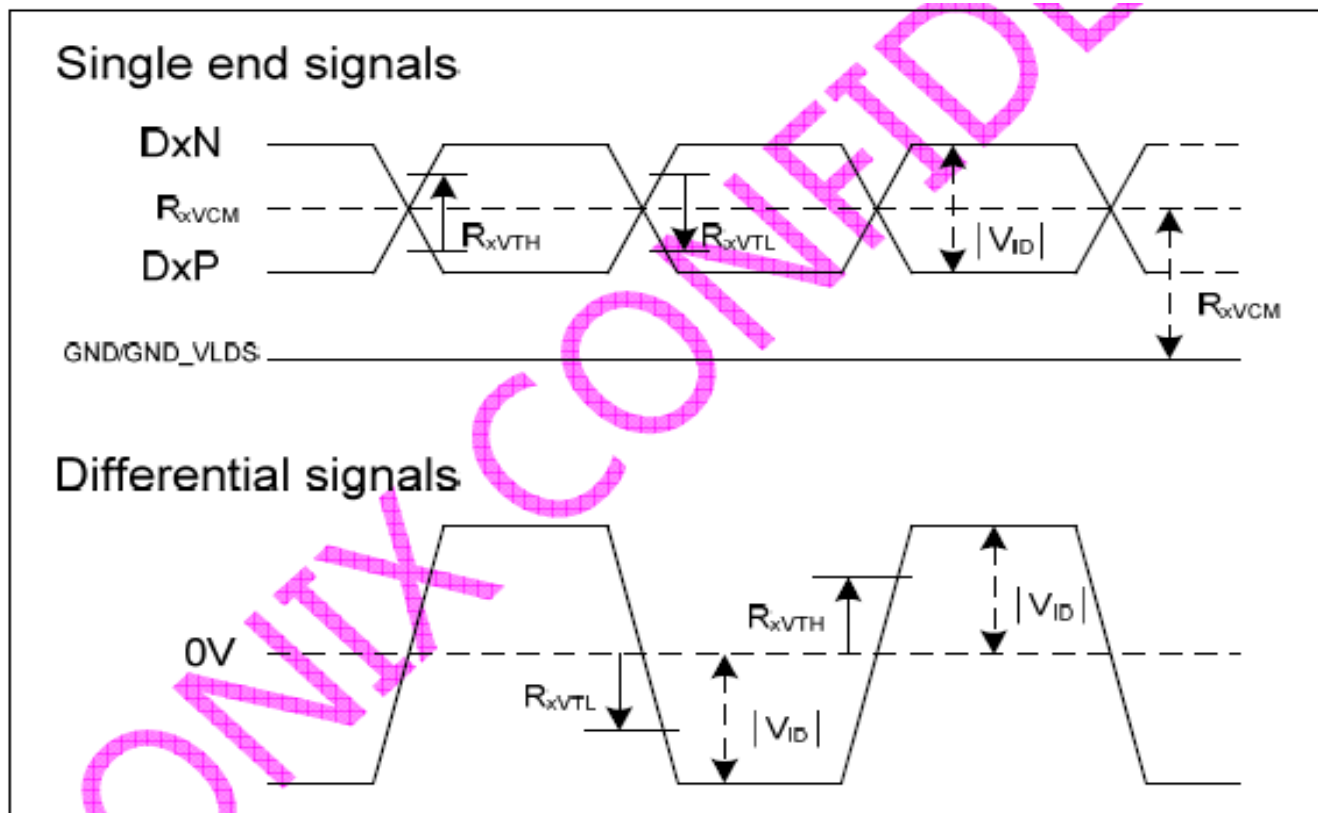

LVDS AC characteristic (VDD=VDD\_LVDS=3.0~3.6V, GND=GND\_LVDS=0V, TA=-20~85°C)

Parameter	Symbol	Min	Typ.	Max.	Unit	Conditions
Clock Frequency	$R_{xFCLK}$	20		80	MHz	
Input data skew margin	$T_{RSKM}$	400			ps	$ V_{ID}  = 400mV, R_{xVCM}=1.2V$ $R_{xFCLK}=80MHz$
Clock high time	$T_{LVCH}$		$4/(7 \times R_{xFCLK})$		ns	
Clock low time	$T_{LVCL}$		$3/(7 \times R_{xFCLK})$		ns	
PLL wake-up time	$T_{enPLL}$			150	us	

Parameter	Symbol	Min	Typ.	Max.	Unit	Conditions
Differential input high threshold voltage	$R_{xVTH}$			0.1	V	$R_{xVCM} = 1.2V$
Differential input low threshold voltage	$R_{xVTL}$	-0.1			V	
Input voltage range (singled-end)	$R_{xVIN}$	0		VDD-1.0	V	
Differential input common mode voltage	$R_{xVCM}$	$ V_{ID} /2$		$2.4 -  V_{ID} /2$	V	
Differential input voltage	$ V_{ID} $	0.2		0.6	V	
Differential input leakage current	$R_{VxIIZ}$	-10		10	uA	
LVDS Digital Operating Current	$I_{VDD\_LVDS}$	-	10	15	mA	$F_{CLK}=65 MHz, V_{DD\_LVDS}=3.3V$ Data pattern=55/H → AA/H (loop)
LVDS Digital Stand-by Current	$I_{STBD\_LVDS}$	-	10	50	uA	RSTB=0 or STBYB=0 All functions are stopped CLKx & D0x connect to GND

Part. No	KD070WVFLA011	REV	V1.0	Page 14 of 26
----------	---------------	-----	------	---------------

常备库存  
Stock For Sale

长期供货  
Long Time supply

支持小量  
NO MOQ

品种齐全  
In Full Range

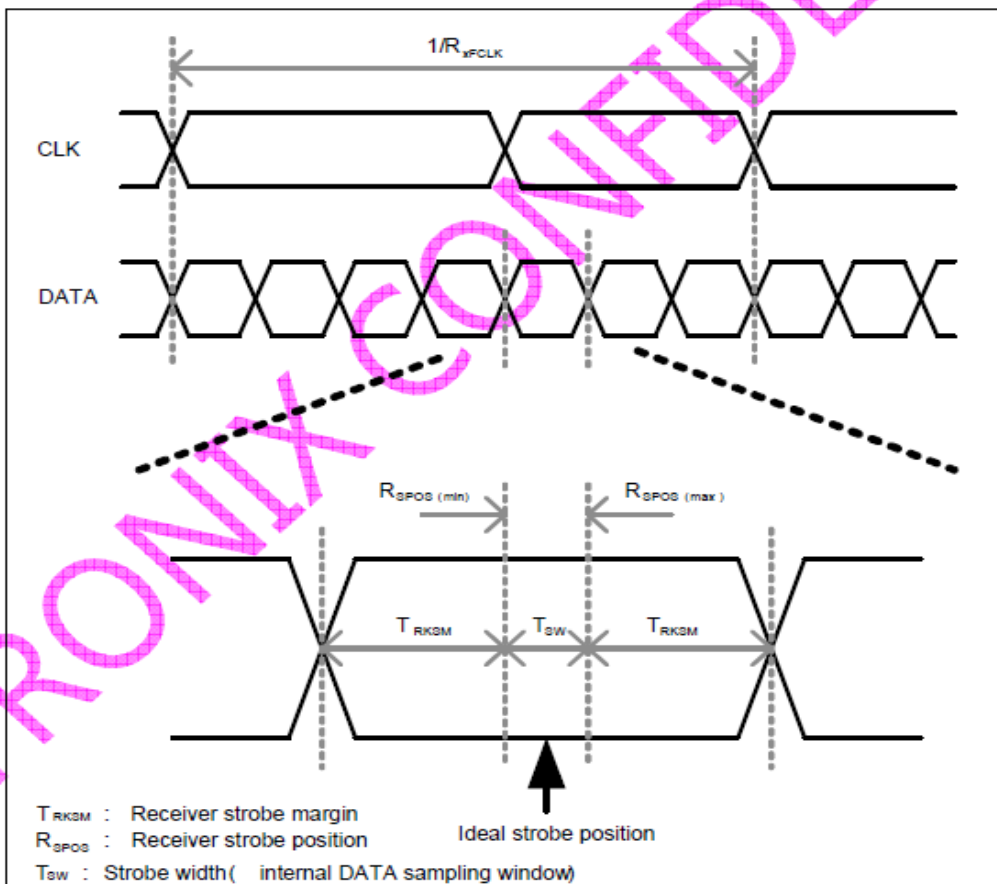
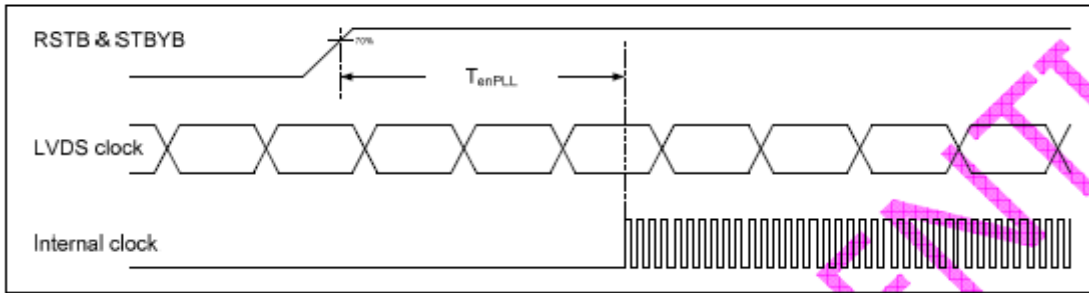
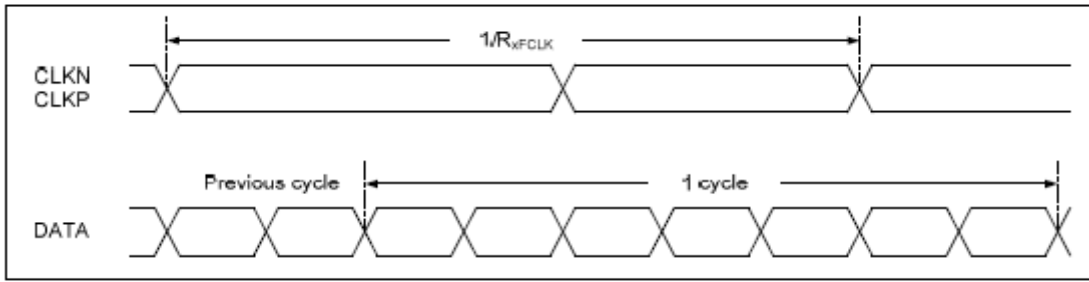

Spread Spectrum Clocking (SSC) tolerance of LVDS receiver

Parameter	Symbol	Min	Typ.	Max.	Unit	Conditions
Modulation frequency	SSCMF			100	kHz	
Modulation rate	SSCMR			+/-3	%	$R_{xFLK}=70MHz$

Part. No	KD070WVFLA011	REV	V1.0	Page 15 of 26
----------	---------------	-----	------	---------------

常备库存  
Stock For Sale

长期供货  
Long Time supply

支持小量  
NO MOQ

品种齐全  
In Full Range



## 6.2 Power on/off Sequence

For TFT-LCD module, please follow below timings to prevent IC damage from abnormal power on or off sequence.

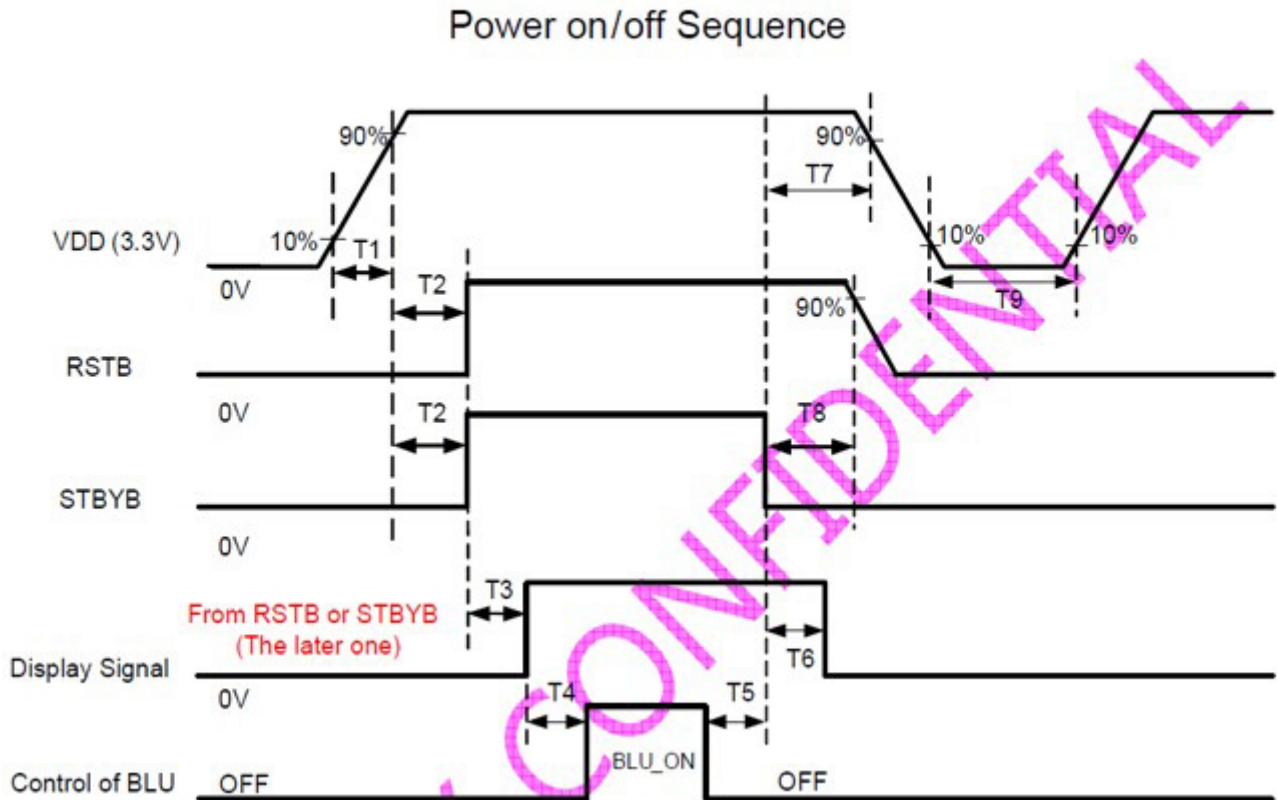

$T1 \leq 3\text{ms}$   
 $1\text{ms} \leq T2$   
 $3.5\text{ms} \leq T3 \leq \text{IBF} - 50\text{ms}$   
 $\text{IBF} + 20\text{ms} \leq T3 + T4$

$0 < T5$   
 $20\text{ms} \leq T6 \leq 50\text{ms}$   
 $120\text{ms} \leq T7$   
 $120\text{ms} \leq T8$   
 $200\text{ms} \leq T9$

For continuously power off and on, please make sure the external VDD, VGH & VGL are discharged completely before you restart it.

Note that IBF is STSC5004's internal timing frames, selected by registers. Please refer to register list for detail.

Part. No	KD070WVFLA011	REV	V1.0	Page 16 of 26
----------	---------------	-----	------	---------------

常备库存  
Stock For Sale

长期供货  
Long Time supply

支持小量  
NO MOQ

品种齐全  
In Full Range





## 7. LCD Module Out-Going Quality Level

### 7.1 VISUAL & FUNCTION INSPECTION STANDARD

#### 7.1.1 Inspection conditions

Inspection performed under the following conditions is recommended.

Temperature : 25±5°C

Humidity : 65%±10%RH

Viewing Angle : Normal viewing Angle.

Illumination: Single fluorescent lamp (300 to 700Lux)

Viewing distance:30-50cm

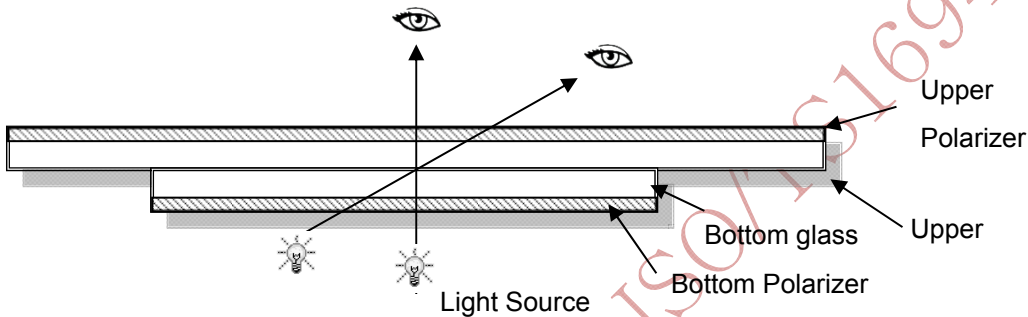

#### 7.1.2 Definition

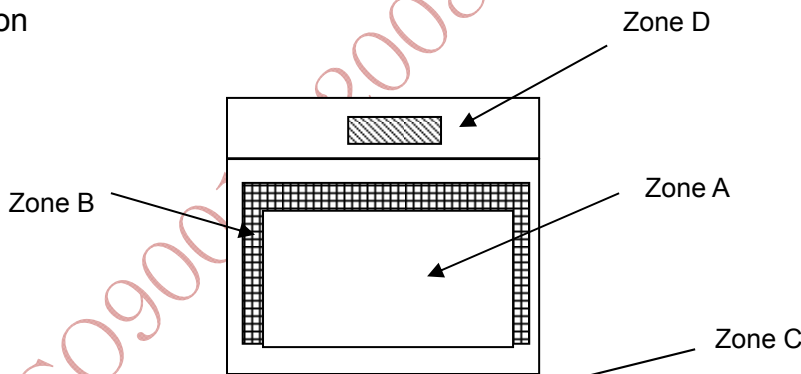

Zone A : Effective Viewing Area(Character or Digit can be seen)

Zone B : Viewing Area except Zone A

Zone C : Outside (Zone A+Zone B) which can not be seen after assembly by customer .)

Zone D : IC Bonding Area

Note:

As a general rule ,visual defects in Zone C can be ignored when it doesn't effect product function or appearance after assembly by customer

Part. No	KD070WVFLA011	REV	V1.0	Page 17 of 26
----------	---------------	-----	------	---------------

常备库存  
Stock For Sale

长期供货  
Long Time supply

支持小量  
NO MOQ

品种齐全  
In Full Range



7.1.3 Sampling Plan

According to GB/T 2828-2003 ; , normal inspection, Class II

AQL:

Major defect	Minor defect
0.65	1.5

LCD: Liquid Crystal Display , TP: Touch Panel , LCM: Liquid Crystal Module

No	Items to be inspected	Criteria	Classification of defects
1	Functional defects	1) No display, Open or miss line 2) Display abnormally, Short 3) Backlight no lighting, abnormal lighting. 4) TP no function	Major
2	Missing	Missing component	
3	Outline dimension	Overall outline dimension beyond the drawing is not allowed	
4	Color tone	Color unevenness, refer to limited sample	Minor
5	Spot Line defect	Light dot, Dim spot, Polarizer Bubble ; Polarizer accidented spot.	
6	Soldering appearance	Good soldering , Peeling off is not allowed.	
7	LCD/Polarizer/TP	Black/White spot/line, scratch, crack, etc.	

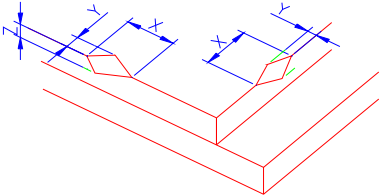
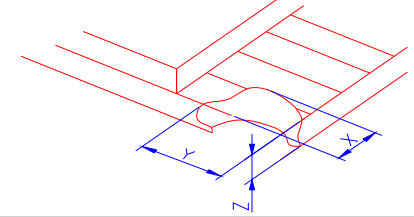
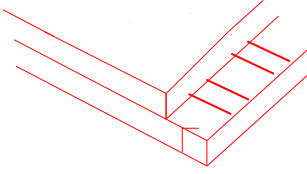

7.1.4 Criteria (Visual)

Number	Items	Criteria(mm)						
1.0 LCD Crack/Broken NOTE: X: Length Y: Width Z: Height L: Length of ITO, T: Height of LCD	(1) The edge of LCD broken	 <table border="1" data-bbox="756 667 1455 815"> <tr> <td>X</td> <td>Y</td> <td>Z</td> </tr> <tr> <td>≤3.0mm</td> <td>&lt;Inner border line of the seal</td> <td>≤T</td> </tr> </table>	X	Y	Z	≤3.0mm	<Inner border line of the seal	≤T
X	Y	Z						
≤3.0mm	<Inner border line of the seal	≤T						
	(2)LCD corner broken	 <table border="1" data-bbox="836 1122 1375 1218"> <tr> <td>X</td> <td>Y</td> <td>Z</td> </tr> <tr> <td>≤3.0mm</td> <td>≤L</td> <td>≤T</td> </tr> </table>	X	Y	Z	≤3.0mm	≤L	≤T
X	Y	Z						
≤3.0mm	≤L	≤T						
	(3) LCD crack	 <p style="text-align: center;">Crack Not allowed</p>						





2.0	<p>Spot defect</p> <p><math>\Phi = (X+Y)/2</math></p>	① light dot (LCD/TP/Polarizer black/white spot , light dot, pinhole, dent, stain)																									
		<table border="1"> <thead> <tr> <th rowspan="2">Zone Size (mm)</th> <th colspan="3">Acceptable Qty</th> </tr> <tr> <th>A</th> <th>B</th> <th>C</th> </tr> </thead> <tbody> <tr> <td><math>\Phi \leq 0.10</math></td> <td colspan="3">Ignore</td> </tr> <tr> <td><math>0.10 &lt; \Phi \leq 0.25</math></td> <td colspan="3">4( distance <math>\geq 10\text{mm}</math>)</td> </tr> <tr> <td><math>0.25 &lt; \Phi \leq 0.35</math></td> <td colspan="3">3</td> </tr> <tr> <td><math>\Phi &gt; 0.4</math></td> <td colspan="3">0</td> </tr> </tbody> </table>			Zone Size (mm)	Acceptable Qty			A	B	C	$\Phi \leq 0.10$	Ignore			$0.10 < \Phi \leq 0.25$	4( distance $\geq 10\text{mm}$ )			$0.25 < \Phi \leq 0.35$	3			$\Phi > 0.4$	0		
		Zone Size (mm)	Acceptable Qty																								
			A	B	C																						
		$\Phi \leq 0.10$	Ignore																								
$0.10 < \Phi \leq 0.25$	4( distance $\geq 10\text{mm}$ )																										
$0.25 < \Phi \leq 0.35$	3																										
$\Phi > 0.4$	0																										
② Dim spot (LCD/TP/Polarizer dim dot, light leakage, dark spot)																											
<table border="1"> <thead> <tr> <th rowspan="2">Zone Size (mm)</th> <th colspan="3">Acceptable Qty</th> </tr> <tr> <th>A</th> <th>B</th> <th>C</th> </tr> </thead> <tbody> <tr> <td><math>\Phi \leq 0.1</math></td> <td colspan="3">Ignore</td> </tr> <tr> <td><math>0.10 &lt; \Phi \leq 0.25</math></td> <td colspan="3">4( distance <math>\geq 10\text{mm}</math>)</td> </tr> <tr> <td><math>0.25 &lt; \Phi \leq 0.35</math></td> <td colspan="3">3</td> </tr> <tr> <td><math>\Phi &gt; 0.4</math></td> <td colspan="3">0</td> </tr> </tbody> </table>			Zone Size (mm)	Acceptable Qty			A	B	C	$\Phi \leq 0.1$	Ignore			$0.10 < \Phi \leq 0.25$	4( distance $\geq 10\text{mm}$ )			$0.25 < \Phi \leq 0.35$	3			$\Phi > 0.4$	0				
Zone Size (mm)	Acceptable Qty																										
	A	B	C																								
$\Phi \leq 0.1$	Ignore																										
$0.10 < \Phi \leq 0.25$	4( distance $\geq 10\text{mm}$ )																										
$0.25 < \Phi \leq 0.35$	3																										
$\Phi > 0.4$	0																										
③ Polarizer accidented spot																											
<table border="1"> <thead> <tr> <th rowspan="2">Zone Size (mm)</th> <th colspan="3">Acceptable Qty</th> </tr> <tr> <th>A</th> <th>B</th> <th>C</th> </tr> </thead> <tbody> <tr> <td><math>\Phi \leq 0.2</math></td> <td colspan="3">Ignore</td> </tr> <tr> <td><math>0.3 &lt; \Phi \leq 0.5</math></td> <td colspan="3">3( distance <math>\geq 10\text{mm}</math>)</td> </tr> <tr> <td><math>\Phi &gt; 0.5</math></td> <td colspan="3">1</td> </tr> </tbody> </table>			Zone Size (mm)	Acceptable Qty			A	B	C	$\Phi \leq 0.2$	Ignore			$0.3 < \Phi \leq 0.5$	3( distance $\geq 10\text{mm}$ )			$\Phi > 0.5$	1								
Zone Size (mm)	Acceptable Qty																										
	A	B	C																								
$\Phi \leq 0.2$	Ignore																										
$0.3 < \Phi \leq 0.5$	3( distance $\geq 10\text{mm}$ )																										
$\Phi > 0.5$	1																										
④ Pixel bad points (light dot, Dim dot, color dot)																											
<table border="1"> <thead> <tr> <th rowspan="2">Zone Size (mm)</th> <th colspan="3">Acceptable Qty</th> </tr> <tr> <th>A</th> <th>B</th> <th>C</th> </tr> </thead> <tbody> <tr> <td><math>\Phi \leq 0.15</math></td> <td colspan="3">Ignore</td> </tr> <tr> <td><math>0.2 &lt; \Phi \leq 0.3</math></td> <td colspan="3">2( distance <math>\geq 10\text{mm}</math>)</td> </tr> <tr> <td><math>\Phi &gt; 0.4</math></td> <td colspan="3">1</td> </tr> </tbody> </table>			Zone Size (mm)	Acceptable Qty			A	B	C	$\Phi \leq 0.15$	Ignore			$0.2 < \Phi \leq 0.3$	2( distance $\geq 10\text{mm}$ )			$\Phi > 0.4$	1								
Zone Size (mm)	Acceptable Qty																										
	A	B	C																								
$\Phi \leq 0.15$	Ignore																										
$0.2 < \Phi \leq 0.3$	2( distance $\geq 10\text{mm}$ )																										
$\Phi > 0.4$	1																										
⑤ Polarizer Bubble																											
<table border="1"> <thead> <tr> <th rowspan="2">Zone Size (mm)</th> <th colspan="3">Acceptable Qty</th> </tr> <tr> <th>A</th> <th>B</th> <th>C</th> </tr> </thead> <tbody> <tr> <td><math>\Phi \leq 0.2</math></td> <td colspan="3">Ignore</td> </tr> <tr> <td><math>0.3 &lt; \Phi \leq 0.4</math></td> <td colspan="3">4(distance <math>\geq 10\text{mm}</math>)</td> </tr> <tr> <td><math>0.4 &lt; \Phi \leq 0.5</math></td> <td colspan="3">3</td> </tr> <tr> <td><math>\Phi &gt; 0.5</math></td> <td colspan="3">1</td> </tr> </tbody> </table>			Zone Size (mm)	Acceptable Qty			A	B	C	$\Phi \leq 0.2$	Ignore			$0.3 < \Phi \leq 0.4$	4(distance $\geq 10\text{mm}$ )			$0.4 < \Phi \leq 0.5$	3			$\Phi > 0.5$	1				
Zone Size (mm)	Acceptable Qty																										
	A	B	C																								
$\Phi \leq 0.2$	Ignore																										
$0.3 < \Phi \leq 0.4$	4(distance $\geq 10\text{mm}$ )																										
$0.4 < \Phi \leq 0.5$	3																										
$\Phi > 0.5$	1																										



3.0	Line defect (LCD/TP /Polarizer backlight black/white line, scratch, stain)	Width(mm)	Length(m m)	Acceptable Qty		
				A	B	C
		$\Phi \leq 0.05$	Ignore	Ignore		
		$0.05 < W \leq 0.06$	$L \leq 5.0$	$N \leq 3$		
		$0.07 < W \leq 0.08$	$L \leq 4.0$	$N \leq 2$		
	$0.08 < W$	Define as spot defect				
4.0	Electronic Comp onents SMT	Not allow missing parts, solderless connection, cold solder joint, mis match, The positive and negative polarity opposite				
5.0	Display color& B rightness	1. Color: Measuring the color coordinates, The measurement standar d according to the datasheet or samples. 2. Brightness: Measuring the brightness of White screen, The measu rement standard according to the datasheet or Samples.				

6.0	RTP Related	TP film bubble/ accident ed spot	Size $\Phi$ (mm)	Acceptable Qty			
				A	B	C	
			$\Phi \leq 0.1$	Ignore			
			$0.1 < \Phi \leq 0.25$	4 (distance $\geq 10$ mm)			
			$0.25 < \Phi \leq 0.35$	3			
			$\Phi > 0.4$	1			
		TP film scratch	Width(mm)	Length( mm)	Acceptable Qty		
					A	B	C
			$\Phi \leq 0.05$	Ignore	Ignore		
			$0.05 < W \leq 0.06$	$L \leq 5.0$	$N \leq 3$		
$0.07 < W \leq 0.08$	$L \leq 4.0$		$N \leq 2$				
	$0.08 < W$	Define as spot defect					

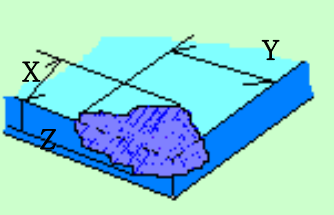

		<p>Assembly deflection</p>	<p>beyond the edge of backlight <math>\leq 0.2\text{mm}</math></p>							
		<p>Bulge (undulation included)</p>	<p>The ITO film plumped below 0.40mm, it's ok.</p> 							
		<p>Newton Ring</p>	<p>Newton Ring area <math>&gt; 1/3</math> TP area NG</p> <p>Newton Ring area <math>\leq 1/3</math> TP area OK</p>							
		<p>TP corner broken</p> <p>X : length</p> <p>Y : width</p> <p>Z : height</p>	<table border="1" data-bbox="710 1489 1141 1668"> <thead> <tr> <th>X</th> <th>Y</th> <th>Z</th> </tr> </thead> <tbody> <tr> <td><math>X \leq 3\text{mm}</math></td> <td><math>Y \leq 3\text{mm}</math></td> <td><math>Z &lt; \text{COVER thickness}</math> s</td> </tr> </tbody> </table> <p>*Circuitry broken is not allowed.</p>	X	Y	Z	$X \leq 3\text{mm}$	$Y \leq 3\text{mm}$	$Z < \text{COVER thickness}$ s	
X	Y	Z								
$X \leq 3\text{mm}$	$Y \leq 3\text{mm}$	$Z < \text{COVER thickness}$ s								



		TP edge broken X : length Y : width Z : height	X	Y	Z	
			X≤4mm	Y≤2mm	Z<COVER thickness	
			* Circuitry broken is not allowed.			

Criteria ( functional items)

Number	Items	Criteria (mm)
1	No display	Not allowed
2	Missing segment	Not allowed
3	Short	Not allowed
4	Backlight no lighting	Not allowed
5	TP no function	Not allowed

ISO9001 : 2008

ISO/TS16949 : 2009



## 8. Reliability Test Result

Item	Condition	Inspection after test
High Temperature Operating	85℃,96H	Inspection after 2~4hours storage at room temperature, the sample shall be free from defects: 1.Air bubble in the LCD; 2.Non-display; 3.Missing segments/line; 4.Glass crack; 5.Current IDD is twice higher than initial value.
Low Temperature Operating	-30℃, 96HR	
High Temperature Storage	90℃, 96HR	
Low Temperature Storage	-40℃, 96HR	
High Temperature & High Humidity Storage	+60℃, 90% RH ,96 hours.	
Thermal Shock (Non-operation)	-40℃,30 min ↔ 90℃,30 min, Change time:5min 20CYC.	
ESD test	C=150pF, R=330,5points/panel Air:±8KV, 5times; Contact:±6KV, 5 times; (Environment: 15℃~35℃, 30%~60%).	
Vibration (Non-operation)	Frequency range:10~55Hz, Stroke:1.5mm Sweep:10Hz~55Hz~10Hz 2 hours for each direction of X.Y.Z. (6 hours for total) (Package condition).	
Box Drop Test	1 Corner 3 Edges 6 faces,80cm(MEDIUM BOX)	

Remark:

- 1.The test samples should be applied to only one test item.
- 2.Sample size for each test item is 5~10pcs.
- 3.For Damp Proof Test, Pure water(Resistance > 10MΩ) should be used.
- 4.In case of malfunction defect caused by ESD damage, if it would be recovered to normal state after resetting, it would be judged as a good part.
- 5.Failure Judgment Criterion: Basic Specification, Electrical Characteristic, Mechanical Characteristic, Optical Characteristic.

Part. No	KD070WVFLA011	REV	V1.0	Page 24 of 26
----------	---------------	-----	------	---------------

常备库存  
Stock For Sale

长期供货  
Long Time supply

支持少量  
NO MOQ

品种齐全  
In Full Range





## 9. Cautions and Handling Precautions

### 9.1 Handling and Operating the Module

- (1) When the module is assembled, it should be attached to the system firmly.  
Do not warp or twist the module during assembly work.
- (2) Protect the module from physical shock or any force. In addition to damage, this may cause improper operation or damage to the module and back-light unit.
- (3) Note that polarizer is very fragile and could be easily damaged. Do not press or scratch the surface.
- (4) Do not allow drops of water or chemicals to remain on the display surface.  
If you have the droplets for a long time, staining and discoloration may occur.
- (5) If the surface of the polarizer is dirty, clean it using some absorbent cotton or soft cloth.
- (6) The desirable cleaners are water, IPA (Isopropyl Alcohol) or Hexane.  
Do not use ketene type materials (ex. Acetone), Ethyl alcohol, Toluene, Ethyl acid or Methyl chloride. It might permanent damage to the polarizer due to chemical reaction.
- (7) If the liquid crystal material leaks from the panel, it should be kept away from the eyes or mouth. In case of contact with hands, legs, or clothes, it must be washed away thoroughly with soap.
- (8) Protect the module from static; it may cause damage to the CMOS ICs.
- (9) Use finger-stalls with soft gloves in order to keep display clean during the incoming inspection and assembly process.
- (10) Do not disassemble the module.
- (11) Protection film for polarizer on the module shall be slowly peeled off just before use so that the electrostatic charge can be minimized.
- (12) Pins of I/F connector shall not be touched directly with bare hands.
- (13) Do not connect, disconnect the module in the "Power ON" condition.
- (14) Power supply should always be turned on/off by the item 6.1 Power On Sequence & 6.2 Power Off Sequence

### 9.2 Storage and Transportation.

- (1) Do not leave the panel in high temperature, and high humidity for a long time.  
It is highly recommended to store the module with temperature from 0 to 35 °C and relative humidity of less than 70%
- (2) Do not store the TFT-LCD module in direct sunlight.
- (3) The module shall be stored in a dark place. When storing the modules for a long time, be sure to adopt effective measures for protecting the modules from strong ultraviolet radiation, sunlight, or fluorescent light.
- (4) It is recommended that the modules should be stored under a condition where no condensation is allowed. Formation of dewdrops may cause an abnormal operation or a failure of the module.  
In particular, the greatest possible care should be taken to prevent any module from being operated where condensation has occurred inside.
- (5) This panel has its circuitry FPC on the bottom side and should be handled carefully in order not to be stressed.

Part. No	KD070WVFLA011	REV	V1.0	Page 25 of 26
----------	---------------	-----	------	---------------

常备库存  
Stock For Sale

长期供货  
Long Time supply

支持小量  
NO MOQ

品种齐全  
In Full Range



10. Packing

---TBD-----

ISO9001 : 2008 ISO/TS16949 : 2009

Part. No	KD070WVFLA011	REV	V1.0	Page 26 of 26
	常备库存 Stock For Sale	长期供货 Long Time supply	支持小量 NO MOQ	品种齐全 In Full Range