

HIGH SPEED SWITCHING.

#### FEATURES

- Low Forward Voltage :  $V_F=0.25(\text{Typ.}) @ I_F=5\text{mA}$
- Small Package : ESM.

#### MAXIMUM RATING (Ta=25 °C)

CHARACTERISTIC	SYMBOL	RATING	UNIT
Maximum (Peak) Reverse Voltage	$V_{RM}$	15	V
Reverse Voltage	$V_R$	10	V
Maximum (Peak) Forward Current	$I_{FM}$	100 *	mA
Average Forward Current	$I_O$	50 *	mA
Surge Current (10ms)	$I_{FSM}$	1 *	A
Power Dissipation	$P_D$	100	mW
Junction Temperature	$T_j$	125	
Storage Temperature Range	$T_{stg}$	-55 125	
Operating Temperature Range	$T_{opr}$	-40 100	

\* : Unit Rating. Total Rating=Unit Rating × 1.5

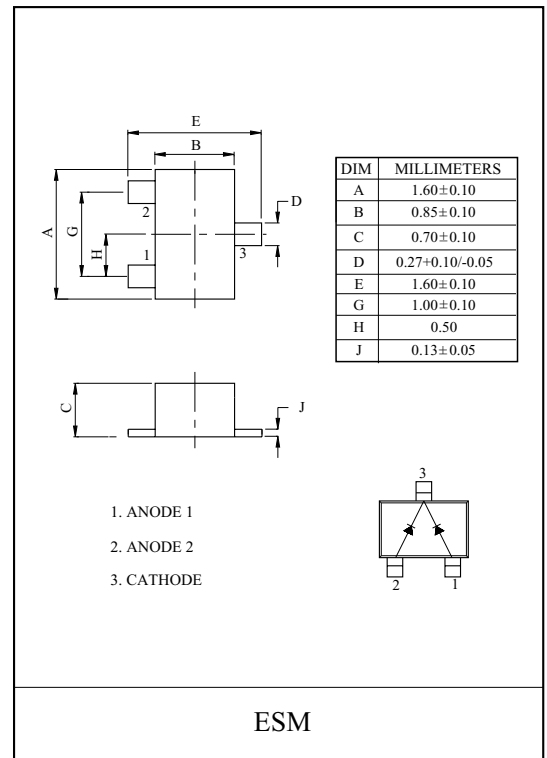

#### Marking

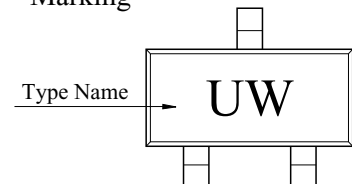

#### ELECTRICAL CHARACTERISTICS (Ta=25 °C)

CHARACTERISTIC	SYMBOL	TEST CONDITION	MIN.	TYP.	MAX.	UNIT
Forward Voltage	$V_{F(1)}$	$I_F=1\text{mA}$	-	0.21	-	V
	$V_{F(2)}$	$I_F=5\text{mA}$	-	0.25	0.30	
	$V_{F(3)}$	$I_F=50\text{mA}$	-	0.35	0.50	
Reverse Current	$I_R$	$V_R=10\text{V}$	-	-	20	μA
Total Capacitance	$C_T$	$V_R=0\text{V}, f=1\text{MHz}$	-	13	40	pF

# KDR331E

$I_F - V_F$

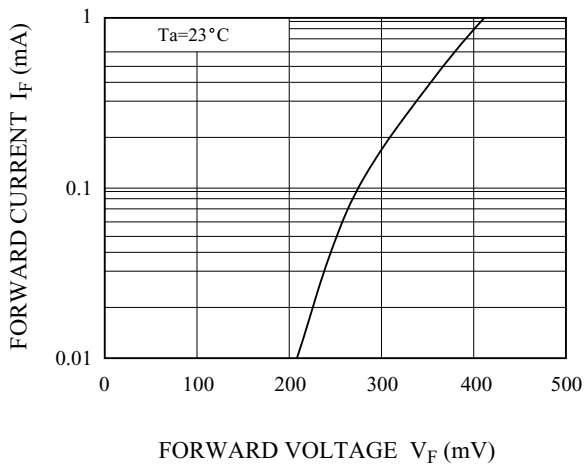

$I_R - V_R$

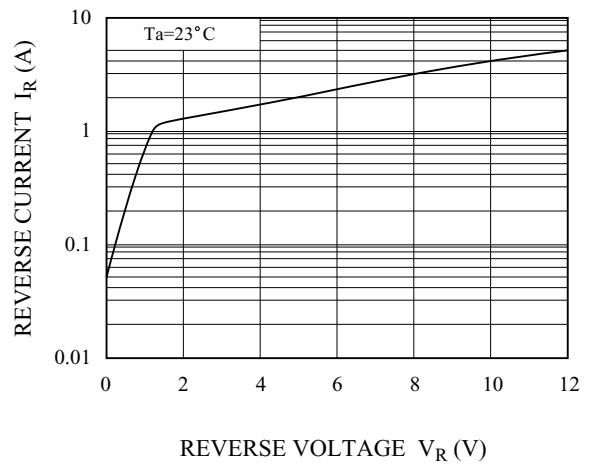

$C_T - V_R$

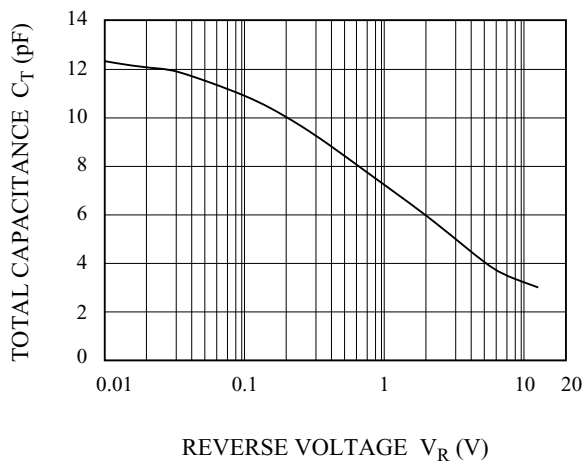

$P - T_a$

