

NPN Digital Transistors

DTC (R1 = R2 Series)ECA (KDTC (R1 = R2 Series)ECA)

■ Features

- Epitaxial Planar Die Construction
- Built-In Biasing Resistors, R1 = R2
- Complementary PNP Types Available

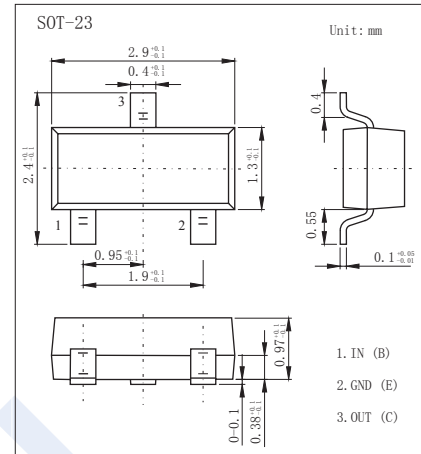
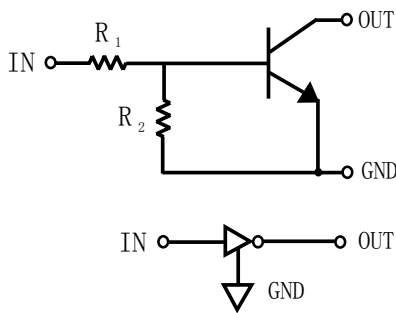

P/N	R1, R2 (NOM)	MARKING
DTC123ECA (KDTC123ECA)	2.2K Ω	N04
DTC143ECA (KDTC143ECA)	4.7K Ω	N08
DTC114ECA (KDTC114ECA)	10K Ω	N13
DTC124ECA (KDTC124ECA)	22K Ω	N17
DTC144ECA (KDTC144ECA)	47K Ω	N20
DTC115ECA (KDTC115ECA)	100K Ω	N24

■ Absolute Maximum Ratings Ta = 25°C

Parameter	Symbol	Rating	Unit
Supply Voltage	V _{CC}	50	
Input Voltage	DTC123ECA	-10 to 20	V
	DTC143ECA	-10 to 30	
	DTC114ECA	-10 to 40	
	DTC124ECA	-10 to 40	
	DTC144ECA	-10 to 40	
	DTC115ECA	-10 to 40	
Output Current	DTC123ECA	100	mA
	DTC143ECA	100	
	DTC114ECA	50	
	DTC124ECA	30	
	DTC144ECA	100	
	DTC115ECA	20	
Output Current All	I _{C(Max)}	100	
Collector Power Dissipation	P _C	200	mW
Thermal Resistance, Junction to Ambient	R _{θJA}	625	°C/W
Junction Temperature	T _J	150	°C
Storage Temperature Range	T _{stg}	-55 to 150	

NPN Digital Transistors

DTC (R1 = R2 Series)ECA (KDTC (R1 = R2 Series)ECA)

■ Electrical Characteristics Ta = 25°C

Parameter		Symbol	Test Conditions	Min	Typ	Max	Unit
Input Voltage		$V_{I(off)}$	$V_{CC}= 5V, I_o= 100\mu A$	0.5	1.1		
Input Voltage	DTC123ECA	$V_{I(on)}$	$V_o= 300mV, I_o= 20mA$		1.9	3	V
	DTC143ECA		$V_o= 300mV, I_o= 20mA$				
	DTC114ECA		$V_o= 300mV, I_o= 10mA$				
	DTC124ECA		$V_o= 300mV, I_o= 5mA$				
	DTC144ECA		$V_o= 300mV, I_o= 2mA$				
	DTC115ECA		$V_o= 300mV, I_o= 1mA$				
Output Voltage	DTC123ECA	$V_{O(on)}$	$I_o=10mA, I_i=0.5mA$		0.1	0.3	
	DTC143ECA		$I_o=10mA, I_i=0.5mA$				
	DTC114ECA		$I_o=10mA, I_i=0.5mA$				
	DTC124ECA		$I_o=10mA, I_i=0.5mA$				
	DTC144ECA		$I_o=10mA, I_i=0.5mA$				
	DTC115ECA		$I_o=10mA, I_i=0.25mA$				
Input Current	DTC123ECA	I_i	$V_i= 5V$			3.8	mA
	DTC143ECA					1.8	
	DTC114ECA					0.88	
	DTC124ECA					0.36	
	DTC144ECA					0.18	
	DTC115ECA					0.15	
Output Current		$I_{O(off)}$	$V_{CC}= 50V, V_i= 0$			0.5	μA
DC Current Gain	DTC123ECA	G_i	$V_o= 5V, I_o=20mA$	20			
	DTC143ECA		$V_o= 5V, I_o=10mA$	20			
	DTC114ECA		$V_o= 5V, I_o=5mA$	30			
	DTC124ECA		$V_o= 5V, I_o=5mA$	56			
	DTC144ECA		$V_o= 5V, I_o=5mA$	68			
	DTC115ECA		$V_o= 5V, I_o=5mA$	82			
Input Resistor (R1) Tolerance		ΔR_1		-30		30	%
Resistance Ratio		R_2 / R_1		0.8		1.2	
Transition frequency		f_T	$V_{CE}= 10V, I_E= -5mA, f=100MHz$		250		MHz

NPN Digital Transistors

DTC (R1 = R2 Series)ECA (KDTC (R1 = R2 Series)ECA)

■ Typical Characteristics

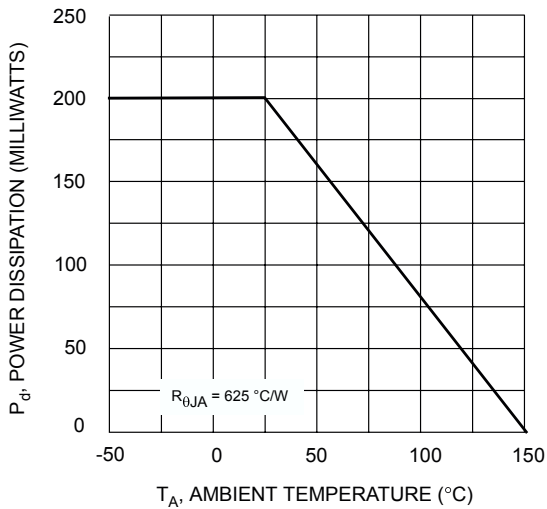

Fig. 1 Derating Curve

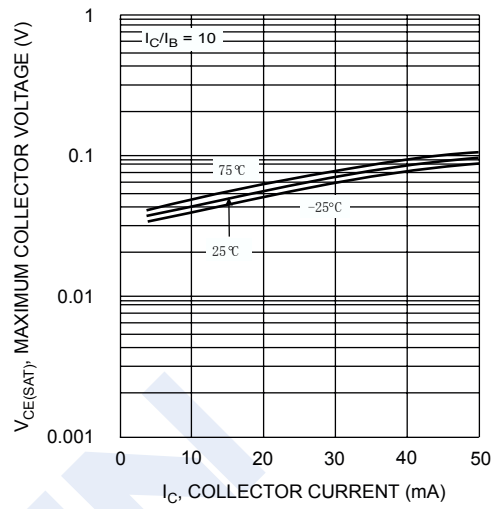

Fig. 2 $V_{CE(SAT)}$ vs. I_C

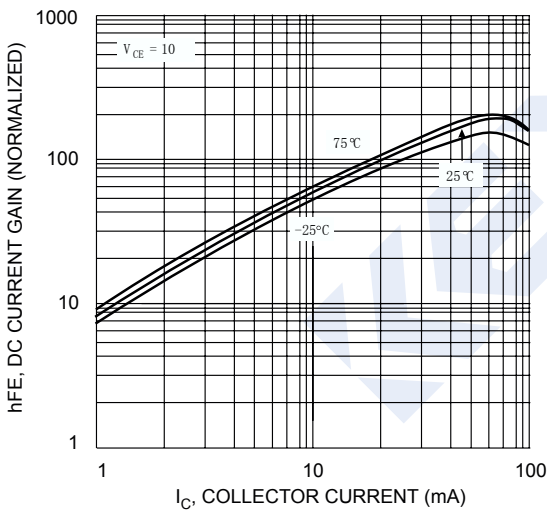

Fig. 3 DC CURRENT GAIN

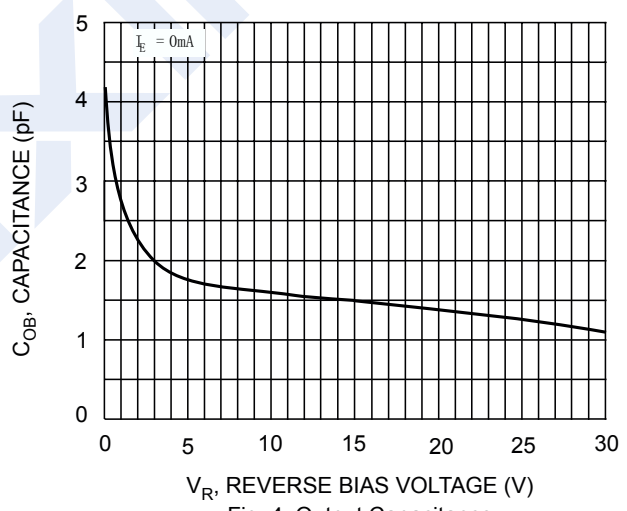

Fig. 4 Output Capacitance

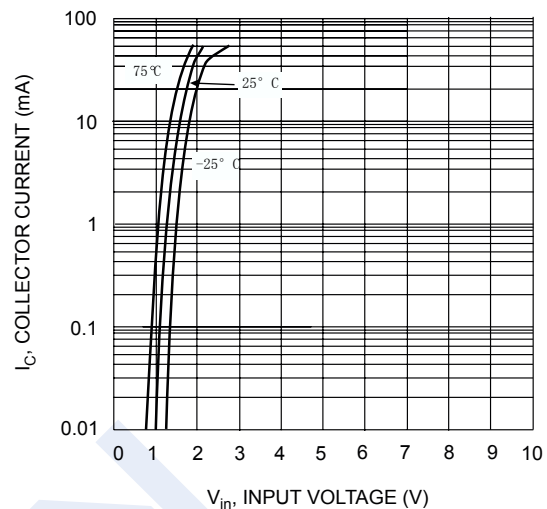

Fig. 5 Collector Current Vs. Input Voltage

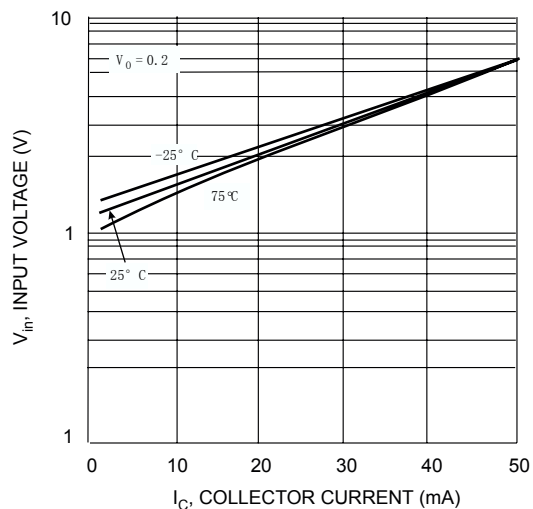

Fig. 6 Input Voltage vs. Collector Current