

Service Manual

PIONEER®
The Art of Entertainment
FIAT

ORDER NO.
CRT2218

HIGH POWER CASSETTE PLAYER WITH RDS TUNER

KEH-2376ZFA X1B/EW

- This additional service manual is designed to be used together with Model KEH-2730R/X1M/EW Service Manual CRT2110. Refer to it for finding parts numbers and adjustment, etc. which are not shown in this manual.

VEHICLE	DESTINATION	PRODUCED AFTER	FIAT PART No.	ID No.	PIONEER MODEL No.
Not specified	EUROPE	May 1998	F-6003R	—	KEH-2376ZFA/X1B/EW

EXPLODED VIEWS AND PARTS LIST

PACKING(Page 2)

● PACKING SECTION PARTS LIST

* : Non Spare Part

Mark	No.	Description	Part No.	
			KEH-2730R/X1M/EW	KEH-2376ZFA/X1B/EW
	2	Accessory Assy	CEA1917	UEA1917
*	6	Polyethylene Bag	E36-615	CEG-127
	7	Polyethylene Bag	CEG-162	UEG-012
	8	Carton	CHG3349	UHG-098
	9	Contain Box	CHL3349	UHL-031
	10	Protector	CHP1622	UHP1622
	11	Protector	CHP1623	UHP1623
	12-1	Owner's Manual	CRD2546	URD-073
	12-2	Owner's Manual	CRD2547	URD-074
	12-3	Installation Manual	CRD2548	URD-075
*	12-4	Warranty Card	CRY1087	URY1087
	13	Case Assy	CXB1063	UXB1063
*		Passport	Not used	CRY1014
*		Caution Card	Not used	URP-002

PIONEER ELECTRONIC CORPORATION 4-1, Meguro 1-Chome, Meguro-ku, Tokyo 153-8654, Japan
PIONEER ELECTRONICS SERVICE INC. P.O.Box 1760, Long Beach, CA 90801-1760 U.S.A.
PIONEER ELECTRONIC [EUROPE] N.V. Haven 1087 Keetberglaan 1, 9120 Melsele, Belgium
PIONEER ELECTRONICS ASIACENTRE PTE.LTD. 501 Orchard Road, #10-00, Wheelock Place, Singapore 238880

www.DataSheet4U.com

© PIONEER ELECTRONIC CORPORATION 1998

K-ZEM. JUNE 1998 Printed in Japan

EXTERIOR(Page 4)

● **EXTERIOR SECTION PARTS LIST**

Mark	No.	Description	Part No.	
			KEH-2730R/X1M/EW	KEH-2376ZFA/X1B/EW
	6	Holder Unit	CXB2687	CNC6798 (Holder)
	13	Tuner Amp Unit	CWM5521	UWM5521
	37	Panel Unit	CXA9848	UXA-045
	41	Case Assy	CXB1063	UXB1063
	42	Detach Grille Assy	CXB1725	UXB-005
	57	Keyboard Unit	CWM5530	UWM-014
	64	Grille Assy	CXB2319	UX-004

ELECTRIKAL PARTS LIST

● **TUNER AMP UNIT(Page 27)**

Circuit Symbol and No.	Part No.	
	KEH-2730R/X1M/EW	KEH-2376ZFA/X1B/EW
C 219,331,419,424,509 — 516	CKSQYB104K16	CKSQYB104K25
C 342,804	CKSQYB473K16	CKSQYB473K25
C 519,520,606,702,706,708	CKSQYB104K16	CKSQYB104K25
C 710,711,809	CKSQYB104K16	CKSQYB104K25

● **KEYBOARD UNIT(Page 31)**

Circuit Symbol and No.	Part No.	
	KEH-2730R/X1M/EW	KEH-2376ZFA/X1B/EW
IL 901,905 Lamp 14V 40mA	CEL1479	CEL1578
IL 902 — 904 Lamp 14V 40mA	CEL1508	CEL1579

Service Manual

PIONEER[®]
The Art of Entertainment

KEH-2700R/X1M/EW

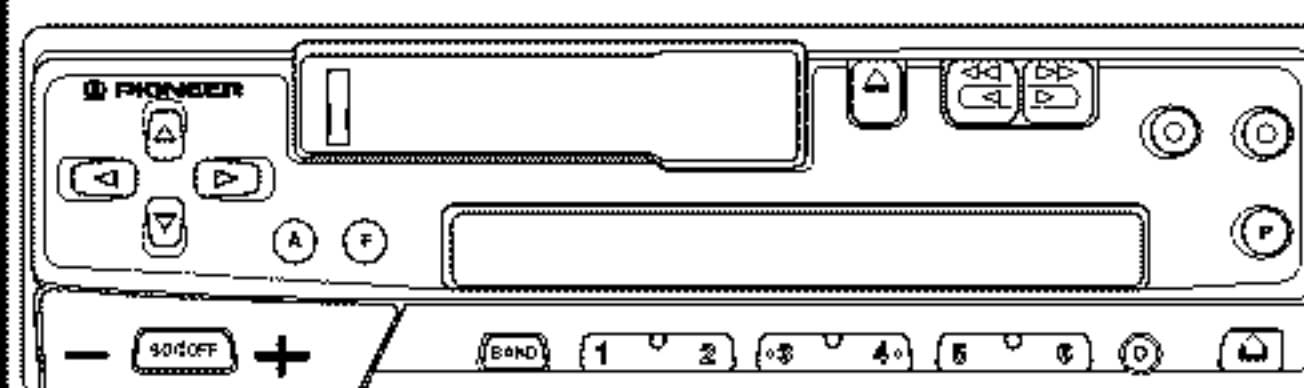

ORDER NO.
CRT2110

HIGH POWER CASSETTE PLAYER WITH RDS TUNER

KEH-2700R X1M/EW

KEH-2730R X1M/EW

NOTE:

- See the separate manual CX-644(CRT1800) for the cassette mechanism description.
- The cassette mechanism assy employed in this model is one of 2M series.
- This service manual has no describe the CD test mode.

For the operations in the CD test mode, refer to the CD player's Service Manual.

CONTENTS

1. SAFETY INFORMATION	2	7. GENERAL INFORMATION	34
2. EXPLODED VIEWS AND PARTS LIST	2	7.1 PARTS	34
3. SCHEMATIC DIAGRAM	10	7.1.1 IC	34
4. PCB CONNECTION DIAGRAM	18	7.1.2 DISPLAY.....	39
5. ELECTRICAL PARTS LIST	26	7.2 DISASSEMBLY	40
6. ADJUSTMENT.....	32	7.3 BLOCK DIAGRAM	41
		8. OPERATIONS AND SPECIFICATIONS.....	42

PIONEER ELECTRONIC CORPORATION 4-1, Meguro 1-Chome, Meguro-ku, Tokyo 153, Japan
PIONEER ELECTRONICS SERVICE INC. P.O.Box 1760, Long Beach, CA 90801-1760 U.S.A.
PIONEER ELECTRONIC [EUROPE] N.V. Haven 1087 Keetberglaan 1, 9120 Melsele, Belgium
PIONEER ELECTRONICS ASIACENTRE PTE.LTD. 501 Orchard Road, #10-00, Weelock Place, Singapore 238880

© PIONEER ELECTRONIC CORPORATION 1997

K-ZEM. NOV.1997 Printed in Belgium

1. SAFETY INFORMATION

This service manual is intended for qualified service technicians; it is not meant for the casual do-it-yourselfer. Qualified technicians have the necessary test equipment and tools, and have been trained to properly and safely repair complex products such as those covered by this manual. Improperly performed repairs can adversely affect the safety and reliability of the product and may void the warranty. If you are not qualified to perform the repair of this product properly and safely, you should not risk trying to do so and refer the repair to a qualified service technician.

2. EXPLODED VIEWS AND PARTS LIST

2.1 PACKING

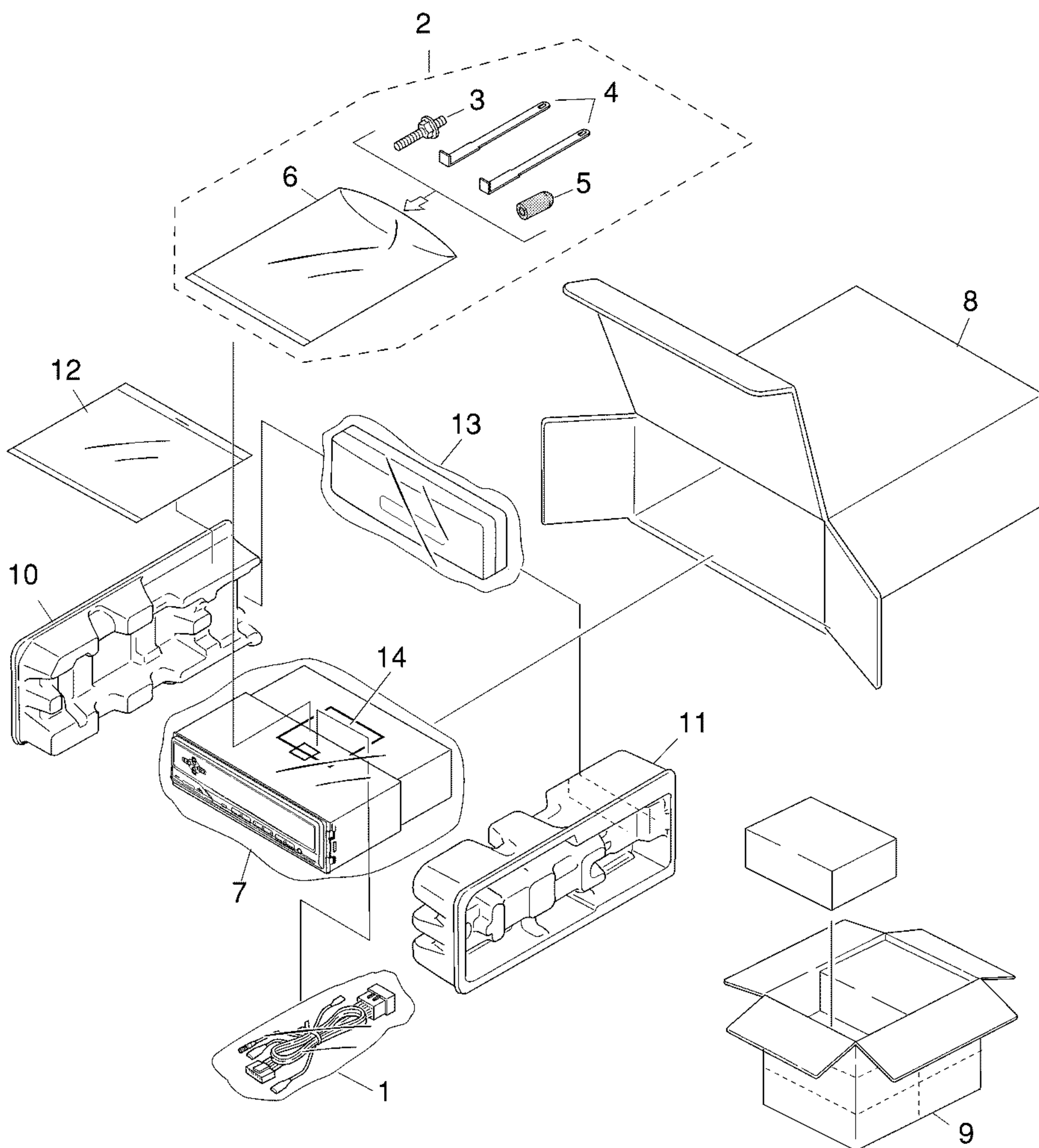

Fig. 1

NOTE:

- Parts marked by “*” are generally unavailable because they are not in our Master Spare Parts List.
- Screws adjacent to ∇ mark on the product are used for disassembly.

● PACKING SECTION PARTS LIST

Mark	No.	Description	Part No.	
			KEH-2700R/X1M/EW	KEH-2730R/X1M/EW
	1	Cord Assy	CDE5498	CDE5498
	2	Accessory Assy	CEA1917	CEA1917
	3	Screw	CBA1304	CBA1304
	4	Handle(x2)	CNC5395	CNC5395
	5	Bush	CNV3930	CNV3930
*	6	Polyethylene Bag	E36-615	E36-615
	7	Polyethylene Bag	CEG-162	CEG-162
	8	Carton	CHG3348	CHG3349
	9	Contain Box	CHL3348	CHL3349
	10	Protector	CHP1622	CHP1622
	11	Protector	CHP1623	CHP1623
	12-1	Owner's Manual	CRD2546	CRD2546
	12-2	Owner's Manual	CRD2547	CRD2547
	12-3	Installation Manual	CRD2548	CRD2548
*	12-4	Warranty Card	CRY1087	CRY1087
	13	Case Assy	CXB1063	CXB1063
*	14	Caution Card	CRP1172	CRP1172

● Owner's Manual, Installation Manual

Part No.	Language
CRD2546	English,Spanish,German
CRD2547	French,Italian,Dutch
CRD2548	English,Spanish,German French,Italian,Dutch

2. EXPLODED VIEWS AND PARTS LIST

2.1 EXTERIOR

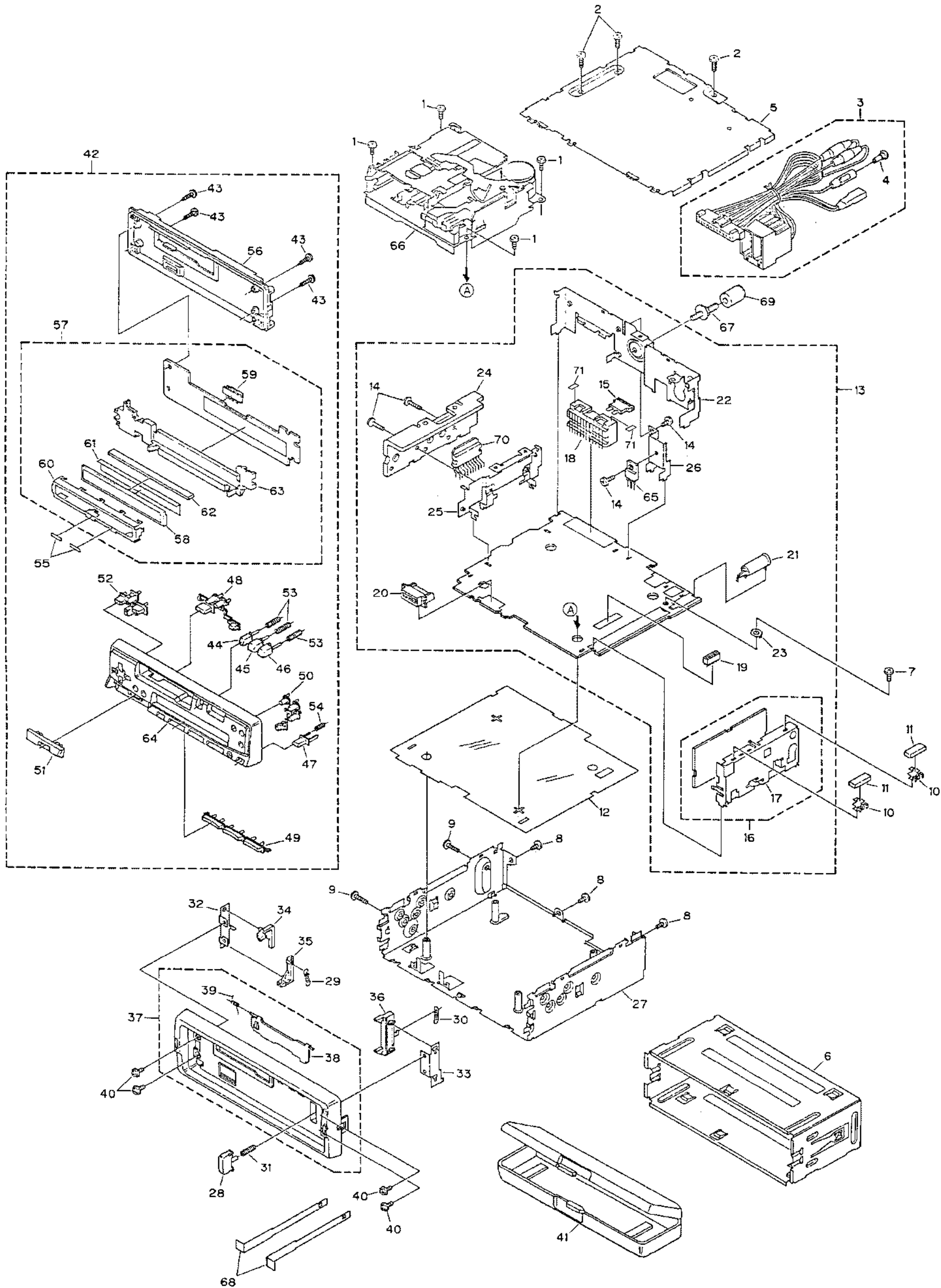

Fig. 2

(1) EXTERIOR SECTION PARTS LIST

Mark No.	Description	Part No.	Mark No.	Description	Part No.
1	Screw	BSZ26P050FMC	36	Arm	CNV4728
2	Screw	BSZ30P100FMC	37	Panel Unit	See Contrast table(2)
3	Cord Assy	CDE5498	38	Door	CAT1814
4	Terminal Cover	CKX-003	39	Spring	CBH1838
5	Case	CNB2074	40	Screw	IMS20P030FZK
6	Holder	CNC6798	41	Case Assy	CXB1063
7	Screw	BSZ30P055FUC	42	Detach Grille Assy	See Contrast table(2)
8	Screw	BSZ30P060FMC	43	Screw	BPZ20P120FZK
9	Screw	BSZ30P100FMC	44	Button(⏏)	CAC4867
10	Holder	CNC5704	45	Button(⏪)	CAC4868
11	Cushion	CNM4870	46	Button(⏩)	CAC4869
12	Insulator	CNM5025	47	Button(⏏)	See Contrast table(2)
13	Tuner Amp Unit	See Contrast table(2)	48	Button	CAC5306
14	Screw	BSZ26P080FMC	49	Button(1-6)	See Contrast table(2)
15	Fuse(10A)	CEK1136	50	Button	See Contrast table(2)
16	FM/AM Tuner Unit	CWE1466	51	Button(DOWN,UP)	See Contrast table(2)
17	Holder	CNC6554	52	Button	See Contrast table(2)
18	Plug(CN601)	CKM1270	53	Spring	CBH1836
19	Connector(CN604)	CKS3362	54	Spring	CBH2103
20	Connector(CN603)	CKS3581	55	Spacer	CNM5319
21	Antenna Jack(CN301)	CKX1056	56	Cover	See Contrast table(2)
22	Panel	CNB2246	57	Keyboard Unit	See Contrast table(2)
23	Holder	CNC5399	58	LCD(LCD901)	CAW1391
24	Heat Sink	CNC6217	59	Connector(CN901)	CKS3580
25	Holder	CNC6372	60	Holder	CNC6846
26	Holder	CNC6845	61	Reflector	CNM5542
27	Chassis Unit	CXA9851	62	Connector	CNV4763
28	Button	CAC4836	63	Lighting Conductor	CNV5074
29	Spring	CBH1834	64	Grille Assy	See Contrast table(2)
30	Spring	CBH1835	65	Transistor(Q801)	2SD2037
31	Spring	CBH1996	66	Cassette Mechanism Assy	EXK3458
32	Bracket	CNC6135	67	Screw	CBA1304
33	Bracket	CNC6791	68	Handle	CNC5395
34	Arm	CNV4692	69	Bush	CNV3930
35	Arm	CNV4693	70	IC(IC501)	HA13155
			71	Spacer	CNM5739

KEH-2700R,2730R

(2) CONTRAST TABLE

KEH-2700R/X1M/EW and KEH-2730R/X1M/EW are constructed the same except for the following:

Mark No.	Symbol and Description	Part No.	
		KEH-2700R/X1M/EW	KEH-2730R/X1M/EW
13	Tuner Amp Unit	CWM5520	CWM5521
37	Panel Unit	CXA9847	CXA9848
42	Detach Grille Assy	CXB1724	CXB1725
47	Button(⏏)	CAC4870	CAC4993
49	Button(1-6)	CAC5307	CAC5324
50	Button	CAC5310	CAC5308
51	Button(DOWN,UP)	CAC5321	CAC5320
52	Button	CAC5323	CAC5322
56	Cover	CNS4627	CNS4628
57	Keyboard Unit	CWM5529	CWM5530
64	Grille Assy	CXB2318	CXB2319

2.2 CASSETTE MECHANISM ASSY

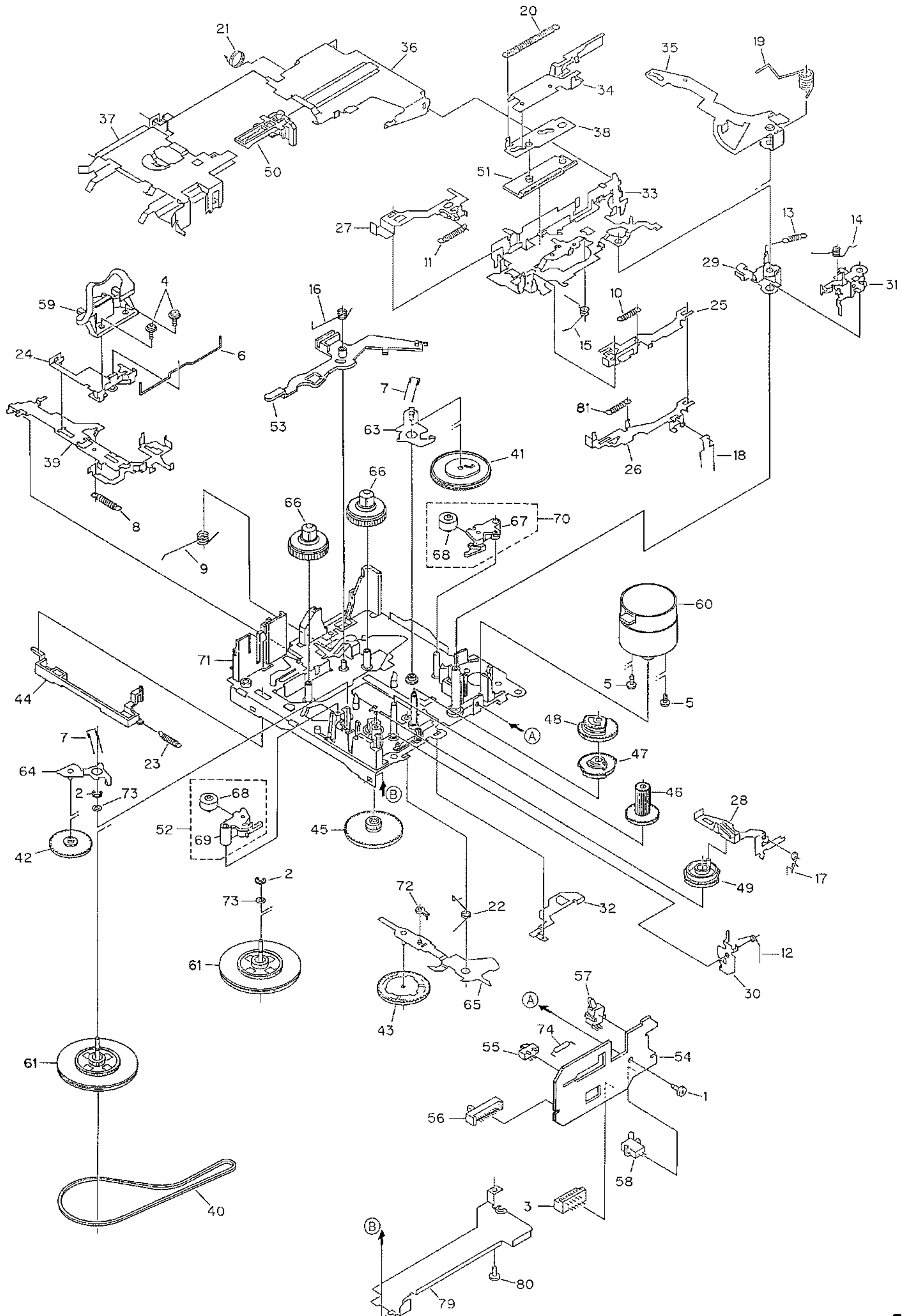

Fig. 3

KEH-2700R,2730R

● CASSETTE MECHANISM ASSY SECTION PARTS LIST

Mark No.	Description	Part No.	Mark No.	Description	Part No.
1	Screw	BSZ23P050FMC	41	Gear	ENV1504
2	Washer	CBG1003	42	Gear	ENV1470
3	Connector(CN1)	CKS2829	43	Gear	ENV1517
4	Screw(M2x5)	EBA1038	44	Lever	ENV1472
5	Screw(M2x2.5)	EBA1037	45	Gear	ENV1510
6	Spring	EBH1554	46	Gear	ENV1475
7	Spring	EBH1555	47	Gear	ENV1512
8	Spring	EBH1556	48	Gear	ENV1513
9	Spring	EBH1557	49	Gear	ENV1502
10	Spring	EBH1591	50	Lever	ENV1480
11	Spring	EBH1559	51	Lever	ENV1487
12	Spring	EBH1593	52	Pinch Holder Unit	EXA1516
13	Spring	EBH1561	53	Arm	ENV1489
14	Spring	EBH1562	* 54	PCB	ENP1161
15	Spring	EBH1563	55	Switch(Eject)(S4)	ESG1006
16	Spring	EBH1590	56	Switch(FWD)(REV)(S3)	ESH1006
17	Spring	EBH1565	57	Switch(Load)(S1)	ESN1016
18	Spring	EBH1566	58	Switch(Mute)(S2)	ESN1017
19	Spring	EBH1567	59	Head Assy(HD1)	EXA1466
20	Spring	EBH1568	60	Motor Unit(M1)	EXA1467
21	Spring	EBH1569	61	Flywheel Unit	EXA1468
22	Spring	EBH1571	62	
23	Spring	EBH1579	63	Arm Unit	EXA1447
24	Head Base	ENC1475	64	Arm Unit	EXA1448
25	Lever	ENC1429	65	Arm Unit	EXA1449
26	Lever	ENC1430	66	Reel Unit	EXA1450
27	Lever	ENC1431	67	Pinch Holder	ENV1466
28	Lever	ENC1432	68	Pinch Roller	ENV1518
29	Arm	ENC1433	69	Pinch Holder	ENV1467
30	Arm	ENC1434	70	Pinch Holder Unit	EXA1515
31	Arm	ENC1480	71	Chassis Unit	EXA1498
32	Arm	ENC1476	72	Service Arm	EXX1048
33	Bracket	ENC1477	73	Washer	HBF-179
34	Lever	ENC1483	74	Resistor(R1)	RD1/4HM472J
35	Arm	ENC1439	75-78	
36	Frame	ENC1440	79	Cover	ENC1452
37	Holder	ENC1441	80	Screw	BSZ23P050FMC
38	Lever	ENC1446	81	Spring	EBH1592
39	Lever	ENC1478			
40	Belt	ENT1027			

3. SCHEMATIC DIAGRAM

3.1 OVERALL CONNECTION DIAGRAM(GUIDE PAGE)

Note: When ordering service parts, be sure to refer to "EXPLODED VIEWS AND PARTS LIST" or "ELECTRICAL PARTS LIST".

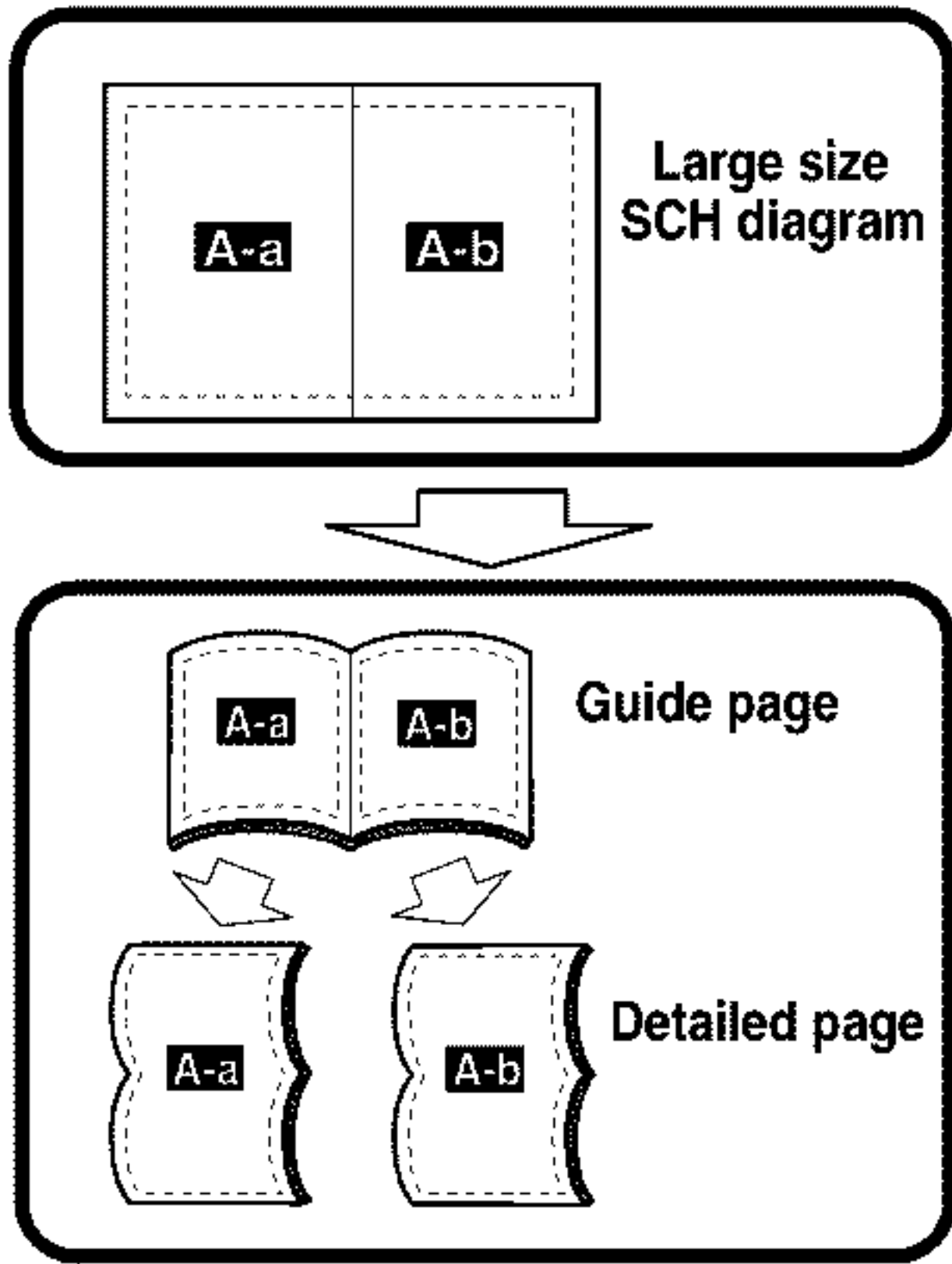

A-a

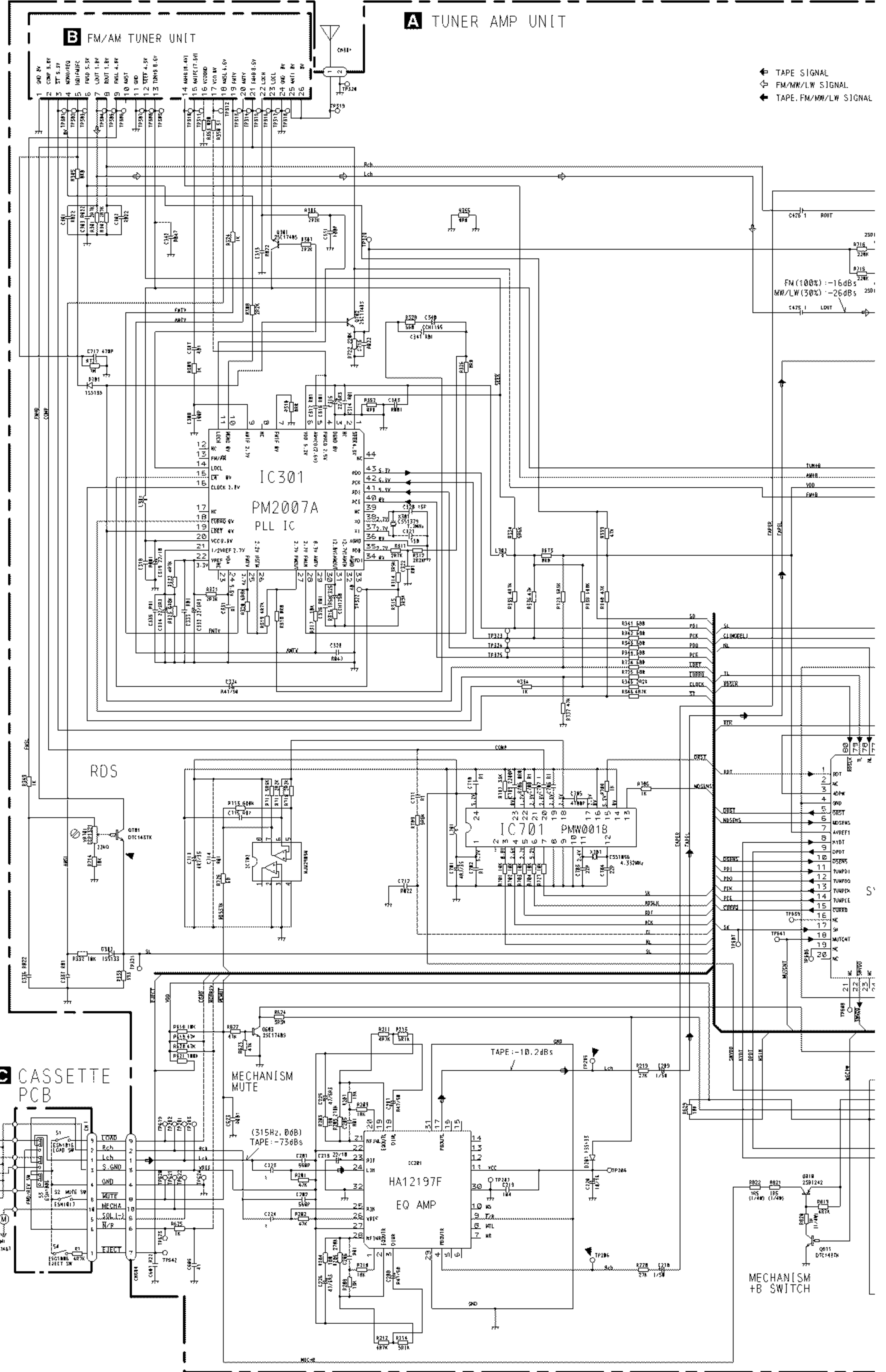

◀ TAPE SIGNAL
 ⊕ FM/MW/LW SIGNAL
 ▶ TAPE FM/MW/LW SIGNAL

C CASSETTE PCB

A TUNER AMP UNIT

B FM/AM TUNER UNIT

10 **A C**

A-b

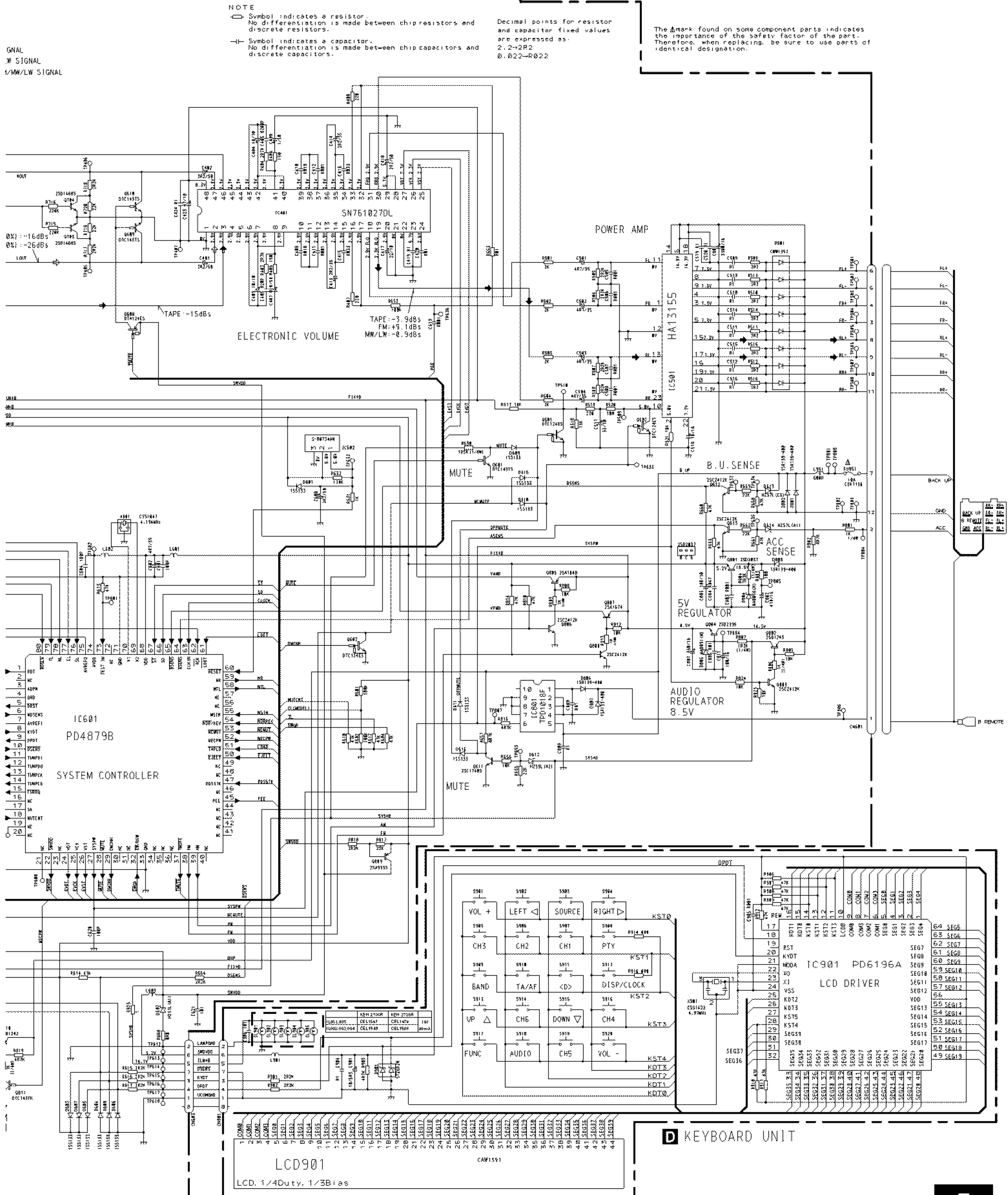
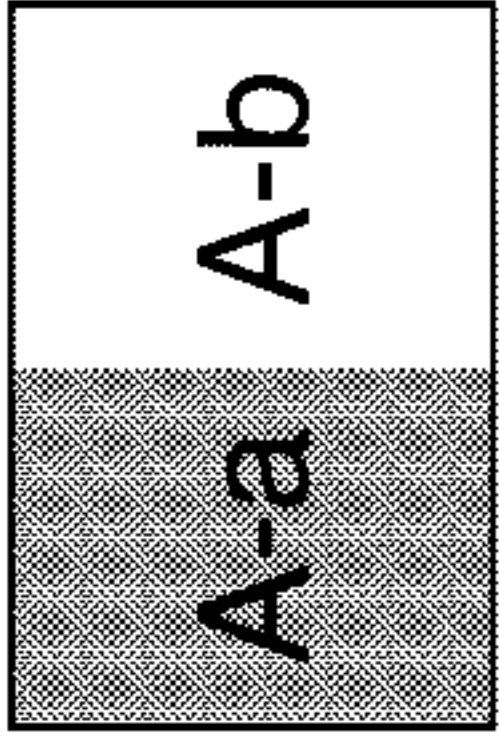

Fig. 4



A TUNER AMP UNIT

B FM/AM TUNER UNIT

- ▶ TAPED SIGNAL
- ◀ FM/MW/LW SIGNAL
- ◀ TAPED, FM/MW/LW SIGNAL

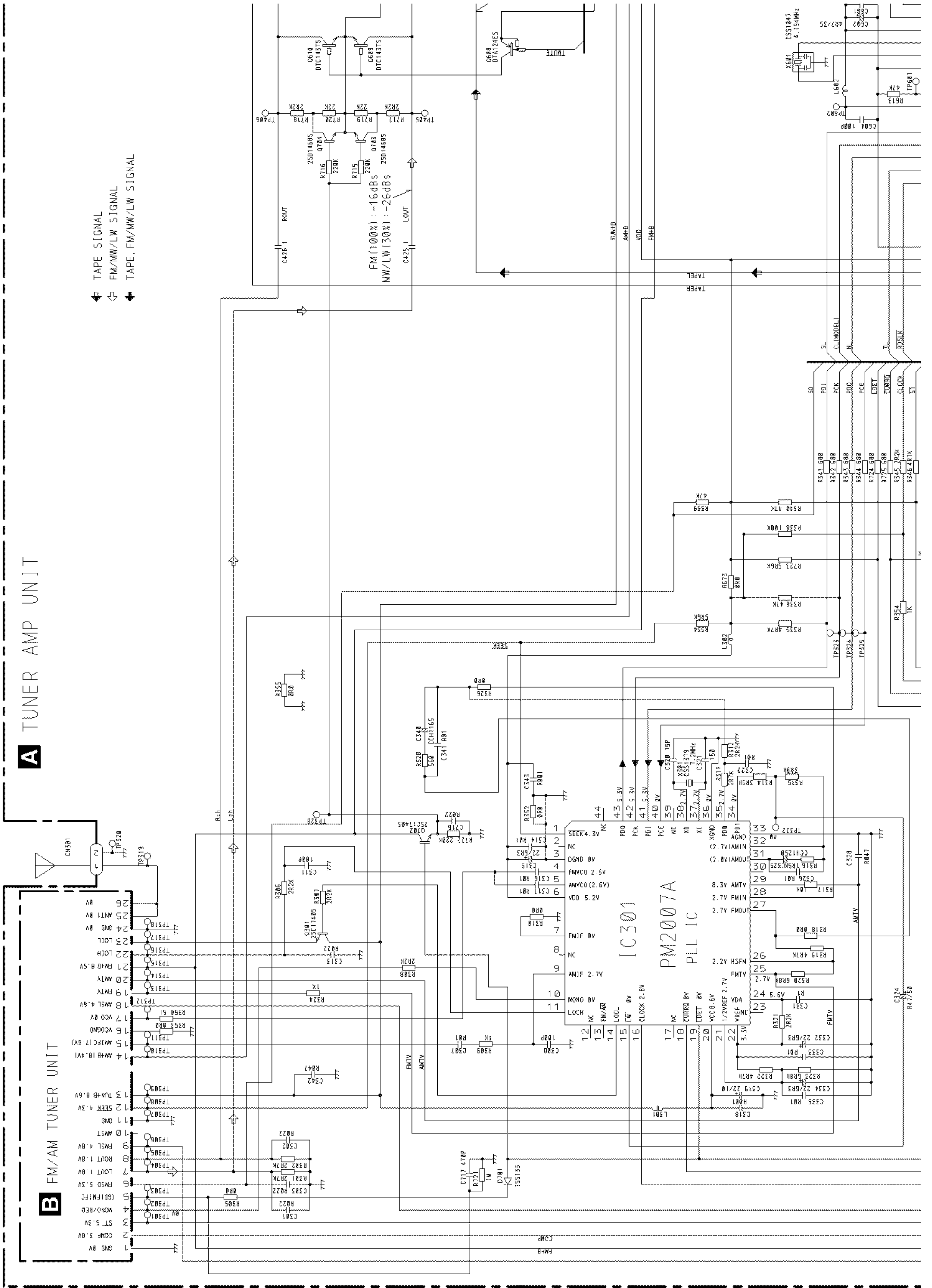

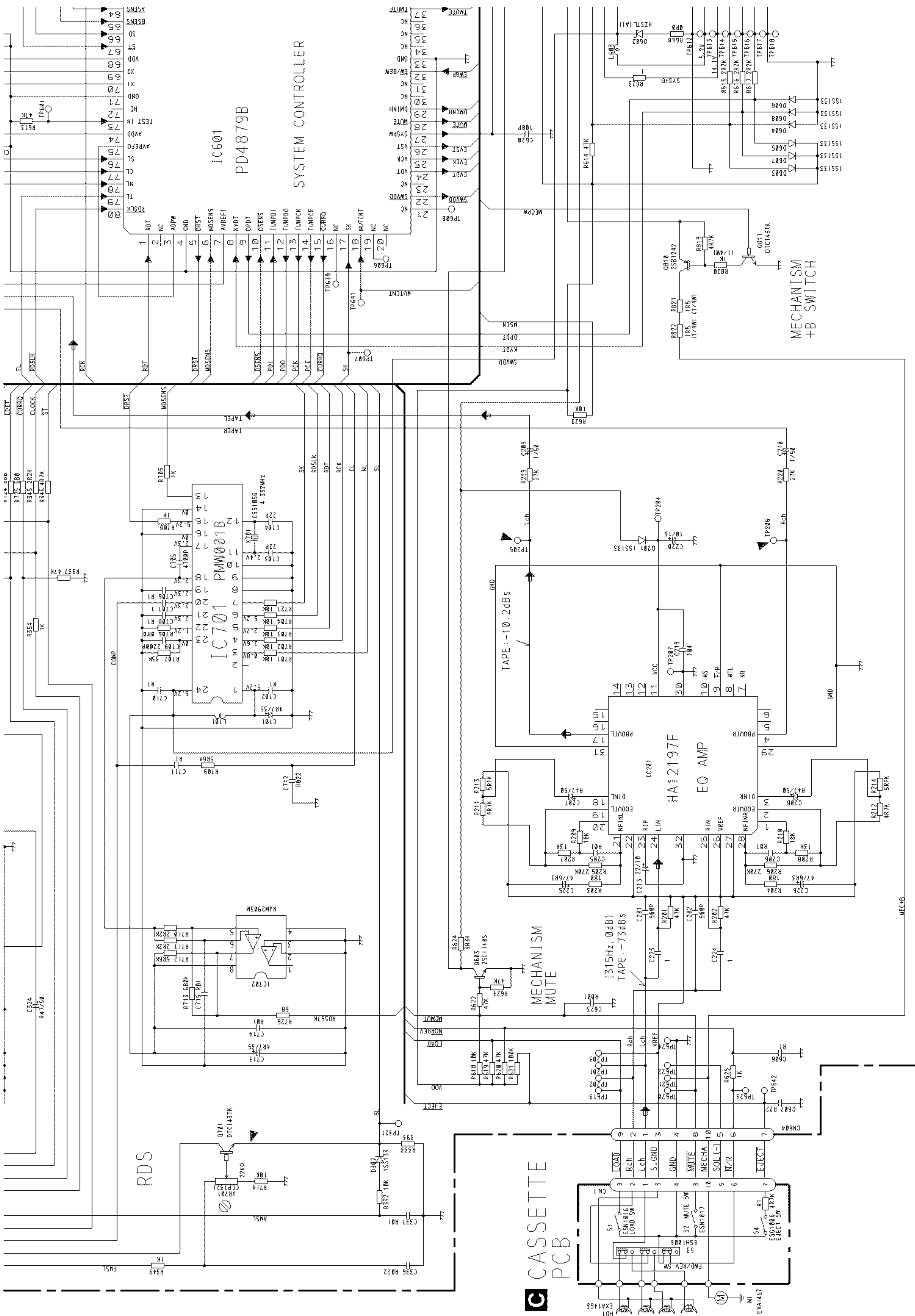

A-a A-b

Fig. 5

C A-a 13

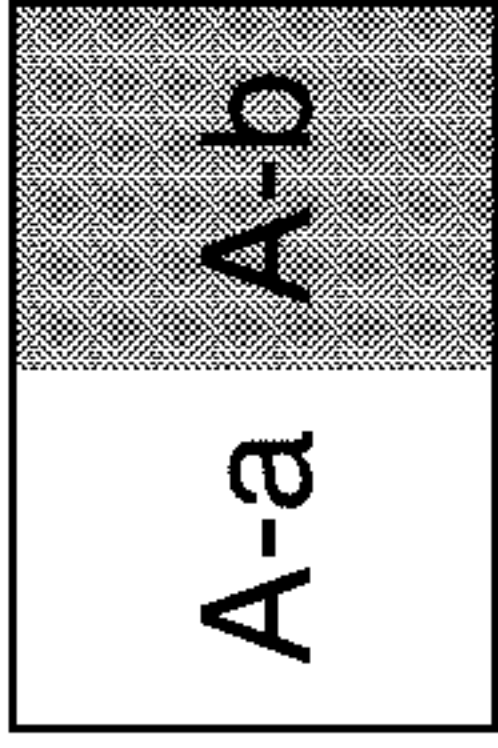

NOTE :
 □ Symbol indicates a resistor.
 No differentiation is made between chip resistors and discrete resistors.
 ▭ Symbol indicates a capacitor.
 No differentiation is made between chip capacitors and discrete capacitors.

Decimal points for resistor and capacitor fixed values are expressed as:
 2.2-2R2
 0.022-R022

The Δ mark found on some component parts indicates the importance of the safety factor of the part. Therefore, when replacing, be sure to use parts of identical designation.

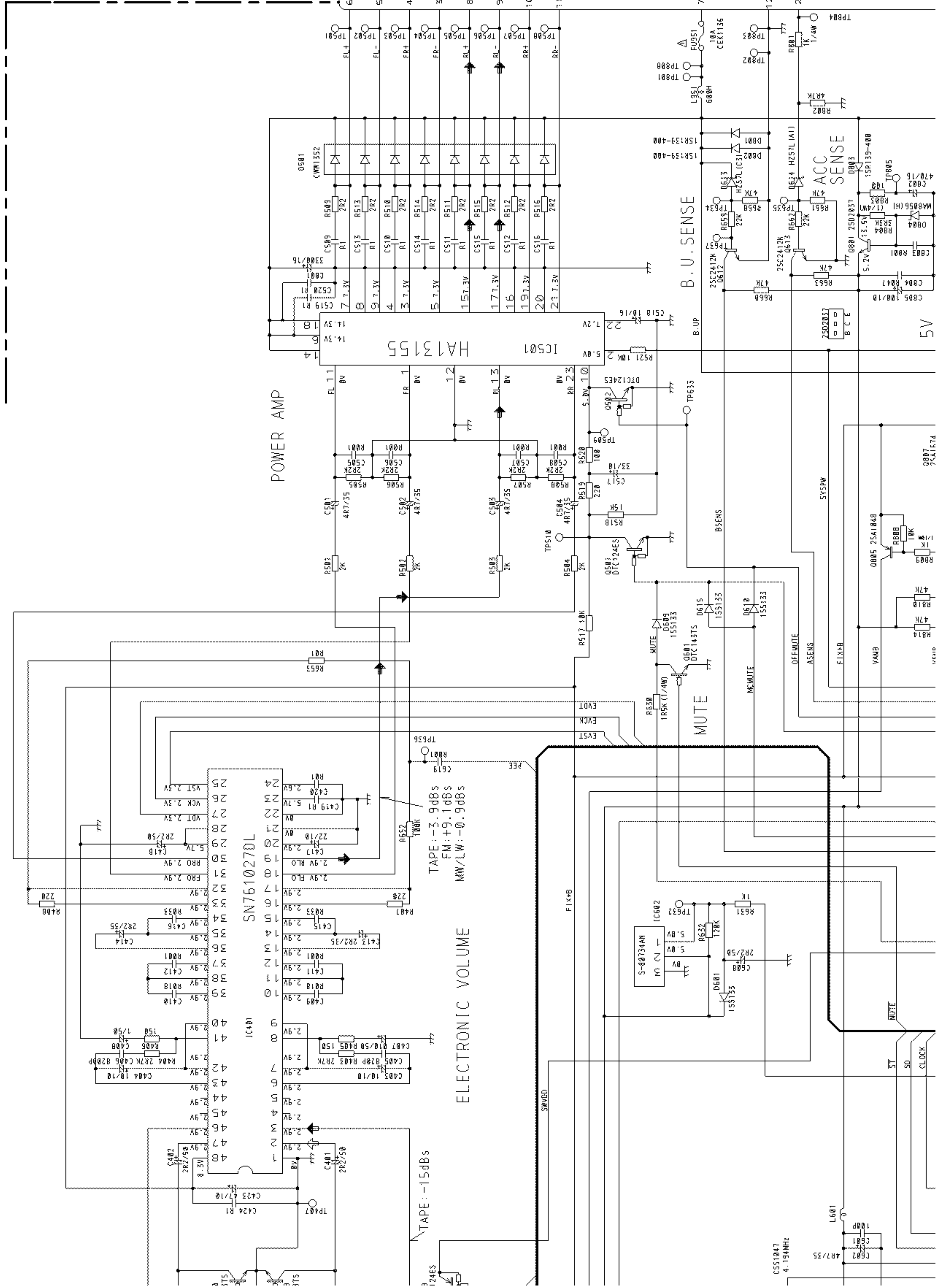

A

B

C

D



A-a A-b

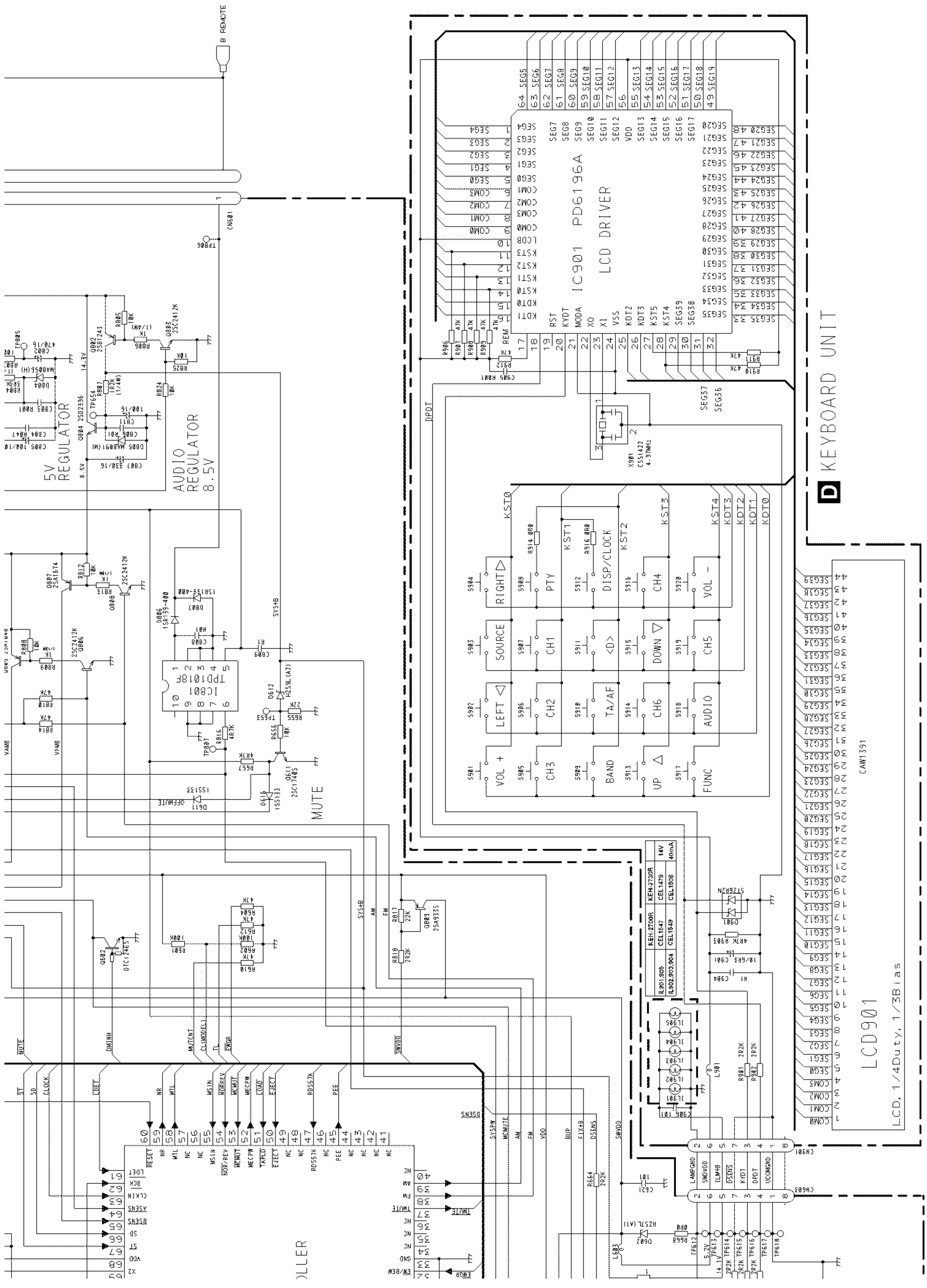
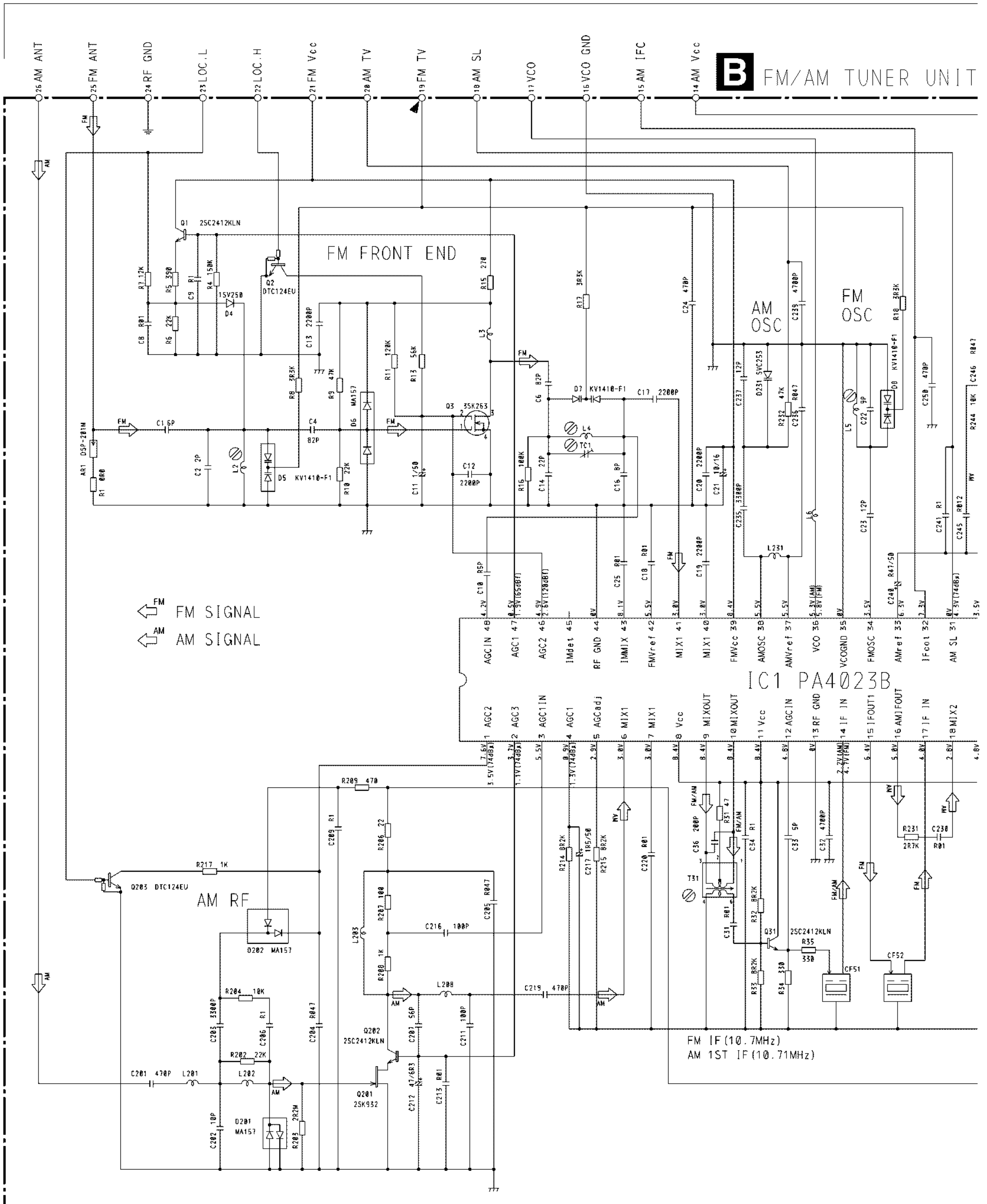

Fig. 6

D A-b

3.2 FM/AM TUNER UNIT

B FM/AM TUNER UNIT



A

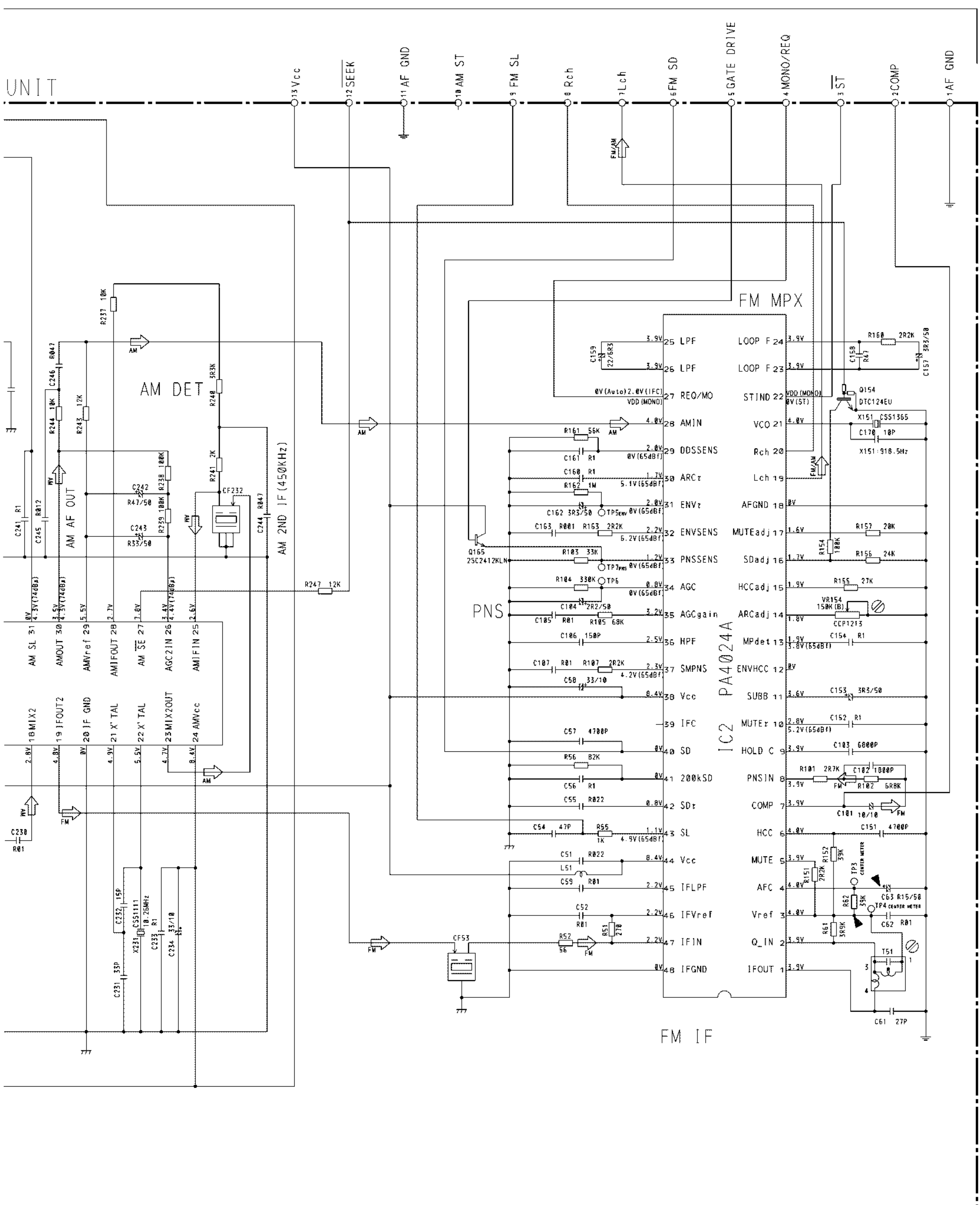

Fig. 7

B

4. PCB CONNECTION DIAGRAM

4.1 TUNER AMP UNIT

NOTE FOR PCB DIAGRAMS

- The parts mounted on this PCB include all necessary parts for several destination.
- For further information for respective destinations, be sure to check with the schematic diagram.
- Viewpoint of PCB diagrams

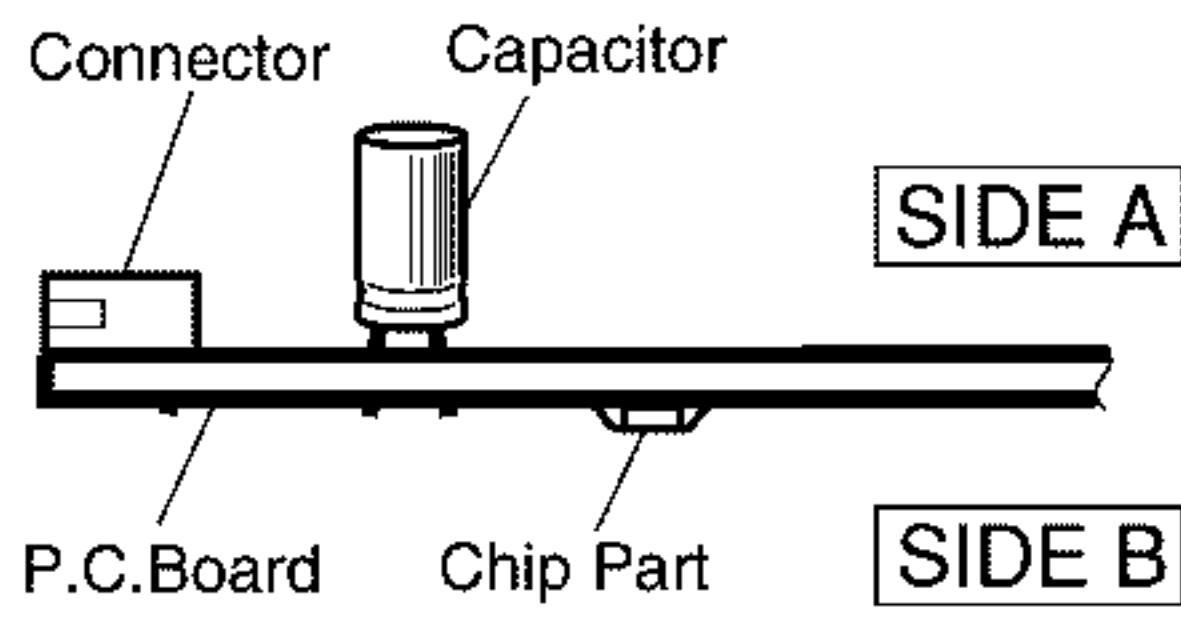

A TUNER AMP UNIT

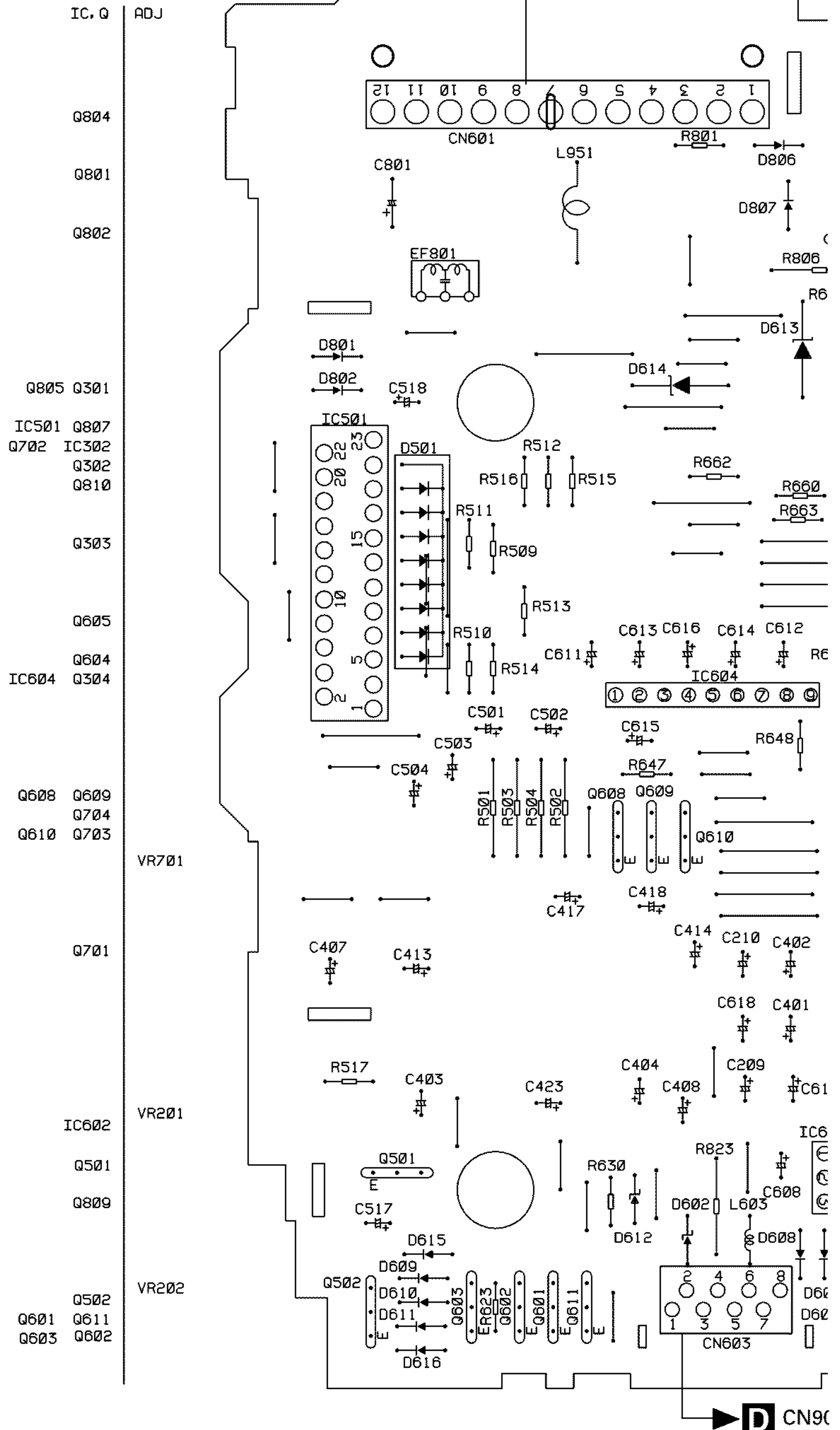

SIDE A

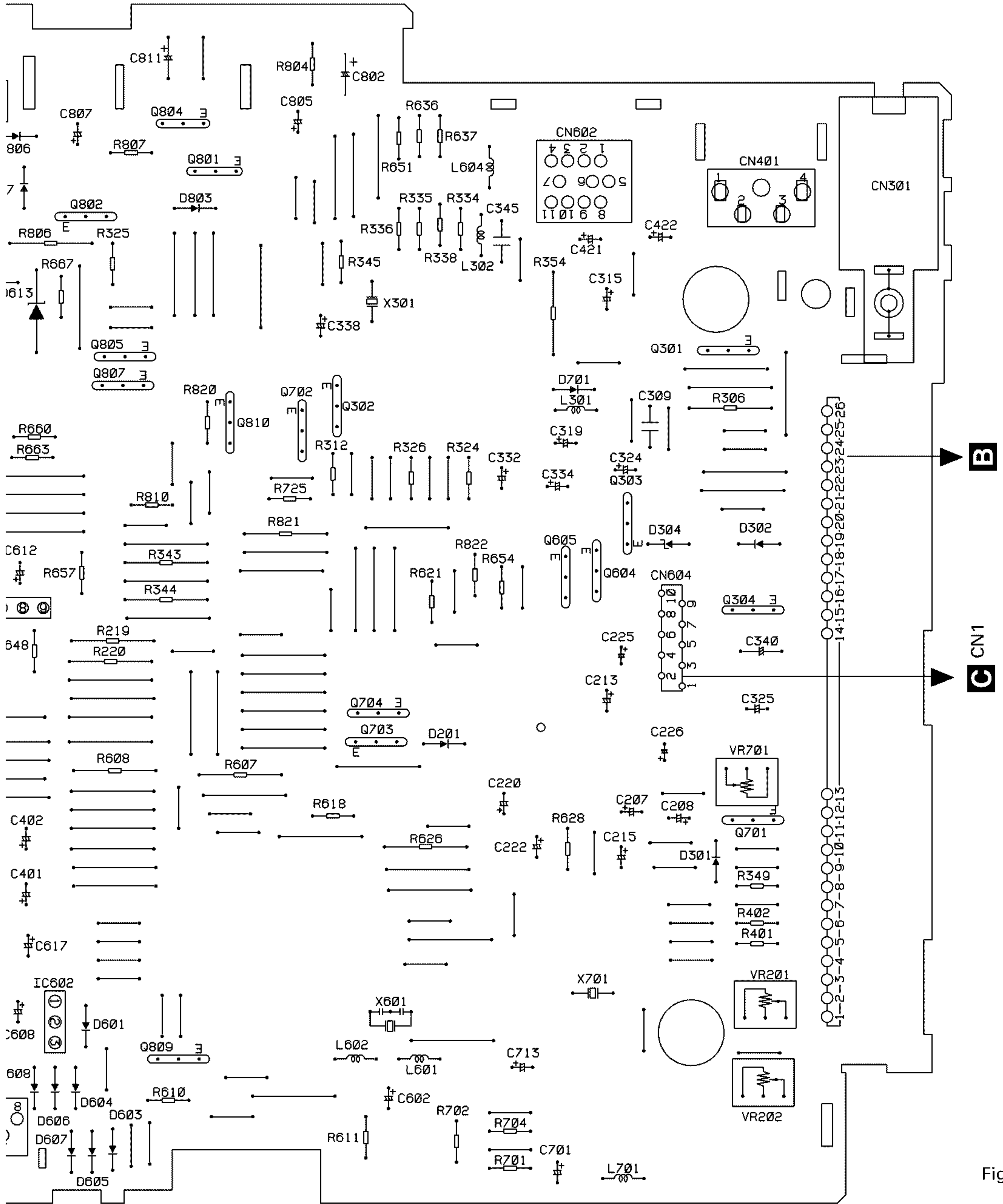
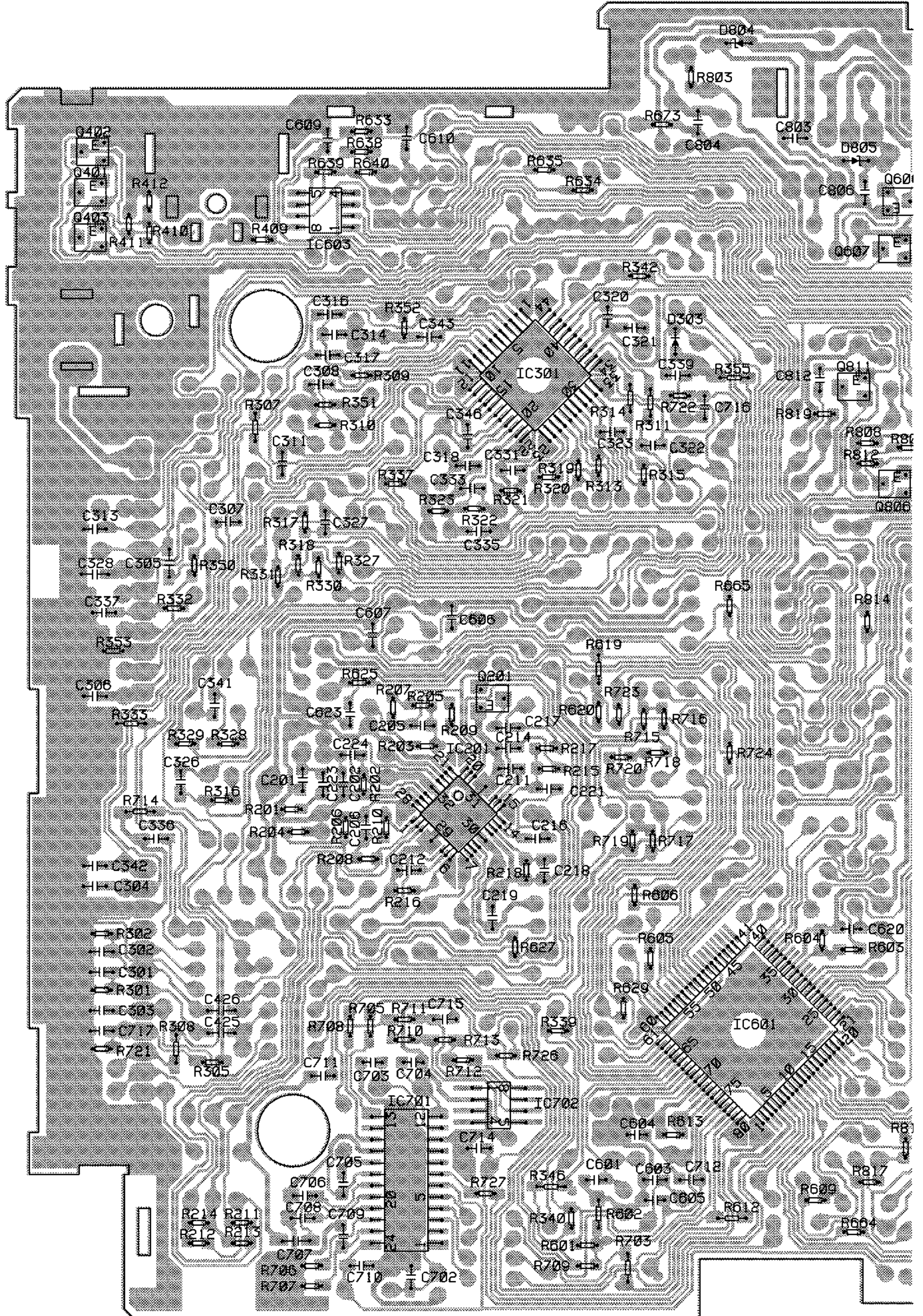

Fig. 8

CN901

A

A TUNER AMP UNIT



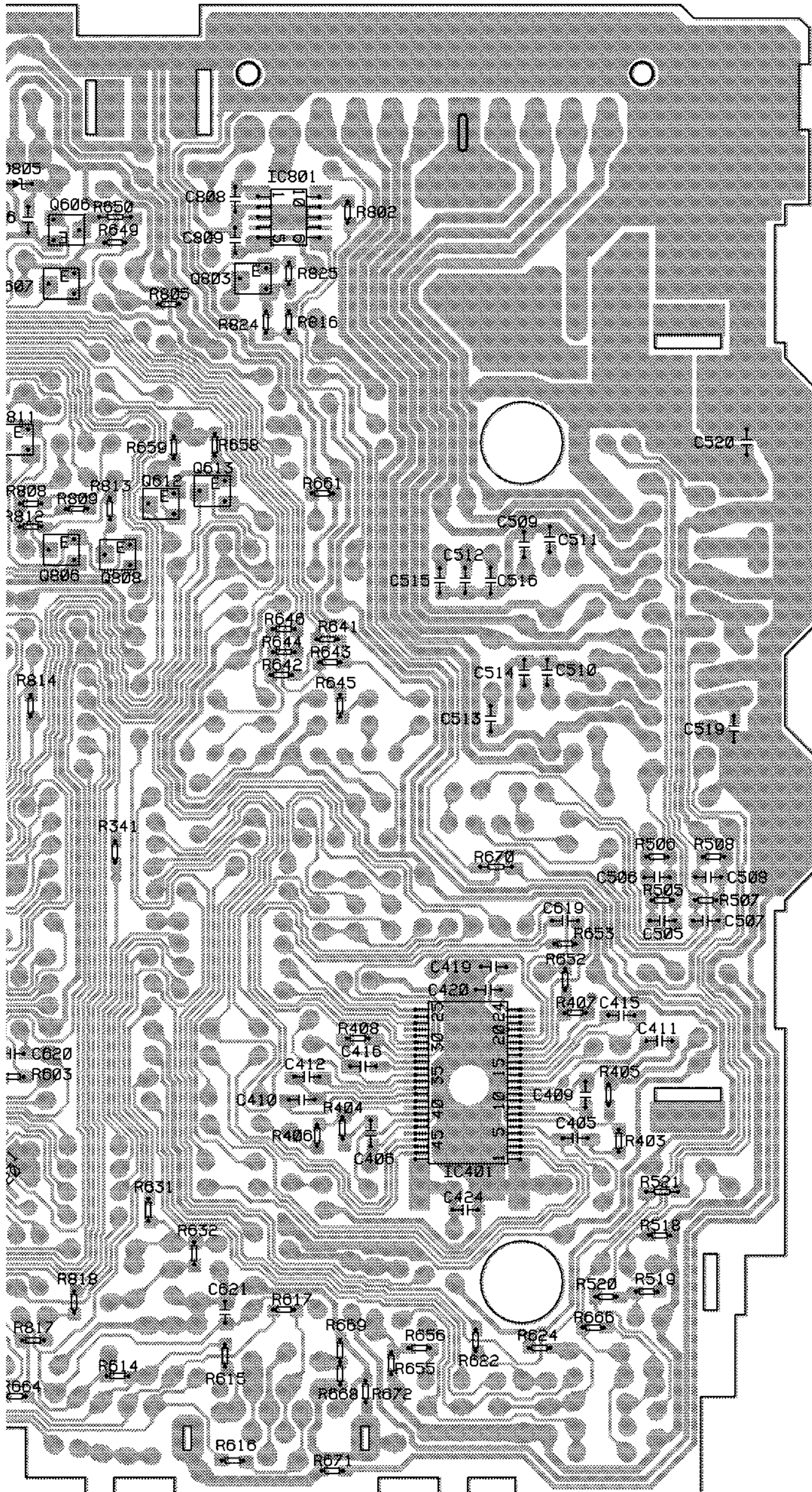

IC, Q

SIDE B

Q402

Q401 Q606
IC801
Q403

Q607 Q803
IC603

Q811
IC301

Q613
Q612

Q806
Q808

Q201

IC201

IC401
IC601

IC701
IC702

A

B

C

D

Fig. 9

A

4.2 FM/AM TUNER UNIT

SIDE A

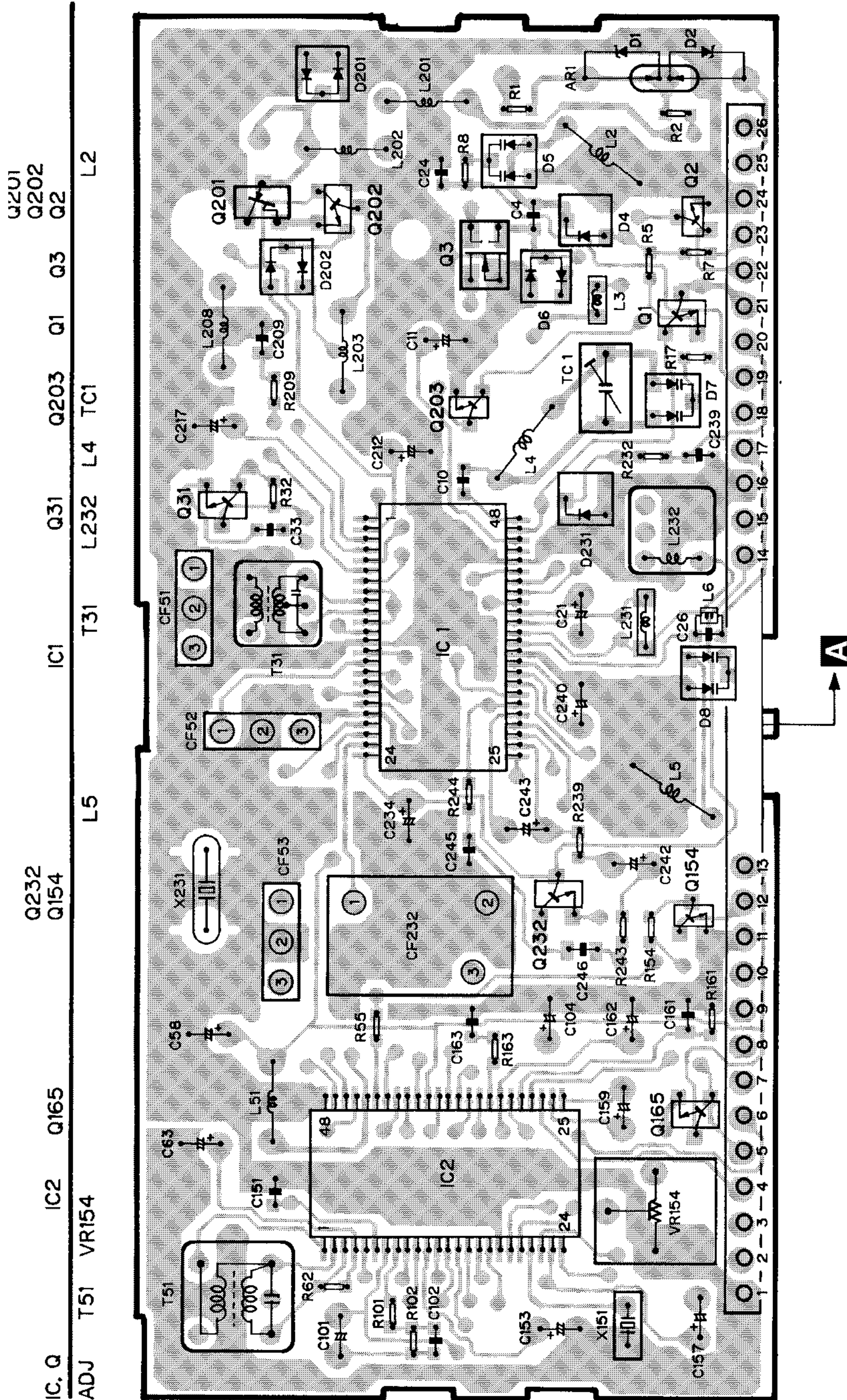

Fig. 10

B FM/AM TUNER UNIT

B

SIDE B

B FM/AM TUNER UNIT

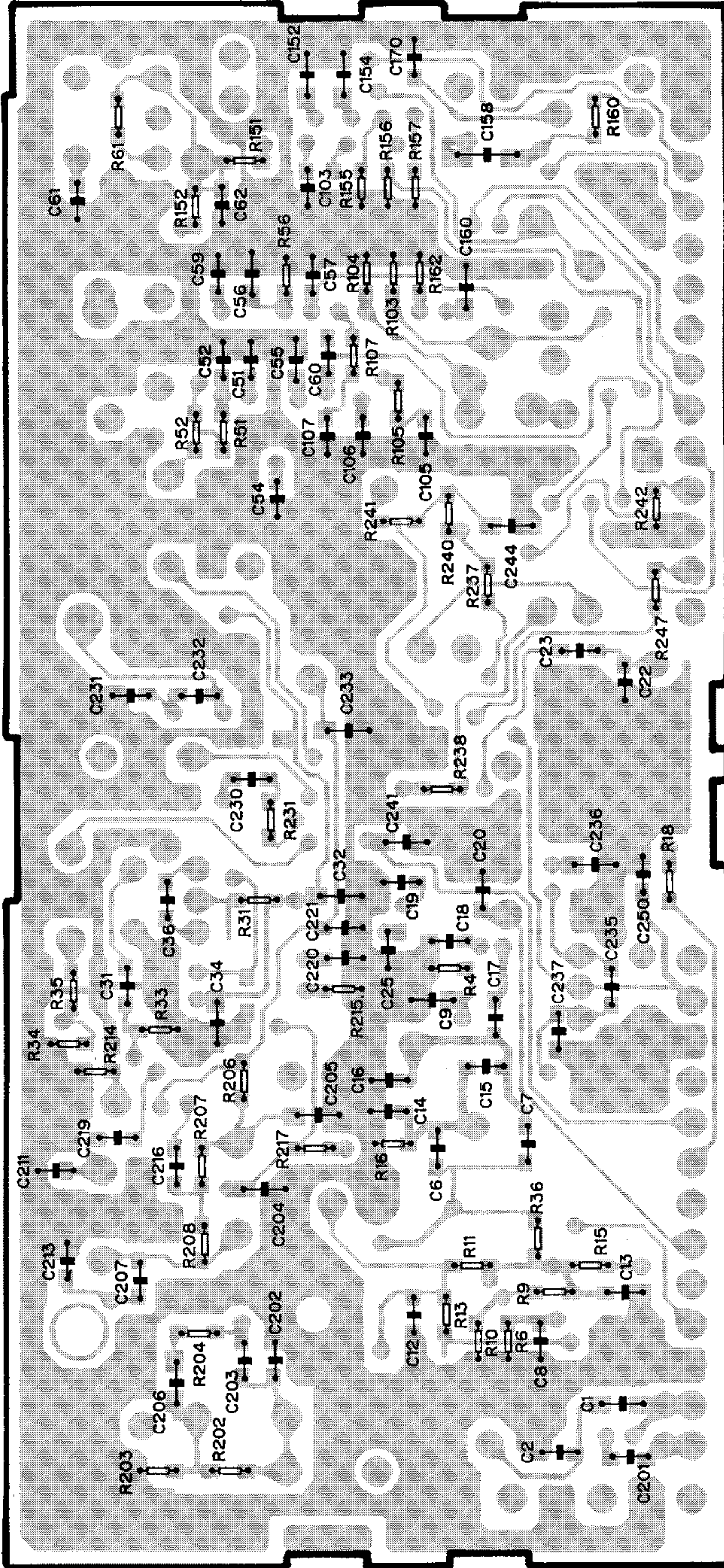

B

A

B

C

D

Fig. 11

B

4.3 KEYBOARD UNIT

SIDE A

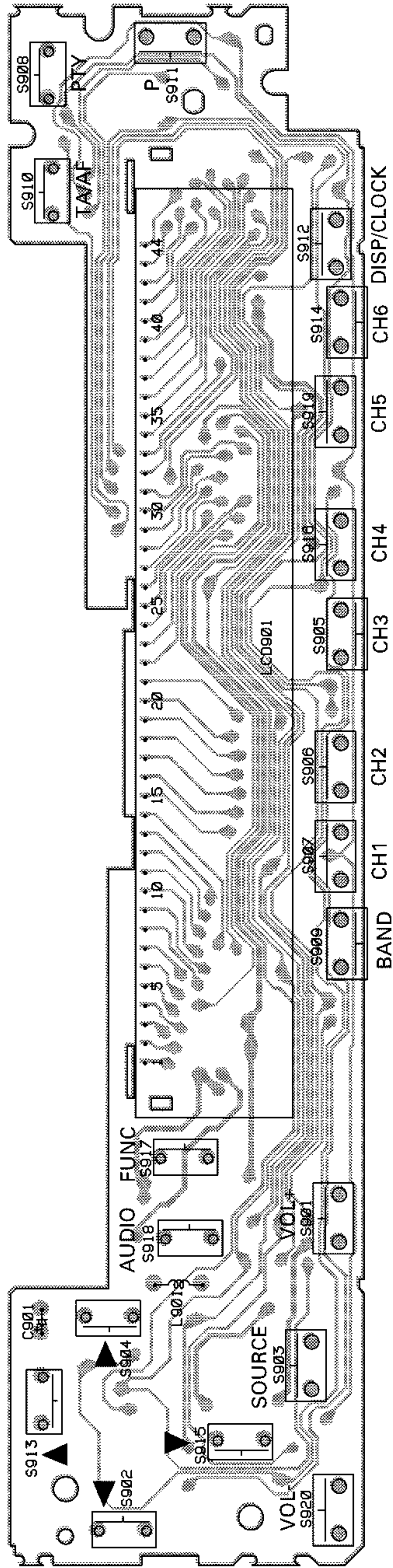

Fig. 12

IC.0

IC901

SIDE B

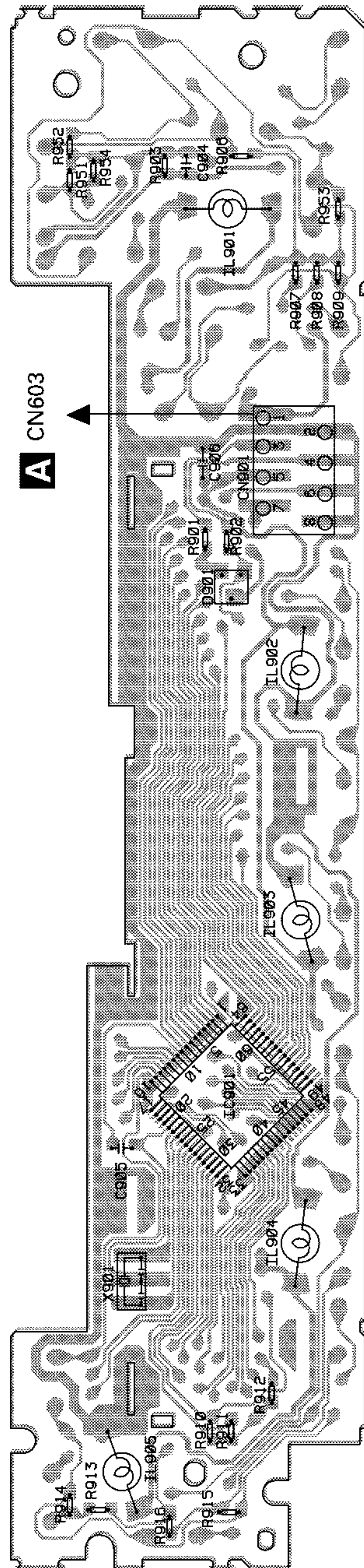

Fig. 13

4.4 CASSETTE PCB

C CASSETTE PCB

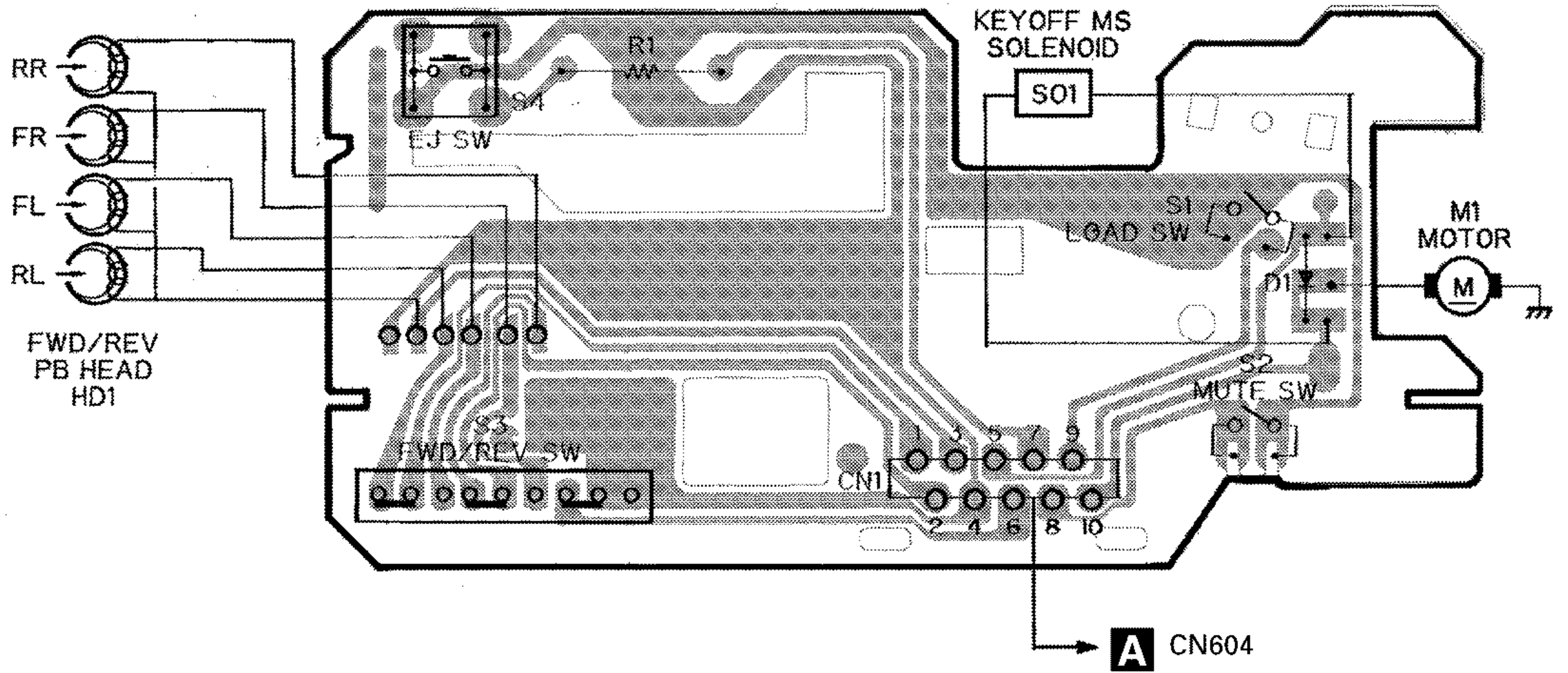

Fig. 14

ELECTRICAL PARTS LIST

NOTE:

- Parts whose parts numbers are omitted are subject to being not supplied.
- The part numbers shown below indicate chip components.

Chip Resistor

RS1/OSOOOJ,RS1/OOSOOOJ

Chip Capacitor (except for CQS.....)

CKS....., CCS....., CSZS.....

====Circuit Symbol and No.====Part Name	Part No.	====Circuit Symbol and No.====Part Name	Part No.
B Unit Number : CWE1466		R 8	RS1/16S332J
Unit Name : FM/AM Tuner Unit		R 9	RS1/16S473J
		R 10	RS1/16S223J
		R 11	RS1/16S124J
		R 13	RS1/16S563J
MISCELLANEOUS			
IC 1 IC	PA4023B		
IC 2 IC	PA4024A	R 15	RS1/16S271J
Q 1 Transistor	2SC2412KLN	R 16	RS1/16S104J
Q 2 Transistor	DTC124EU	R 17	RS1/16S332J
Q 3 FET	3SK263	R 18	RS1/16S332J
		R 31	RS1/16S470J
Q 31 Transistor	2SC2412KLN		
Q 154 Transistor	DTC124EU	R 32	RS1/16S822J
Q 165 Transistor	2SC2412KLN	R 33	RS1/16S822J
Q 201 FET	2SK932	R 34	RS1/16S331J
Q 202 Transistor	2SC2412KLN	R 35	RS1/16S331J
		R 51	RS1/16S271J
Q 203 Transistor	DTC124EU		
D 4 Diode	1SV250	R 52	RS1/16S560J
D 5 Diode	KV1410-F1	R 55	RS1/16S102J
D 6 Diode	MA157	R 56	RS1/16S823J
D 7 Diode	KV1410-F1	R 61	RS1/16S392J
		R 62	RS1/16S393J
D 8 Diode	KV1410-F1		
D 201 Diode	MA157	R 101	RS1/16S272J
D 202 Diode	MA157	R 102	RS1/16S682J
D 231 Diode	SVC253	R 103	RS1/16S333J
L 2 Coil	CTC1133	R 104	RS1/16S334J
		R 105	RS1/16S683J
L 3 Inductor	LCTB2R2K2125		
L 4 Coil	CTC1133	R 107	RS1/16S222J
L 5 Coil	CTC1132	R 151	RS1/16S222J
L 6 Inductor	LCTBR15K1608	R 152	RS1/16S393J
L 51 Ferri-Inductor	LAU150K	R 154	RS1/16S104J
		R 155	RS1/16S273J
L 201 Ferri-Inductor	LAU4R7K		
L 202 Ferri-Inductor	LAU330K	R 156	RS1/16S243J
L 203 Inductor	CTF1287	R 157	RS1/16S203J
L 208 Inductor	LAU121K	R 160	RS1/16S222J
L 231 Inductor	LCTA3R3J3225	R 161	RS1/16S563J
		R 162	RS1/16S105J
T 31 Coil	CTE1116		
T 51 Coil	CTC1136	R 163	RS1/16S222J
TC 1 Capacitor	CCL1038	R 202	RS1/16S223J
CF 51 Ceramic Filter	CTF1292	R 203	RS1/16S225J
CF 52 Ceramic Filter	CTF1292	R 204	RS1/16S103J
		R 206	RS1/16S220J
CF 53 Ceramic Filter	CTF1292		
CF 232 Ceramic Filter	CTF1348	R 207	RS1/16S101J
X 151 Resonator 920.5kHz	CSS1365	R 208	RS1/16S102J
X 231 Crystal Resonator 10.26MHz	CSS1111	R 209	RS1/16S471J
VR 154 Semi-fixed 150kΩ(B)	CCP1213	R 214	RS1/16S822J
		R 215	RS1/16S822J
AR 1 Capacitor with Discharge Gap	DSP-201M		
		R 217	RS1/16S102J
RESISTORS		R 231	RS1/16S272J
		R 232	RS1/16S473J
R 1	RS1/16S0R0J	R 237	RS1/16S103J
R 4	RS1/16S154J	R 238	RS1/16S104J
R 5	RS1/16S391J		
R 6	RS1/16S223J	R 239	RS1/16S104J
R 7	RS1/16S123J	R 240	RS1/16S332J
		R 241	RS1/16S202J
		R 243	RS1/16S123J
		R 244	RS1/16S103J

====Circuit Symbol and No.====Part Name	Part No.	====Circuit Symbol and No.====Part Name	Part No.
R 247	RS1/16S123J	C 212	CEJA470M6R3
CAPACITORS		C 213	CKSRYB103K25
C 1	CCSQCH6R0D50	C 216	CCSRCH101J50
C 2	CCSRCK2R0C50	C 217	CEJA1R5M50
C 4	CCSRCH820J50	C 219	CCSRCH471J50
C 6	CCSRCH820J50	C 220	CKSRYB103K25
C 8	CKSRYB103K25	C 230	CKSRYB103K25
C 9	CKSQYB104K16	C 231	CCSRCH330J50
C 10	CCSRCKR50C50	C 232	CCSRCH150J50
C 11	CEJA1R0M50	C 233	CKSQYB104K16
C 12	CKSRYB222K50	C 234	CEJA330M10
C 13	CKSRYB222K50	C 235	CKSRYB332K50
C 14	CCSRCH220J50	C 236	CKSQYB473K16
C 16	CCSRCH8R0D50	C 237	CCSRCH120J50
C 17	CKSRYB222K50	C 239	CKSRYB472K50
C 18	CKSRYB103K25	C 240	CEJAR47M50
C 19	CKSRYB222K50	C 241	CKSQYB104K16
C 20	CKSRYB222K50	C 242	CEJAR47M50
C 21	CEJA100M16	C 243	CEJAR33M50
C 22	CCSRTH9R0D50	C 244	CKSQYB473K16
C 23	CCSRTH120J50	C 245	CKSRYB123K25
C 24	CCSRCH471J50	C 246	CKSQYB473K16
C 25	CKSRYB103K25	C 250	CCSRCH471J50
C 31	CKSRYB103K25	A Unit Number: CWM5520(KEH-2700R/X1M/EW) Unit Number: CWM5521(KEH-2730R/X1M/EW) Unit Name : Tuner Amp Unit	
C 32	CKSQYB472K50		
C 33	CCSRCH5R0C50		
C 34	CKSQYB104K16		
C 36	CCSRRH201J50	MISCELLANEOUS	
C 51	CKSRYB223K25	IC 201	IC HA12197F
C 52	CKSRYB103K25	IC 301	IC PM2007A
C 54	CCSRCH470J50	IC 401	IC SN761027DL
C 55	CKSQYB223K25	IC 501	IC HA13155
C 56	CKSQYB104K16	IC 601	IC PD4879B
C 57	CKSRYB472K50	IC 602	IC S-80734AN
C 58	CEJA330M10	IC 701	IC PM4006B
C 59	CKSRYB103K25	IC 702	IC NJM2903M
C 61	CCSRCH270J50	IC 801	IC TPD1018F
C 62	CKSRYB103K25	Q 301	Transistor 2SC1740S
C 63	CEJAR15M50	Q 501	Transistor DTC124ES
C 101	CEJANP100M10	Q 502	Transistor DTC124ES
C 102	CKSRYB182K50	Q 601	Transistor DTC143TS
C 103	CKSRYB682K25	Q 602	Transistor DTC124ES
C 104	CEJA2R2M50	Q 603	Transistor 2SC1740S
C 105	CKSRYB103K25	Q 608	Transistor DTA124ES
C 106	CCSRCH151J50	Q 609	Transistor DTC143TS
C 107	CKSRYB103K25	Q 610	Transistor DTC143TS
C 151	CKSRYB472K50	Q 611	Transistor 2SC1740S
C 152	CKSQYB104K16	Q 612	Transistor 2SC2412K
C 153	CEJA3R3M50	Q 613	Transistor 2SC2412K
C 154	CKSQYB104K16	Q 701	Transistor DTC143TS
C 157	CEJA3R3M50	Q 702	Transistor 2SC1740S
C 158	CKSYB474K16	Q 703	Transistor 2SD1468S
C 159	CEJA220M6R3	Q 704	Transistor 2SD1468S
C 160	CKSQYB104K16	Q 801	Transistor 2SD2037
C 161	CKSQYB104K16	Q 802	Transistor 2SB1243
C 162	CEJA3R3M50	Q 803	Transistor 2SC2412K
C 163	CKSRYB102K50	Q 804	Transistor 2SD2396
C 170	CCSRCH100D50	Q 805	Transistor 2SA1048
C 201	CCSRCH471J50	Q 806	Transistor 2SC2412K
C 202	CCSRCH100D50	Q 807	Transistor 2SA1674
C 203	CKSRYB332K50	Q 808	Transistor 2SC2412K
C 204	CKSQYB473K16	Q 809	Transistor 2SA933S
C 205	CKSQYB473K16	Q 810	Transistor 2SB1242
C 206	CKSQYB104K16	Q 811	Transistor DTC143TK
C 207	CCSRCH560J50	D 201	Diode 1SS270
C 209	CKSQYB104K16	D 302	Diode 1SS270
C 211	CCSRCH101J50	D 501	Compound Parts CWW1352
		D 601	Diode 1SS270

KEH-2700R,2730R

====Circuit Symbol and No.====Part Name	Part No.	====Circuit Symbol and No.====Part Name	Part No.
D 602 Diode	HZS7L(A1)	R 318	RS1/10S0R0J
D 603 Diode	1SS270	R 319	RS1/10S472J
D 604 Diode	1SS270	R 320	RS1/10S682J
D 605 Diode	1SS270	R 321	RS1/10S222J
D 606 Diode	1SS270	R 322	RS1/10S472J
D 607 Diode	1SS270	R 323	RS1/10S682J
D 608 Diode	1SS270	R 324	RD1/4PU102J
D 609 Diode	1SS270	R 326	RD1/4PU0R0J
D 610 Diode	1SS270	R 328	RS1/10S561J
D 611 Diode	1SS270	R 332	RS1/10S103J
D 612 Diode	HZS9L(A2)	R 333	RS1/8S393J
D 613 Diode	HZS7L(C3)	R 334	RD1/4PU562J
D 614 Diode	HZS7L(A1)	R 335	RD1/4PU472J
D 615 Diode	1SS270	R 336	RD1/4PU473J
D 616 Diode	1SS270	R 337	RS1/10S473J
D 701 Diode	1SS270	R 338	RD1/4PU104J
D 801 Diode	1SR139-400	R 339	RS1/10S473J
D 802 Diode	1SR139-400	R 340	RS1/10S473J
D 803 Diode	1SR139-400	R 341	RS1/10S681J
D 804 Diode	MA8056(H)	R 342	RS1/10S681J
D 805 Diode	MA8091(M)	R 343	RD1/4PU681J
D 806 Diode	1SR139-400	R 344	RD1/4PU681J
D 807 Diode	1SR139-400	R 345	RD1/4PU222J
L 301 Ferri-Inductor	LAU101K	R 346	RS1/8S472J
L 302 Ferri-Inductor	LAU101K	R 349	RD1/4PU102J
L 601 Ferri-Inductor	LAU101K	R 350	RS1/10S510J
L 602 Ferri-Inductor	LAU101K	R 352	RS1/10S0R0J
L 603 Ferri-Inductor	LAU101K	R 353	RS1/10S0R0J
L 701 Ferri-Inductor	LAU101K	R 354	RD1/4PU102J
L 951 Choke Coil 600H	CTH1168	R 355	RS1/8S0R0J
X 301 Crystal Resonator 7.200MHz	CSS1379	R 403	RS1/10S272J
X 601 Ceramic Resonator 4.194MHz	CSS1047	R 404	RS1/10S272J
X 701 Crystal Resonator 4.332MHz	CSS1056	R 405	RS1/10S151J
VR 701 Semi-fixed 22kΩ(B)	CCP1321	R 406	RS1/10S151J
FU 951 Fuse 10A	CEK1136	R 407	RS1/10S221J
FM/AM Tuner Unit	CWE1466	R 408	RS1/10S221J
RESISTORS		R 501	RD1/4PU202J
R 201	RS1/10S473J	R 502	RD1/4PU202J
R 202	RS1/10S473J	R 503	RD1/4PU202J
R 203	RS1/10S181J	R 504	RD1/4PU202J
R 204	RS1/10S181J	R 505	RS1/10S222J
R 205	RS1/10S274J	R 506	RS1/10S222J
R 206	RS1/10S274J	R 507	RS1/10S222J
R 207	RS1/10S133J	R 508	RS1/10S222J
R 208	RS1/10S133J	R 509	RD1/4PU2R2J
R 209	RS1/10S183J	R 510	RD1/4PU2R2J
R 210	RS1/10S183J	R 511	RD1/4PU2R2J
R 211	RS1/10S472J	R 512	RD1/4PU2R2J
R 212	RS1/10S472J	R 513	RD1/4PU2R2J
R 213	RS1/10S512J	R 514	RD1/4PU2R2J
R 214	RS1/10S512J	R 515	RD1/4PU2R2J
R 219	RD1/4PU273J	R 516	RD1/4PU2R2J
R 220	RD1/4PU273J	R 517	RD1/4PU103J
R 301	RS1/10S272J	R 518	RS1/10S153J
R 302	RS1/10S272J	R 519	RS1/10S221J
R 305	RS1/10S0R0J	R 520	RS1/10S101J
R 306	RD1/4PU222J	R 521	RS1/8S103J
R 307	RS1/8S222J	R 601	RS1/10S104J
R 308	RS1/8S222J	R 602	RS1/8S104J
R 309	RS1/10S102J	R 604	RS1/10S473J
R 310	RS1/10S0R0J	R 610	RD1/4PU473J
R 311	RS1/8S272J	R 612	RS1/8S473J
R 312	RD1/4PU222J	R 613	RS1/10S473J
R 314	RS1/8S392J	R 614	RS1/10S473J
R 315	RS1/10S392J	R 615	RS1/10S222J
R 316	RS1/10S152J		
R 317	RS1/10S103J		

====Circuit Symbol and No.====Part Name	Part No.	====Circuit Symbol and No.====Part Name	Part No.
R 616	RS1/10S222J	R 812	RS1/10S103J
R 617	RS1/10S222J	R 813	RS1/10S102J
R 618	RD1/4PU103J	R 814	RS1/10S473J
R 619	RS1/8S473J	R 816	RS1/10S472J
R 620	RS1/10S473J	R 817	RS1/10S223J
R 621	RD1/4PU104J	R 818	RS1/10S222J
R 622	RS1/10S473J	R 819	RS1/10S472J
R 623	RD1/4PU473J	R 820	RD1/4PU102J
R 624	RS1/10S332J	R 821	RD1/4PU1R5J
R 625	RS1/10S102J	R 822	RD1/4PU1R5J
R 629	RS1/10S103J	R 823	RD1/4PU1R0J
R 630	RD1/4PU152J	R 824	RS1/10S103J
R 631	RS1/10S102J	R 825	RS1/10S103J
R 632	RS1/10S124J		
R 652	RS1/10S104J		
R 653	RS1/10S104J		
R 655	RS1/10S223J		
R 656	RS1/10S103J		
R 657	RD1/4PU472J		
R 658	RS1/10S473J		
R 659	RS1/10S223J		
R 660	RD1/4PU473J		
R 661	RS1/10S473J		
R 662	RD1/4PU223J		
R 663	RD1/4PU473J		
R 664	RS1/10S222J		
R 668	RS1/10S0R0J		
R 673	RS1/10S0R0J		
R 701	RD1/4PU102J		
R 702	RD1/4PU102J		
R 703	RS1/8S102J		
R 704	RD1/4PU102J		
R 705	RS1/10S102J		
R 706	RS1/10S0R0J		
R 707	RS1/10S333J		
R 708	RS1/10S102J		
R 709	RS1/10S562J		
R 710	RS1/10S222J		
R 711	RS1/10S222J		
R 712	RS1/10S562J		
R 713	RS1/10S684J		
R 714	RS1/8S103J		
R 715	RS1/10S224J		
R 716	RS1/10S224J		
R 717	RS1/10S222J		
R 718	RS1/10S222J		
R 719	RS1/10S223J		
R 720	RS1/10S223J		
R 721	RS1/10S105J		
R 722	RS1/10S224J		
R 723	RS1/10S562J		
R 724	RS1/10S681J		
R 725	RD1/4PU681J		
R 726	RS1/10S681J		
R 727	RS1/10S102J		
R 801	RD1/4PU102J		
R 802	RS1/10S472J		
R 803	RS1/10S101J		
R 804	RD1/4PU332J		
R 805	RS1/10S103J		
R 806	RD1/4PU102J		
R 807	RD1/4PU122J		
R 808	RS1/10S103J		
R 809	RS1/10S102J		
R 810	RD1/4PU473J		
R 812			
R 813			
R 814			
R 816			
R 817			
R 818			
R 819			
R 820			
R 821			
R 822			
R 823			
R 824			
R 825			
CAPACITORS			
R 201	CKSQYB561K50		
R 202	CKSQYB561K50		
R 205	CKSQYB103K25		
R 206	CKSQYB103K25		
R 207	CEALR47M50		
R 208	CEALR47M50		
R 209	CEJA1R0M50		
R 210	CEJA1R0M50		
R 213	CEAL220M16		
R 219	CKSQYB104K16		
R 220	CEAL100M16		
R 223	CKSQYB105K10		
R 224	CKSQYB105K10		
R 225	CEAL470M6R3		
R 226	CEAL470M6R3		
R 301	CKSQYB223K25		
R 302	CKSQYB223K25		
R 303	CKSQYB223K25		
R 307	CKSQYB103K25		
R 308	CCSQCH101K50		
R 311	CCSQCH101K50		
R 313	CKSQYB223K25		
R 314	CKSQYB103K25		
R 315	CEAL220M6R3		
R 316	CKSQYB103K25		
R 317	CKSQYB103K25		
R 318	CKSQYB102K50		
R 319	CEAL220M16		
R 320	CCSQCH150J50		
R 321	CCSQCH150J50		
R 322	CKSQYB103K25		
R 324	CEALR47M50		
R 325	CCH1250		
R 326	CKSQYB103K25		
R 328	CKLSR473K16		
R 331	CKSQYB104K16		
R 332	CEAL220M6R3		
R 333	CKSQYB103K25		
R 334	CEAL220M6R3		
R 335	CKSQYB103K25		
R 336	CKSQYB223K25		
R 337	CKSQYB103K25		
R 340	CCH1165		
R 341	CKSQYB103K25		
R 342	CKSQYB473K16		
R 343	CKSQYB102K50		
R 401	CEJA2R2M50		
R 402	CEJA2R2M50		
R 403	CEJA100M16		
R 404	CEJA100M16		

KEH-2700R,2730R

====Circuit Symbol and No.====Part Name	Part No.
C 405	CKSQYB822K50
C 406	CKSQYB822K50
C 407	CEJA1R0M50
C 408	CEJA1R0M50
C 409	CKSQYB183K25
C 410	CKSQYB183K25
C 411	CKSQYB102K50
C 412	CKSQYB102K50
C 413	CEJA2R2M50
C 414	CEJA2R2M50
C 415	CKSQYB333K25
C 416	CKSQYB333K25
C 417	CEJA220M6R3
C 418	CEJA2R2M50
C 419	CKSQYB104K16
C 420	CKSQYB103K25
C 423	CEJA470M10
C 424	CKSQYB104K16
C 425	CKSYB105K16
C 426	CKSYB105K16
C 501	CEJA4R7M35
C 502	CEJA4R7M35
C 503	CEJA4R7M35
C 504	CEJA4R7M35
C 505	CKSQYB102K50
C 506	CKSQYB102K50
C 507	CKSQYB102K50
C 508	CKSQYB102K50
C 509	CKSQYB104K16
C 510	CKSQYB104K16
C 511	CKSQYB104K16
C 512	CKSQYB104K16
C 513	CKSQYB104K16
C 514	CKSQYB104K16
C 515	CKSQYB104K16
C 516	CKSQYB104K16
C 517	CEJA330M10
C 518	CEJA100M16
C 519	CKSQYB104K16
C 520	CKSQYB104K16
C 601	CCSQCH101K50
C 602	CEAL4R7M35
C 604	CCSQCH101K50
C 606	CKSQYB104K16
C 607	CKSQYB224K16
C 608	CEJA2R2M50
C 619	CKSQYB102K50
C 620	CCSQCH101K50
C 621	CCSQCH101J50
C 623	CKSQYB102K50
C 701	CEAL4R7M35
C 702	CKSQYB104K16
C 703	CCSQCH220J50
C 704	CCSQCH220J50
C 705	CKSQYB472K50
C 706	CKSQYB104K16
C 707	CKSYB105K16
C 708	CKSQYB104K16
C 709	CKSQYB222K50
C 710	CKSQYB104K16
C 711	CKSQYB104K16
C 712	CKSQYB223K25
C 713	CEAL4R7M35
C 714	CKSQYB103K25
C 715	CKSQYB103K25
C 716	CKSQYB223K25
C 717	CKSQYB471K50
C 801	3300μF/16V CCH1018
C 802	470μF/16V CCH1183
C 803	CKSQYB102K50

====Circuit Symbol and No.====Part Name	Part No.
C 804	CKSQYB473K16
C 805	CEJA101M10
C 806	CKSQYB103K25
C 807	330μF/10V CCH1181
C 808	CKSQYB103K25
C 809	CKSQYB104K16
C 811	100μF/16V CCH1179

D Unit Number: CWM5529(KEH-2700R/X1M/EW)
Unit Name : Keyboard Unit

MISCELLANEOUS

IC 901	IC	PD6196A
D 901	Diode	STZ6R2N
L 901	Ferri-Inductor	LAU101K
X 901	Ceramic Resonator 4.970MHz	CSS1422
S 901	Push Switch	CSG1093
S 902	Switch	CSG1081
S 903	Push Switch	CSG1093
S 904	Switch	CSG1081
S 905	Push Switch	CSG1093
S 906	Push Switch	CSG1093
S 907	Push Switch	CSG1093
S 908	Switch	CSG1081
S 909	Push Switch	CSG1093
S 910	Switch	CSG1081
S 911	Push Switch	CSG1093
S 912	Push Switch	CSG1093
S 913	Switch	CSG1081
S 914	Push Switch	CSG1093
S 915	Switch	CSG1081
S 916	Push Switch	CSG1093
S 917	Switch	CSG1081
S 918	Switch	CSG1081
S 919	Push Switch	CSG1093
S 920	Push Switch	CSG1093
IL 901	Lamp 14V 40mA	CEL1547
IL 902	Lamp 14V 40mA	CEL1549
IL 903	Lamp 14V 40mA	CEL1549
IL 904	Lamp 14V 40mA	CEL1549
IL 905	Lamp 14V 40mA	CEL1547
LCD 901	LCD	CAW1391

RESISTORS

R 901	RS1/10S222J
R 902	RS1/10S222J
R 903	RS1/10S472J
R 906	RS1/10S473J
R 907	RS1/10S473J
R 908	RS1/10S473J
R 909	RS1/10S473J
R 910	RS1/10S473J
R 911	RS1/10S473J
R 912	RS1/10S473J
R 914	RS1/10S0R0J
R 916	RS1/10S0R0J

CAPACITORS

C 901	CEAL100M16
C 904	CKSQYB104K50
C 905	CKSQYB102K50
C 906	CCSCH101J50

====Circuit Symbol and No.====Part Name Part No.

D Unit Number: CWM5530(KEH-2730R/X1M/EW)
 Unit Name : Keyboard Unit

MISCELLANEOUS

IC	901	IC	PD6196A
D	901	Diode	STZ6R2N
L	901	Ferri-Inductor	LAU101K
X	901	Ceramic Resonator 4.970MHz	CSS1422
S	901	Push Switch	CSG1093
S	902	Switch	CSG1081
S	903	Push Switch	CSG1093
S	904	Switch	CSG1081
S	905	Push Switch	CSG1093
S	906	Push Switch	CSG1093
S	907	Push Switch	CSG1093
S	908	Switch	CSG1081
S	909	Push Switch	CSG1093
S	910	Switch	CSG1081
S	911	Push Switch	CSG1093
S	912	Push Switch	CSG1093
S	913	Switch	CSG1081
S	914	Push Switch	CSG1093
S	915	Switch	CSG1081
S	916	Push Switch	CSG1093
S	917	Switch	CSG1081
S	918	Switch	CSG1081
S	919	Push Switch	CSG1093
S	920	Push Switch	CSG1093
IL	901	Lamp 14V 40mA	CEL1479
IL	902	Lamp 14V 40mA	CEL1508
IL	903	Lamp 14V 40mA	CEL1508
IL	904	Lamp 14V 40mA	CEL1508
IL	905	Lamp 14V 40mA	CEL1479
LCD	901	LCD	CAW1391

RESISTORS

R	901	RS1/10S222J
R	902	RS1/10S222J
R	903	RS1/10S472J
R	906	RS1/10S473J
R	907	RS1/10S473J
R	908	RS1/10S473J
R	909	RS1/10S473J
R	910	RS1/10S473J
R	911	RS1/10S473J
R	912	RS1/10S473J
R	914	RS1/10S0R0J
R	916	RS1/10S0R0J

CAPACITORS

C	901	CEAL100M16
C	904	CKSQYB104K50
C	905	CKSQYB102K50
C	906	CCSCH101J50

====Circuit Symbol and No.====Part Name Part No.

C Unit Number:
 Unit Name : Cassette PCB

S	1	Switch(Load)	ESN1016
S	2	Switch(Mute)	ESN1017
S	3	Switch(FWD/REV)	ESH1006
S	4	Switch(Eject)	ESG1006
R	1		RD1/4HM472J

Miscellaneous Parts List

M	1	Motor Unit	EXA1467
HD	1	Head Assy	EXA1466

6. ADJUSTMENT

● Connection Diagram

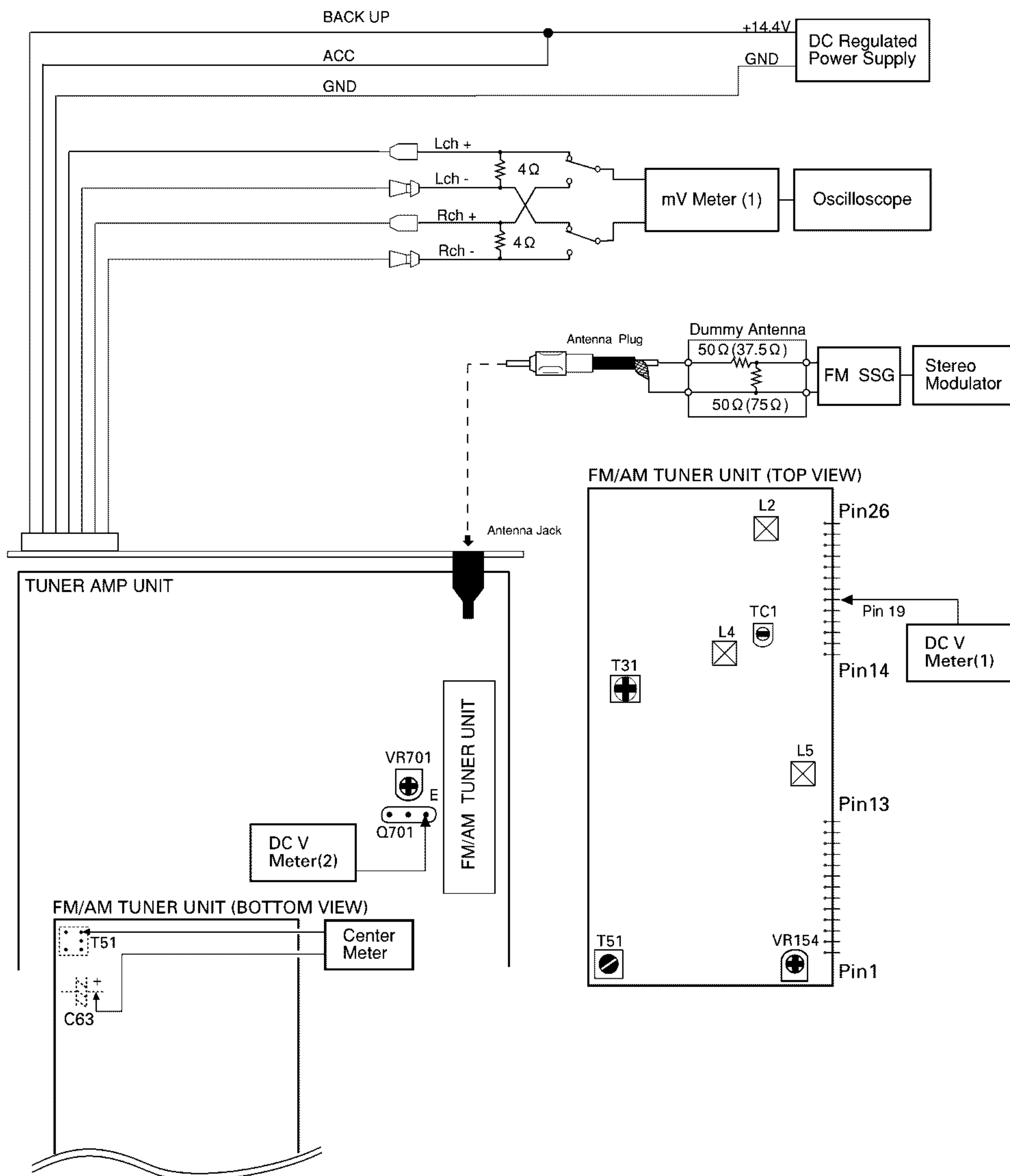

Fig. 15

FM ADJUSTMENT

Modulation M:MONO MOD., 400Hz 30%(22.5kHz Dev.) or 400Hz 100%(75kHz Dev.)

S:STEREO MOD., 1kHz, L or R=30%(20.25kHz+7.5kHz Dev.)

S2:STEREO MOD., 400Hz, L or R=60%(40.50kHz+7.5kHz Dev.)

NOTE:Before proceeding to further adjustments after switching power ON, let the tuner run for ten minutes to allow the circuits to stabilize.

	No.	FM SSG		Displayed Frequency(MHz)	Adjustment Point	Adjustment Method (Switch Position)
		Frequency(MHz)	Level(dBf)			
TUN Volt	1	*****	*****	108.0	L5	DC V Meter(1) : 6V
IF	2	98.1 M	60	98.1	T51	Center Meter : 0
ANT Coil	3	98.1 M	5	98.1	L2	mV Meter(1) : Maximum
RF Coil	4	98.1 M	5	98.1	L4	mV Meter(1) : Maximum
Image	5	129.3 M	60—80	107.9	TC1	mV Meter(1) : Minimum
IFT	6	98.1 M	5	98.1	T31	mV Meter(1) : Maximum (STEREO MODE)
ARC	7	98.1 S	40	98.1	VR154	mV Meter(1) : Separation 5dB (STEREO MODE)

RDS SL ADJUSTMENT

	No.	FM SSG		Displayed Frequency(MHz)	Adjustment Point	Adjustment Method (Switch Position)
		Frequency(MHz)	Level(dBf)			
	1	104.0 S2	35	104.0	VR701	DC V Meter(2) : 1.75V+0.05V,-0.35V

7. GENERAL INFORMATION

7.1 PARTS

7.1.1 IC

PA4023B

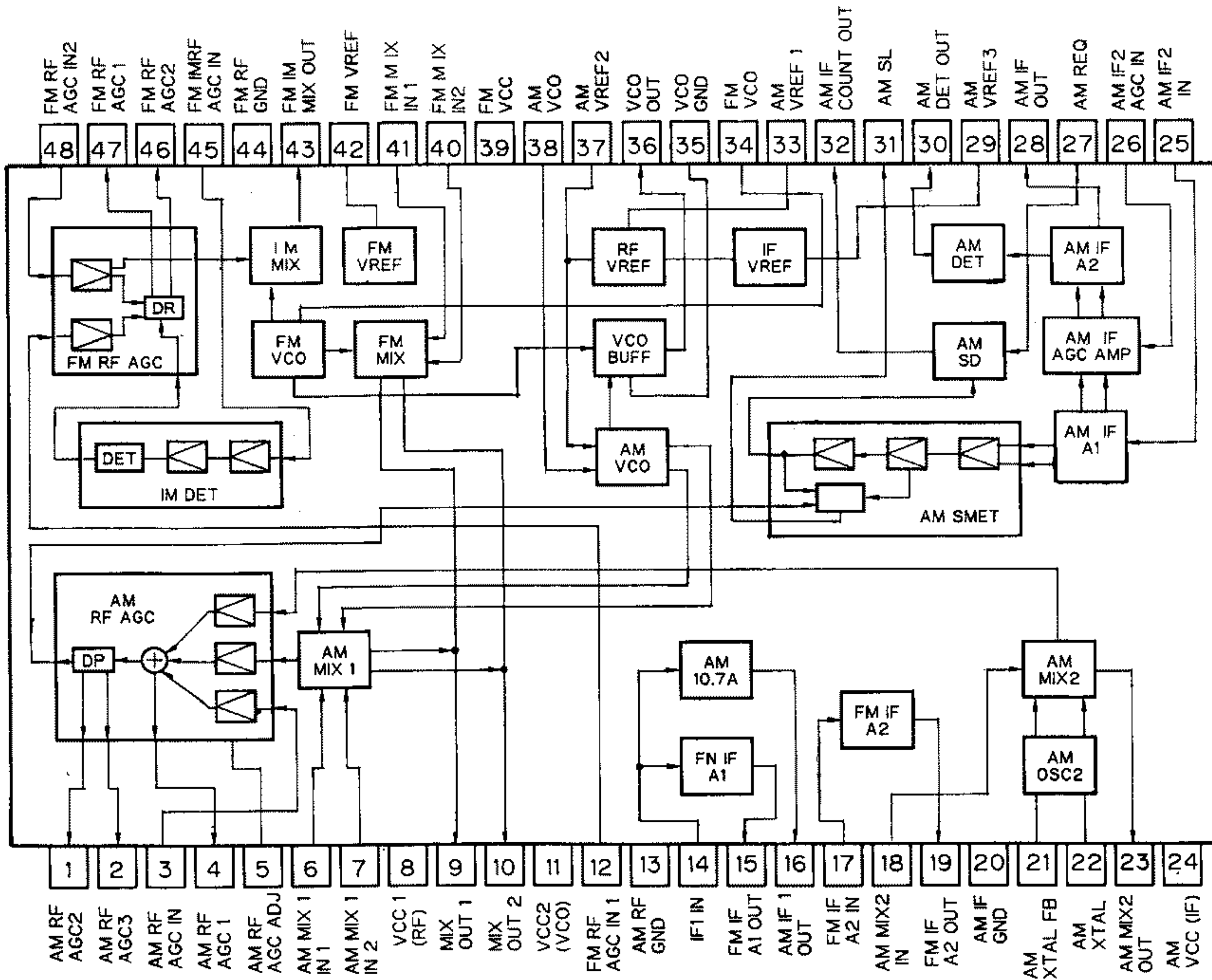

HA12197F

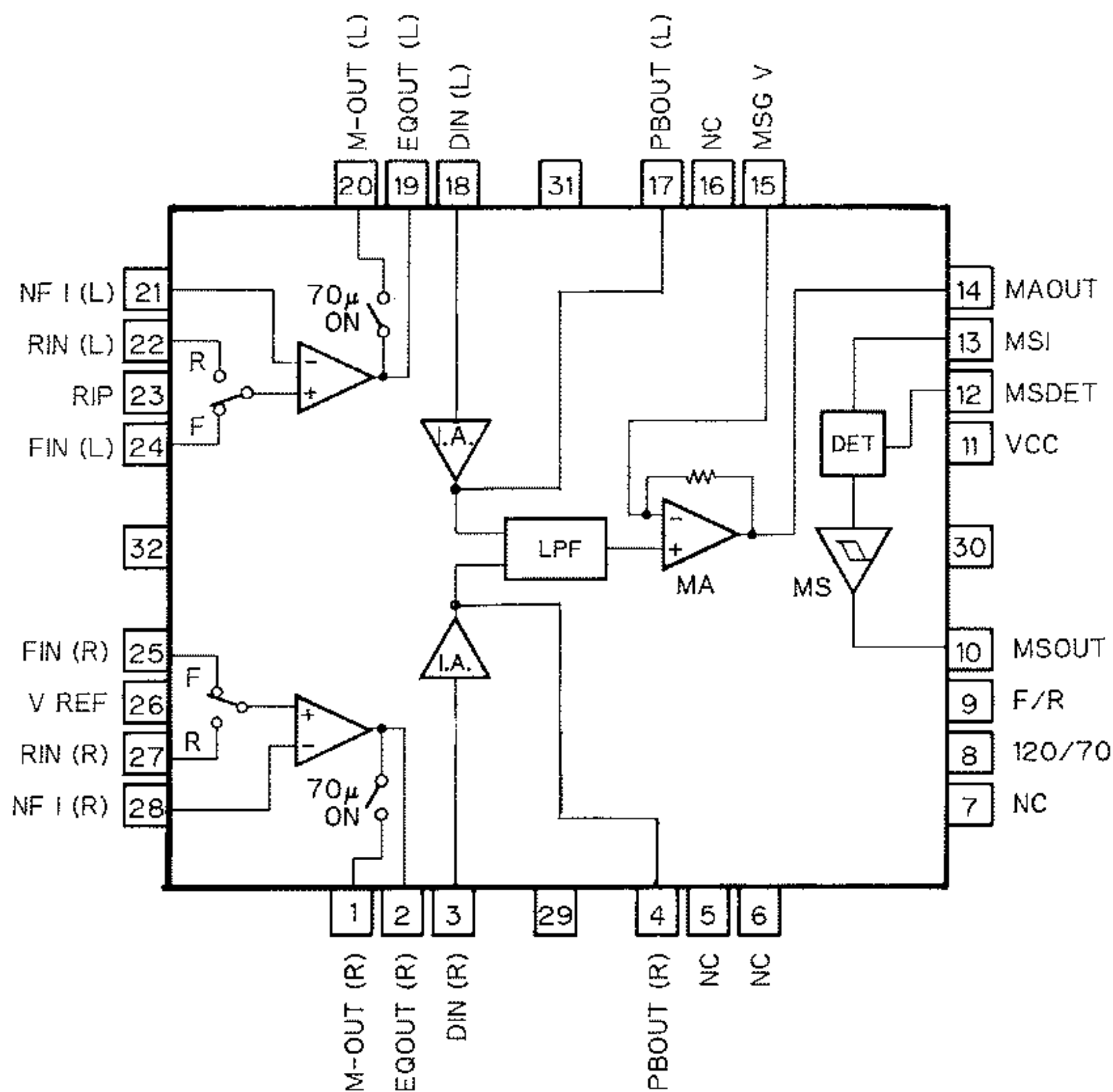

PM2007A

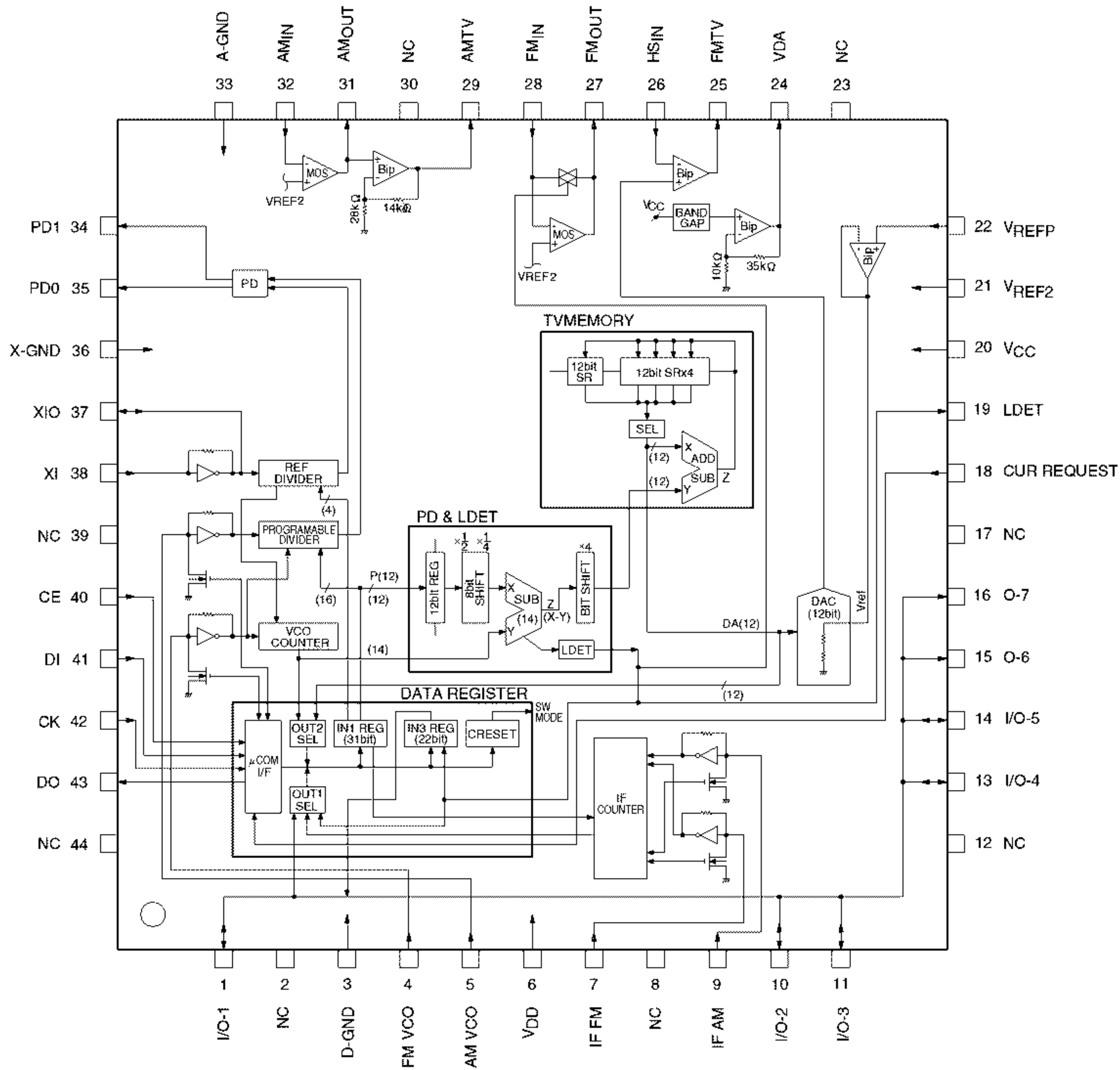

SN761027DL

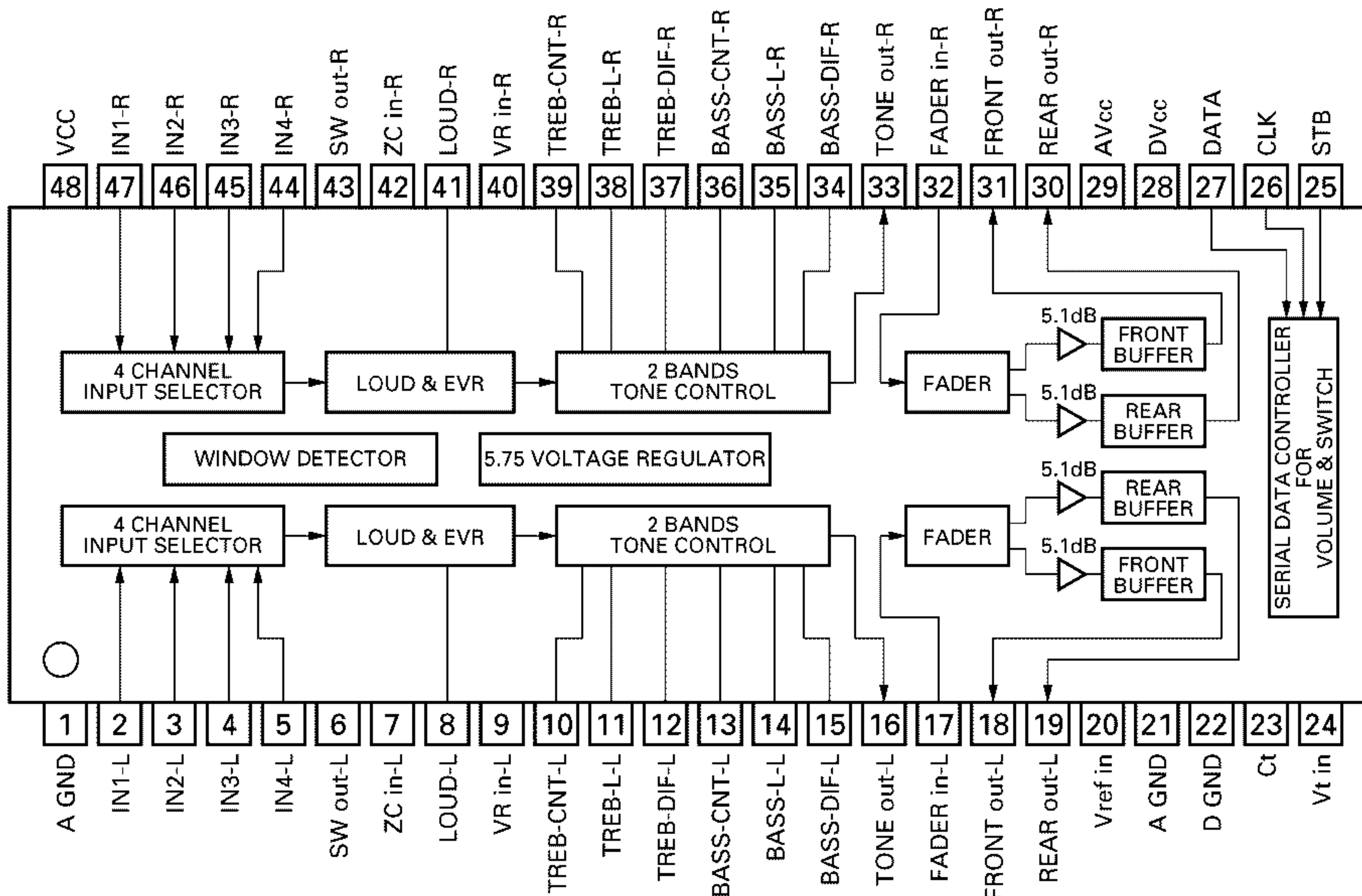

KEH-2700R,2730R

HA13155

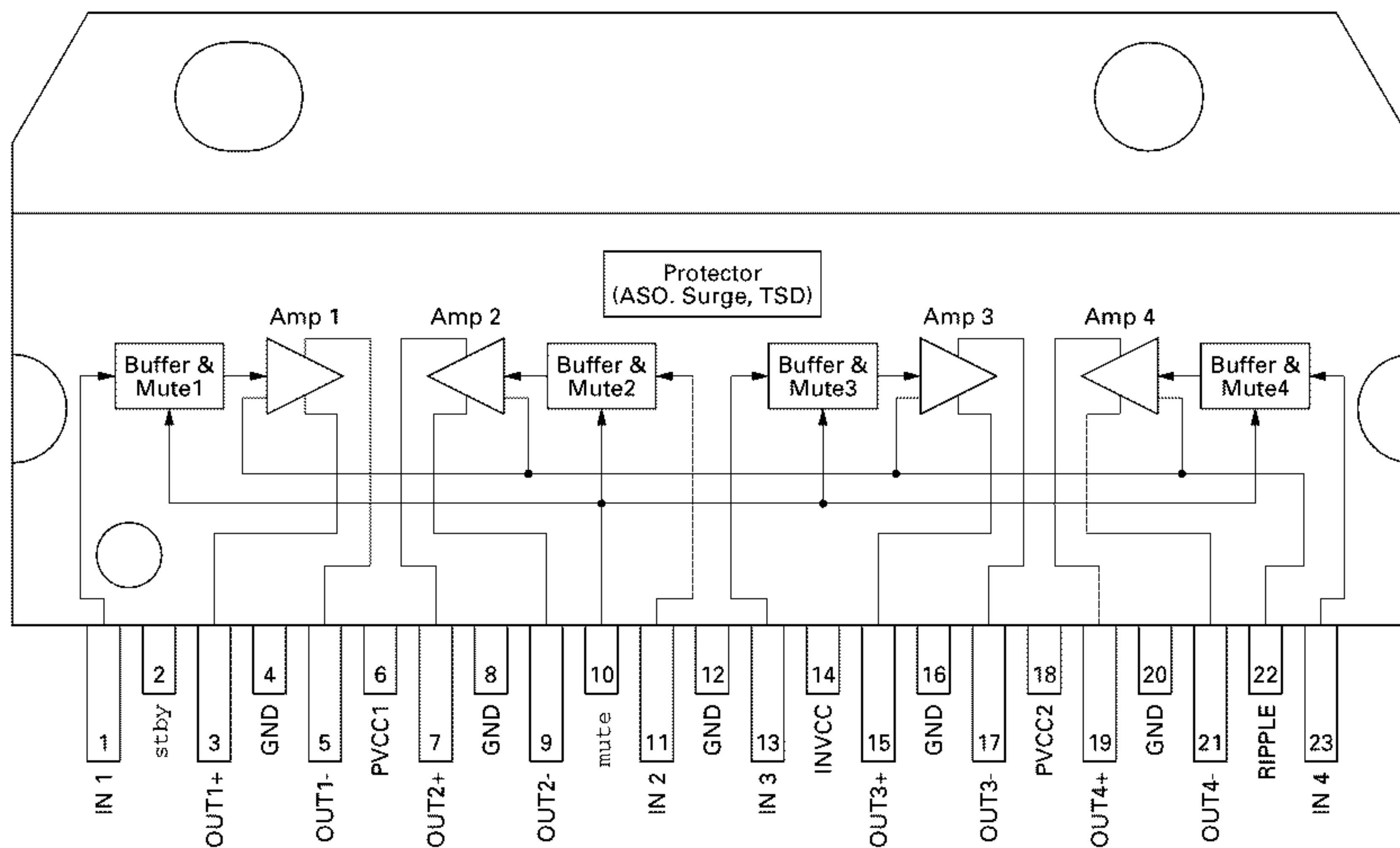

PM4006B

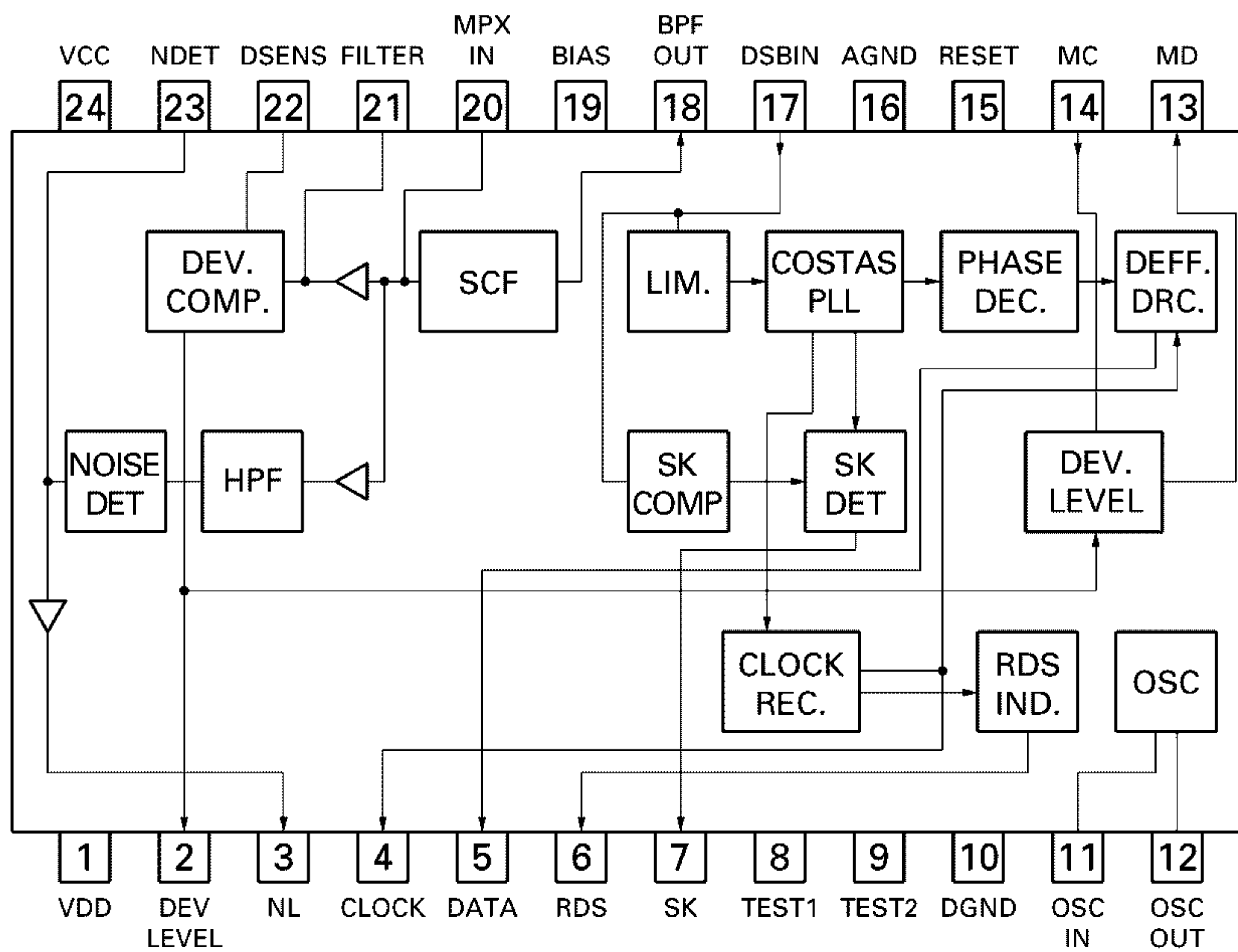

● Pin Functions (PD4879B)

Pin No.	Pin Name	I/O	Format	Function and Operation
1	RDT	I		FROM data input
2	NC			Not used
3	ADPW			A/D converter power
4	GND			GND
5	$\overline{\text{DRST}}$	O	C	Decoder reset output
6	MDSSENS	I		Modulation detect input
7	AVREF1			(D/A converter standard voltage)
8	KYDT	I		Key data input
9	DPDT	O	C	Display data output
10	$\overline{\text{DSSENS}}$	I		Grille detach sense
11	TUNPDI	I		PLL IC data input
12	TUNPDO	O	C	PLL IC data output
13	TUNPCK	O	C	PLL IC clock output
14	TUNPCE	O	C	PLL IC chip enable output
15	$\overline{\text{CURRO}}$	O	C	Tuner voltage FIX output
16	NC			Not used
17	SK	I		SK signal input
18	MUTCNT	I		NF mute control input
19-21	NC			Not used
22	$\overline{\text{SWVDD}}$	O	C	Grille power supply control output
23	NC			Not used
24	VDT	O	C	Data output for electronic volume
25	VCK	O	C	Clock output for electronic volume
26	VST	O	C	Strobe pulse output for electronic volume
27	SYSPW	O	C	System power supply control output
28	$\overline{\text{MUTE}}$	O	C	Mute output
29	DMINH	O	C	Mechanism mute cancel output
30,31	NC			Not used
32	$\overline{\text{EW/BEW}}$	I	C	Model select
33	GND			GND
34-36	NC			Not used
37	$\overline{\text{TMUTE}}$	O	N	Tuner mute output
38	FM	O	N	FM power control output
39	AM	O	N	AM power control output
40	NC			Not used
41-44	NC			Not used
45	PEE	O	C	Beep tone output
46	NC			Not used
47	RDS57K	I		57kHzBP-OUT sense input
48	NC			Not used
49	NC			Not used
50	$\overline{\text{EJECT}}$	I		Eject key input pin
51	$\overline{\text{TAPLD}}$	I		Tape loading input
52	MECPW	O	C	Cassette mechanism power output
53	$\overline{\text{MCMUT}}$	I		Mechanism mute request
54	$\overline{\text{NOR/REV}}$	I		Normal reverse input
55	MSIN	I		Cassette mechanism MS sense input
56	NC			Not used
57	NC			Not used
58	MTL	O	C	METAL output
59	NR	O	C	NR output
60	$\overline{\text{RESET}}$	I		Reset input
61	$\overline{\text{LDET}}$	I		PLL lock sense input
62	$\overline{\text{RCK}}$	I		RDS demodulation clock input
63	CLKIN	I		Clock input
64	$\overline{\text{ASENS}}$	I		ACC power sense input
65	$\overline{\text{BSENS}}$	I		Back up power sense input
66	SD	I		SD input
67	$\overline{\text{ST}}$	I		Stereo input
68	VDD			Power supply

KEH-2700R,2730R

Pin No.	Pin Name	I/O	Format	Function and Operation
69	X2			Oscillator output
70	X1			Oscillator input
71	GND			GND
72	NC			Not used
73	TESTIN	I		Test program mode input
74	AVDD			Positive power supply terminal for analog circuit
75	AVREF0			(A/D converter standard voltage input)
76	SL	I		Signal level input from tuner
77	CL	I		Synchronizing signal input of display data latch
78	NL	I		Noise level input
79-79	TL	I		Trigger level input
80	RDSLK	I		RDS LK signal input

*PD4879B

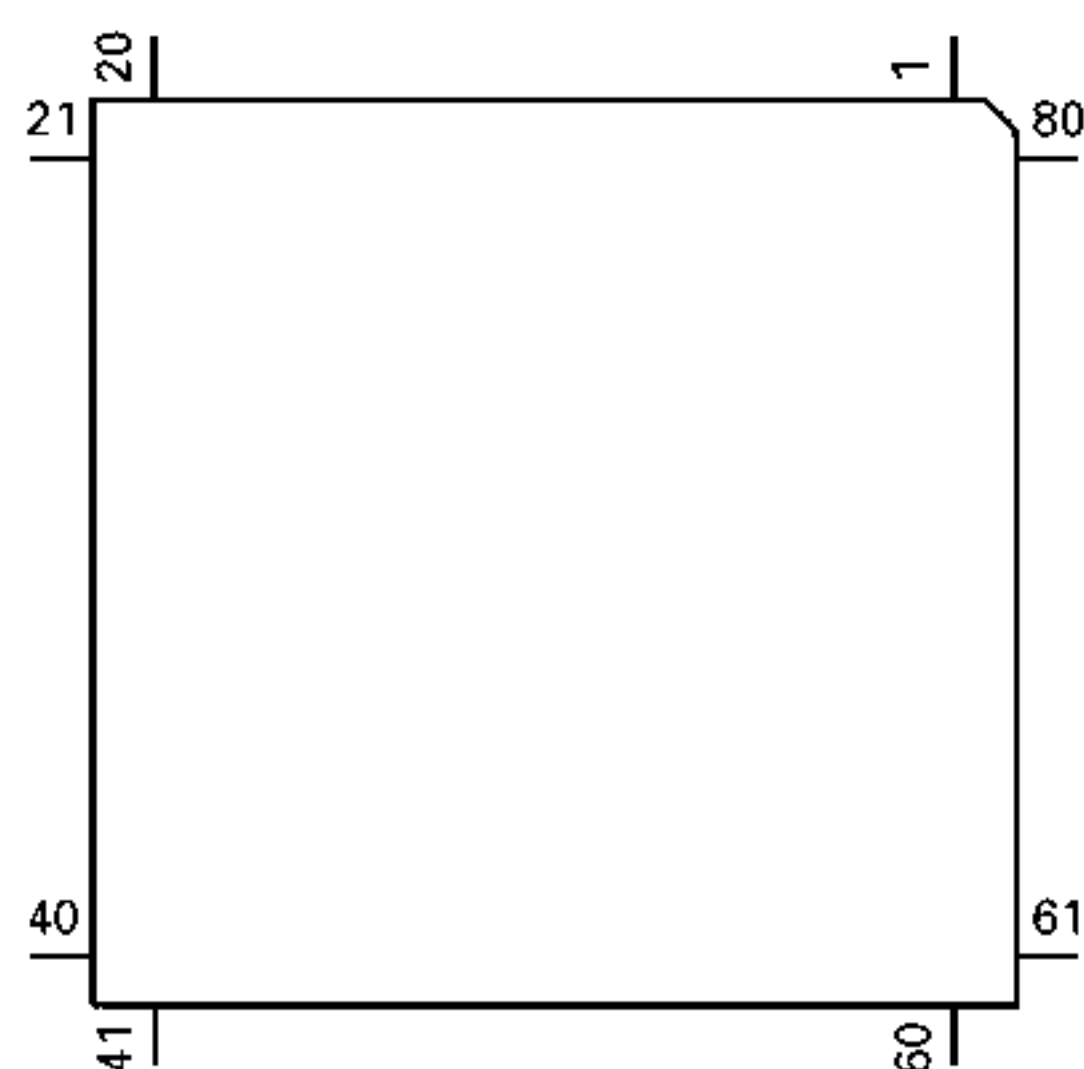

IC's marked by* are MOS type.

Be careful in handling them because they are very liable to be damaged by electrostatic induction.

Format	Meaning
C	C MOS
N	N Channel open drain

● Pin Functions(PD6196A)

Pin No.	Pin Name	I/O	Function and Operation
1-5	SEG4-0	O	LCD segment output
6-9	COM3-0	O	Common driver output
10	V3		LCD bias power supply
11-14	KS4-1	O	Key strobe output
15,16	KD1,2	I	Key data input
17	REM	I	Remote control reception
18	SI	I	UART input
19	RST	I	System reset
20	SO	O	UART output
21	MODA		GND
22	X0		Crystal oscillator connection pin
23	X1		Crystal oscillator connection pin
24	VSS		GND
25,26	KD3,4	I	Key data input
27,28	KS6,5	O	Key strobe output
29-55	SEG39-13	O	LCD segment output
56	VCC		5V
57-64	SEG12-5	O	LCD segment output

*PD6196A

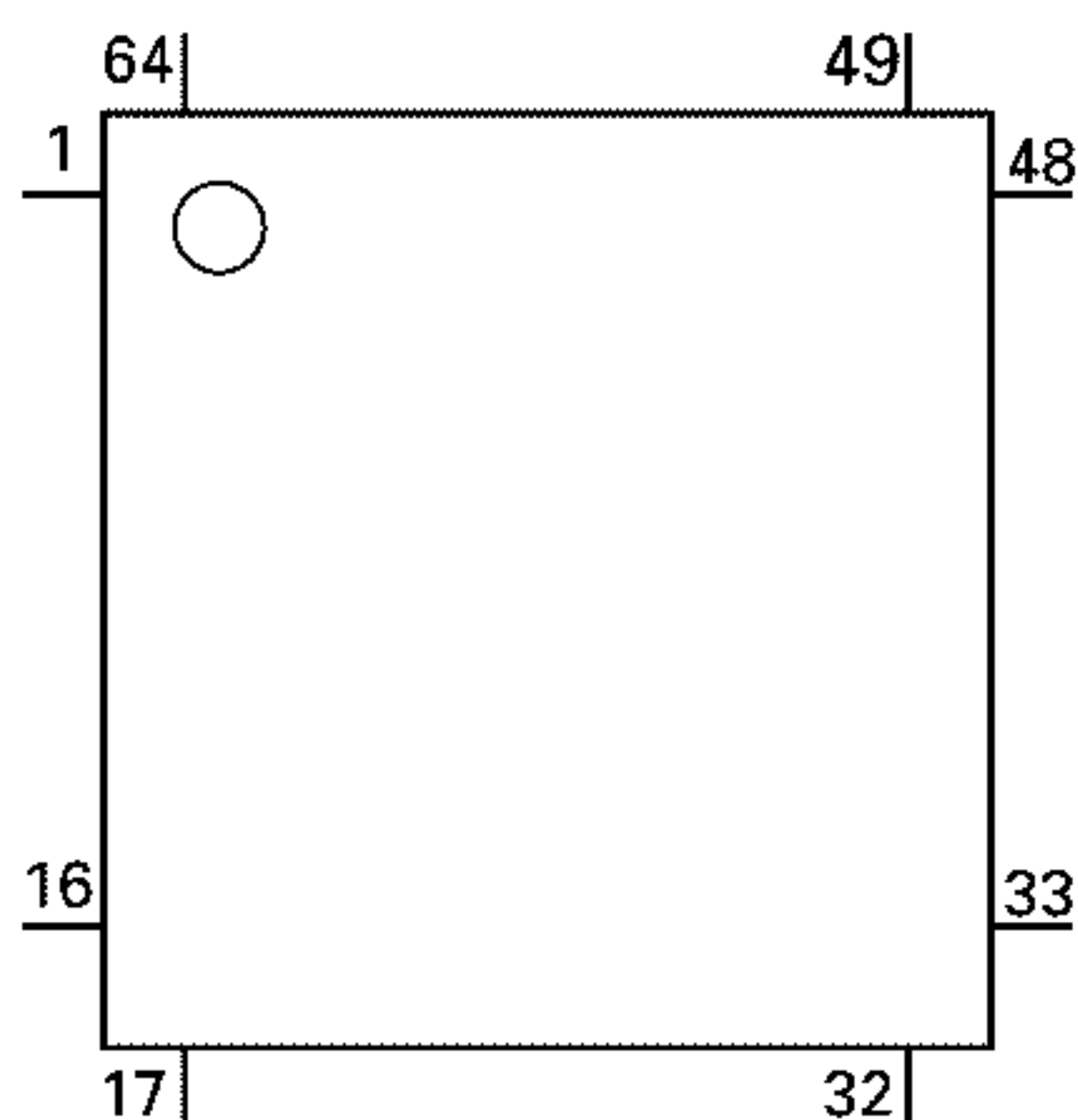

7.1.2 DISPLAY

● CAW1391

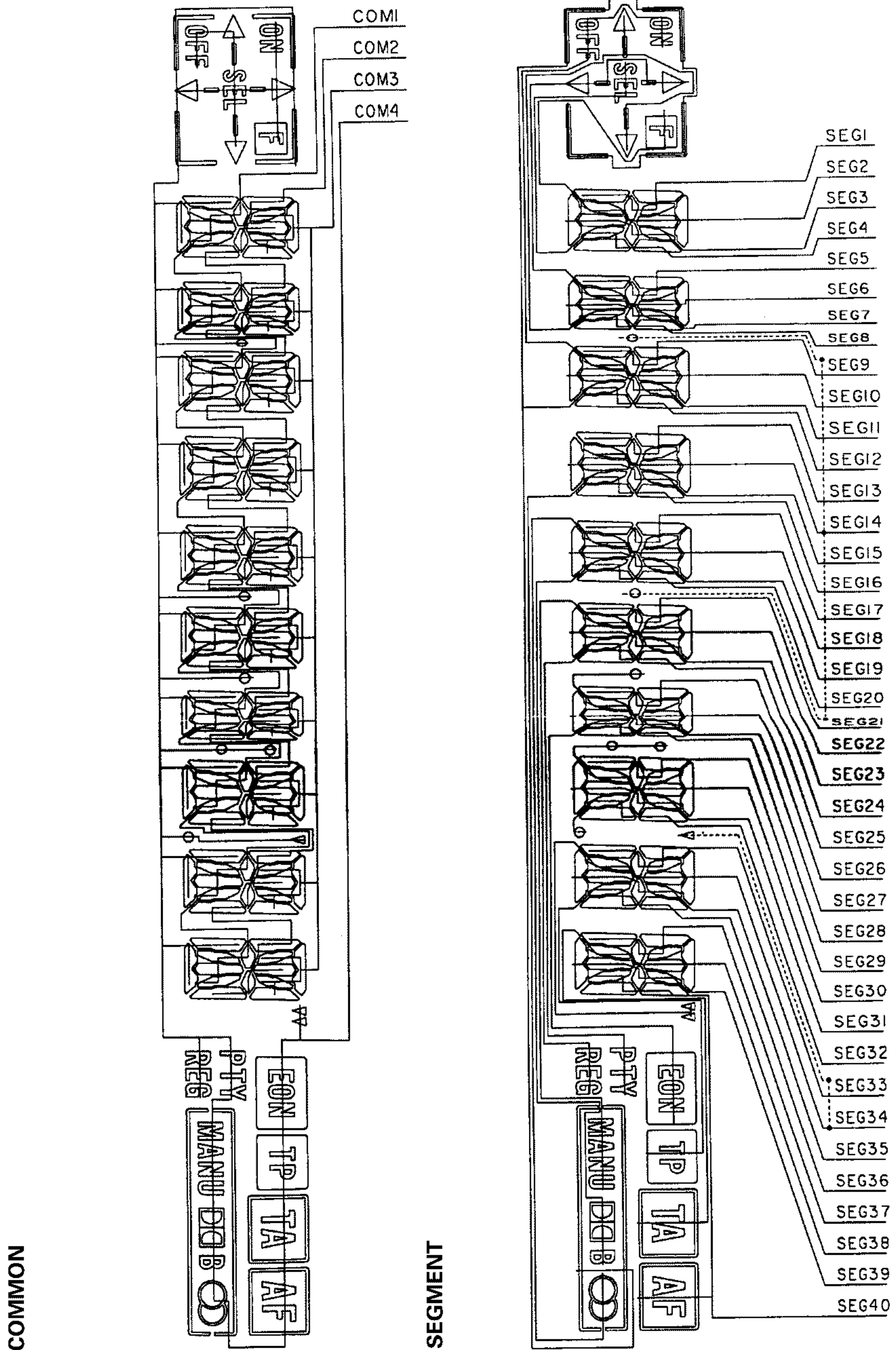

Fig. 16

7.2 DISASSEMBLY

● Removing the Case(not shown)

- 1.Remove the three screws.
- 2.Remove the Case.

● Removing the Cassette Mechanism Assy (not shown)

- 1.Remove the four screws.
- 2.Disconnect the connector, and then removing the Cassette Mechanism Assy.

● Removing the Grille Assy(Fig.17)

- 1.Disengage the stopper at two locations indicated by arrows.
- 2.Remove the Grille Assy.

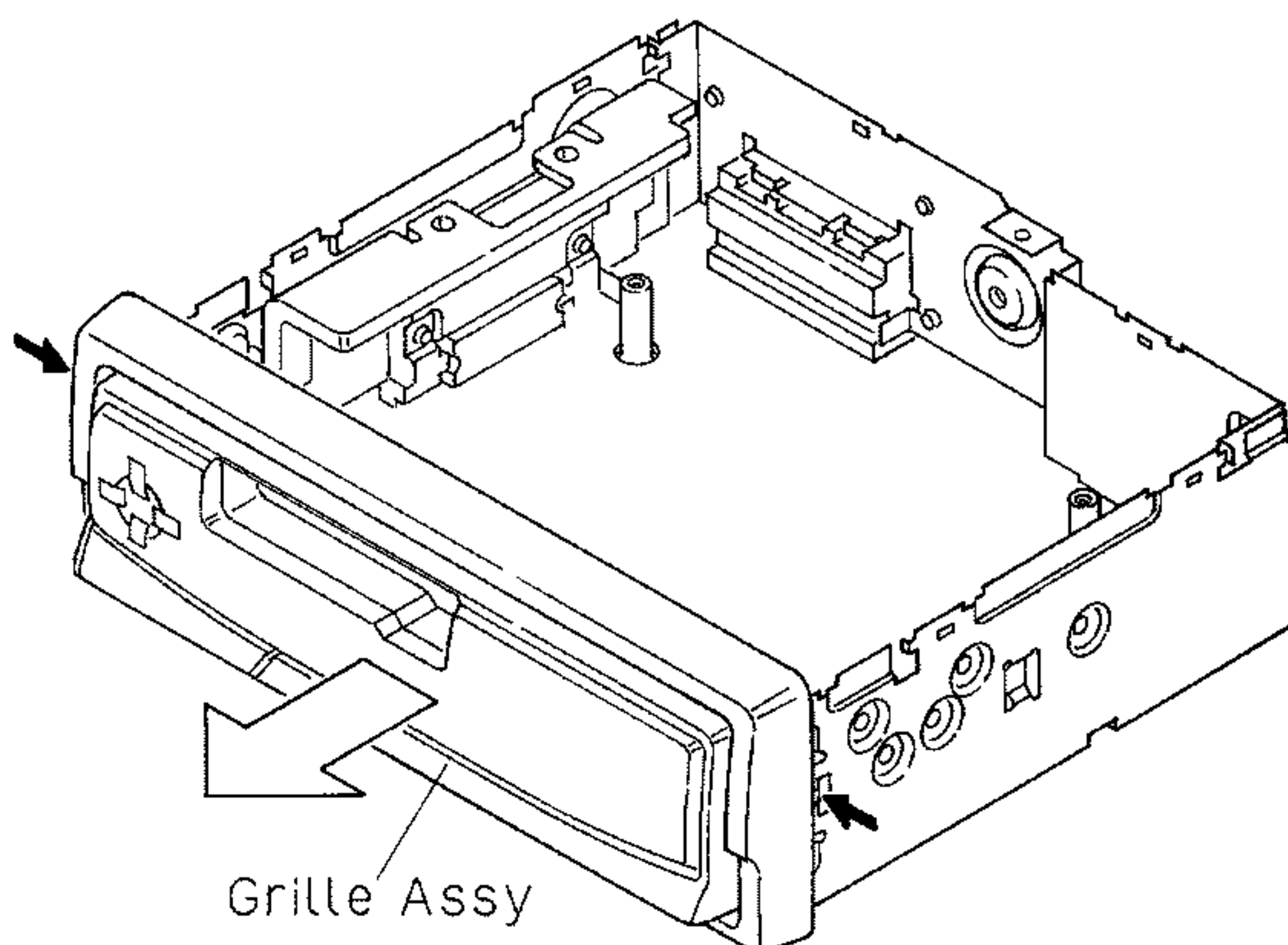

Fig. 17

● Removing the Tuner Amp Unit(Fig.18)

- 1.Removing the three screws A, two screws B and screw C.
- 2.Unbend the tabs at a location indicated by arrow until straight.
- 3.Remove the Tuner Amp Unit.

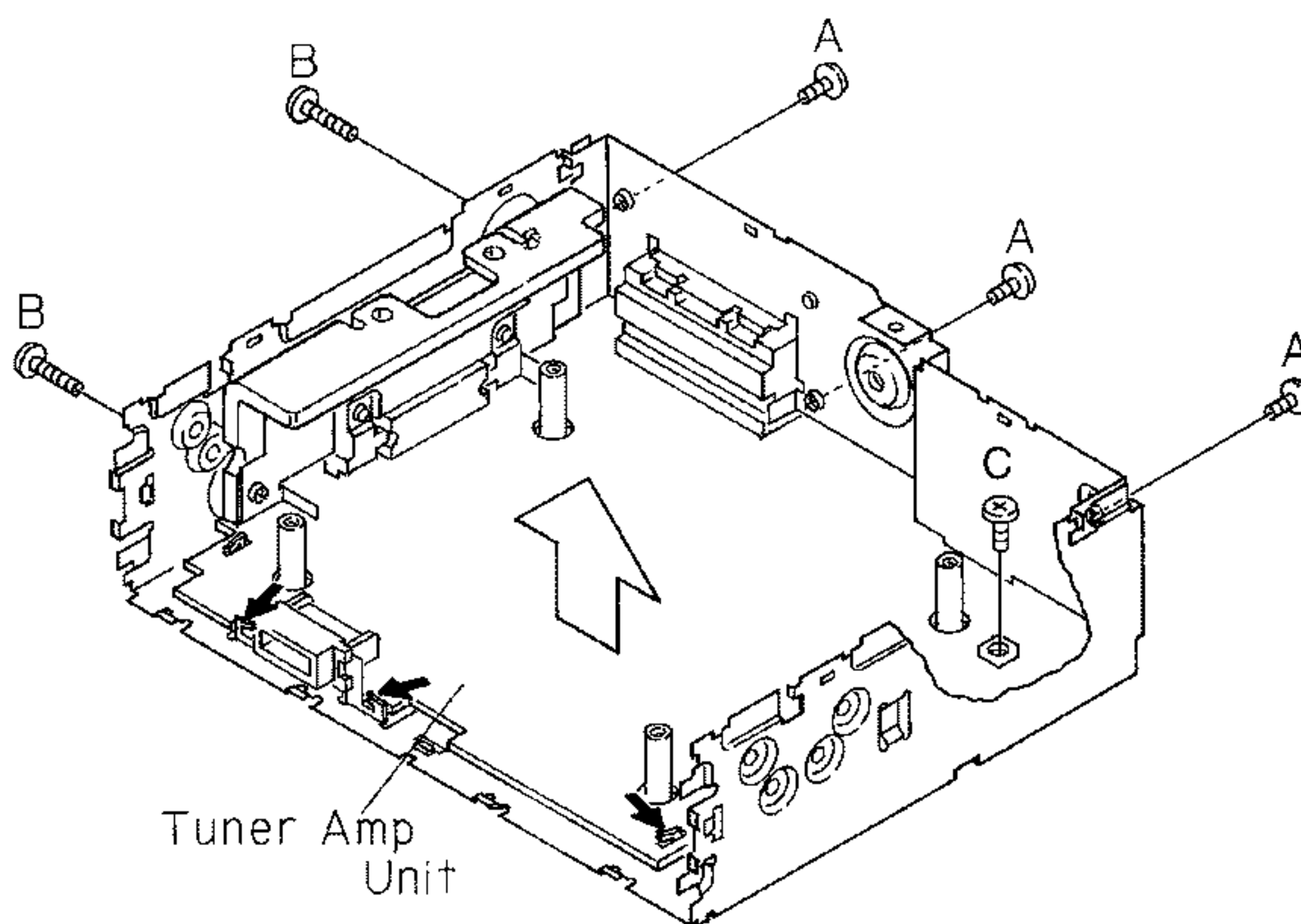

Fig. 18

7.3 BLOCK DIAGRAM

● KEH-2700R/X1M/EW

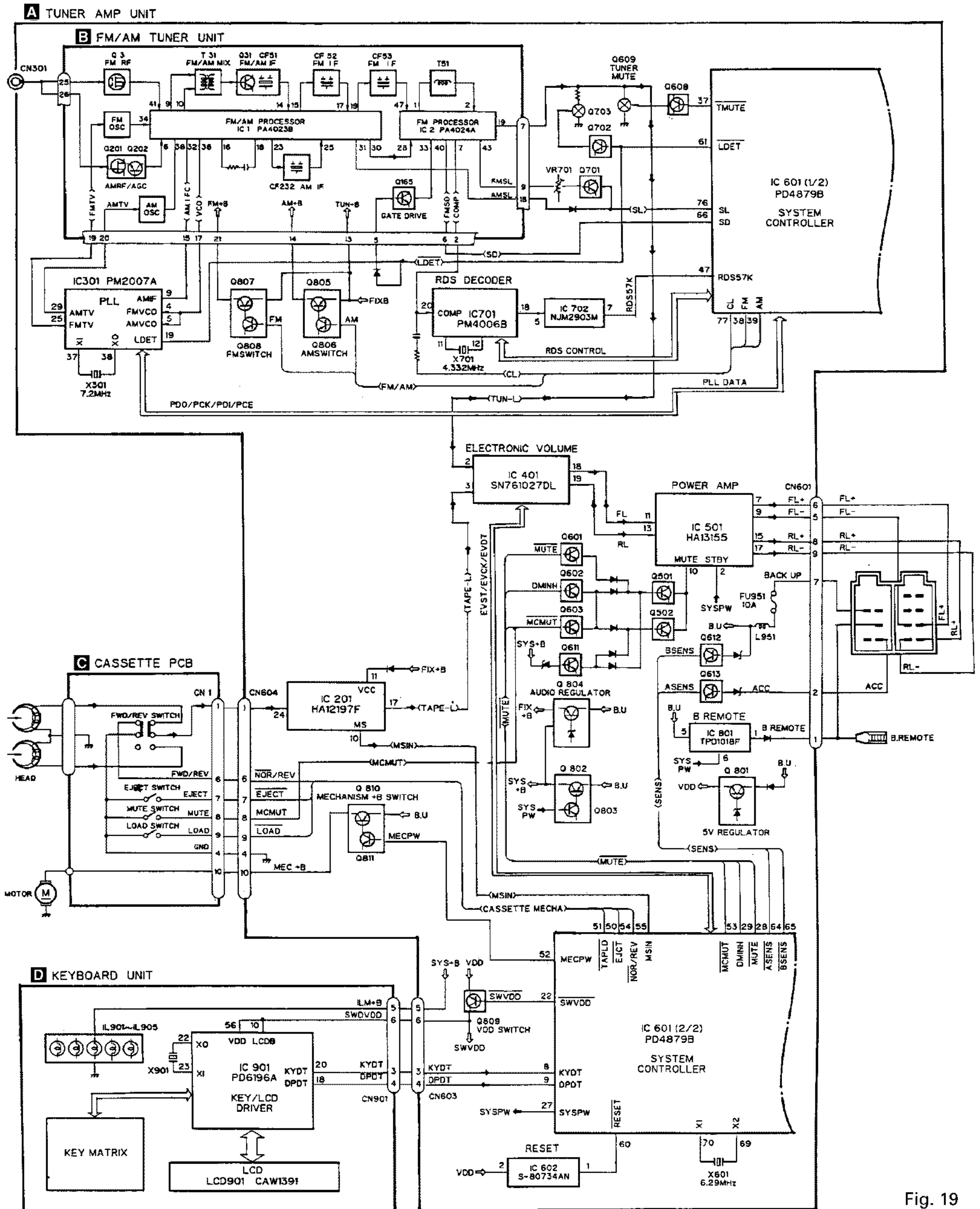

Fig. 19

8. OPERATIONS AND SPECIFICATIONS

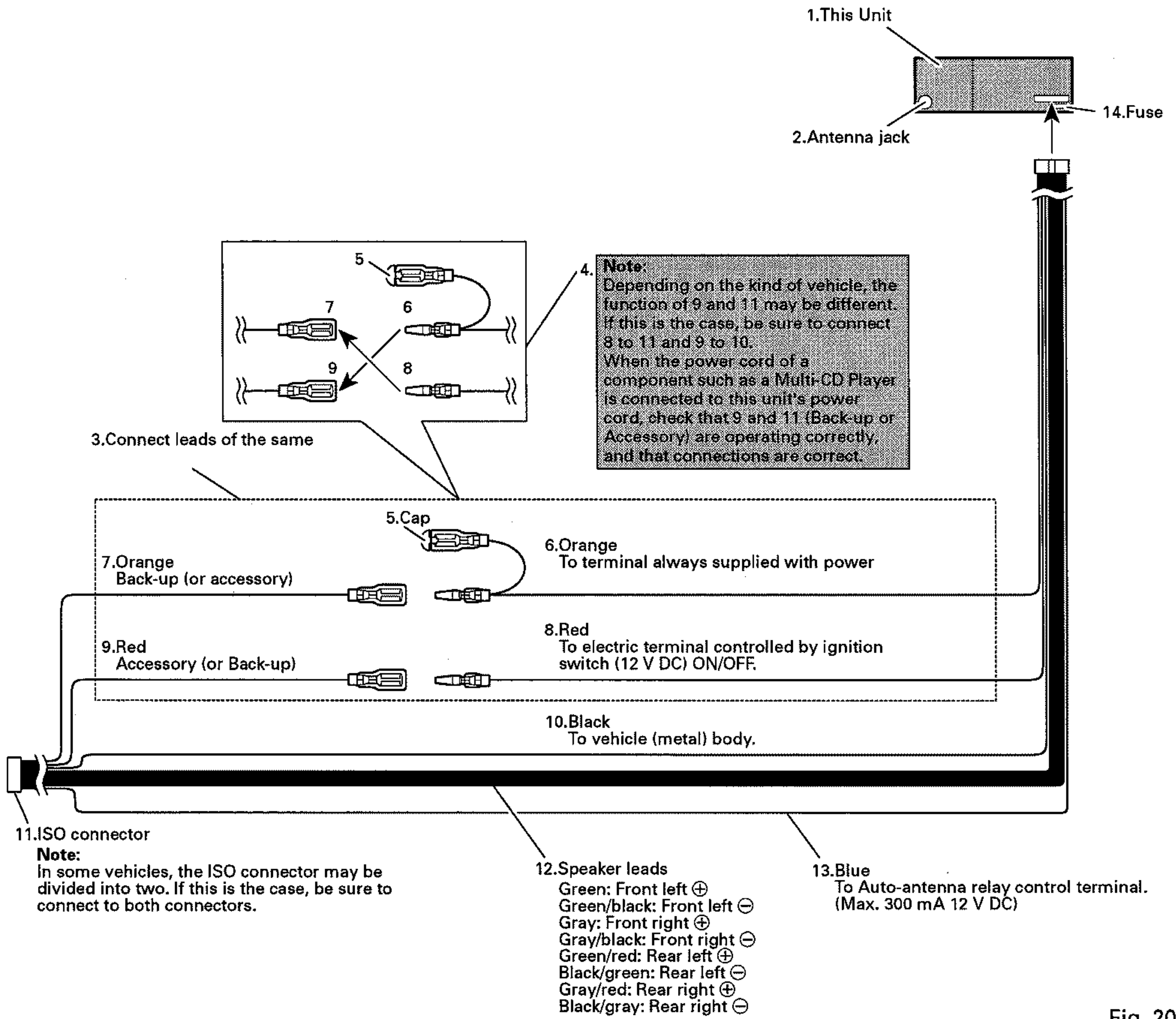

Fig. 20

8.1 OPERATIONS

Basic Operation

Switching Power On

- Select the desired source (such as the tuner).

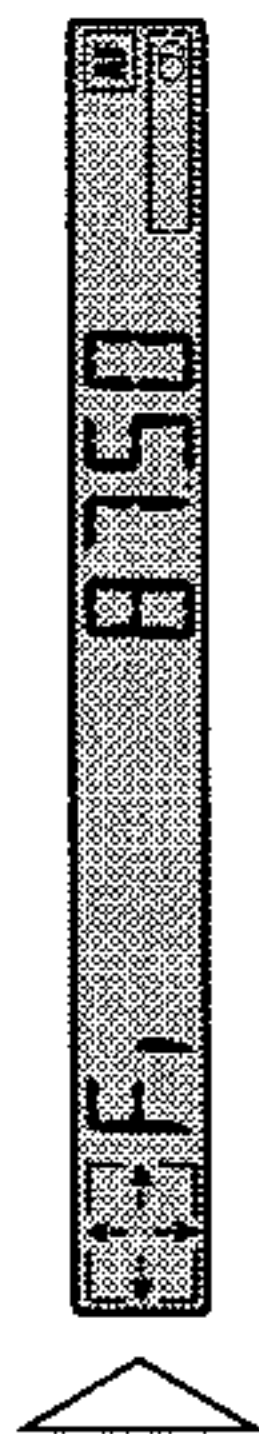
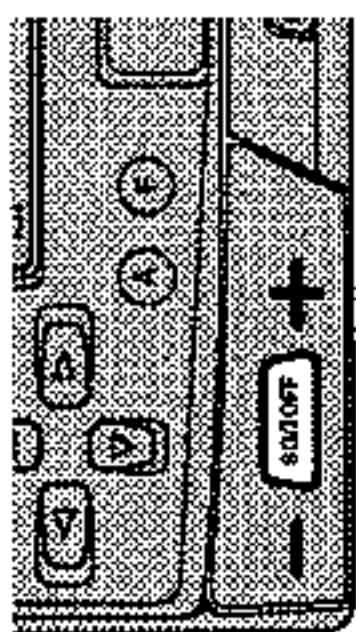

Each press of the SOURCE button selects the desired source in the following order:
Tuner → Tape

Note:

- The sound source will not change when a cassette tape is not set in this unit.

Switching Power Off

- Switch the sources OFF.

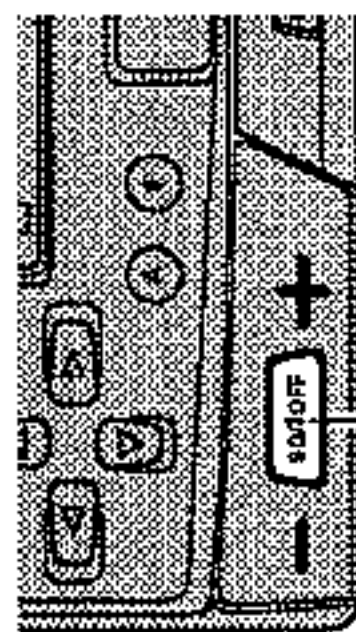

Hold for 1 second

Key Finder

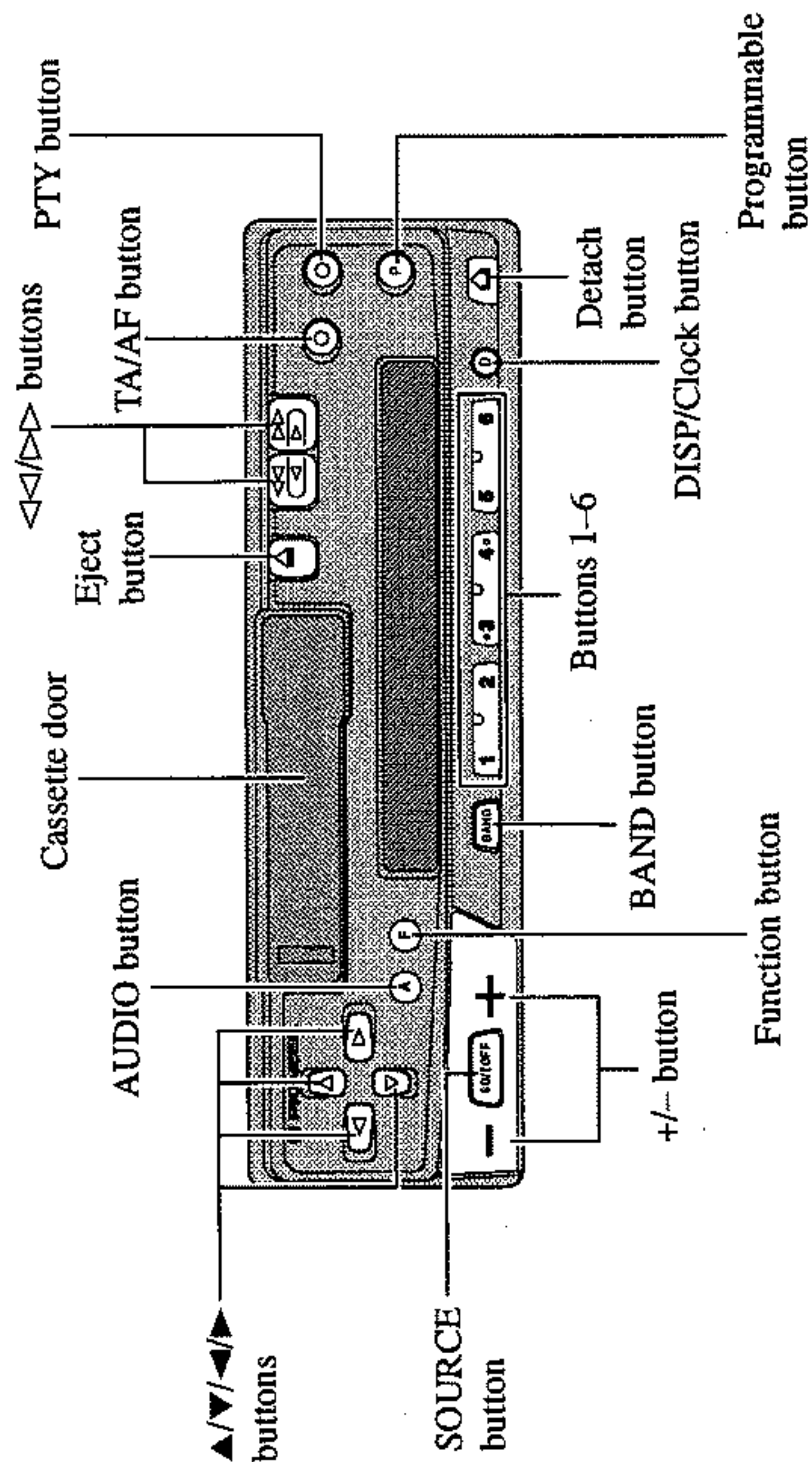

Tuner Operation

Basic Operation of Tuner

1. Select Tuner.

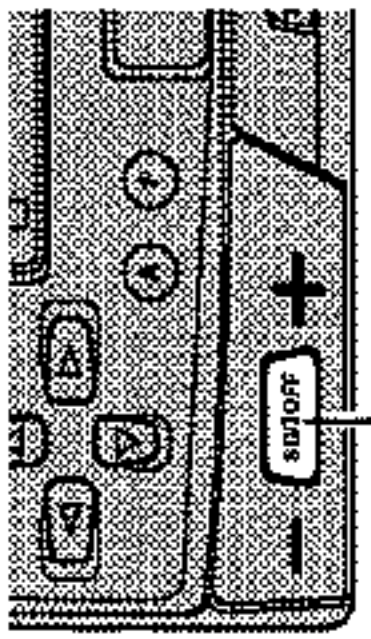

Each press changes the Source ...

The program service name or frequency appears on the display. ("O" indicator lights when a stereo station is selected.)

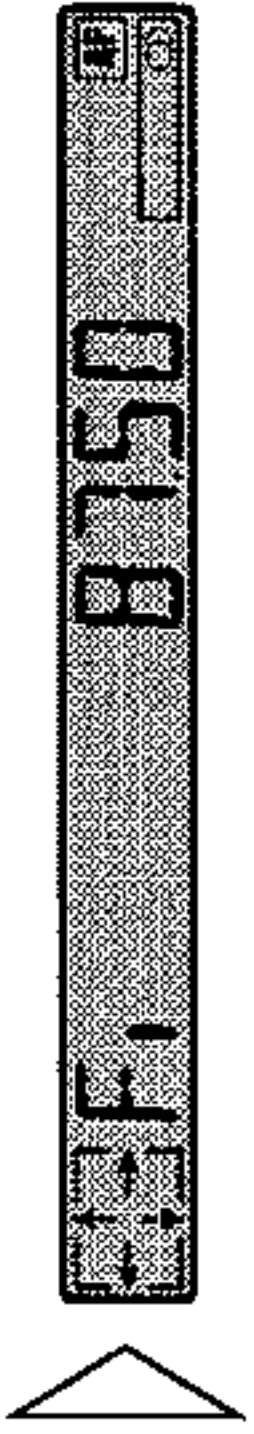

2. Select the desired band.

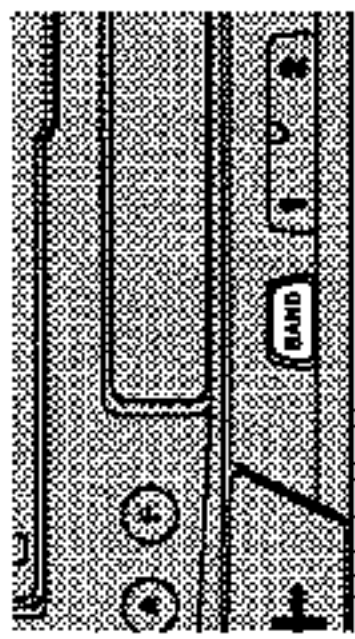

F1 → F11 → MW/LW

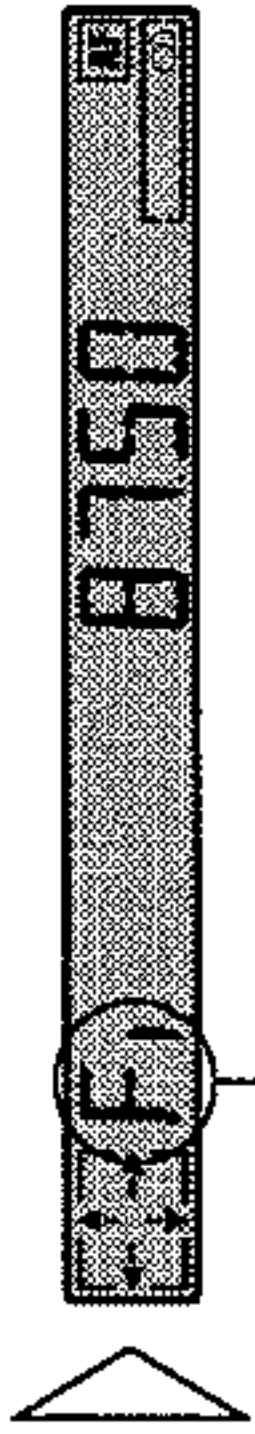

3. Tune the receiver to a higher or lower frequency.

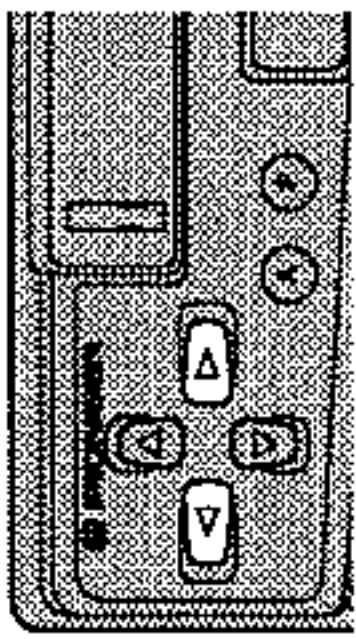

This product's tuner lets you select the tuning by changing the length of the time you press the button.

Manual Tuning (step by step)	0.3 seconds or less
Seek Tuning	0.3 – 2 seconds
Manual Tuning (continuously)	2 seconds or more

Note:

- To select a weak broadcasting station that cannot be tuned in with the Seek Tuning function, tune in with Manual Tuning.

Tuner Operation

4. Raise or lower the volume.

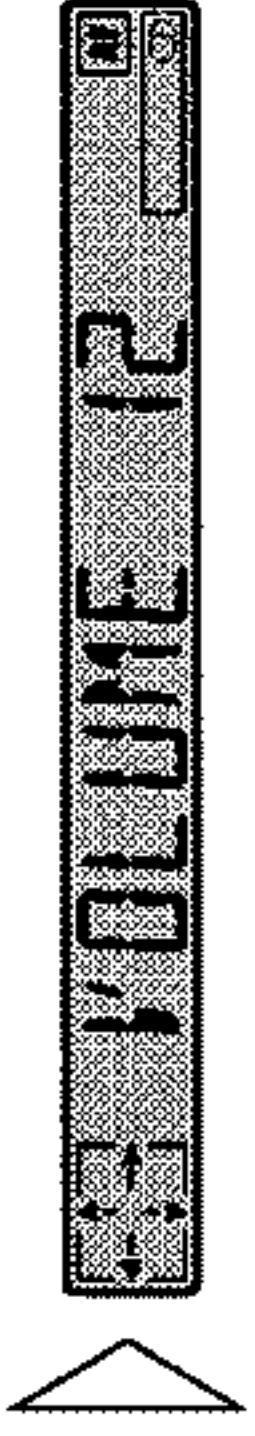
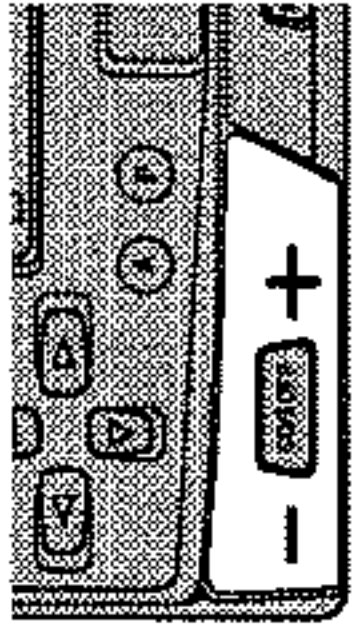

5. Turn the source OFF.

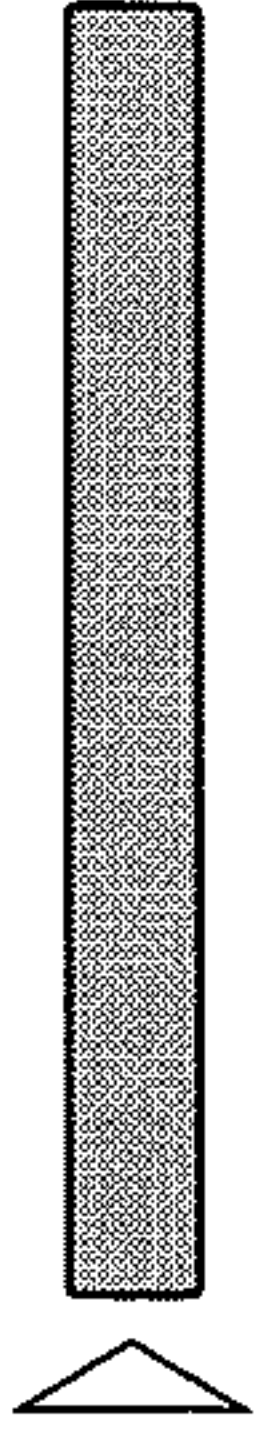
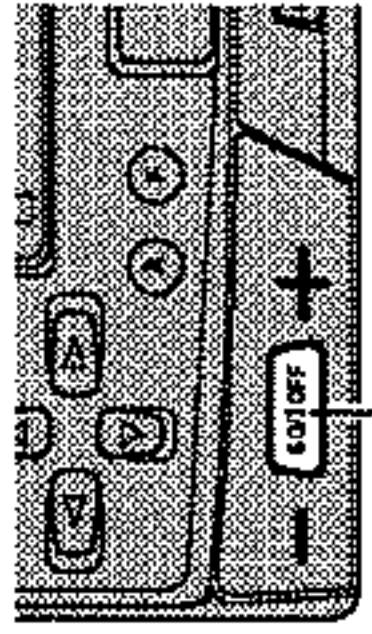

Hold for 1 second

Entering the Function Menu

In this menu you can select tuner functions.

Note:

- REG, TA, PTY, and AF are RDS functions. Refer to "Using RDS Function" for details and instructions on how to use these functions.

- Select the desired mode in Function Menu.

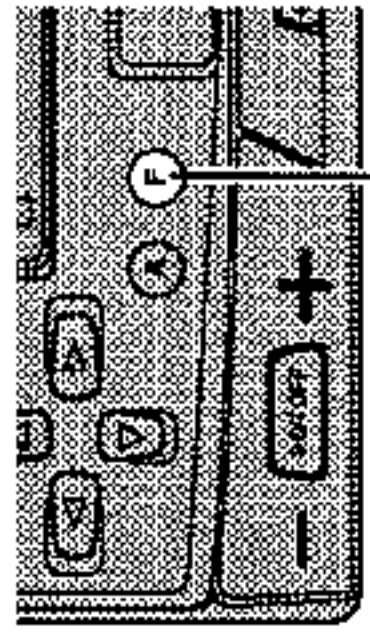

Each press changes the Mode ...

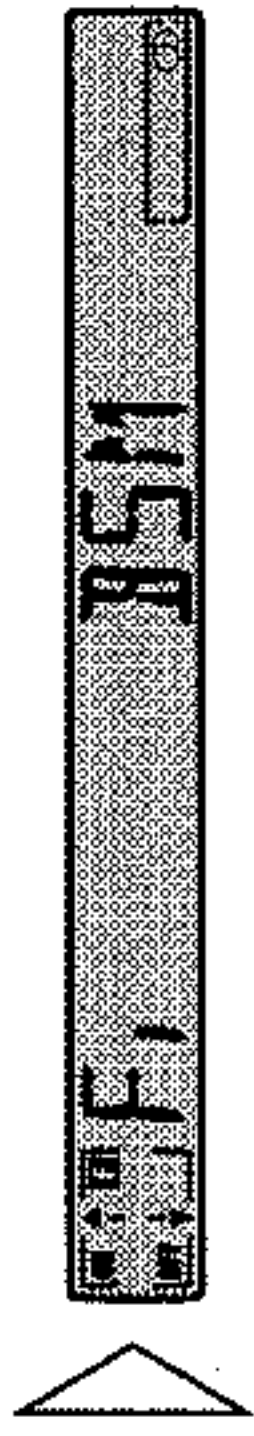

Each press of the Function button selects the mode in the following order:

BSM → REG → LOCAL → TA → PTY SELECT → AF

Note:

- You can cancel the Function Menu by pressing the BAND button.
- After selecting the Function Menu, if you do not perform an operation within about 30 seconds, the Function Menu is automatically canceled.

Tuner Operation

Preset Memory

The Preset Memory function stores stations in memory manually.

1. Select the station whose frequency you want to store in memory.
2. Press one of buttons 1-6 for 2 seconds or longer to store the desired stations.

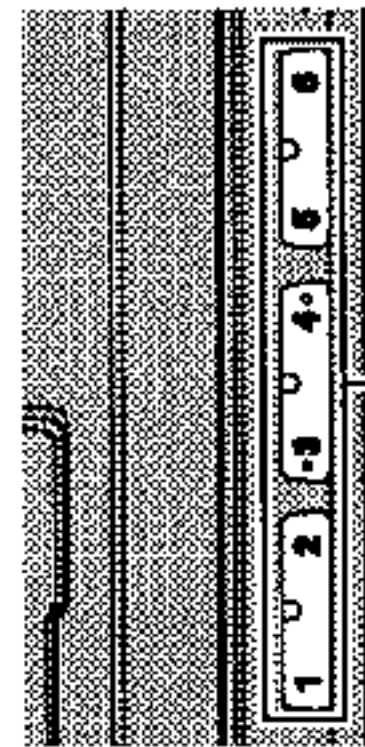

Hold for 2 seconds

The station is stored in memory under the selected button.

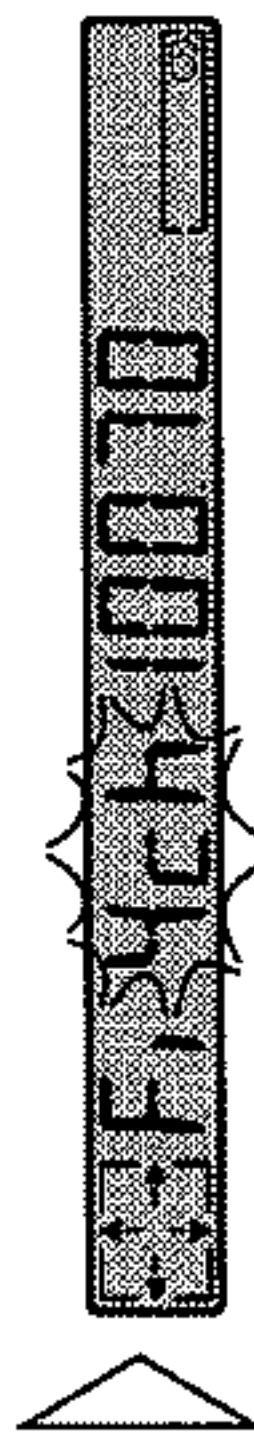

Recalling Preset Stations

There are two ways to recall preset stations.

- **Direct Recall**
 - Press one of buttons 1-6 to recall a station preset under that button.
- **Sequential Recall**
 - Recall a station preset under button 1-6.

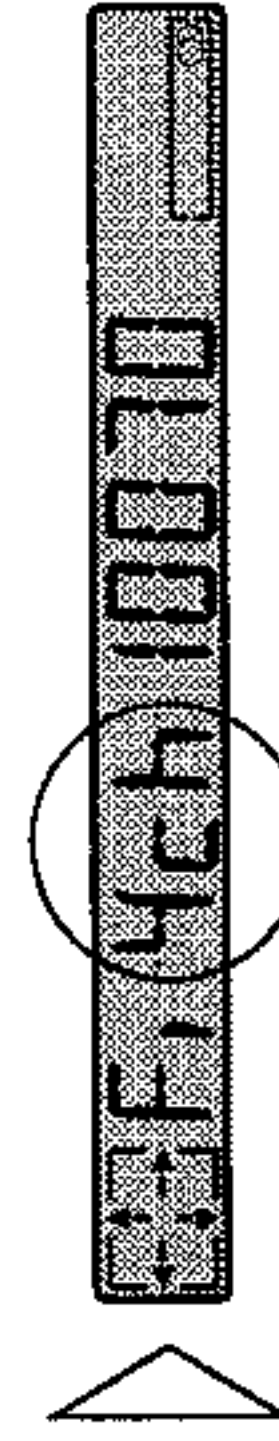
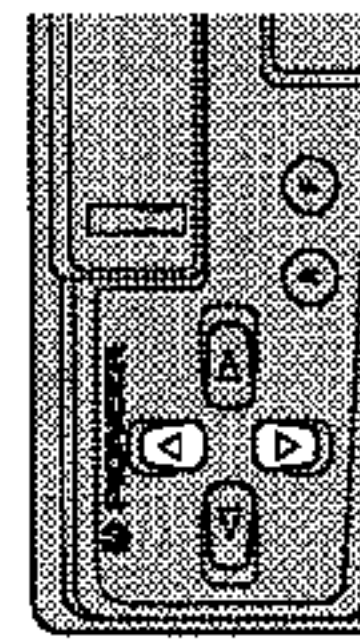
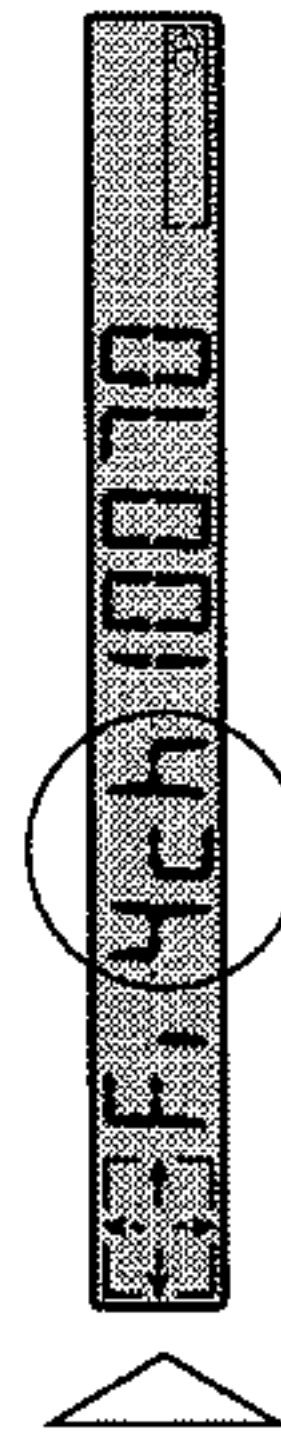
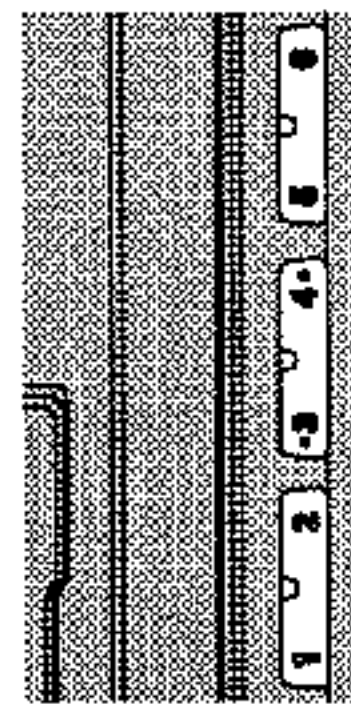

Using the Cassette Player

Basic Operation of Cassette Player

1. Insert the cassette tape.

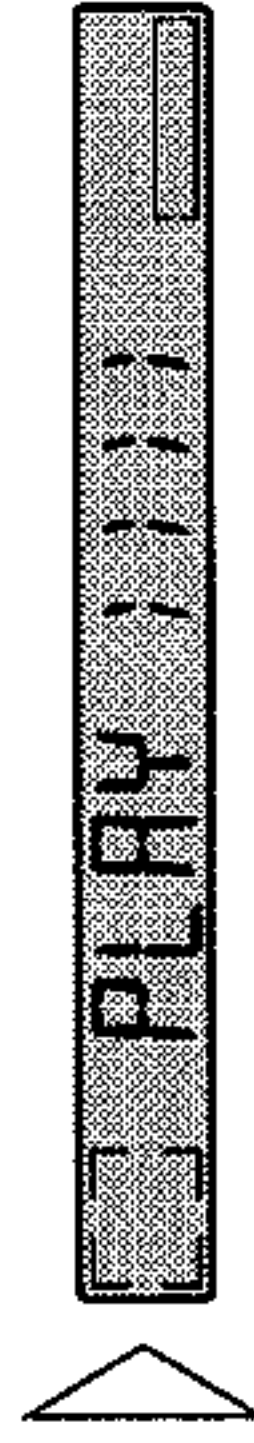
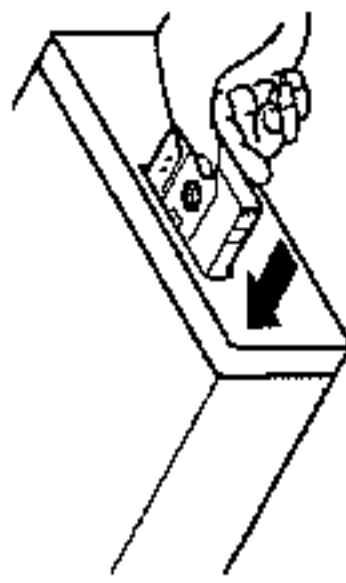

2. Switch tape playback from side A to side B, or vice versa.

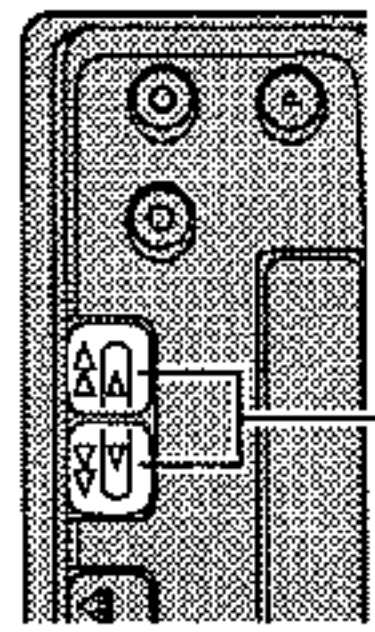

Same Time

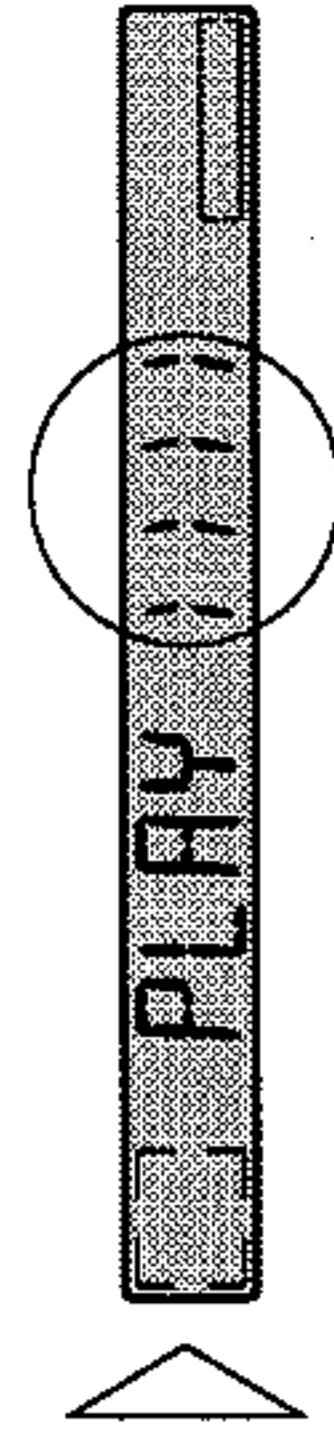

3. Raise or lower the volume.

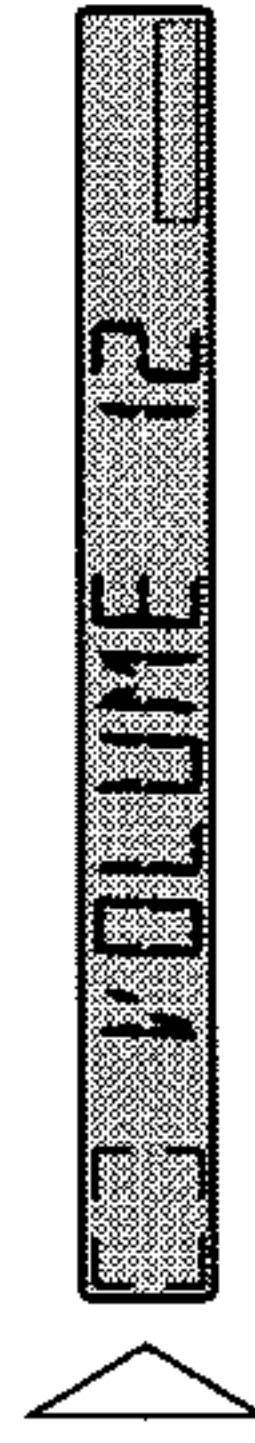
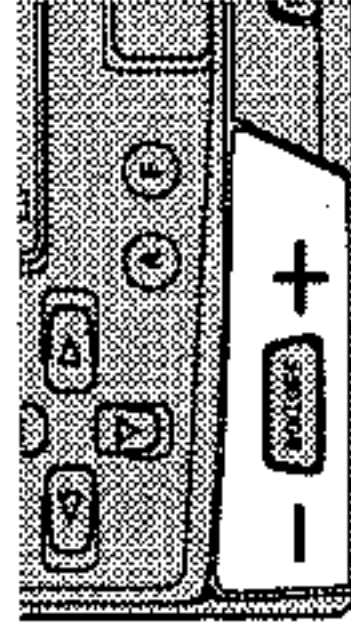

4. Remove the cassette tape.

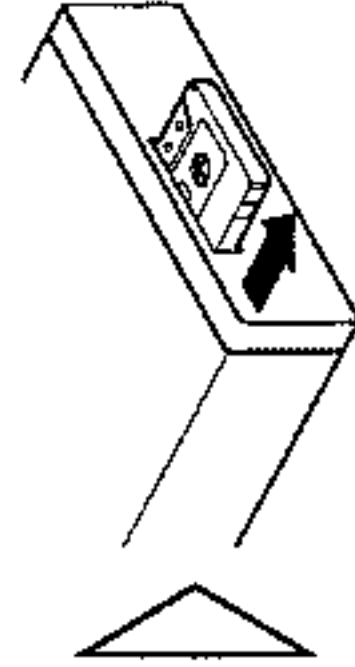
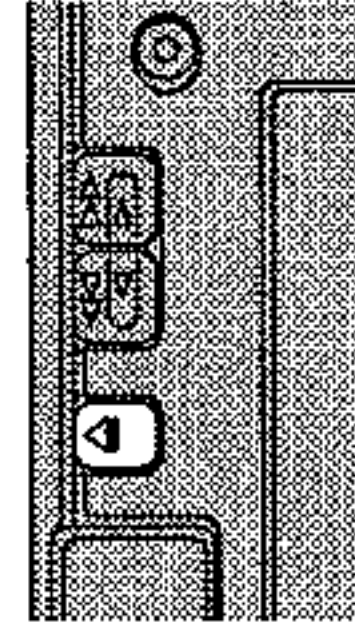

Note:

- The Tape function can be turned ON/OFF with the cassette tape remaining in this product.

Using the Cassette Player

Fast Forward/Rewind

■ Fast Forward

While “<->” is displayed, the system fast-forwards the cassette tape to the end of the current side.

- **Fast-forward the cassette tape by pressing the button for the same direction as the tape play indicator.**

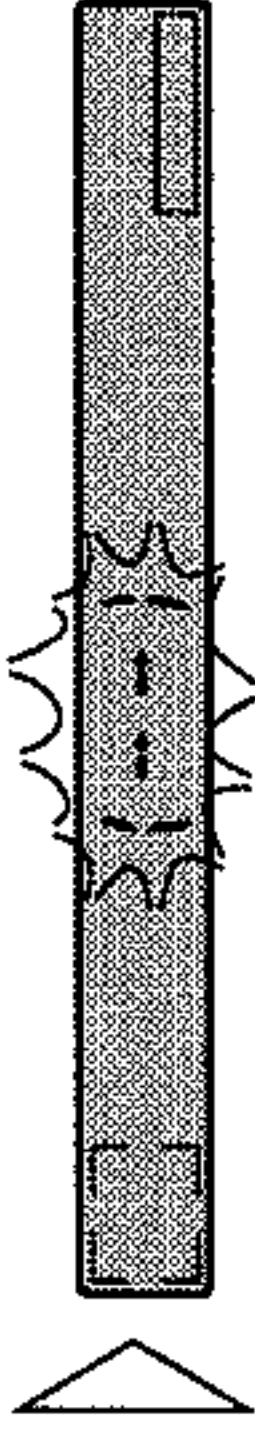
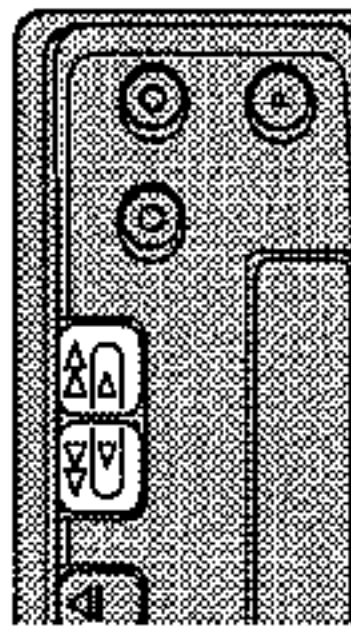

■ Rewind

While “<->” is displayed, the system rewinds the cassette tape to the beginning of the current side.

- **Rewind the cassette tape by pressing the button for the opposite direction as the tape play indicator.**

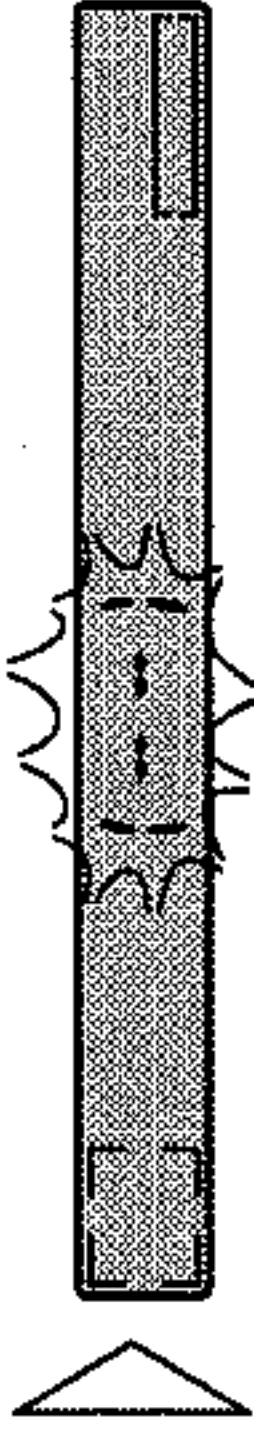
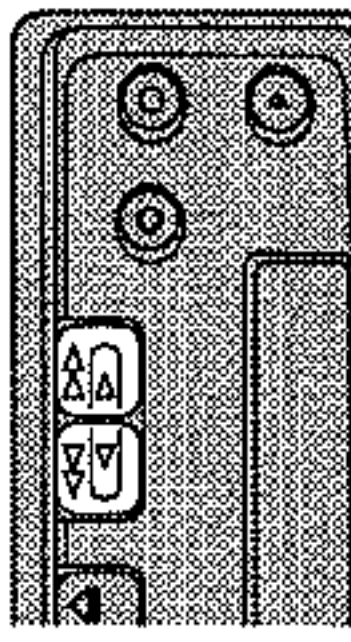

Entering the Function Menu

In this menu you can select Tape functions.

- **Select the Radio Intercept mode in Function Menu.**

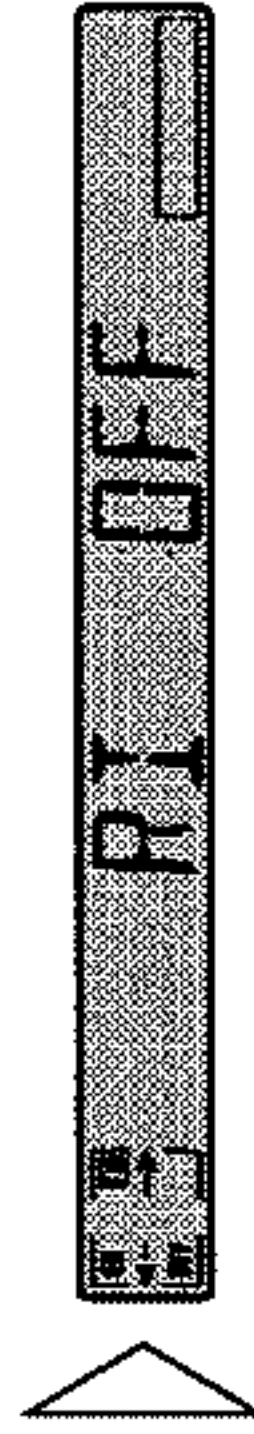
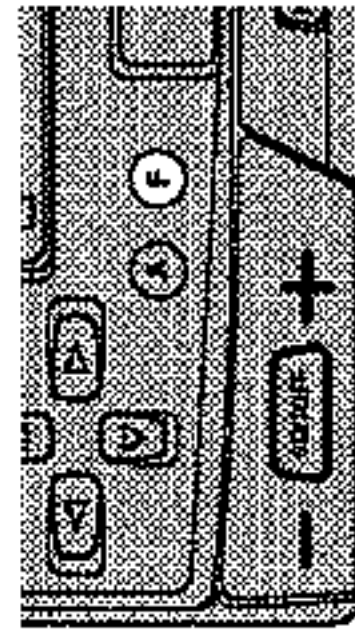

Note:

- You can cancel the Function Menu by pressing the BAND button.
- After selecting the Function Menu, if you do not perform an operation within about 30 seconds, the Function Menu is automatically canceled.
- This unit's cassette Function Menu enables Radio Intercept mode ON/OFF switching only. If you press the Function button for 2 seconds or more and select the Programmable button Setting mode, you can memorize the Radio Intercept mode ON/OFF setting beforehand. However, switching between ON and OFF is not possible with the Programmable button.
- You can cancel the Programmable button setting mode by pressing the BAND button.

Audio Adjustment

Bass/Treble Adjustment

This product is equipped with two tone adjustment modes, the Bass Adjustment and Treble Adjustment modes.

1. **Select “Bass Adjustment mode” or “Treble Adjustment mode”.**
After adjustment use the BAND button to return to the normal display.
2. **Increase or decrease the intensity of the bass or treble, whichever is selected.**

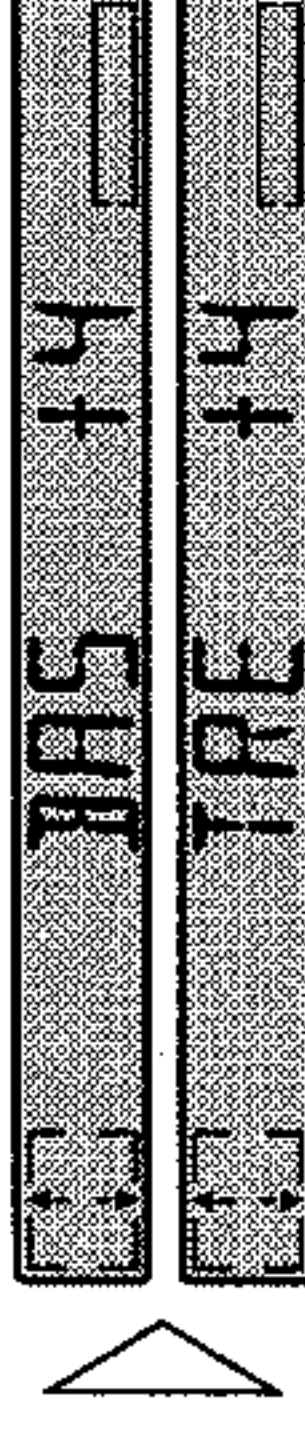
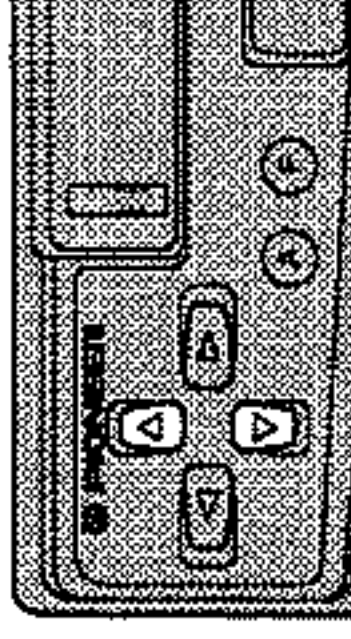

The display shows “+6” – “-6”.

3. **Repeat steps 1 – 2 above for the other Bass or Treble Adjustment mode.**

8.2 SPECIFICATIONS

Specifications

General

Power source 14.4 V DC (10.8 – 15.1 V allowable)
 Grounding system Negative type
 Max. current consumption 8.5 A
 Dimensions
 (mounting size) 178 (W) × 50 (H) × 150 (D) mm
 (front face) 188 (W) × 58 (H) × 19 (D) mm
 Weight 1.2 kg

Amplifier

Maximum power output 35 W × 4
 Continuous power output 22 W × 4
 (DIN45324, +B=14.4 V)
 Load impedance 4 Ω (4 – 8 Ω allowable)
 Tone controls
 (Bass) ±12 dB (100 Hz)
 (Treble) ±12 dB (10 kHz)
 Loudness contour +10 dB (100 Hz), +7 dB (10 kHz)
 (volume: –30 dB)

Cassette player

Tape Compact cassette tape (C-30 – C-90)
 Tape speed 4.76 cm/sec. (+0.14 cm/sec., –0.05 cm/sec.)
 Fast forward/rewinding time Approx. 90 sec. for C-60
 Wow & flutter 0.13% (WRMS)
 Frequency response 40 – 14,000 Hz (±3 dB)
 Stereo separation 45 dB
 Signal-to-noise ratio 52 dB (IEC-A network)

FM tuner

Frequency range 87.5 – 108 MHz
 Usable sensitivity
 11 dBf (1.0 μV/75 Ω, mono, S/N: 30 dB)
 50 dB quieting sensitivity 16 dBf (1.7 μV/75 Ω, mono)
 Signal-to-noise ratio 70 dB (IEC-A network)
 Distortion 0.3% (at 65 dBf, 1 kHz, stereo)
 Frequency response 30 – 15,000 Hz (±3 dB)
 Stereo separation 40 dB (at 65 dBf, 1 kHz)

MW tuner

Frequency range 531 – 1,602 kHz
 Usable sensitivity 18 μV (25 dB) (S/N: 20 dB)
 Selectivity 50 dB (±9 kHz)

LW tuner

Frequency range 153 – 281 kHz
 Usable sensitivity 30 μV (30 dB) (S/N: 20 dB)
 Selectivity 50 dB (±9 kHz)

Note:

- Specifications and the design are subject to possible modification without notice due to improvements.