

• KEH-P7200RDS/EW

Manual



MULTI-CD CONTROL FM/MW/LW TUNER DECK AMPLIFIER

KEH-P7200RDS

EW

KEH-P7100RDS

EW

KEH-P6200RDS

EW

KEH-P6100RDS

EW

KEH-P25RDS

EW

KEH-P15RDS

EW

NOTE:

- Dolby noise reduction manufactured under license from Dolby Laboratories Licensing Corporation.
"Dolby" and the double-D symbol are trademarks of Dolby Laboratories Licensing Corporation.
- See the separate manual CX-631(CRT1640) for the cassette mechanism description.
- The cassette mechanism employed in this model is one of 2L mechanism series.

CONTENTS

1. SPECIFICATIONS	2
2. OPERATION AND CONNECTION.....	2

www.DataSheet4U.com

1. SPECIFICATIONS

General

Power source 14.4 V DC (10.8 — 15.6 V allowable)
 Grounding system Negative type
 Max. current consumption 8.5 A
 Dimensions (chassis) 178 (W) × 50 (H) × 150 (D) mm
 (front face) 188 (W) × 58 (H) × 19 (D) mm
 Weight 1.3 kg

Amplifier

Maximum power output 35 W × 4 (EIAJ)
 Continuous power output 22 W × 4 (DIN 45324, +B = 14.4 V)
 Load impedance 4 Ω (4 — 8 Ω allowable)
 Preout output level/output impedance 500 mV/1 kΩ
 Tone controls (bass) ±12 dB (100 Hz)
 (treble) ±12 dB (10 kHz)
 Loudness contour +10 dB (100 Hz), +7 dB (10 kHz)
 (Volume: -30 dB)

Tape player

Tape Compact cassette tape (C-30 — C-90)
 Tape speed 4.76 cm/sec. (+0.14 cm/sec., -0.05 cm/sec.)
 Fast forward/rewind time Approx. 100 sec. for C-60
 Wow & flutter 0.09 % (WRMS)
 Frequency response Metal: 30 — 19,000 Hz (±3 dB)
 Stereo separation 45 dB
 Signal-to-noise ratio
 Metal: Dolby B NR IN: 67 dB (IEC-A network)
 Dolby NR OUT: 61 dB (IEC-A network)

FM tuner

Frequency range 87.5 — 108 MHz
 Usable sensitivity 11 dBf (1.0 μV/75 Ω, mono, S/N: 30 dB)
 50 dB quieting sensitivity 16 dBf (1.7 μV/75 Ω, mono)
 Signal-to-noise ratio 70 dB (IEC-A network)
 Distortion 0.3 % (at 65 dBf, 1 kHz, stereo)
 Frequency response 30 — 15,000 Hz (±3 dB)
 Stereo separation 40 dB (at 65 dBf, 1 kHz)

MW tuner

Frequency range 531 — 1,602 kHz
 Usable sensitivity 18 μV (25 dB) (S/N: 20 dB)
 Selectivity 50 dB (±9 kHz)

LW tuner

Frequency range 153 — 281 kHz
 Usable sensitivity 30 μV (30 dB) (S/N: 20 dB)
 Selectivity 50 dB (±9 kHz)

Note:

Specifications and the design are subject to possible modification without notice due to improvements.

2. OPERATION AND CONNECTION

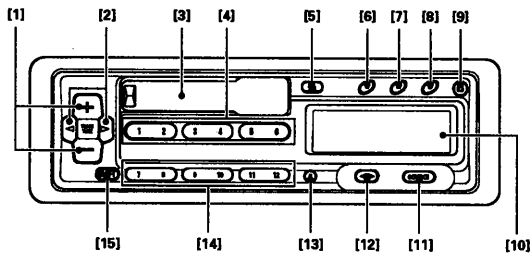

Fig. 1

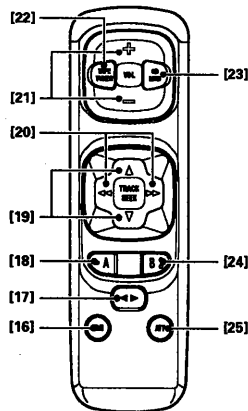

Fig. 2

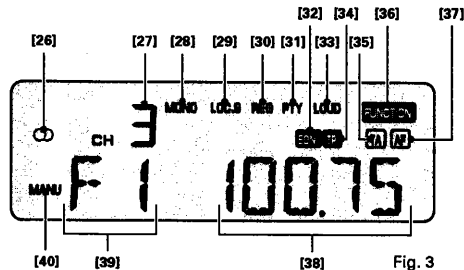

Fig. 3

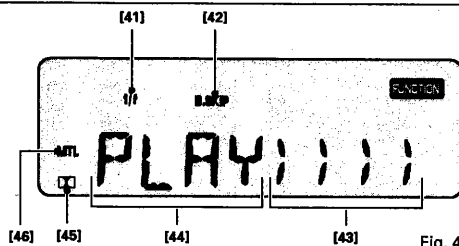

Fig. 4

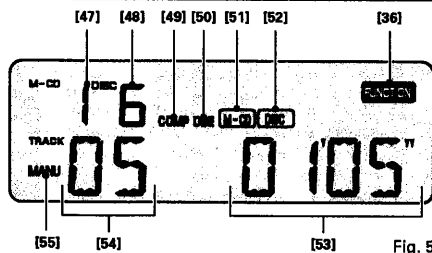



Fig. 5

Adjusting Volume and Tone

Parts Identification

Fig. 1

- [1] Volume/Audio adjustment
- [3] Cassette door
- [5] Eject
- [10] Display
- [11] Source selector
- [14]  AUX ON/OFF
- [15] Shift/Source level adjuster

Switching Power On

Radio

Press button [11] to switch the tuner power on. Press button [11] again to switch the power off.

Tape

Insert the cassette tape through the cassette door [3], and the power will be automatically turned on to start the tape being played back. To eject the tape, press button [5].

Changing the Source

When the cassette tape is inserted, the source changes at each press of the button [11]: Tape → Radio → OFF.

When an optional multi-play CD player (CDX-P1210, CDX-P610) is connected to your unit, the source changes as follows: Tape → Radio → Multi-play CD player → OFF.

If another audio component is connected to the IP-BUS terminal with an optional conversion cord, set the AUX to ON by doing as follows. Hold down button  in Bank [14] and set the

ignition switch from OFF to ON.

In this case, the source changes as follows: Tape → Radio → (Multi-play CD player) → AUX → OFF

Adjusting Audio

Press button [1] to adjust the volume. Each press of button [15] changes the display and the function of button [1] as follows: Volume → Fader (Balance) → Bass (Treble) → Loudness (ON/OFF) → F. I. E. mode.

- If no operations are performed within 8 seconds, adjustment modes are canceled. Make adjustments within 8 seconds.
- If the (◀) or (▶) side of button [2] is pressed when "FAD" is shown on the display, it changes to "BAL", and the balance can be adjusted. To switch from Balance to Fader, press the (+) or (-) side of button [1], and the display and button [1] function becomes Fader.
- When "BAS" is indicated on the display, press the (▶) side of button [2] to switch to "TRE". When "TRE" is displayed, press the (◀) side of button [2] to switch to "BAS".
- When you're adjusting fader, balance, bass or treble settings, the indicator will stop at the center setting.

Adjusting Volume

Pressing the (+) side of button [1] increases the volume, while the (-) side decreases it. (Display shows "VOL 00" ~ "VOL 30".)

- *When driving your vehicle, be sure to keep the volume of the unit set low enough to allow you to hear sounds coming from outside.*

Adjusting the Fader

When you press the (+) side of button [1], the front speaker volume increases gradually while the rear speaker volume decreases. When you press the (-) side of button, the rear speaker volume increases gradually while the front speaker volume decreases. (Display shows "FAD F15" ~ "FAD R15".)

- Please set "FAD 0" when using 2 speaker system.

Adjusting Balance

Pressing the (◀) side of button [2] shifts the balance to the left speaker, while the (▶) side shifts it to the right speaker. (Display shows "BAL L9" ~ "BAL R9".)

Adjusting Bass

Pressing the (+) side of button [1] increases bass, while the (-) side decreases bass. (Display shows "BAS -6" ~ "BAS +6".)

Adjusting Treble

Pressing the (+) side of button [1] increases treble, while the (-) side decreases treble. (Display shows "TRE -6" ~ "TRE +6".)

Using the Loudness Control

Pressing the (▶) side of button [2] turns the loudness function on, and "LOUD" [33] appears on the display. Pressing the (◀) side of button [2] turns it off. This loudness function supplements the insufficiency of low- and high-frequency ranges when the volume is low.

Switching the F. I. E. function

Pressing the (▶) side of button [2] turns the F. I. E. (Front Image Enhancer) function on. Pressing the (◀) side of button [2] turns it off. (refer to following section.)

Using the F. I. E. function

The F. I. E. (Front Image Enhancer) function cuts middle and high range frequency output from the rear speakers so that only low-range frequencies are output, for a simple way to enhance front imaging.

1. Press button [15] to switch to the F. I. E. mode (See "Adjusting Audio").
2. Press the (▶) side of button [2] to switch the F. I. E. mode ON.
3. Switch to the Fader mode, and balance front volume and rear bass volume (See "Adjusting the Fader").
4. Adjust volume and tone.

Note:

- *If you turn off the F. I. E. function, the rear speakers will output all sounds in addition to the bass sounds. This will cause a sudden increase in volume. Therefore, be sure to reduce the volume before turning off the F. I. E. function.*

Using Source Level Adjuster (KEH-P720ORDS, KEH-P710ORDS)

You may wish to adjust volume when you have changed the source to radio, tape, or CD or AUX or when you have changed the radio band from FM to MW/LW. You can do so on the basis of the FM volume as follows:

1. Use the button [11] to change the source. (In case of radio, change the band to MW/LW.)

2. Hold down the button [15] for about 2 seconds, and the display will show you the volume of the source. (Display shows "V -4" ~ "V +4".)

3. Pressing the (+) side of button [1] raises the volume and pressing the (-) side lowers it. About 8 seconds after completion of the adjustment, the display returns to what it was showing before the adjustment.

- No adjustment can be made when an FM station is tuned in.

Regarding the Cellular Telephone Muting

When a call is received or placed with a cellular telephone, the cellular telephone muting will turn ON. When the phone is hung up, the muting will be canceled.

- The volume is reduced to a low level.
- "CALL" will be displayed.
- The audio operation can not be done except volume control.

Using the Radio

Parts Identification

Fig. 1







- [2] Tuning
- [4] Preset
- [4]  Tuning Step
- [6] TA/PTY Alarm cancel
- [7] AF/REG
- [10] Display
- [11] Source selector
- [12] Band
- [13] Function ON/OFF
- [14] Preset (FM1)
- [14]  Frequency display/PTY display
- [14]  PTY
- [14]  Local Station
- [14]  Preset scan/Best Stations Memory (BSM)
- [14]  FM stereo, mono/Seek, Manual

Fig. 3

- [26] FM stereo
- [27] Preset number
- [28] FM mono
- [29] Local Station
- [30] REG
- [31] PTY
- [32] EON
- [34] TP
- [35] TA
- [36] Function Indicator
- [37] AF
- [38] Frequency
- [39] Band
- [40] Manual

Listening to the Radio

• Electronic Tuner

Frequency allocation differs depending upon the area. This unit has been designed in accordance with the frequency allocations for Western Europe, Asia, the Middle and Near East, Africa, Australia and Oceania. Use in other areas may result in improper reception of AM. The RDS function does not work in regions with no RDS broadcast services.

1. Press button [11] to switch the radio power on.
2. Press button [12] to select a band.

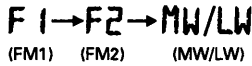

When the frequency is changed with button [2], MW (531 — 1,602 kHz) and LW (153 — 281 kHz) are switched automatically.

3. Use seek tuning to tune in a frequency. Ensure that "MANU" [40] is not indicated on the display. (When display indications are lit, press button [2] in Bank [14] for 2 seconds or more to switch OFF.) Press either the (◀) side or the (▶) side of button [2].

When the (▶) side is pressed, the tuner will automatically receive high frequencies. When the (◀) side is pressed, it will automatically receive low frequencies.

4. Adjust volume and tone.

5. Assign the tuned frequency to one of the buttons in Bank [4] (the buttons in Bank [14] are also used in FM1) (Preset memory).

Press and hold down one of the buttons in Bank [4] (FM1: [4], [14]) for at least 2 sec-

onds. The frequency is assigned to the selected button when the preset number [27] stops flashing on the display. Up to 18 FM stations (12 for FM1 and 6 for FM2), and 6 MW/LW stations can be assigned to the preset memory buttons in Bank [4] (FM1: [4], [14]).

6. Once a frequency is assigned to a button in Bank [4] (FM1: [4], [14]), you just need to press that button to tune it in.

This also causes the number of the button pressed to appear at position [27] on the display.

Function Mode

The buttons in Bank [14] can be used as the function buttons. Since 12 stations can be preset for FM1, the function is turned on or off with button [13]. Since only 6 stations can be preset for FM2 and MW/LW, the function is automatically turned on. When the function is turned on, subsequent operations can be performed.

Manual Tuning

Use manual tuning when stations are too weak to be picked up by seek tuning.

1. Turn on "MANU" [40] by holding down button [2] in Bank [14] for 2 seconds or more.
2. Each press of the (▶) side of button [2] increases the frequency in 50 kHz steps in the FM band, 9 kHz in the MW band and 1 kHz in the LW band. Pressing the (◀) side of button [2] decreases the frequency. Holding down either side of button [2] changes the frequency at high speed.

Adjusting Seek Sensitivity

The seek tuning function of this tuner lets you select between a local setting for reception of strong stations only, and a DX (distant) setting for reception of weaker stations. The local setting also has 4 seek tuning sensitivity levels for FM and 2 levels for MW/LW to match local conditions.

Changing the Local Seek Sensitivity

1. Use button [12] to select a band.
2. Hold down button [2] in Bank [14] for more than 2 seconds, and the display will show you the current local seek sensitivity for about 5 seconds.
3. While the local seek sensitivity remains on the display, press the (▶) side of button [2] to increase the sensitivity level, and the (◀) side to decrease the level as shown below.

FM : LOC-1 = LOC-2 = LOC-3 = LOC-4
MW/LW: LOC-1 = LOC-2

The LOC-4 setting allows reception of only the strongest stations, while lower settings let you receive progressively weaker stations.

- The display of local seek sensitivity returns to the frequency when about 5 seconds have elapsed after the change of sensitivity.

Switching between Local and DX

Press button [2] in Bank [14] to switch between Local and DX (distant) seek tuning. When "LOC.S" [29] is shown on the display, seek tuning is performed with the local seek sensitivity. Otherwise, seek tuning is performed with the DX seek sensitivity.

Switching between FM Stereo and Mono

Generally, it is best to allow the ARC (Automatic Reception Control) function to automatically set the optimum listening conditions. When stereo broadcasting is received, "◐◑" [26] will appear on the display. When there is a large amount of noise, you can press button [2] in Bank [14] for clearer mono reception ("MONO" [28] will appear on the display).

BSM (Best Stations Memory)

This function automatically locates stronger stations and automatically assigns their frequencies to the buttons in Bank [4] (FM1: [4], [14]), from strongest to weakest. It comes in handy when trying to find local stations while driving.

1. Press button [12] and select a band.
 2. Holding down button [2] in Bank [14] for about 2 seconds will start BSM search. At this time, "BSM" will flash on the display.
 3. The frequency display will return once BSM search is complete, and frequencies are assigned to buttons [1] through [6] (FM1: [1] through [6] in Bank [4] (FM1: [4], [14])).
- At the end of the BSM search, the displayed frequency is that assigned to button [1] in Bank [4].
 - You can cancel BSM search by pressing button [2] in Bank [14] again.
 - If there are fewer than 6 (FM1: 12) strong stations in the area, some of the buttons in Bank [4] (FM1: [4], [14]) will not be assigned frequencies, so they will retain any frequencies assigned to them previously.

- BSM search may take as long as 30 seconds in areas where there are few strong stations.

Preset Scan Tuning

This function lets you automatically monitor the stations assigned to the preset buttons.

1. Press button [2] in Bank [14]. The frequency will appear on the display [38] and the preset number [27] will blink. Each station assigned to the buttons in Bank [4] (FM1: [4], [14]) will be automatically tuned in for about 8 seconds.
 2. When you hear a station that you like, press button [2] in Bank [14] again to cancel preset scan tuning and remain at that station.
- Stations stored in memory under the buttons [4], [14] but whose signal is weak will not be recalled.

Using the RDS Function

What is RDS?

RDS (Radio Data System) according to a CENELEC EN50067 is a system for transmitting data signals from FM broadcast transmitter along with the normal sound program. These data signals, which are imperceptible to listeners, are intended to aid radio listeners in tuning their receivers to a desired station. RDS receivers can decode these data signals for display or control purposes.

RDS digital signal includes various data, such as PI, PS, AF, TP, TA, EON and PTY.

- PI.....Program Identification Code
- PS.....Program Service Name
- AF.....List of Alternative Frequencies
- TP.....Traffic Program Identification Code (Similar to SK signal of ARI system)

TATraffic Announcement Code (Similar to DK signal of ARI system)

EONEnhanced Other Network Information Code. (In some countries, EON is not offered by broadcasters.)

PTYProgram type ID code

RDS Function of this Unit

This unit has the following functions for making use of RDS data.

- PS, the name of the currently listened station is displayed.
- AF (Alternative Frequency) function. This enables the receiver to automatically retune to more suitable frequencies transmitting the same program.
- TP/TA, EON, user selectable reception of the traffic information service, offered by RDS.
- PTY codes enable you to automatically receive stations broadcasting the same program content.

Network/Station Name Display

Switch the tuner on and choose one of the 2 FM bands.

When you tune into an RDS station with manual or seek tuning, the frequency display changes to the network/station name display after a few seconds by means of the PS code.

- The RDS functions of this unit use RDS codes transmitted along with FM broadcasts. RDS doesn't work on the MW or LW bands.
- The RDS functions may not work properly in areas where the RDS transmissions are at an experimental stage or where there are flaws in the broadcasting system.

www.DataSheet4U.com

- Hold down button ⑦ in Bank [14] for more than 2 seconds to change the network/station name display to the frequency display. The frequency will be displayed only while the button is being held down.

AF Function

This receiver retunes automatically to a more suitable transmitter, contained in the list of Alternative Frequencies (AF), to enable the motorist to keep listening to programs in the same network.

Example:

If a motorist travels as shown below, from point A to point B, (and has selected AF function) then the receiver will automatically retune to a more suitable frequency transmitting the same program. This is shown by the automatic retuning from 98.5 MHz to 107.5 MHz to 96.0 MHz to 102.5 MHz.

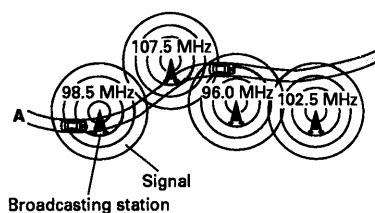

To activate the Alternative Frequency Function, press button [7], "AF" [37] will appear on the display. Once tuned to a RDS station, as long as you drive within an area served by the same network, the receiver will automatically retune to a more suitable

station transmitting the same program, by utilizing the data in the AF list.

- "PI SEEK" will appear on the display, if the AF function has been selected, and a suitable AF station cannot be found. In this case, the receiver will mute the radio sound and search the frequency band, in order to find a station with the same PI code. The receiver will return to the original frequency if the same or related PI code cannot be found.
 - The AF function will not work in the following cases:
 - when the receiver is tuned to a non-RDS station. (local station)
 - when the RDS station does not transmit any AF list data.
 - when the receiver cannot receive the AF list due to disturbances.
- When the receiver is unable to find a PI code the "AF" [37] indicator will flash on the display. Thus indicating that the AF function cannot be performed.

Preset recall

- When recalling preset stations in the AF mode, the tuner will be tuned to the stored frequency and the AF function will be operative i.e. when the signal of the recalled station is weak or has a different PI, the radio will look into the AF list and if necessary start a PI-seek in order to find a station with the same or related PI code. When the tuner is performing a PI seek "PI SEEK" is shown on the display. If the PI seek is successful, the tuner will be tuned to the new frequency that transmits the same program service (i.e. with the

same PI code) and the display will show the stored PS.

If the PI seek is not successful, the tuner will return to the stored frequency. If a new station (with a different PI code) would be received on this frequency, this station will become audible. The display will show the frequency instead of PS.

- When recalling preset stations in the AF=OFF mode, the tuner will be tuned to the stored frequency and the display will show the stored PS. In case the tuned station has a PI code that is different from the stored one, the tuner will accept the new PI code and stay tuned to the initial frequency. The display will show the new PS when the signal of the tuned station is strong enough.

Listening to Regional Stations

In some countries a particular program service may "opt out" during a certain part of the day in several regional variants at particular locations. Since these regional variants are broadcasting a different program they temporarily have a PI and a PS that is different from the main program service. The PI's are mostly "generically linked". The AF list may either be common for all regional variants or each regional variant may have its own AF list.

In other countries there may be regional stations which are not an "opt out" of a particular main program service but which have an independent existence. These regional stations all have a different PS. Their PI's may be "generically linked" and their AF lists may carry frequencies which are alternatives for that regional station only.

1) Regional OFF Mode

When AF is ON and REG is OFF, the receiver will switch automatically to strong stations that are likely to be broadcasting the same program but which do not necessarily match the region code. This is of benefit when the regional variants just carry the same program, but will become annoying if the receiver switches back and forth between different programs. In this case it is recommended to put the receiver in the REG ON mode.

2) Regional ON Mode

When AF is ON and REG is ON, the receiver switches automatically only to stations that precisely match the region code and are therefore definitely broadcasting the same program.

REG ON/OFF

To put the radio in the REG ON mode, press button [7] for more than 2 seconds. "REG" [30] will appear on the display. To cancel the REG ON mode i.e. to put the radio back in the default REG OFF mode, press button [7] again. "REG" [30] will disappear from the display.

PTY function

This unit's PTY function uses the PTY codes put out by the RDS station to provide 3 functions: PTY Display, PTY Seek and PTY Alarm.

- PTY Display is a function that shows the program type of a received station if the broadcast station is an RDS station and is putting out a PTY code.
- PTY Seek is a function that receives RDS stations broadcasting the program type that the user has selected beforehand.

- PTY Alarm is a function that receives an RDS station after picking up an emergency PTY alarm code put out by that station when a natural disaster or nuclear accident, etc., has occurred.

PTY indication switching

When an RDS station is received, the network/station name display appears. At this point, if the unit has picked up the PTY code, press button ⑦ in Bank [14] and PTY (program type) will be displayed for about 8 seconds.

- PTY display contents are of the following 16 types: NO PTY, AFFAIRS, CLASSICS, CULTURE, DRAMA, EASY MUS, EDUCATE, INFO, L. CLASS, NEWS, OTH MUS, POP MUS, ROCK MUS, SCIENCE, SPORT, VARIED
- Some stations may broadcast program contents that differ from the PTY code.
- "NO PTY" is displayed when no PTY code can be picked up from the received station.

Setting the program type

1. Press and hold down button ⑥ in Bank [14] for at least 2 seconds to switch to the PTY setting mode. ("PTY" [31] will light and the program types will be shown on the display for about 5 seconds.)
2. While the program types are shown on the display, press the (◀) side or (▶) side of button [2] to select the type that you want.

Note:

In the CURRENT mode, if the currently received station is an RDS station and the PTY code has already been picked up, then the program type is automatically set to match that station's PTY code.

PTY SEEK

For automatic reception of RDS stations having the PTY code that you have selected beforehand.

Pressing button ⑥ in Bank [14] causes your selected program type to flash on the display and PTY SEEK to begin.

("PTY" [31] flashes)

- If PTY SEEK is unsuccessful, "NO PTY" will be shown on the display for about 2 seconds, after which it will return to the station received before PTY SEEK began.
- Non TP RDS stations may be received during PTY seek even if TA (Traffic Information Standby) is on. In this case an alarm sounds about 30 seconds to tell you that it is not a TP station.
- PTY seek automatically receives RDS stations having a different PI code with the set PTY code with the set PTY code. However, it will return to the previous station if "NO PTY" is displayed.

PTY Alarm

Among the PTY codes there is also one for emergency announcements warning of natural disasters, nuclear reactor accidents, etc. In case of such disasters, RDS stations may output this emergency PTY alarm code. When this unit is ON (not during MWLW reception), and this PTY code is picked up, "ALARM" will light on the display, volume will be set to TA interrupt level, and that RDS station will be received. When the RDS station stops putting out the emergency PTY alarm code, the unit will return to the previous source. To return to the previous source during reception of the emergency program, press button [6].

Traffic Information Reception

TP and EON-TP function

When a traffic information station (TP station) is selected, "TP" [34] lights on the display, thus indicating traffic report can be received through this station. The "EON" [32] and "TP" [34] will light on the display when a selected station (this network) is broadcasting EON information which cross-references at least one program service which carries traffic information, thus indicating traffic report can be received through another program service by using the EON function of this unit. In both cases, by briefly pressing button [6], traffic report waiting status will be entered.

Traffic information reception by EON-TP

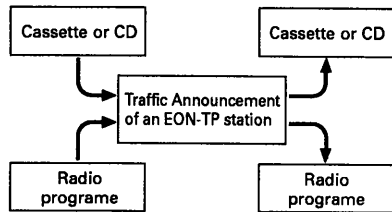

Traffic Announcement Volume Adjustment

The volume of the traffic announcement is temporarily stored in memory. The next time a report is received, the volume will be at the previous setting.

TP Alarm Function

In TA mode, about 30 seconds after "TP" [34] disappears from the display, which occurs if the signal from the TP station

becomes weak, an alarm sounds for 10 seconds to tell you to tune to another TP stations.

TA Reception during CD or Cassette Play

If the radio is already set to the FM band and tuned to a TP or EON-TP station, even when listening to the cassette or the multi-play CD player, when the button [6] is pushed ("TA" [35] is shown on the display), traffic report waiting will begin. When a traffic report begins, the system will switch from cassette or CD to the traffic report.

BSA function

While button [6] is on, ("TA" [35] is shown on the display) and AF function is off, and you are listening to either the cassette or multi-play CD player, should the TP station become weak, the radio will start BSA (Best TP Station Auto Search) 10 seconds after "TP" [34] disappears from the display. The tuner will automatically tune to the strongest TP station in the area, and will stand by for a traffic bulletin. BSA does not work when the AF function is selected, so turn the AF function off by pressing button [7] when you want to use BSA.

TP Alarm Function

In AF mode, about 30 seconds after "TP" [34] disappears from the display, which occurs if the signal from the TP station becomes weak, an alarm sounds for 10 seconds to tell you to tune to another TP station.

Tuning Functions on each RDS mode

Tuning Mode	AF Mode	TA Mode & AF plus TA Mode
Seek Tuning will stop to find,	RDS Stations	TP or EON-TP Stations
BSM will select and memorize in presets,	RDS Stations	TP Stations

Non-RDS stations such as those using the Swedish MBS system may be tuned in as RDS stations, but this is due to both systems using the same 57 kHz subcarrier frequency and is not a malfunction of the unit.

Tuning Steps

The tuning step is normally 50 kHz during seek tuning on an FM band. However this tuning step changes to 100 kHz when the set is in AF or TP mode. In some countries it may be desired to set a tuning step of 50 kHz in AF mode by holding down the button ① in Bank [4] while turning the ignition key from OFF to ON.

- During manual tuning, the step does not change; it remains fixed at 50 kHz.
- The tuning step will return to 100 kHz if the batteries supply is temporarily disconnected or the clear button is pressed.
- In AF mode, only those stations being broadcast at 100 kHz steps are subject to AF reception (CENELEC STANDARD).

Using the Tape Deck

Parts Identification

Fig. 1

- [2] Fast Forward, Rewind/Music search
- [3] Cassette door
- [5] Eject
- [10] Display
- [12] Direction change/Release
- [14] ⑦ Flex (1/f)
- [14] ⑧ Dolby B NR
- [14] ⑨ Blank Skip (B. SKIP)
- [14] ⑩ Repeat (RPT)

Fig. 4

- [41] Flex (1/f)
- [42] Blank Skip (B. SKIP)
- [43] Tape running direction indicator
- [44] Play indicator
- [45] Dolby B NR
- [46] Metal

About Cassette Tapes

- Do not use tapes longer than C-90-type (90 min.) cassettes. Longer tapes can interfere with tape transport.
- A loose or warped label on a cassette tape may interfere with the eject mechanism of the unit or cause the cassette to become jammed in the unit. Avoid using such tapes or remove such labels from the cassette before attempting use.

Storing cassettes in areas directly exposed to sunlight or high temperatures can distort them and subsequently interfere with tape transport. (Fig. 6)



Fig. 6

Store unused tapes in a tape case where there is no danger of them becoming loose or being exposed to dust.

Cleaning the Head

If the heads become dirty, the sound quality will deteriorate and there will be sound dropouts and other imperfections in performance. In this case, the head must be cleaned.

- When using a cleaning tape, play it once on one side for normal cleaning. Excessive use of the cleaning tape will increase head wear. Be sure to read the cleaning tape instructions before use.

Listening to a Tape

1. By inserting the cassette tape into slot [3], power will be turned on and the tape will begin to play.

At this time, the tape running direction indicator [43] will light up to your satisfaction.

2. Adjust volume and tone.

3. To eject the cassette tape, press the button [5].

Changing Program

When button [12] is pressed, the tape switches from side A to side B (or from side B to side A). (If the button is pressed during fast forwarding or rewinding, the current side is played.)

Dolby B NR

To hear a tape recorded using a Dolby NR system, press button ⑧ in Bank [14]. ("DOLBY" [45] appears.)

- Dolby noise reduction manufactured under license from Dolby Laboratories Licensing Corporation. "DOLBY" and the double-D symbol are trademarks of Dolby Laboratories Licensing Corporation.

Using Fast Forward and Rewind

1. To fast forward tape, press the (▶) side of button [2].

(Display shows "FF".)

To rewind tape, press the (◀) side.

(Display shows "REW".)

2. To release the fast forward or rewind function, press button [12].

www.DataSheet4U.com

Using Music Search (KEH-P720ORDS, KEH-P710ORDS)

1. To repeat the current selection (A), press the (◀) side of button [2] two consecutive times.

(Display shows "R-MS".)

To hear the following piece of music (B) rather than continue the current selection, press the (▶) side of button [2] two consecutive times.

(Display shows "F-MS".)

Pressing button [2] three consecutive times makes the normal sequence of playing resume.

2. To release the music search function, press button [12].

The following errors will cause the music search function to operate improperly, even though the unit is not malfunctioning.

- Unrecorded blank portion between selection is less than 4 seconds → the blank portion cannot be detected by the unit.
- Pauses in recorded conversations are longer than 4 seconds → the unit reads these as blanks between selections.
- Portions are recorded at very low volume for more than 4 seconds → the unit reads these as blanks between selections.

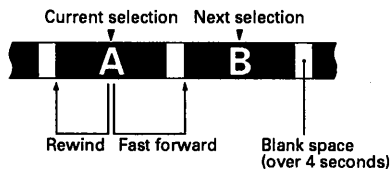

Fig. 7

Auto Tape Selector

When a cassette tape is inserted, the automatic tape selector determines the tape type, and switches between 70 μs and 120 μs equalization. When it is a metal or chrome tape, "MTL" [46] comes on. When it is a normal tape, nothing comes on.

Using the blank skip function (KEH-P720ORDS, KEH-P710ORDS)

Automatically carries out fast forward to the start of the next selection when there is a blank area of 12 seconds or more between selections.

1. Press button [9] in Bank [14] until "B. SKIP" [42] appears.
2. To release the blank skip function, press button [9] in Bank [14] again.

Using the Music Repeat Function (KEH-P720ORDS, KEH-P710ORDS)

Lets you listen to the same selection repeatedly.

1. Press button [9] in Bank [14] when you are listening to the track to be repeated until "RPT" appears on display [44].
2. To cancel the music repeat function, press button [9] in Bank [14] again or press button [12].

FLEX (Frequency Level Expander) function (KEH-P720ORDS, KEH-P710ORDS)

If the high-frequency performance is poor when playing back an old or poorly recorded cassette, you can improve it by pressing button [7] in Bank [14]. ("1/f" [41] appears.)

- This function may have little effect on a cassette offering good sound quality, for instance, one recorded from compact disc.

Using the Remote Control (KEH-P720ORDS, KEH-P710ORDS)

Loading Batteries

1. Remove the battery compartment cover from the remote controller unit.
2. Load 2 batteries, whose type is UM-4, AAA or IEC R03 1.5V, as applicable, that come with the unit into the remote controller unit, ensuring that their polarity (+/-) is correct.
3. Replace the battery compartment cover.

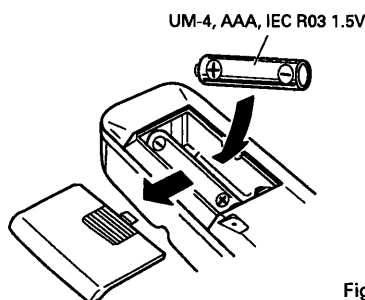

Fig. 8

Precautions When Loading Batteries

Note the following precautions when loading batteries into the remote controller unit to avoid damage due to battery fluid leakage.

- Always check carefully that you are loading batteries with the (+) and (-) poles facing in the proper directions.
- Never mix old and new batteries. Always replace batteries with two new ones.

- Some batteries may appear to be identical but have different voltage ratings. Never mix battery types.
- Some batteries can be recharged and some cannot. Be sure to carefully read the label for the batteries you use.
- To avoid damage to the remote controller caused by battery leakage, remove the batteries from the remote controller if you do not plan to use it for more than one month. If you find that fluid has leaked, thoroughly wipe out the battery compartment and load a set of new batteries.

Precautions

- Keep the remote controller unit in an area not exposed to long periods of direct sunlight.
- Hold the remote in your hand and operate it as you point it at the head unit.
- When you stop suddenly or go around a curve, the remote may fall near your feet and slide under the brake pedal, causing an extremely dangerous situation. Therefore, when not using the remote, always secure it, using the supplied Velcro tape.
- Since the transmitter employs an infrared system, it may not operate properly while car stereo unit is exposed to direct sunlight. In such a case, block the sunlight from the sensor and then perform the desired operation.
- If the remote controller fails to operate unless it is brought close to the unit, it may indicate that battery power is low. Replace the batteries in the remote controller.

Parts Identification

Fig. 2

[16] Learn Button

Takes on the same function as the button recorded with the learn function. Refer to the section "Learning Function" for details.

[18] Shift

Each press of button changes the display and the function of button [1] and [19] as follows: Volume → Fader (Balance) → Bass (Treble) → Loudness (ON/OFF) → F. I. E. mode.

Each time you press and hold down this button for 2 seconds or longer, the Source Level Adjuster mode turns ON or OFF.

[21] Volume

Press the (+) side to increase volume and the (-) side to decrease volume.

[22] Tape, Tuner

If this button is pressed to switch the tuner power on. When the cassette tape is inserted, the source changes at each press of this button:

Tape → Radio → OFF

[23] CD, M-CD

Unit goes to CD play. Press again to turn OFF.

- The function only works when this unit is connected to a separately sold Multi-Play CD player (CDX-P1210, CDX-P610).

[25] Attenuator

Press to reduce the volume to 1/10 of its current setting (The "ATT" display blinks.). Pressing again returns the volume to its original level.

- This function is available using the remote controller unit only.

Operating Radio

[17] Band

Band changes.

[19] Preset Channel

Press to tune the frequencies assigned to the preset button memory. Pressing the (▲) side tunes in the next high preset button number, while (▼) tunes in the next lower preset button number. The preset number changes at high speed when you hold either side of this button down.

[20] Seek Tuning

Press either the (◀◀) side or the (▶▶) side. When the (▶▶) side is pressed, the tuner will automatically receive high frequencies. When the (◀◀) side is pressed, it will automatically receive low frequencies.

[24] BSM

Press this button for 2 seconds or more to switch the BSM function ON and OFF.

Operating Tape

[17] Program

Press this button to change the side of tape from A to B or vice versa.

[20] Fast Forward/Rewind

Press the (▶▶) side for fast forward and the (◀◀) to rewind the tape. Press this button twice to perform the music search operation, and a third time to return to normal playback.

Operating the CD Player

- This function only works when this unit is connected to a separately sold multi-play CD player (CDX-P1210, CDX-P610).

[17] Multi-play CD player selector

Multi-play CD player changes.

- This function only works when this unit is connected to 2 or more multi-play CD players.

[19] Disc Number Search

Used to specify the number a disc loaded in the magazine. Press the (▲) side to increase the disc number on the display, and the (▼) side to reduce the disc number.

[20] Track Number Search

Press to search for a selection (track number) on the current disc. Press the (▶▶) side to increase the track number on the display, and the (◀◀) side to reduce the track number. Holding down either side of this button changes the track number at high speed.

Disc Title Input (Entering Titles)

You can enter a title for the disc in the multi-play CD player. This title stored for the disc can be displayed.

Buttons [19] and [20] on the remote controller have the same functions as buttons [1] and [2] on the head unit, respectively. (See the section "Disc Title Input".)

Learning Function

Fig.1

[13] Learn changeover button

Fig.2

[16] Learn Button

Records one button from the head unit on the remote control's learn button. This can be convenient when a button which is used often is recorded.

1. Holding down button [13] for at least 2 seconds displays "LEARN" for about 8 seconds.
 2. Press the button on the head unit that you want to use on the remote control.
 3. Press the learn button [16] on the remote controller unit. The head unit button recorded can now be used from the remote control.
- Store the button memory while "LEARN" is displayed. Once that "LEARN" display goes out, nothing can be stored into the button memory.

Using the Clock Display

Parts Identification

Fig.1

- [4] ① Hour adjustment
- [4] ② Minute adjustment
- [4] ③ Clock reset
- [8] Clock

Displaying the Time

The clock is displayed when button [8] is pressed. Press button [8] again to switch off the clock display.

- The clock display can be used only when the head unit is in operation.
- When the clock is being displayed, pressing any other button will end the clock display. The clock will be displayed again about 25 seconds after the last button is pressed.

Adjusting the Time

Adjusting Hour

While holding down button [8], press button ① in Bank [4] to adjust the hour setting. Each time button ① in Bank [4] is pressed, the hour advances by one hour. Holding down button ① in Bank [4] advances the hour at high speed.

Adjusting the Minutes

While holding down button [8], press button ② in Bank [4] to adjust the minute setting. Each time button ② in Bank [4] is pressed, the minute advances by one minute. Holding down button ② in Bank [4] advances the minute at high speed.

- After the minute is adjusted, the clock will start from 0 second when button [8] is released.

Adjust the clock with the "immediate clock adjustment"

Hold down button [8] and press button ③ in Bank [4]. The time becomes "00:00".

- If the "minute" indication is 00 to 29, it is discarded, and the clock starts. (Example: If the time is "10:18", it becomes: "10:00").
- If the "minute" indication is 30 to 59, it is rounded up, and the clock starts. (Example: If the time is "10:36", it becomes "11:00").

Playing Compact Discs

Precautions When Using the Multi-Play CD Control

- If the IP-BUS extension adapter is used, up to 4 multi play CD players can be connected. When 2 or more CD players are connected, their priorities must be specified for the Multi-play CD players. See the Multi-play CD players instructions and set the address switches correctly.
- Use this unit with optional multi-play CD players (CDX-P1210, CDX-P610).
- If 2 or more multi-play CD players are connected to the unit, you can select the CD player to be played. Each press of button [12] switches between the CD players and magazine number [47] on the display.

Parts Identification

Fig. 1

- [2] Track number search/Fast Forward, Reverse
- [4] Disc number search
- [10] Display
- [11] Source selector
- [12] Multi-play CD player select
- [13] Function ON/OFF
- [14] Disc number search
- [14] ⑦ Display selector/Edit
- [14] ⑧ Pause/Random play
- [14] ⑨ Title list/program clear
- [14] ⑩ ITS (Instant Track Selection)/ITS Play
- [14] ⑪ Scan/Compression
- [14] ⑫ Play mode switching/Manual

Fig. 5

- [36] Function indicator
- [47] Magazine number
- [48] Disc number
- [49] COMP
- [50] DBE
- [51] Magazine repeat mode
- [52] Disc repeat mode
- [53] Elapsed play time display
- [54] Track number
- [55] Manual

Using the Multi-Play CD Player

1. Press button [11] to change the display to the multi-play CD player mode and to begin disc play.

Each press of button [11] changes the mode as follows:

Tape → Radio → Multi-play CD player → OFF

2. Use the Disc Number Search function to select a disc.

Select the desired disc by pressing one of the buttons in Bank [4], [14]. The number of the disc selected appears at position [48] on the display.

- If the number at position [48] on the display does not change when you press a button in Bank [4], [14], it means that there is no disc loaded in that tray.

3. Adjust volume and tone.

4. To stop disc play, press button [11].

At another press, the normal play resumes from about where it stopped.

- After you press a button in Bank [4], [14], it may take some time before play begins due to the time necessary to load and set the disc in the mechanism.
- If the 12-disc magazine CD player CDX-P1210 is combined with this unit, button [14] acts as the disc number search button. Press button [13] to switch between the function mode and disc number search button. When used to search the disc number, turns function OFF.

Note:

- When you turn the power on or change the disc to be played, the multi-play CD player may perform a preparatory operation (verifying there is a disc, reading disc information, etc.). "READY" is displayed during this time.
- When the multi-play CD player is not working correctly, an error message appears on the display (Ex: "ERROR80"). Identify the error from the multi-play CD player owner's manual.

Track Number Search

The desired track on the disc currently being played can be selected by track (or song) number.

Make sure "MANU" [55] is not displayed on the display. If it is, hold down button ⑫ in Bank [14] more than 2 seconds.

Press the (▶) side of button [2] to increase the number at Position [54], or the (◀) side to decrease the number. Holding either side of button [2] down changes the track number at high speed.

Function Mode

If the 12-disc magazine CD player CDX-P1210 is combined with this unit, button [14] acts as the disc number search button. Press button [13] to switch between the function mode and disc number search button.

When the function is turned on, subsequent operations can be performed.

Using Fast Forward and Reverse

1. Hold down button ⑫ in Bank [14] more than 2 seconds. "MANU" [55] appears on the display.

- 2. Press the (▶) side of button [2] for fast forward, and the (◀) side for reverse.**
- Sound is output during fast forward and reverse operations.

Repeat

You can select one of the play modes (repeat modes) listed below.

Play mode (repeat mode)	Operation
One-Track Repeat	Play the current track repeatedly. <ul style="list-style-type: none"> • When you perform track number search or fast forward or rewind, the mode changes to disc repeat mode. • Switching the multi-CD player being played or the disc switches to magazine repeat mode.
Disc Repeat	Play the same disc repeatedly. <ul style="list-style-type: none"> • Switching the multi-CD player being played or the disc switching to magazine repeat mode.
Magazine Repeat	Play all discs loaded in the magazine in the multi-play CD player repeatedly. All discs in the magazine are played repeatedly from the first disc.
ALL Repeat	The mode changes to this mode when 2 or more multi-play CD players are connected. Multi-play CD players 1 to 4 are played.

Each press of button ⑫ in Bank [14] causes the mode to change as follows: One-Track Repeat ("RPT" appears on the display [53]) → Disc Repeat ("DISC" [52] appears) → Magazine Repeat ("M-CD" [51] appears) → ALL Repeat

Random Play

The microcomputer of the multi-play CD player can play tracks on discs in a random order. Random play is performed according to the current play mode (repeat mode) as follows:

Play mode (repeat mode)	Tracks to be played at random
One-Track Repeat	All tracks on the disc being played. • The play mode changes to disc repeat mode.
Disc Repeat	All tracks on the disc being played.
Magazine Repeat	All tracks on the discs in the magazine being played.
ALL Repeat*	All tracks on all discs in multi-play CD players 1 to 4.

* When 2 or more multi-play CD players are connected.

1. Select the desired random play mode (repeat mode).
2. Hold down button $\text{\textcircled{R}}$ in Bank [14] for more than 2 seconds. ("RDM" appears on the display [53].) To cancel random play, hold down button $\text{\textcircled{R}}$ in Bank [14] for more than 2 seconds again. ("RDM" disappears.)
- Since selections are played in random order, the same selection may be played twice in succession.

Using Scan

The first parts of each track are played in succession for about 10 seconds. This function is useful to search for the track or disc you want to listen to. Scan is performed according to the current play mode (repeat mode) as follows:

Play mode (repeat mode)	Tracks to be scanned and played
One-Track Repeat	All tracks on the disc being played. • The play mode changes to disc repeat mode.
Disc Repeat	All tracks on the disc being played.
Magazine Repeat	The first tracks of all the discs in the magazine being played.
ALL Repeat*	First tracks of all discs loaded in multi-play CD players 1 to 4.

* When 2 or more multi-play CD players are connected.

1. Select the desired random play mode (repeat mode).
2. Press button $\text{\textcircled{S}}$ in Bank [14]. ("SCAN" appears on the display [53].) The first parts of all tracks are played in succession for about 10 seconds.
3. When you hear the track you want, press button $\text{\textcircled{S}}$ in Bank [14] again to cancel Scan. ("SCAN" disappears.) The track (disc) being played then plays to the end.
- The previous function automatically resumes when a piece of music with which Scan began returns.

ITS (Instant Track Selection)

This function lets you program and play the tracks you want. You can listen to just your favorite tracks.

- The ADPS function* of the multi-play CD player lets you program up to 100 discs. (Up to 100 discs can be programmed including disc title inputs.)
- * ADPS: Automatic Disc Program Selection
- Up to 99 tracks can be programmed for a single disc.
- When the number of discs exceeds 100, discs not being played (information not being renewed) in memory is overwritten by the newest.
- Tracks are programmed for each disc. Programmed tracks are not erased after the disc is changed.

Programming



1. Play the track you want to program.
2. Press button $\text{\textcircled{P}}$ in Bank [14] to program the track. ("ITS" appears on the display [53] for 2 seconds.)
- Program tracks while ITS play is not in progress. It is possible during scan play or random play.

ITS Play

Tracks stored only in memory are played in order. Tracks are played according to ITS play mode (repeat mode) as follows:

Play mode (repeat mode)	Tracks to be played by ITS
One-Track Repeat	Programmed tracks on the disc being played. • The play mode changes to disc repeat mode.
Disc Repeat	Programmed tracks on the disc being played.
Magazine Repeat	Programmed track on the discs in the magazine being played. • If the disc being played contains no programmed tracks, the next disc containing programmed tracks is played.
ALL Repeat*	Programmed tracks on all discs in all magazines in multi-play CD players 1 to 4. • If the disc (multi-play CD) being played contains no programmed tracks, the next disc (multi-play CD) containing programmed tracks is played.

* When 2 or more multi-play CD players are connected.

1. Select the desired ITS play mode (repeat mode).
2. Hold down button  in Bank [14] for more than 2 seconds. ("ITS.P" appears on the display [53].) To cancel ITS play, hold down button  in Bank [14] again. ("ITS.P" disappears.)
- When you play a disc that has no tracks programmed, "EMPTY" will appear on the display [53] for about 2 seconds, indicating that ITS play is not possible.
- You can perform scan play or random play during ITS play. In this case, scan play or random play applies to all the tracks stored in memory. (If the play mode is the magazine repeat mode or all repeat mode, scan play applies to all the tracks of the discs in the magazine stored in memory.)
- During ITS play, multi-play CD players containing discs with programmed tracks are switched, and disc and track number search is performed on programmed tracks.

Erasing the ITS Program

You can erase one or all selections of the program for the disc being played by ITS.



To erase a single selection:

1. Start ITS play.
2. Play the track you wish to erase by using disc number search or track number search.
3. Hold down button  in Bank [14] for more than 2 seconds.



To erase the disc program:

1. Start normal play.
2. Play the disc you wish to erase by using disc number search.
3. Hold down button  in Bank [14] for more than 2 seconds to erase the program. ("CLEAR" appears on the display [53] for about 2 seconds.)

Pausing

1. Press button  in Bank [14] to pause during disc playback ("PAUSE" appears on display [53]).
2. Press button  in Bank [14] again to release pause.
- You can select a track using the track number search during pause. ("PAUSE" is off while a track is being searched.) When the track search ends, the found track is paused at its beginning.

Entering Titles

1. Select the disc for which you want to enter a title.
2. Hold down button  in Bank [14] for more than 2 seconds to select title input mode.
3. Press the () or () side of button [2] to select the input position. The input position moves continuously when you hold down either side of the button.

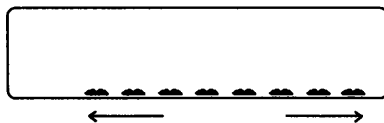



Fig. 9

4. Select characters using the (+) or (-) side of button [1]. When you hold down either side of the button, the character changes continuously. Each press of the (+) side changes the character from "A → B → C...", while each press of the (-) side changes the character from "C → B → A". To enter a space, press the space sign ().
5. Enter all characters by repeating steps 3 and 4. Press button  in Bank [14] to store them in memory. The title will appear on the display.

Disc Title List



You can list all discs loaded in the magazine being played. This function is convenient for checking discs in the magazine being played.

Each press of button  in Bank [14] displays the titles of the discs in magazine being played in ascending order of disc number.

The disc title is displayed for about 8 seconds, then the normal operation display returns.

- Nothing is displayed for discs having no titles.
- Trays with no discs are skipped.

Select the disc to be played from the disc list display.

1. Press button  in Bank [14] to display the disc title.
2. When the title of the disc you want to listen to is displayed, press button  in Bank [14]. That disc is played.

Display Switching

Each press of button  in Bank [14] switches the display [53] between the elapsed play time and disc title.

When you press button [12] while the disc title is being displayed, the normal operation display will appear for 8 seconds.

Disc Title Input

You can enter a title for the disc in the multi-play CD player. The title stored for the disc can be displayed.

- The ADPS function* of the multi-play CD player lets you enter titles for up to 100 discs. (Up to 100 discs, including ITS, can be programmed.)

*ADPS: Automatic Disc Program Selection

- A disc title can consist of up to 8 characters for a single disc.
- When the number of discs exceeds 100, discs not being played (information not being renewed) in memory is overwritten by the newest.
- One title is stored for each disc. The title stored for a disc is not erased after the disc is changed.

CD sound quality adjustment function

If you connect a Multi-play CD player with COMP (Compression) and D.B.E. (Dynamic Bass Emphasis) functions to this unit, you can use these functions with this unit. (If you connect a Multi-play CD player that does not feature these functions, even if you try to switch to these functions, "NO COMP" is displayed, indicating that switching is not possible.)

COMP (Compression) function

This function suppresses loud sounds while boosting quiet sounds to reduce the difference between the 2.

Use this function if there is distortion when you raise the volume.

When the COMP function is ON, "COMP" [49] lights in the display.



D.B.E. (Dynamic Bass Emphasis) function

When listening in a car, bass sound may be insufficient. This function boosts bass. When the D.B.E. function is ON, "DBE" [50] lights in the display.

COMP and D.B.E. switching

You can switch between 2 COMP and D.B.E. levels.

Level switching of both functions at the same time is not possible.

1. Press button  in Bank [14] for 2 or more seconds to select the switching mode.
2. Each time you press button  in Bank [14], the mode changes as follows.
COMP OFF → COMP 1 → COMP 2 → COMP OFF → DBE 1 → DBE 2 → COMP OFF
- With both COMP and D.B.E., the second mode is more effective.

● Connection Diagram



Fig. 10

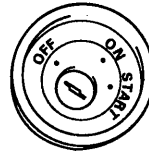

Fig. 11

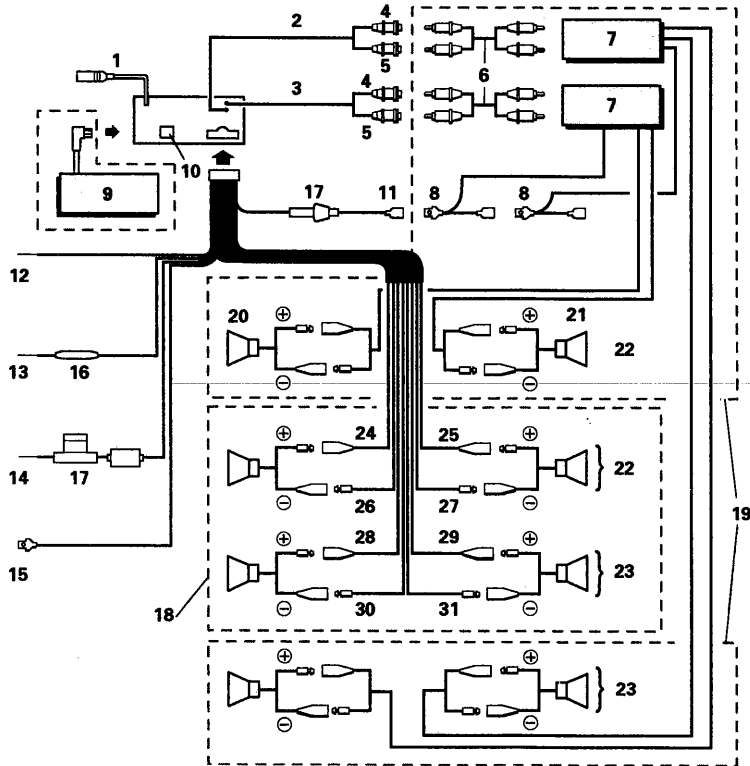

Fig. 12

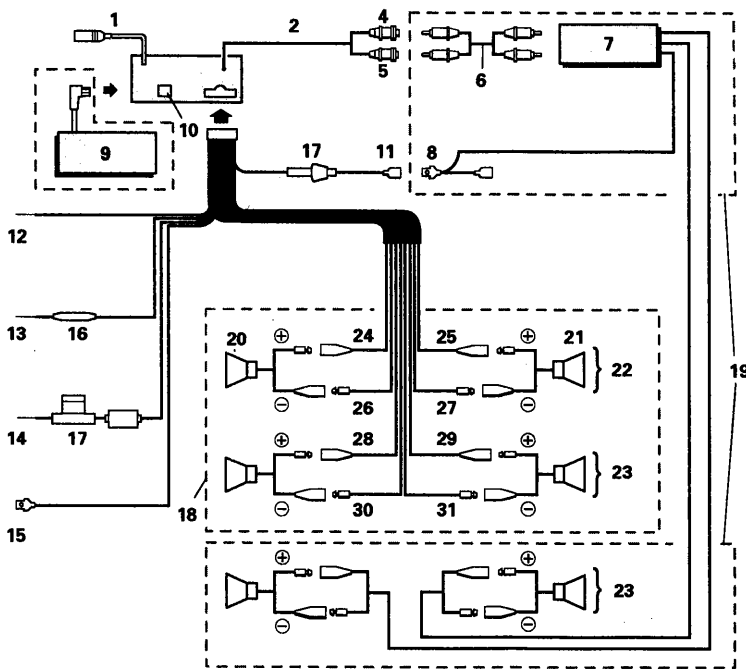

Fig. 13

www.DataSheet4U.com

Connecting the Units

Note:

- This unit is for vehicles with a 12-volt battery and negative grounding. Before installing it in a recreational vehicle, truck, or bus, check the battery voltage.
- To avoid shorts in the electrical system, be sure to disconnect the battery ⊖ cable before beginning installation.
- Refer to the owner's manual for details on connecting the various cords of the power amp and other units, then make connections correctly.
- Secure the wiring with cable clamps or adhesive tape. To protect the wiring, wrap adhesive tape around them where they lie against metal parts.
- Route and secure all wiring so it cannot touch any moving parts, such as the gear shift, handbrake, and seat rails. Do not route wiring in places that get hot, such as near the heater outlet. If the insulation of the wiring melts or gets torn, there is a danger of the wiring short-circuiting to the vehicle body.
- Don't pass the orange lead through a hole into the engine compartment to connect to the battery. This will damage the lead insulation and cause a very dangerous short.
- Do not shorten any leads. If you do, the protection circuit may fail to work when it should.
- Never feed power to other equipment by cutting the insulation of the power supply lead of the unit and tapping into the lead. The current capacity of the lead will be exceeded, causing over heating.
- When replacing fuses, be sure to use only fuses of the rating prescribed on the fuse holder.

- Since a unique BPTL circuit is employed, never wire so the speaker leads are directly grounded or the left and right speaker ⊖ leads are common.
- Speakers connected to this unit must be high-power types possessing minimum rating of 35 W and impedance of 4 to 8 ohms. Connecting speakers with output and/or impedance values other than those noted here can damage the speakers.
- When an external power amp is being used with this system, be sure not to connect the blue lead to the amp's power terminal. Likewise, do not connect the blue lead to the power terminal of the auto-antenna. Such connection could cause excessive current drain and malfunctions.
- To prevent incorrect connection, the input side of the IP-BUS connector is blue, and the output side is black. Connect the connectors of the same colors correctly.
- When the unit is mounted in a vehicle whose ignition switch does not have the ACC (accessory) position as shown in Fig. 6, be sure to connect the red lead of the unit to the terminal controlled by the ignition switch ON/OFF position. If you do not, the vehicle battery may go flat when you leave your vehicle for several hours.

ACC position (Fig. 10)

No ACC position (Fig. 11)

Connection Diagram

KEH-P720ORDS, KEH-P710ORDS (Fig. 12)

KEH-P620ORDS, KEH-P610ORDS (Fig. 13)

1. Antenna jack
2. Rear out
3. Front out
4. White
5. Red
6. Connecting cords with RCA pin plugs (sold separately)
7. Power amp (sold separately)
8. Blue
9. Multi-play CD player etc. (sold separately)
10. IP-BUS input (blue)
11. Blue
To system control terminal of the power amp or Auto-antenna relay control terminal (Max. 300 mA 12 V DC).
12. Black (ground)
To vehicle (metal) body.
13. Red
To electric terminal controlled by ignition switch (12 V DC) ON/OFF.
14. Orange
To terminal always supplied with power regardless of ignition switch position
15. Yellow/black
Cellular mute
If you use a cellular telephone, connect it via the Audio Mute lead on the cellular telephone. If not, keep the Audio Mute lead free of any connections.
16. Fuse resistor
17. Fuse holder
18. With a 2 speaker system, connect to the 2 speakers in the front or the rear.
19. Use this for connections when you have the separately available amplifier.
20. Left speaker
21. Right speaker
22. Front
23. Rear
24. Green
25. Gray
26. Green/black
27. Gray/black
28. Green/red
29. Gray/red
30. Black/green
31. Black/gray