

Pioneer *sound.vision.soul*

Service Manual

TOYOTA

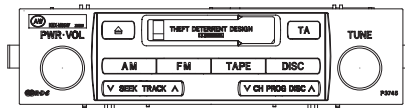

KEX-M8547ZT/EW

ORDER NO.
CRT3321

RECEIVER ASSY, RADIO

KEX-M8547ZT/EW

KEX-M8547ZT-91/EW

KEX-M8647ZT/EW

KEX-M8647ZT-91/EW

VEHICLE	DESTINATION	PRODUCED AFTER	OEM PARTS No.	ID No.	PIONEER MODEL No.
LAND CRUISER PRADO	EUROPE	August 2004	86120-60461	P3745	KEX-M8547ZT/EW
LAND CRUISER PRADO	EUROPE	August 2004	86120-60461	P3745	KEX-M8547ZT-91/EW
LAND CRUISER PRADO	EUROPE	August 2004	86120-60451	P3746	KEX-M8647ZT/EW
LAND CRUISER PRADO	EUROPE	August 2004	86120-60451	P3746	KEX-M8647ZT-91/EW

For details, refer to "Important symbols for good services".

PIONEER CORPORATION 4-1, Meguro 1-chome, Meguro-ku, Tokyo 153-8654, Japan
PIONEER ELECTRONICS (USA) INC. P.O. Box 1760, Long Beach, CA 90801-1760, U.S.A.
PIONEER EUROPE NV Haven 1087, Keetberglaan 1, 9120 Melsele, Belgium
PIONEER ELECTRONICS ASIACENTRE PTE. LTD. 253 Alexandra Road, #04-01, Singapore 159936
 ©PIONEER CORPORATION 2004

K-ZZA. JULY 2004 printed in Japan

This service manual should be used together with the following manual(s):

Model No.	Order No.	Mech.Module	Remarks
CX-1011	CRT2406	3L	Cassette Mech. Module : Mech. Description, Disassembly

Dolby noise reduction manufactured under license from Dolby Laboratories Licensing Corporation.
"Dolby" and the double-D symbol are trademarks of Dolby Laboratories Licensing Corporation.

This service manual does not describe the CD test mode.

For the operations in the CD test mode, refer to the CD player's service manual.

● Supplementary model is identical to the original except for the addition of following items.

* : Non spare part

Description	KEX-M8547ZT-91/EW KEX-M8647ZT-91/EW
Polyethylene Bag	CEG1026
Cover	CEG1045(x2)
Carton	CHG4857
Contain Box	CHL4857(x1/4)
* Air Cap	CHW1947

SAFETY INFORMATION

This service manual is intended for qualified service technicians; it is not meant for the casual do-it-yourselfer. Qualified technicians have the necessary test equipment and tools, and have been trained to properly and safely repair complex products such as those covered by this manual. Improperly performed repairs can adversely affect the safety and reliability of the product and may void the warranty. If you are not qualified to perform the repair of this product properly and safely, you should not risk trying to do so and refer the repair to a qualified service technician.

● Service Precaution

1. You should conform to the regulations governing the product (safety, radio and noise, and other regulations), and should keep the safety during servicing by following the safety instructions described in this manual.
2. When you exchange the CN473 (mentioned P.6 PART No.11) for new part. Cut all terminals about 0.5mm to 1mm. (There is some possibility to touch the terminal with under chassis because of long terminals.)

[Important symbols for good services]

In this manual, the symbols shown below indicate that adjustments, settings or cleaning should be made securely. When you find the procedures bearing any of the symbols, be sure to fulfill them:

1. Product safety



You should conform to the regulations governing the product (safety, radio and noise, and other regulations), and should keep the safety during servicing by following the safety instructions described in this manual.

2. Adjustments



To keep the original performances of the product, optimum adjustments or specification confirmation is indispensable. In accordance with the procedures or instructions described in this manual, adjustments should be performed.

3. Cleaning



For optical pickups, tape-deck heads, lenses and mirrors used in projection monitors, and other parts requiring cleaning, proper cleaning should be performed to restore their performances.

4. Shipping mode and shipping screws



To protect the product from damages or failures that may be caused during transit, the shipping mode should be set or the shipping screws should be installed before shipping out in accordance with this manual, if necessary.

5. Lubricants, glues, and replacement parts



Appropriately applying grease or glue can maintain the product performances. But improper lubrication or applying glue may lead to failures or troubles in the product. By following the instructions in this manual, be sure to apply the prescribed grease or glue to proper portions by the appropriate amount. For replacement parts or tools, the prescribed ones should be used.

CONTENTS

	SAFETY INFORMATION.....	3
	1. SPECIFICATIONS.....	5
A	2. EXPLODED VIEWS AND PARTS LIST.....	6
	2.1 EXTERIOR.....	6
	2.2 CASSETTE MECHANISM MODULE.....	8
	3. BLOCK DIAGRAM AND SCHEMATIC DIAGRAM.....	10
	3.1 BLOCK DIAGRAM.....	10
	3.2 OVERALL CONNECTION DIAGRAM(GUIDE PAGE).....	12
	3.3 KEYBOARD UNIT.....	18
	3.4 CASSETTE MECHANISM MODULE.....	20
	4. PCB CONNECTION DIAGRAM.....	22
	4.1 MAIN UNIT.....	22
	4.2 KEYBOARD UNIT(KEX-M8547ZT/EW).....	26
B	4.3 KEYBOARD UNIT(KEX-M8647ZT/EW).....	27
	4.4 CASSETTE MECHANISM MODULE.....	28
	5. ELECTRICAL PARTS LIST.....	30
	6. ADJUSTMENT.....	38
	6.1 JIG CONNECTION DIAGRAM.....	38
	6.2 CASSETTE AND AUDIO ADJUSTMENT.....	39
	6.3 SELF-DIAGNOSIS FUNCTION.....	41
	7. GENERAL INFORMATION.....	45
	7.1 DIAGNOSIS.....	45
	7.1.1 DISASSEMBLY.....	45
	7.1.2 CONNECTOR FUNCTION DESCRIPTION.....	46
	7.1.3 TROUBLE-SHOOTING.....	47
	7.2 IC.....	48
C	7.3 EXPLANATION.....	51
	7.3.1 SYSTEM BLOCK DIAGRAM.....	51
	7.3.2 OPERATIONAL FLOW CHART.....	52
	7.4 CLEANING.....	53
	8. OPERATIONS.....	54

1. SPECIFICATIONS

General

Power source 13.2V(10.5V - 16.0V allowable)
 Backup current. Less than 0.3 mA
 Grounding system Negative type
 Weight 1.18 kg

Tape player

Tape Compact cassette tape (C-30 - C-90)
 Tape speed . . . 4.76 cm/sec.(+0.14 cm/sec.,-0.05 cm/sec.)
 Wow & flutter. Less than 0.2 %(WRMS)
 Fast forward/rewind time. . . . Less than 120 sec. for C-60
 Stereo separation More than 30 dB
 Signal-to-noise ratio More than 40 dB

FM tuner

Frequency range. 87.5 - 108.0 MHz
 Usable sensitivity Less than 14 dB μ V (S/N: 30 dB)
 Signal-to-noise ratio More than 46 dB(54dB μ input)
 Distortion Less than 1.5%
 Digital noise Less than 25 mVp-p (74 dB μ input)

MW tuner

Frequency range. 522 - 1,611 kHz
 Usable sensitivity Less than 34 dB μ V(S / N : 20 dB)
 Selectivity More than 20 dB (\pm 9 kHz)
 Signal-to-noise ratio More than 42 dB (74 dB μ input)
 Distortion Less than 1.5%

LW tuner

Frequency range. 153 - 279 kHz
 Usable sensitivity Less than 40 dB μ V(S / N : 20 dB)
 Selectivity More than 20 dB (\pm 9 kHz)
 Signal-to-noise ratio More than 42 dB (74 dB μ input)
 Distortion Less than 1.5%

2. EXPLODED VIEWS AND PARTS LIST

NOTES : • Parts marked by "*" are generally unavailable because they are not in our Master Spare Parts List.

• Screw adjacent to ▽mark on the product are used for disassembly.

• For the applying amount of lubricants or glue, follow the instructions in this manual.

(In the case of no amount instructions, apply as you think it appropriate.)

2.1 EXTERIOR

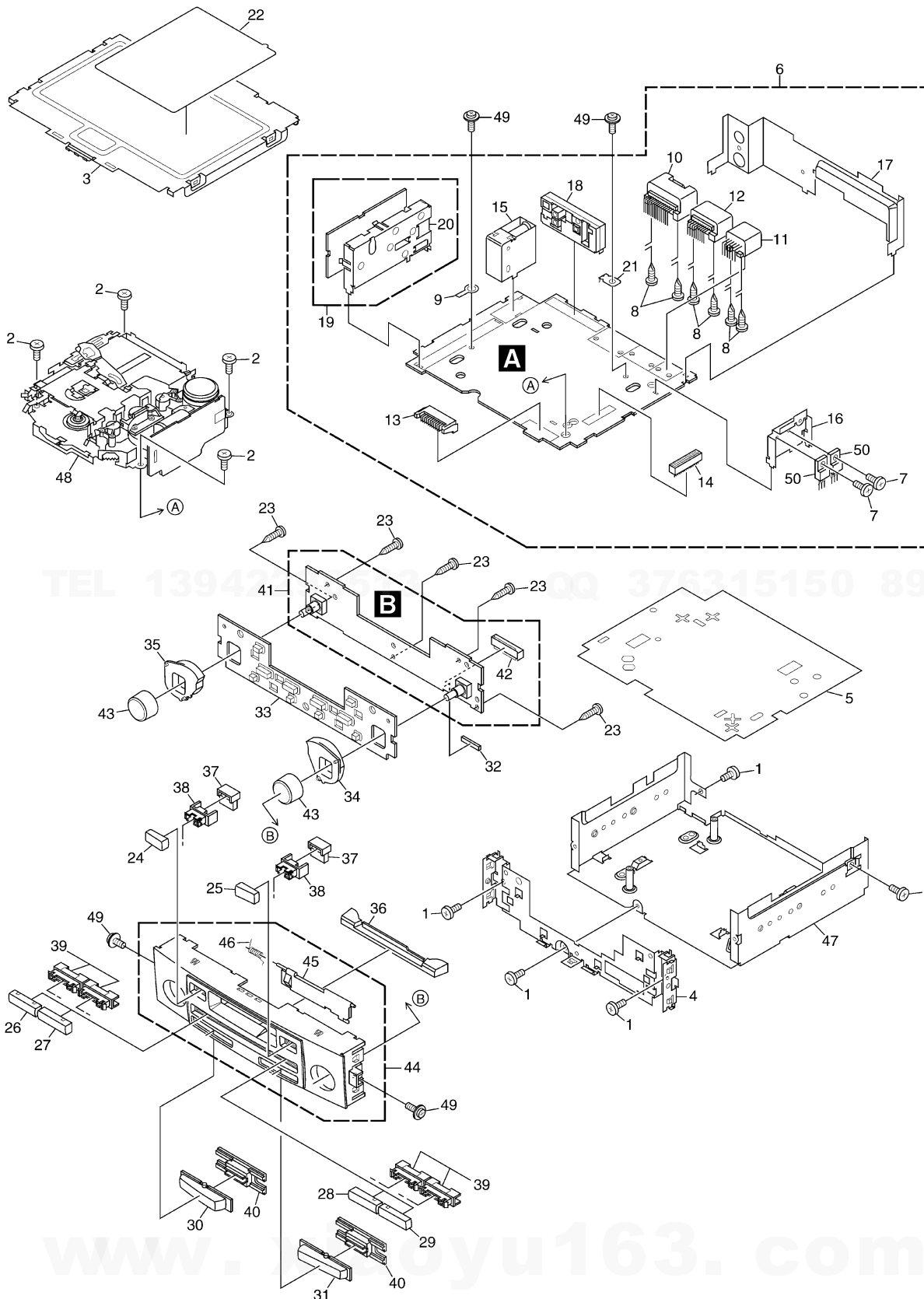

(1) EXTERIOR SECTION PARTS LIST

Mark No.	Description	Part No.	Mark No.	Description	Part No.
1	Screw	BMZ30P050FTC	26	Button	See Contrast table(2)
2	Screw	BSZ26P060FTC	27	Button	See Contrast table(2)
3	Upper Case	CNB3080	28	Button	See Contrast table(2)
4	Front Frame	CNC9684	29	Button	See Contrast table(2)
5	Insulator	CNM7528	30	Button	See Contrast table(2)
6	Main Unit	See Contrast table(2)	31	Button	See Contrast table(2)
7	Screw	BMZ30P060FTC	32	Cushion	CNM9194
8	Screw(M3x6)	CBA1393	33	Rubber	CNV6939
9	Terminal(CN502)	CKF1064	34	Lighting Conductor	CNV6942
10	Connector(CN801)	CKM1322	35	Lighting Conductor	CNV6943
11	Connector(CN473) *1	CKM1350	36	Lighting Conductor	CNV6944
12	Connector(CN472)	CKM1351	37	Lighting Conductor	CNV6948
13	Plug(CN804)	CKS3539	38	Holder	CNV6951
14	Connector(CN353)	CKS3568	39	Holder	CNV6952
15	Antenna Jack(CN501)	CKX1024	40	Holder	CNV6953
16	Holder	CNC9686	41	Keyboard Unit	See Contrast table(2)
17	Rear Frame	CND2155	42	Socket(CN901)	CKS3552
18	FM Tuner Unit	CWE1679	43	Knob Unit(TUNE)(PWR, VOL)	CXB7979
19	FM/AM Tuner Unit	CWE1773	44	Grille Unit	See Contrast table(2)
20	Holder	CNC8855	45	Door	CAT2293
21	Terminal(CN802)	VNF1084	46	Spring	CBH1371
22	Shield Unit	CXB9781	47	Chassis Unit	CXC3861
23	Screw	BPZ20P080FTC	48	Cassette Mechanism Module	EXK4290
24	Button	See Contrast table(2)	49	Screw	ISS26P055FTC
25	Button	See Contrast table(2)	50	Transistor(Q810, 811)	2SB1185

(2) CONTRAST TABLE

KEX-M8547ZT/EW and KEX-M8647ZT/EW are constructed the same except for the following:

Mark	No.	Description	KEX-M8547ZT/EW	KEX-M8647ZT/EW
	6	Main Unit	CWM9554	CWM9555
	24	Button	CAC7276(TA)	CAC7277(CS-EJECT)
	25	Button	CAC7278(CS-EJECT)	CAC7279(TA)
	26	Button	CAC7280(DISC)	CAC7268(AM)
	27	Button	CAC7281(TAPE)	CAC7269(FM)
	28	Button	CAC7282(FM)	CAC7270(TAPE)
	29	Button	CAC7283(AM)	CAC7271(DISC)
	30	Button	CAC7284(CH, PROG, DISC)	CAC7272(SEEK, TRACK)
	31	Button	CAC7285(SEEK, TRACK)	CAC7273(CH, PROG, DISC)
	41	Keyboard Unit	CWS1338	CWS1339
	44	Grille Unit	CXC3340	CXC3341

*1 : The cautions in the case of exchanging parts (mentioned P.7 PART No.11) are indicated to P.3.

2.2 CASSETTE MECHANISM MODULE

 For grease application, refer to the service manual for CX-1011 (CRT2406).

A
B
C
D
E
F

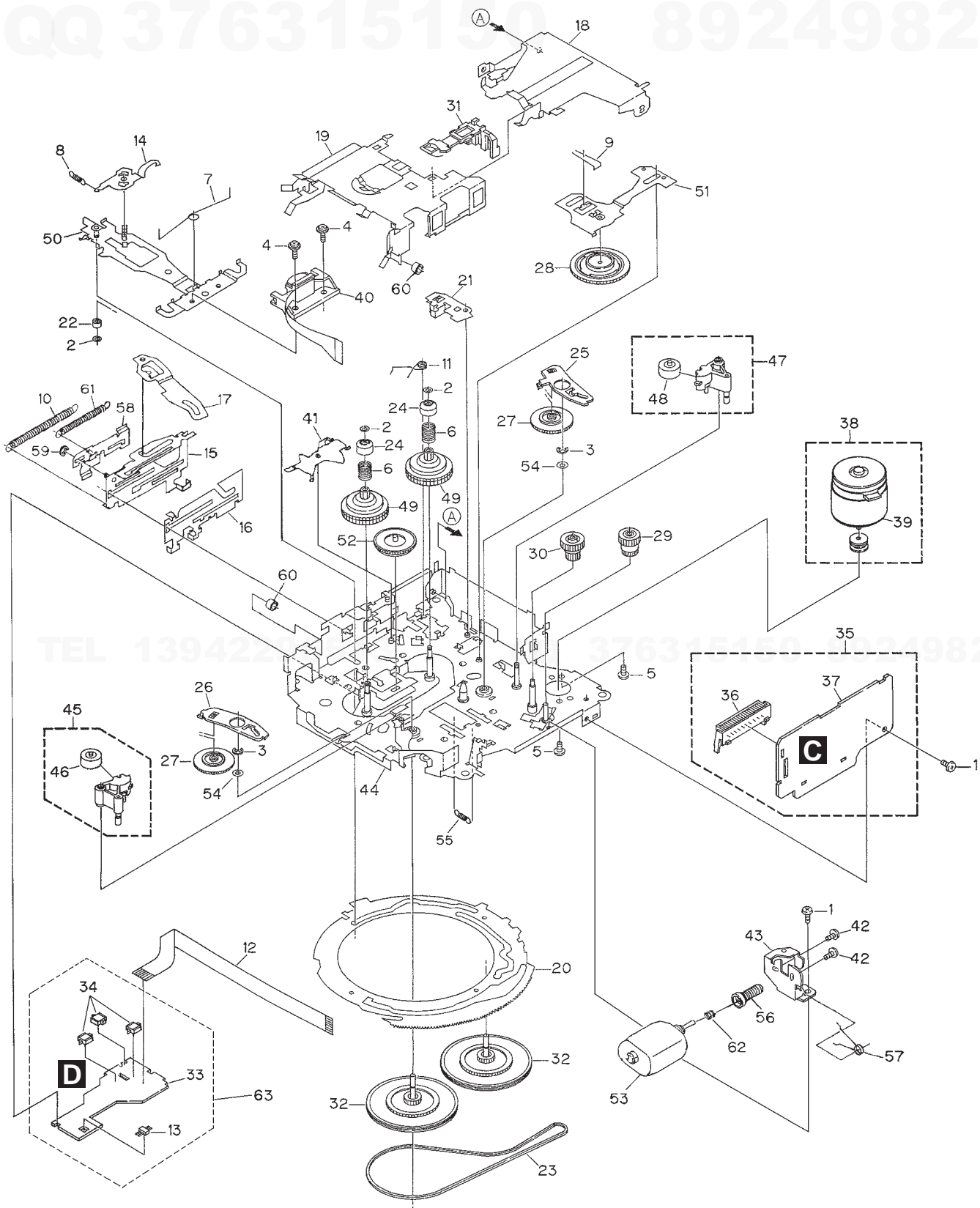

CASSETTE MECHANISM MODULE SECTION PARTS LIST

Mark No.	Description	Part No.	Mark No.	Description	Part No.
1	Screw	BSZ20P040FTC	50	Head Base Unit	EXA1611
2	Washer	CBF1037	51	Lever Unit	EXA1587
3	Washer	CBG1003	52	Gear Unit	EXA1596
4	Screw	EBA1028	53	Motor Unit(M2)	EXA1660
5	Screw	BMZ20P022FTC	54	Washer	HBF-179
6	Spring	EBH1653	55	Spring	EBH1537
7	Spring	EBH1642	56	Worm Gear	ENV1564
8	Spring	EBH1641	57	Spring	EBH1672
9	Spring	EBH1626	58	Lever	ENC1548
10	Spring	EBH1627	59	Washer	YE15FTC
11	Spring	EBH1648	60	Tube	ENM1039
12	Cord	EDD1024	61	Spring	EBH1645
13	Photo-reflector(Q101)	EGN1004	62	Spring	EBH1545
14	Arm	ENC1526	63	Sensor Unit	EWM1041
15	Lever Unit	EXA1610			
16	Lever	ENC1543			
17	Arm	ENC1532			
18	Frame	ENC1533			
19	Holder	ENC1547			
20	Gear	ENC1535			
21	Arm	ENC1550			
22	Roller	ENR1040			
23	Belt	ENT1027			
24	Collar	ENV1508			
25	Arm	ENV1539			
26	Arm	ENV1540			
27	Gear	ENV1569			
28	Gear	ENV1547			
29	Gear	ENR1044			
30	Worm Wheel	ENV1559			
31	Lever	ENV1551			
32	Flywheel	ENV1607			
33	Gathering PCB	ENX1073			
34	Switch(S101,S102,S103)	ESG1007			
35	Deck Unit	EWM1031			
36	Plug(CN251)	CKS3540			
37	Gathering PCB	ENX1066			
38	Motor Unit(M1)	EXA1618			
39	Motor	EXM1035			
40	Head Assy(HD1)	EXA1594			
41	Arm	ENC1537			
42	Screw	EBA1031			
43	Bracket	ENC1559			
44	Chassis Unit	EXA1636			
45	Pinch Holder Unit	EXA1608			
46	Pinch Roller	ENV1518			
47	Pinch Holder Unit	EXA1607			
48	Pinch Roller	ENV1518			
49	Reel Unit	EXA1625			

3. BLOCK DIAGRAM AND SCHEMATIC DIAGRAM

3.1 BLOCK DIAGRAM

A
B
C
D
E
F

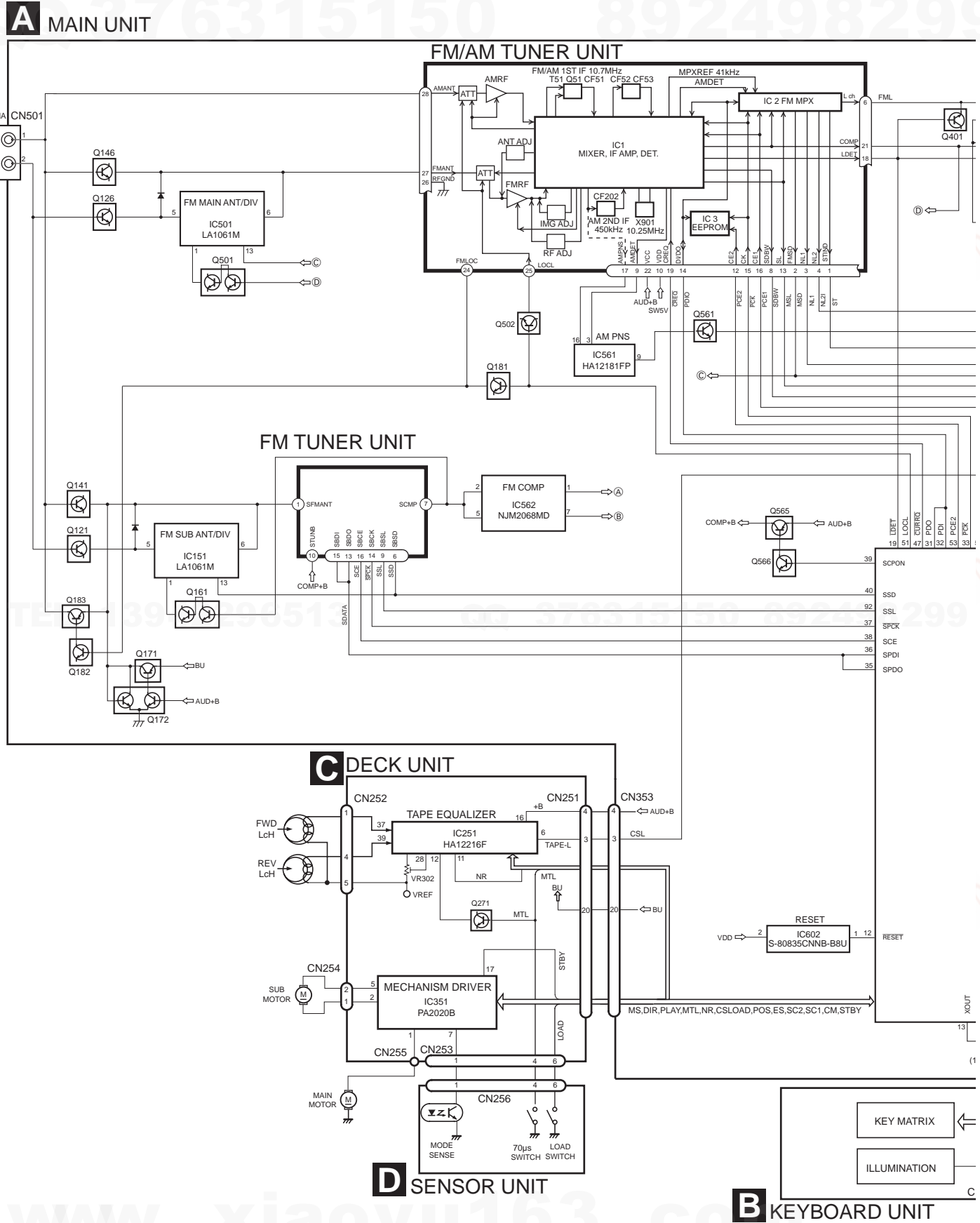

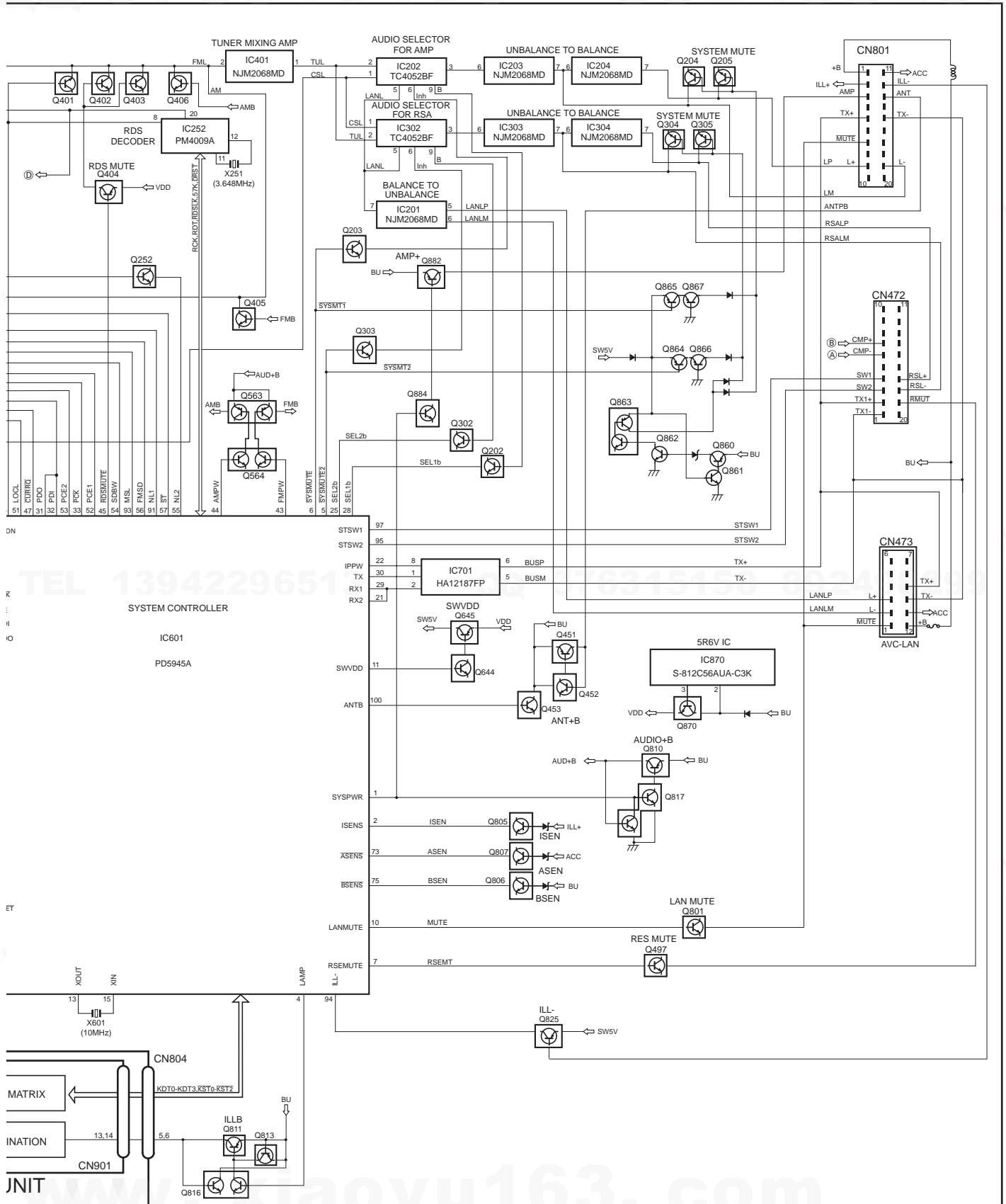

3.2 OVERALL CONNECTION DIAGRAM(GUIDE PAGE)

Note: When ordering service parts, be sure to refer to " EXPLODED VIEWS AND PARTS LIST" or "ELECTRICAL PARTS LIST".

A
B
C
D
E
F

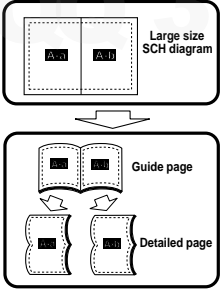

A-a

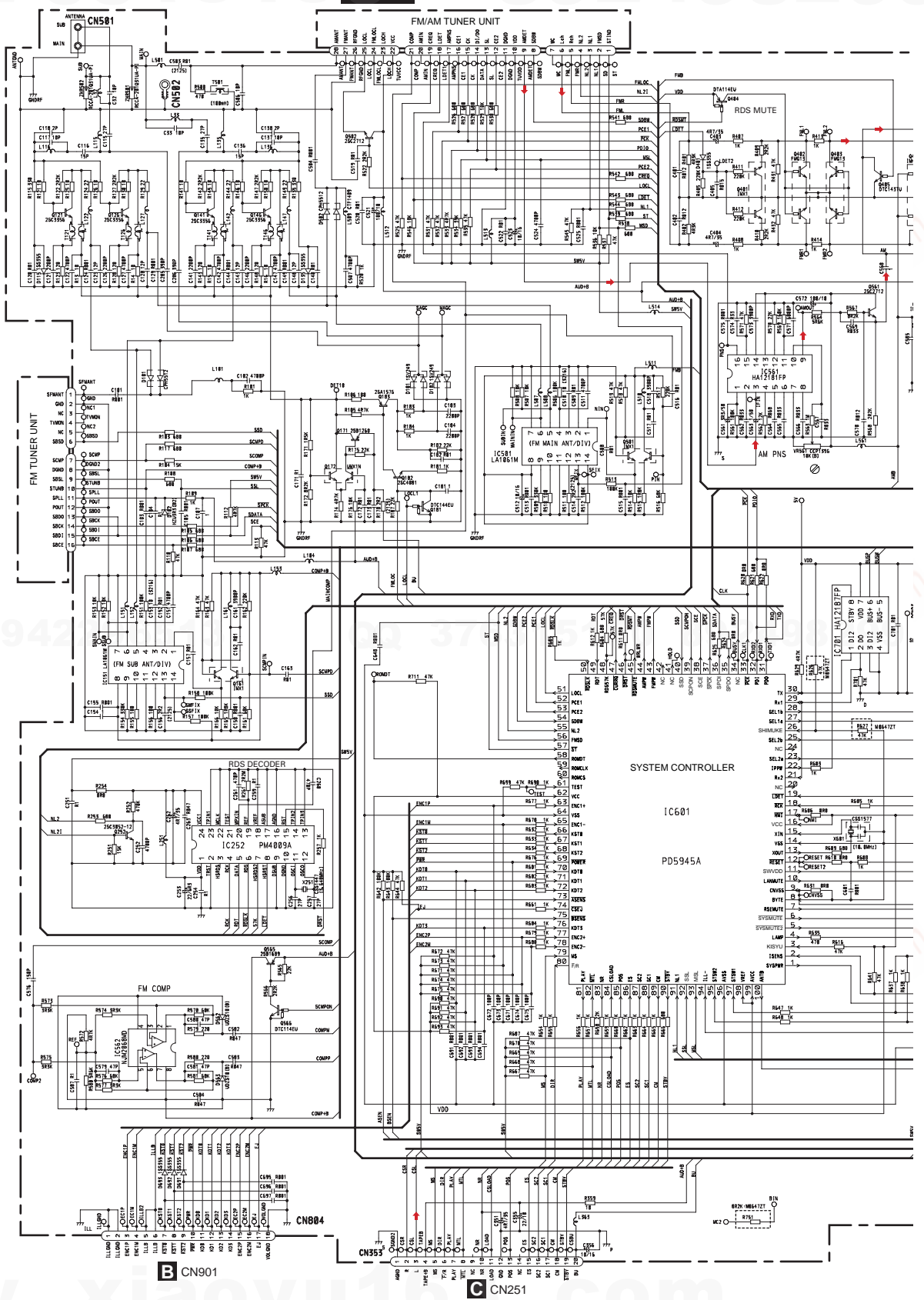

A

QQ:376315150 A-2498299

A-b

A B C D E F

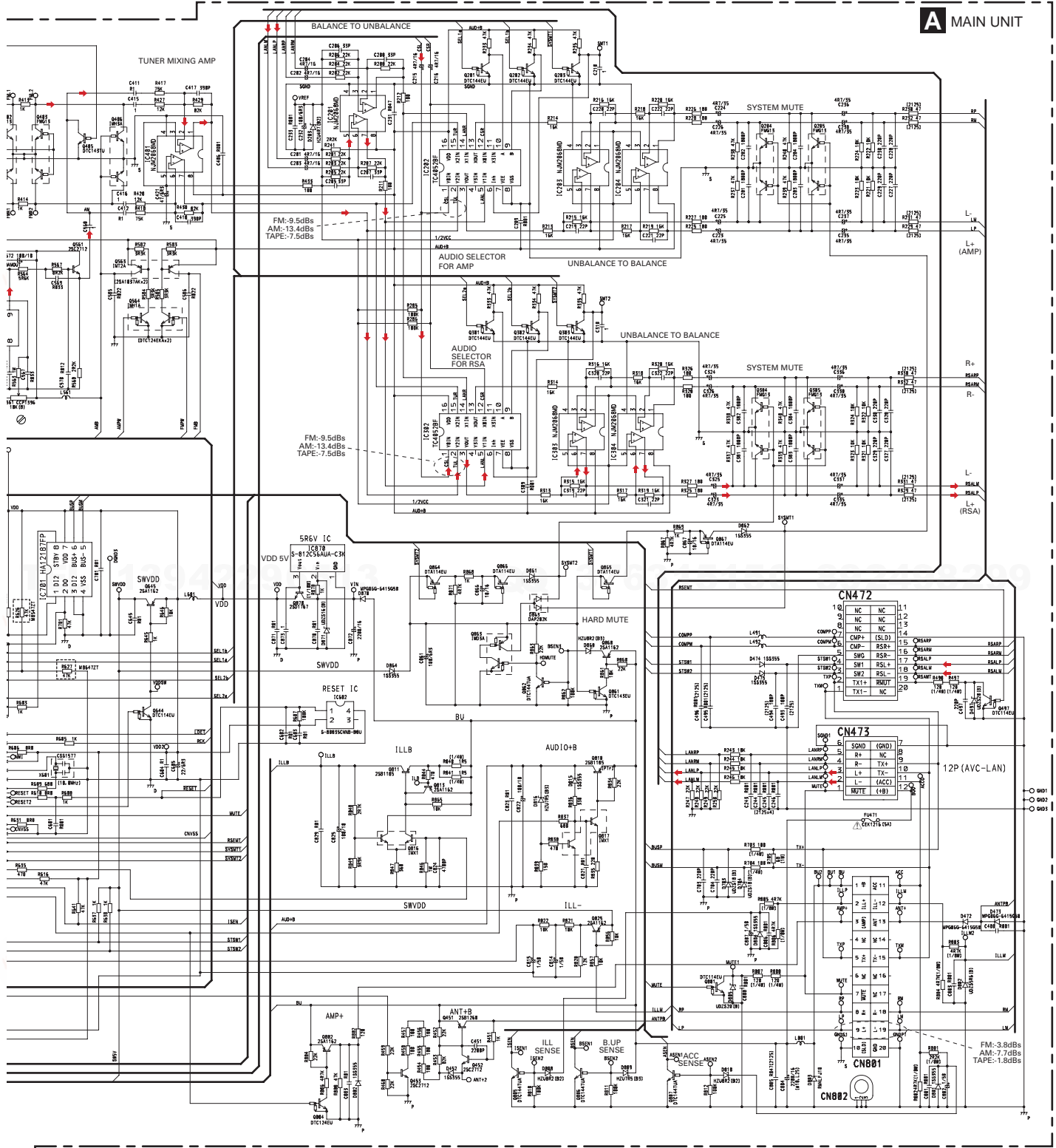

NOTE:

- Symbol indicates a resistor. No differentiation is made between chip resistors and discrete resistors.
- ⊢ Symbol indicates a capacitor. No differentiation is made between chip capacitors and discrete capacitors.

Decimal points for resistor and capacitor fixed values are expressed as:
 2.2 → 2R2
 0.022 → R022

The Δ mark found on some component parts indicates the importance of the safety factor of the part. Therefore, when replacing, be sure to use parts of identical designation.

KEX-M8547ZT/EW



1

2

4

A

A-b

B

C

D

E

F

A-a

A-a

1

2

3

4

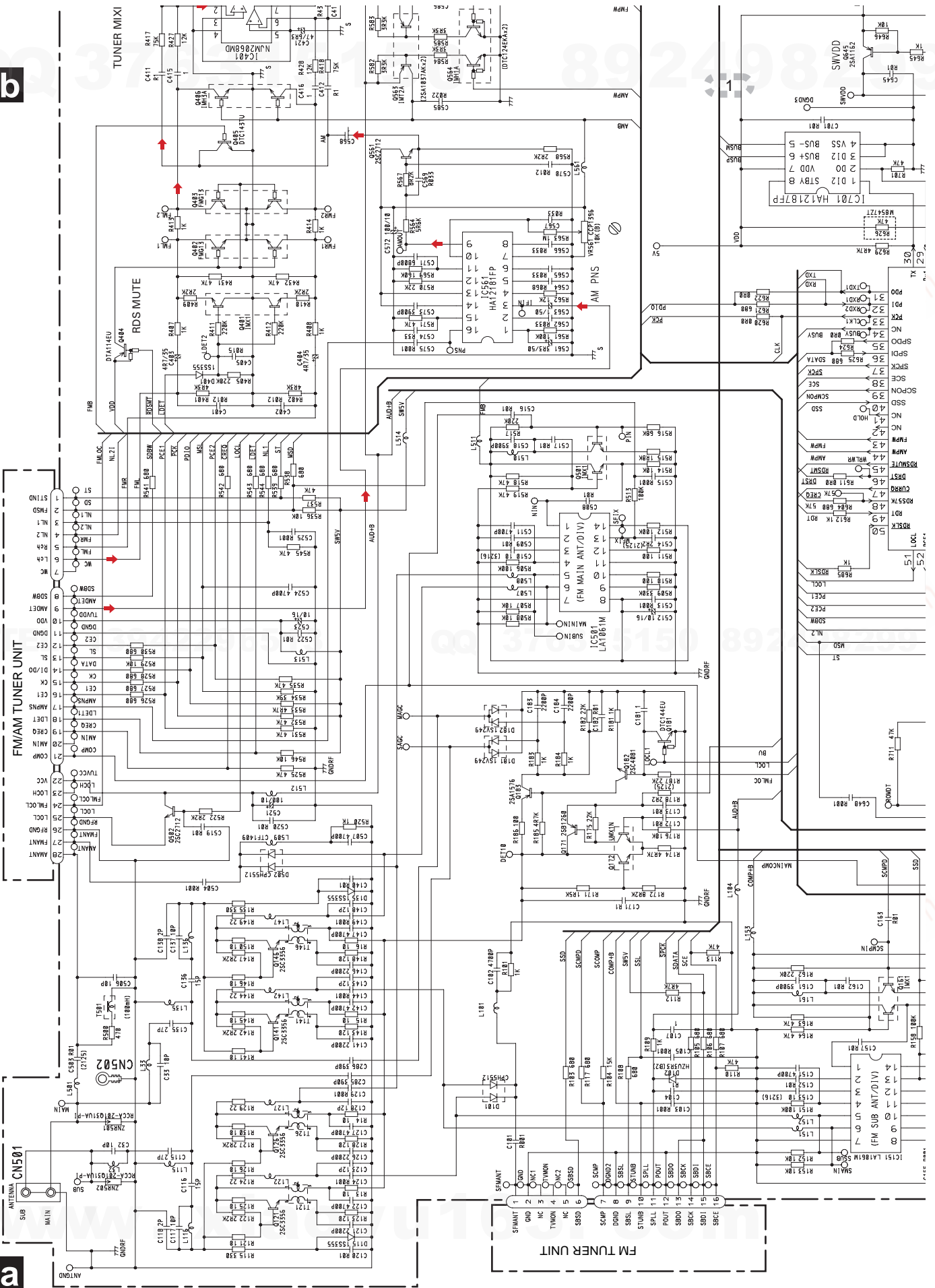

1

2

3

4

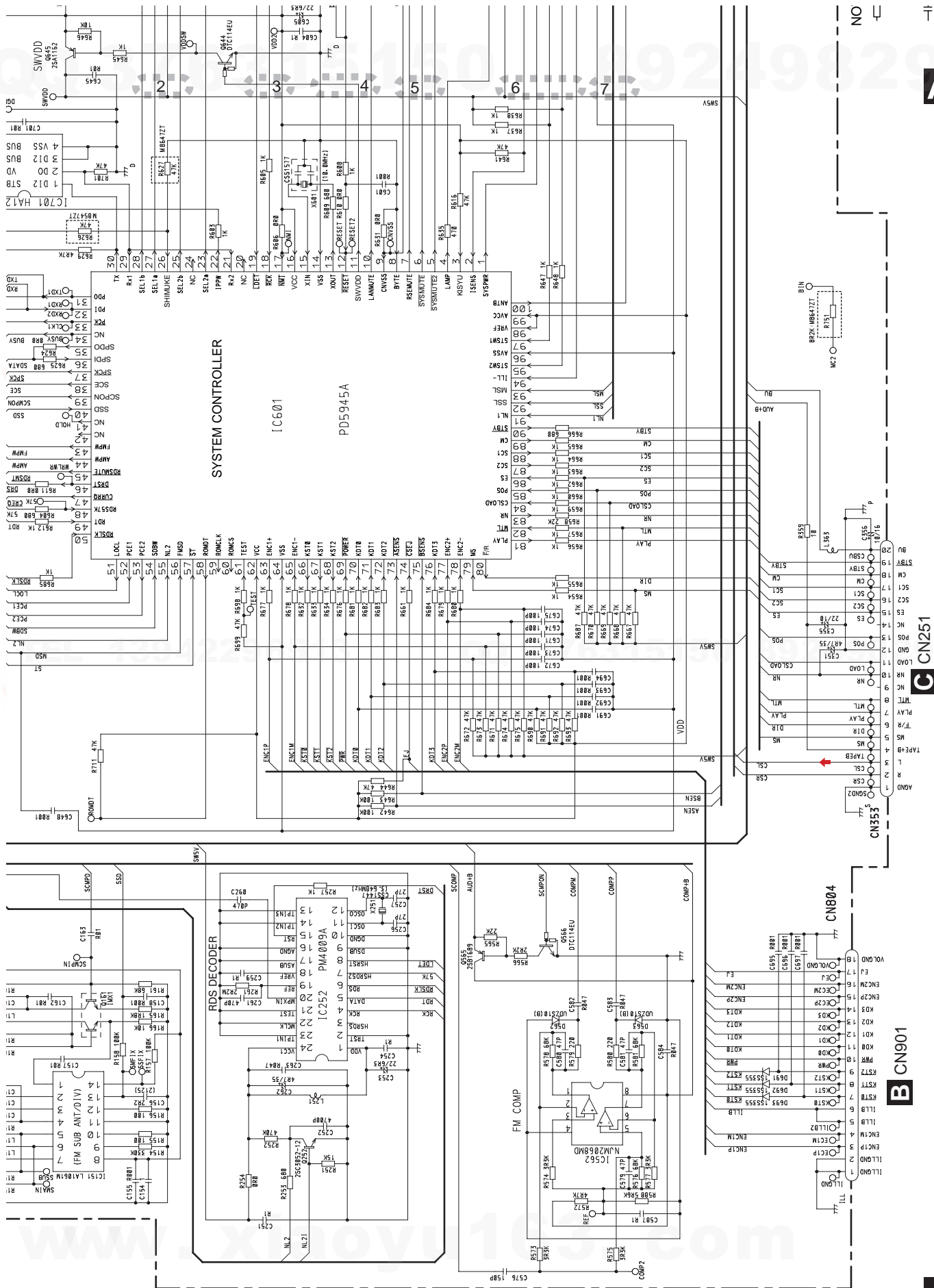

A-b

A-a

C

D

B

A-a

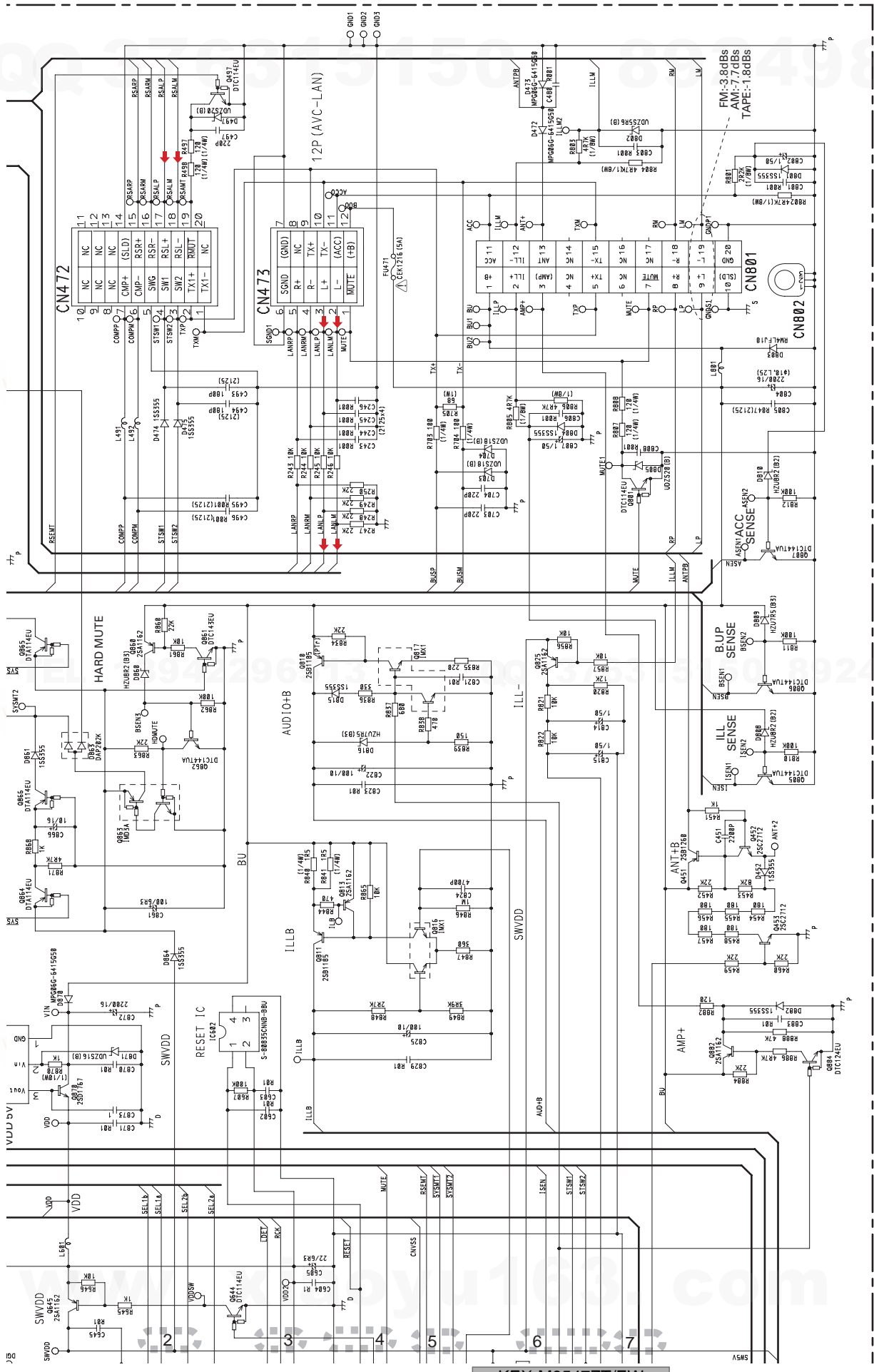

KEX-M8547ZT/EW

NOTE:

- Symbol indicates a resistor.
- No differentiation is made between chip resistors and discrete resistors.
- |— Symbol indicates a capacitor.
- No differentiation is made between chip capacitors and discrete capacitors.

Decimal points for resistor and capacitor fixed values are expressed as:
 2.2 → 2R2
 0.022 → R022

The Δ mark found on some component parts indicates the importance of the safety factor of the part. Therefore, when replacing, be sure to use parts of identical designation.

A-b

A-a

A B C D E F

3.3 KEYBOARD UNIT

QQ 376315150 892498299

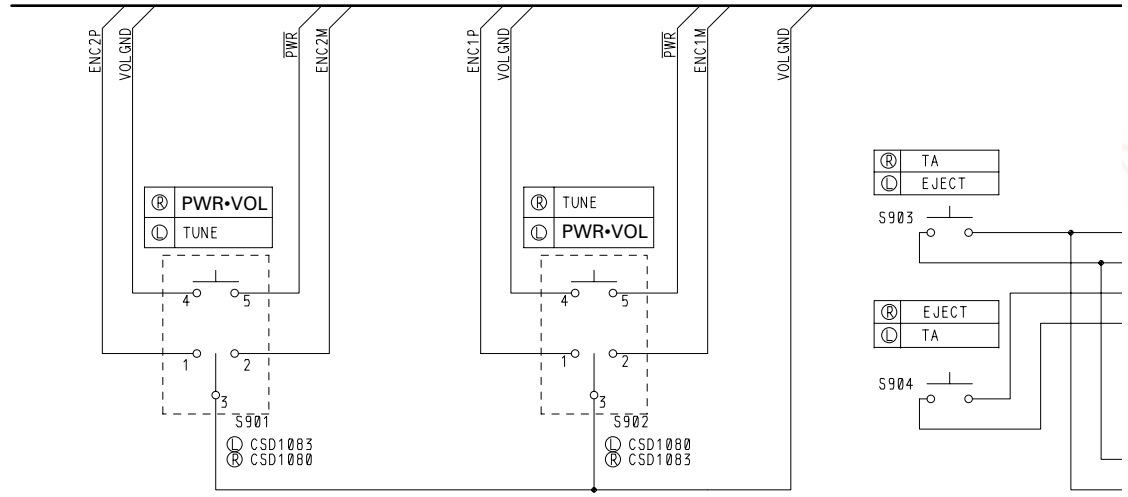

Ⓡ:KEX-M8647ZT/EW
 Ⓛ:KEX-M8547ZT/EW

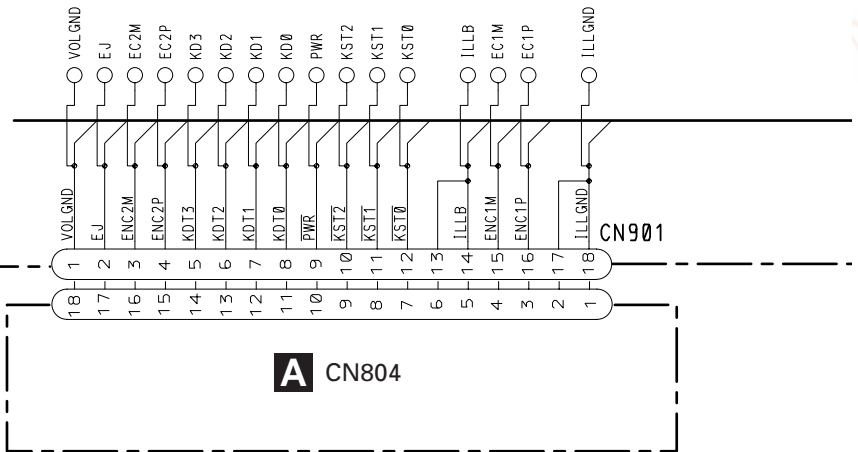

A CN804

www.xiaoyu163.com

QQ 376315150 892498299

B KEYBOARD UNIT

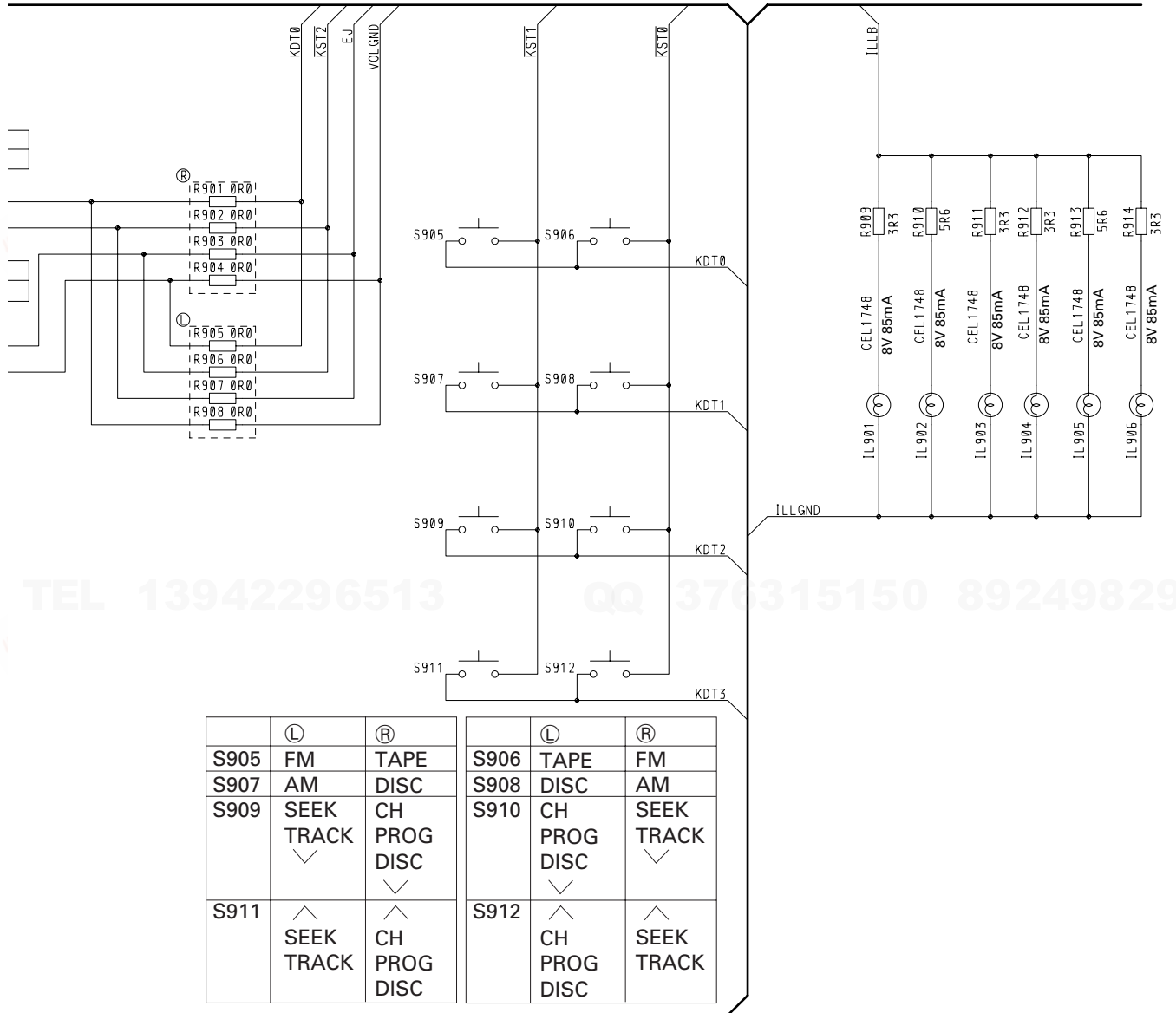

TEL 13942296513 QQ 376315150 892498299

TEL 13942296513 QQ 376315150 892498299

A B C D E

www.xiaoyu163.com

B

3.4 CASSETTE MECHANISM MODULE

C DECK UNIT

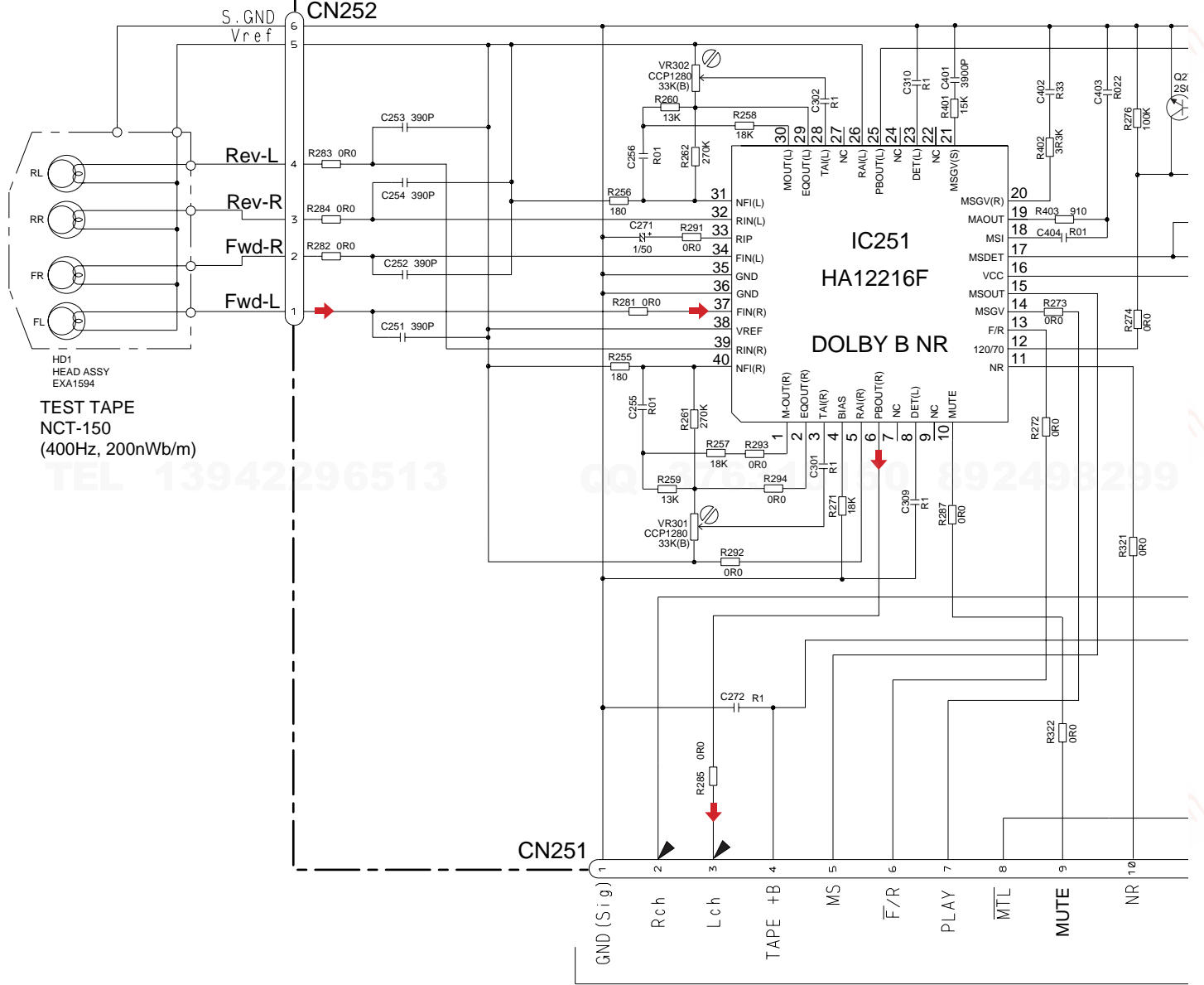

-8.24dBs(300mV)-1dB

A CN353

QQ 376315150 892498299

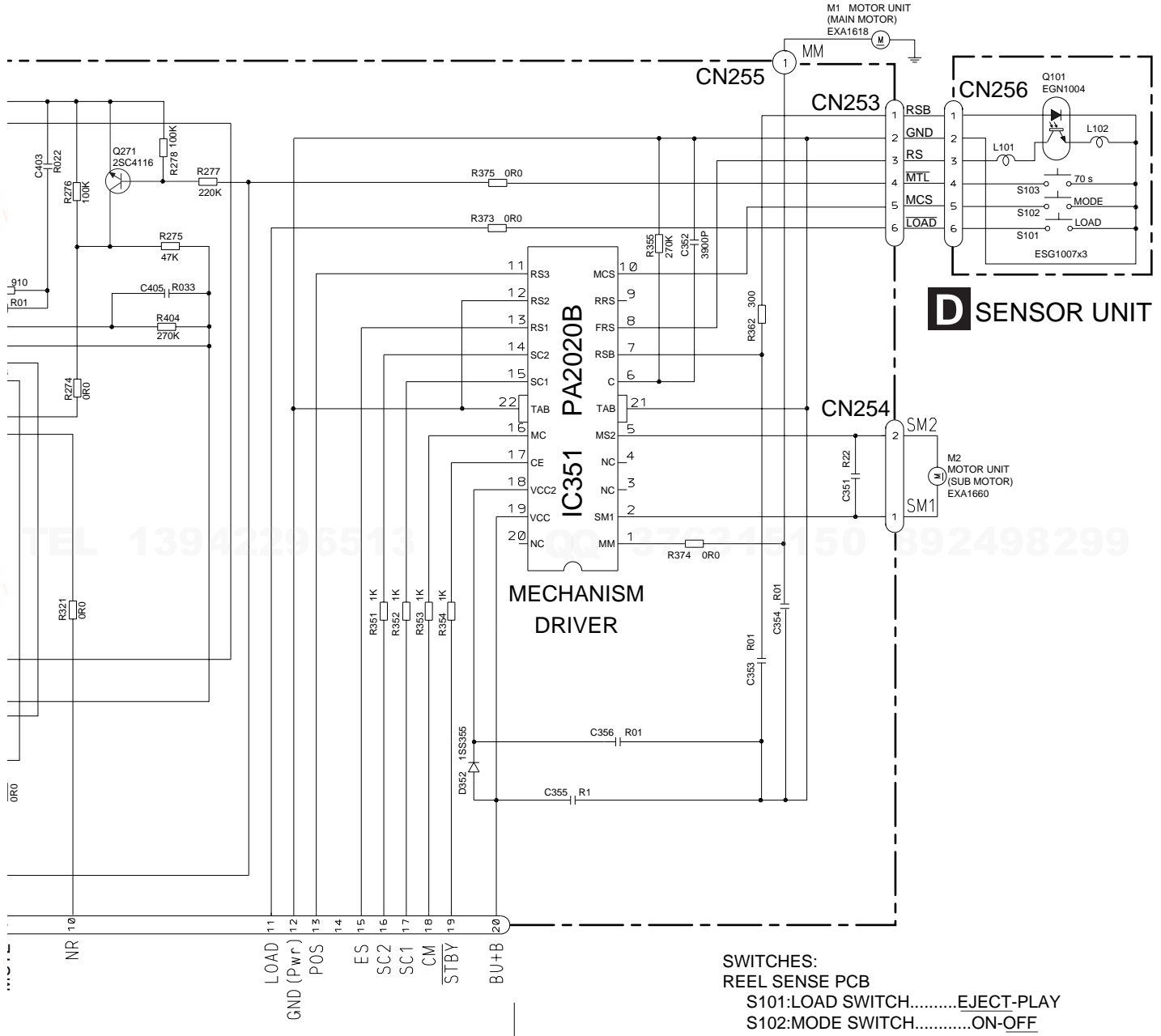

:N353

www.xiaoyu163.com

A MAIN UNIT

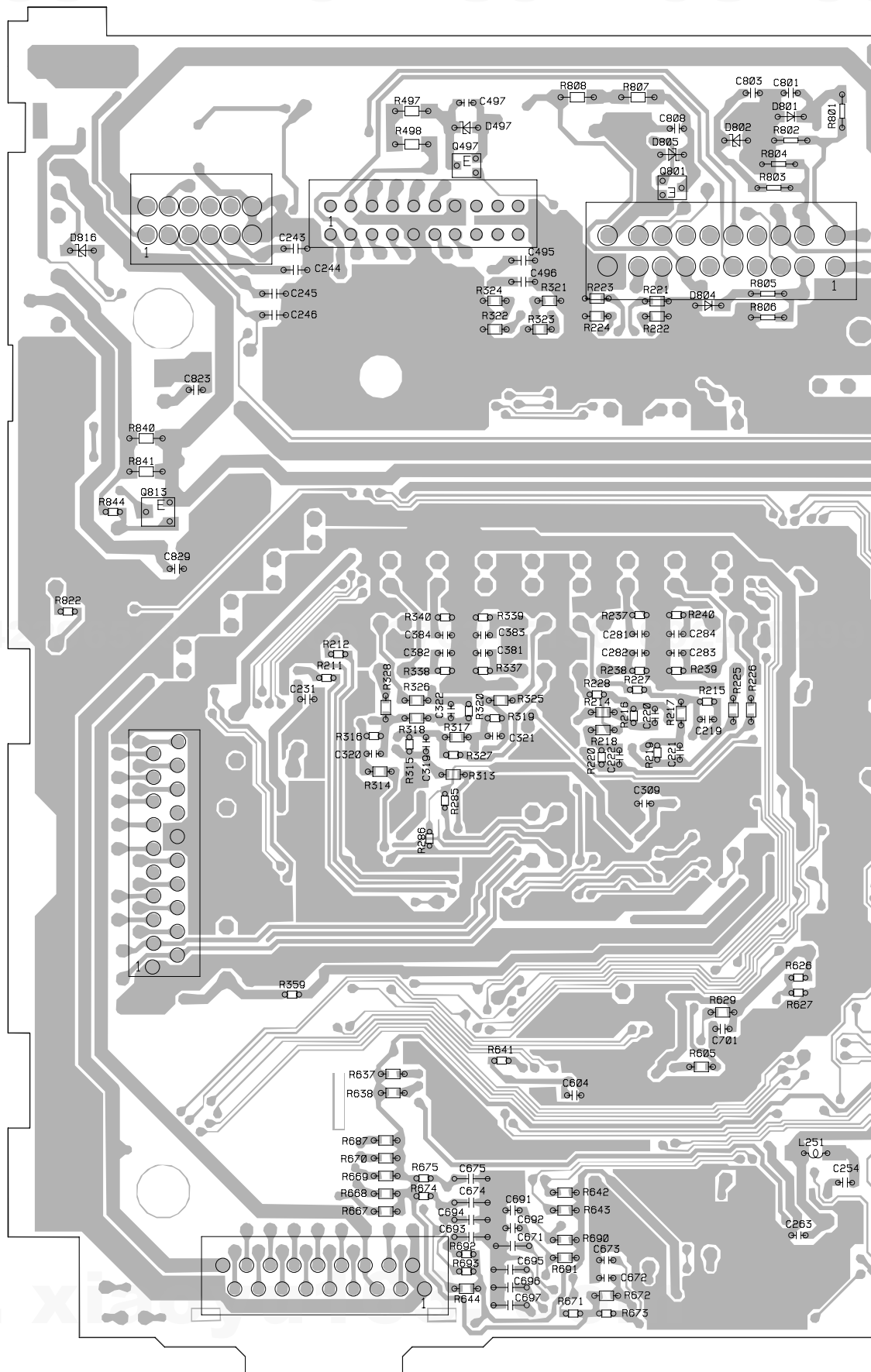

A
B
C
D
E
F

KEX-M8547ZT/EW

A

4.2 KEYBOARD UNIT(KEX-M8547ZT/EW)

B KEYBOARD UNIT **SIDE A**

B KEYBOARD UNIT **SIDE B**

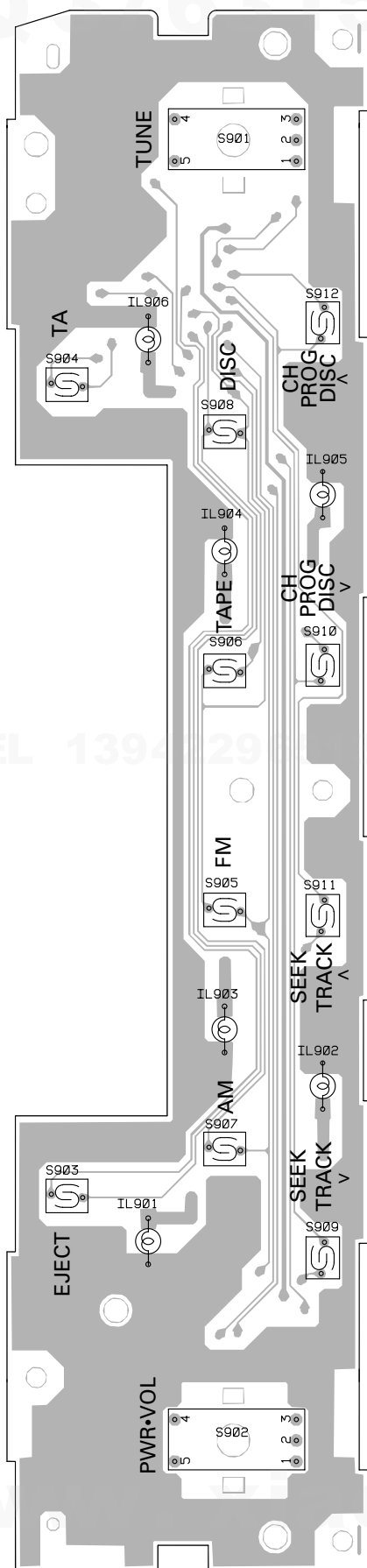

A
CN804

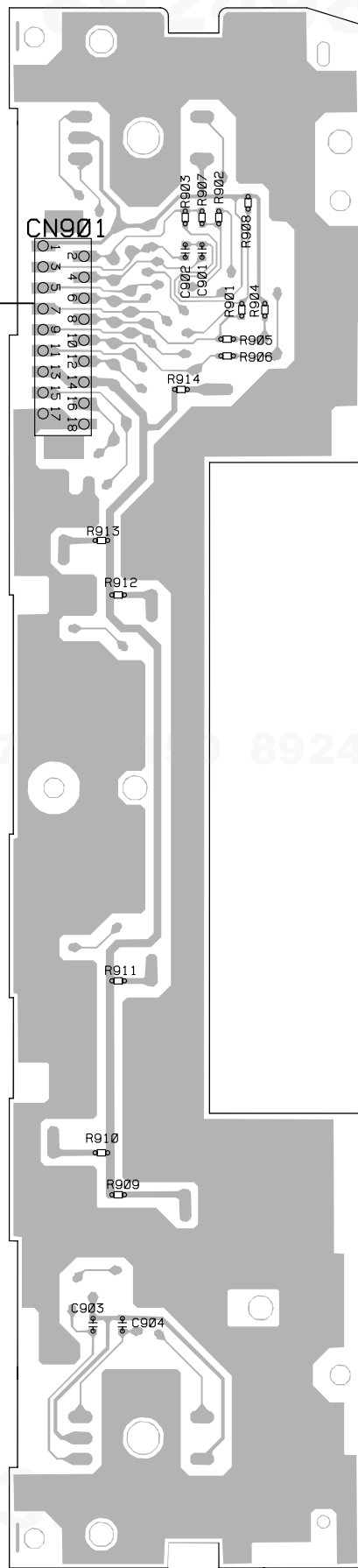

A
B
C
D
E
F

4.3 KEYBOARD UNIT(KEX-M8647ZT/EW)

B KEYBOARD UNIT **SIDE A**

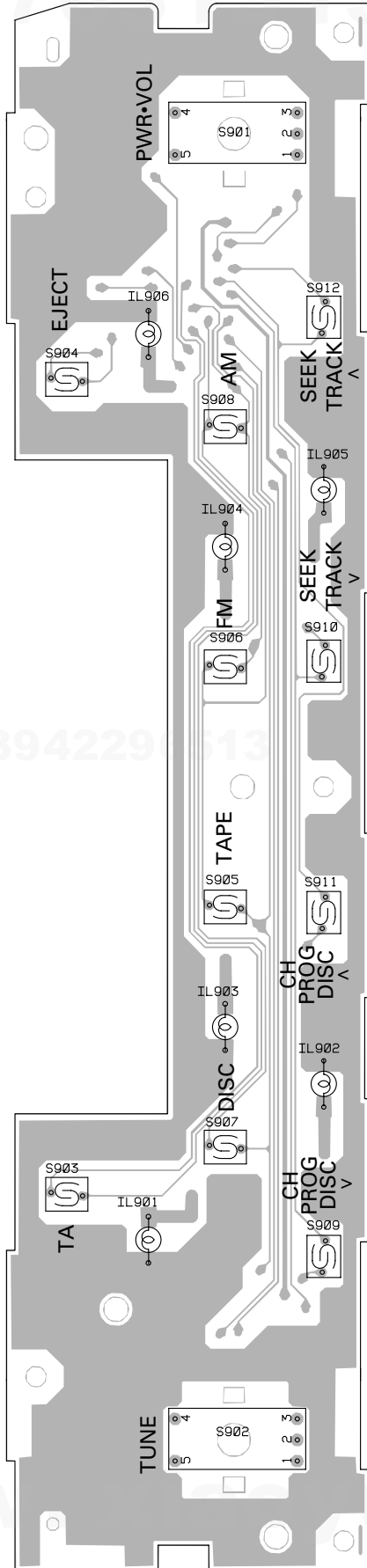

B KEYBOARD UNIT **SIDE B**

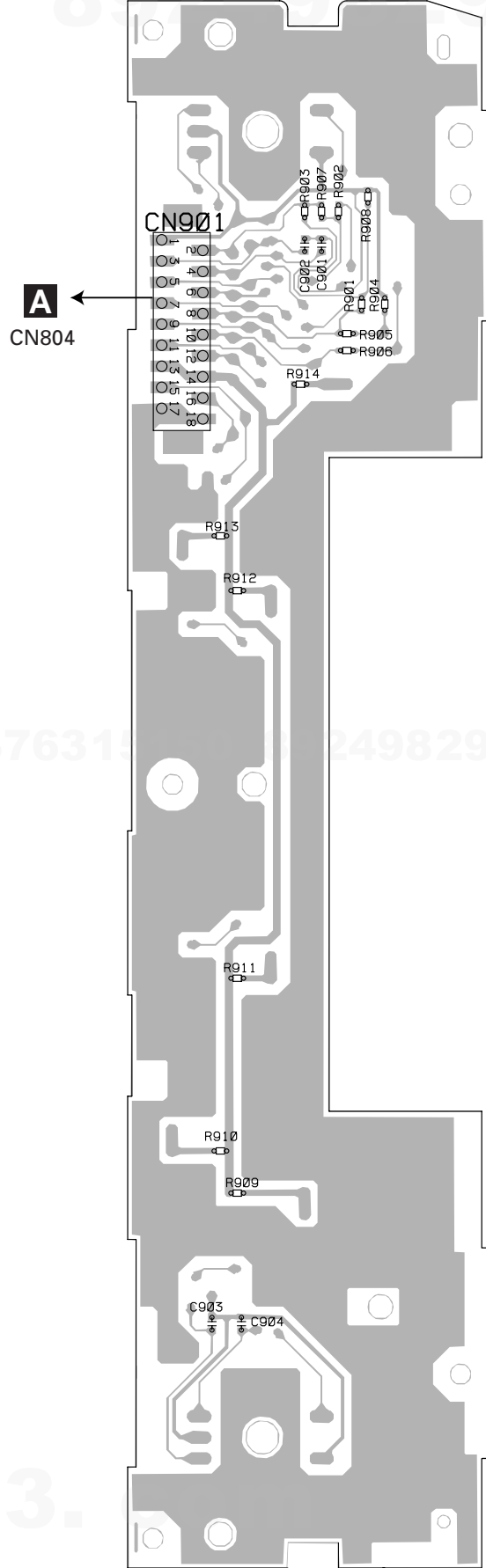

4.4 CASSETTE MECHANISM MODULE

C DECK UNIT

SIDE A

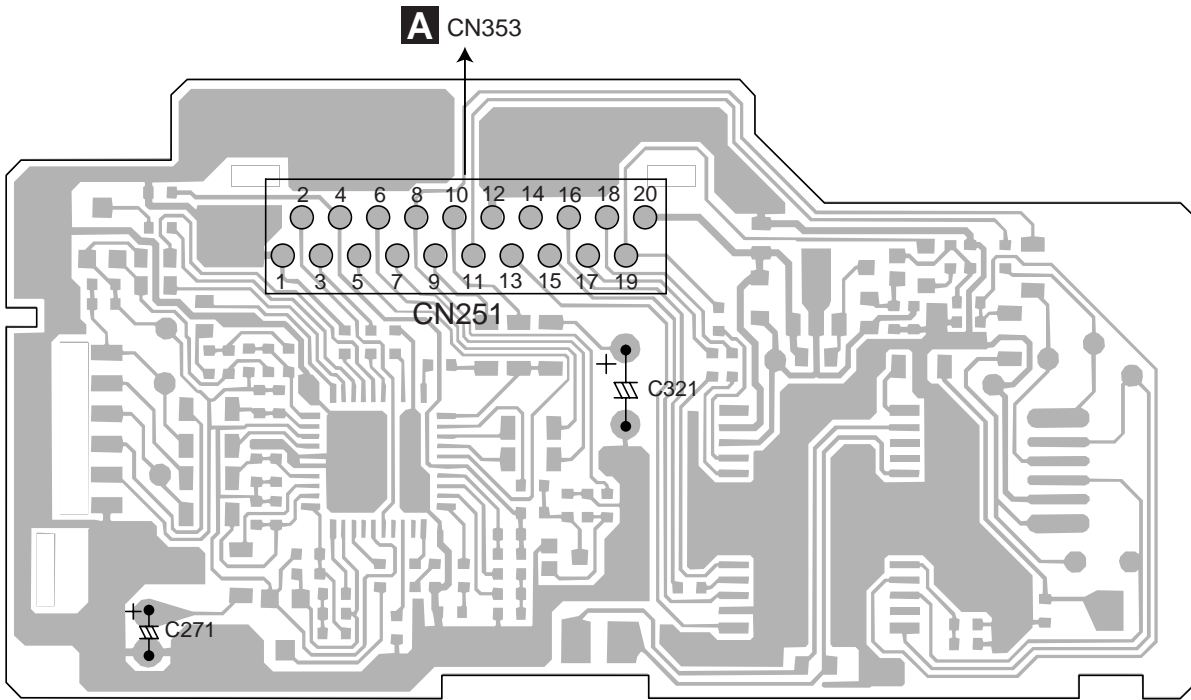

C DECK UNIT

SIDE B

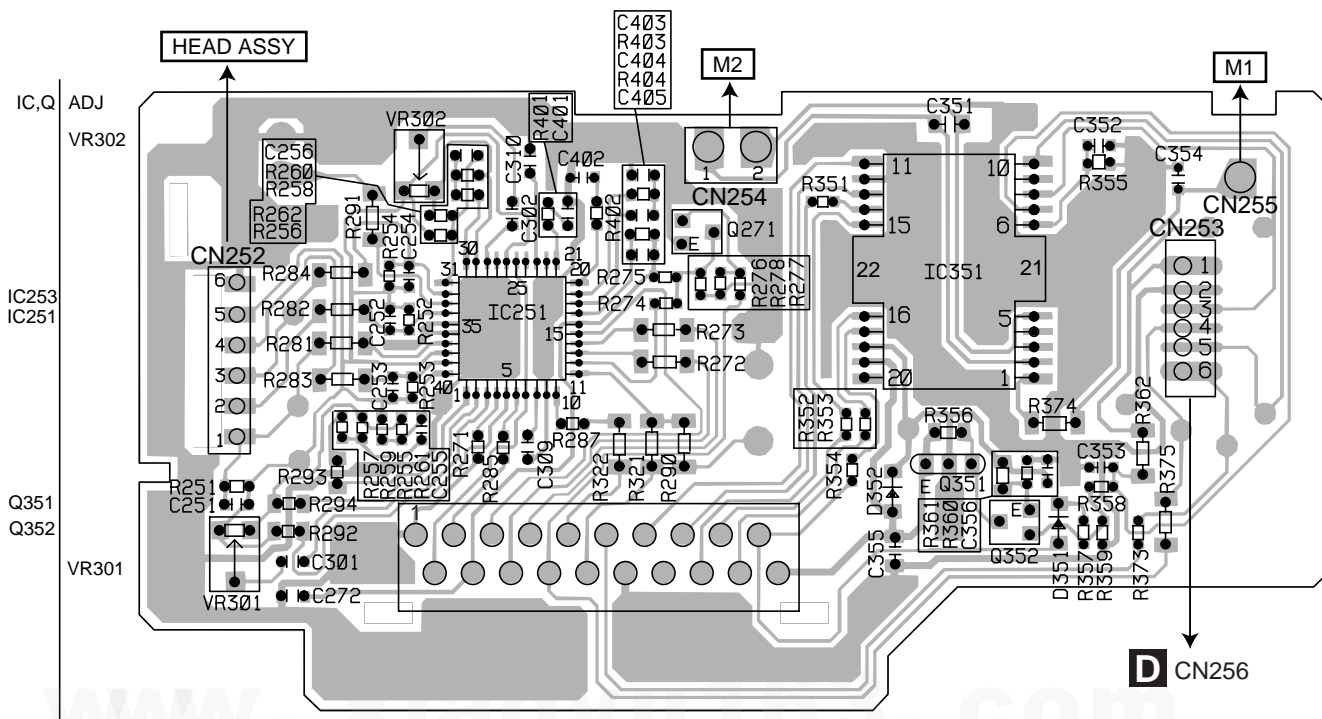

QQ 376315150 892498299

D SENSOR UNIT

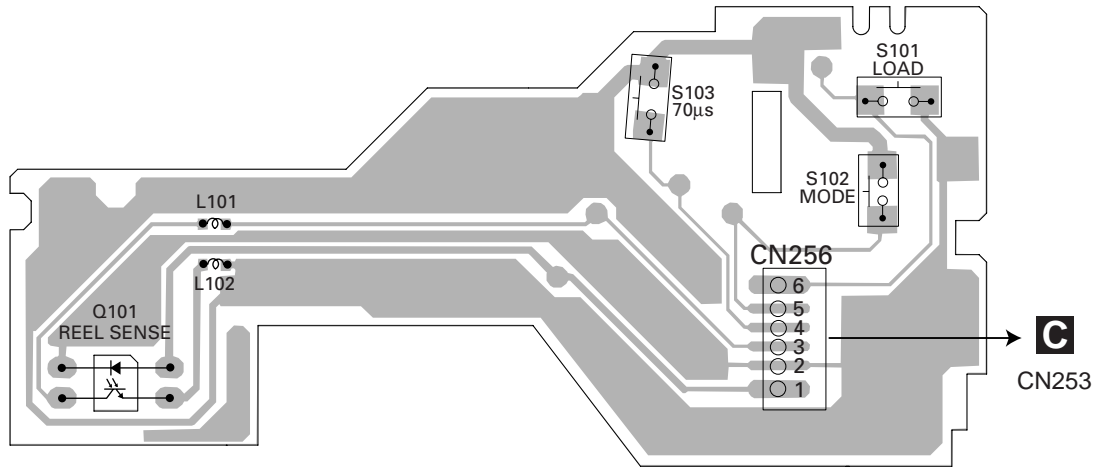

TEL 13942296513 QQ 376315150 892498299

www.xiaoyu163.com

www.xiaoyu163.com

www.xiaoyu163.com

TEL 13942296513

QQ 376315150 892498299

www.xiaoyu163.com

D

5. ELECTRICAL PARTS LIST

NOTE:

- Parts whose parts numbers are omitted are subject to being not supplied.
- The part numbers shown below indicate chip components.

Chip Resistor

RS1/OSOOOJ,RS1/OOSOOOJ

Chip Capacitor (except for CQS.....)

CKS....., CCS....., CSZS.....

Circuit Symbol and No.	Part No.	Circuit Symbol and No.	Part No.
------------------------	----------	------------------------	----------

Q 403	Transistor	FMG13
Q 404	Transistor	DTA114EU
Q 405	Transistor	DTC143TU
Q 406	Transistor	IMH3A
Q 451	Transistor	2SB1260
Q 452	Transistor	2SC2712
Q 453	Transistor	2SC2712
Q 497	Transistor	DTC114EU
Q 501	Transistor	IMX1
Q 502	Transistor	2SC2712
Q 561	Transistor	2SC2712
Q 563	Transistor	IMT2A
Q 564	Transistor	IMH1A
Q 565	Transistor	2SB1689
Q 566	Transistor	DTC114EU
Q 644	Transistor	DTC114EU
Q 645	Transistor	2SA1162
Q 801	Transistor	DTC114EU
Q 805	Transistor	DTC144TUA
Q 806	Transistor	DTC144TUA
Q 807	Transistor	DTC144TUA
Q 810	Transistor	2SB1185
Q 811	Transistor	2SB1185
Q 813	Transistor	2SA1162
Q 816	Transistor	IMX1
Q 817	Transistor	IMX1
Q 825	Transistor	2SA1162
Q 860	Transistor	2SA1162
Q 861	Transistor	DTC143EU
Q 862	Transistor	DTC144TUA
Q 863	Transistor	IMD3A
Q 864	Transistor	DTA114EU
Q 865	Transistor	DTA114EU
Q 866	Transistor	DTA114EU
Q 867	Transistor	DTA114EU
Q 870	Transistor	2SD1767
Q 882	Transistor	2SA1162
Q 884	Transistor	DTC124EU
D 101	Diode	CPH5512
D 102	Diode	HZU3R3(B2)
D 115	Diode	1SS355
D 135	Diode	1SS355
D 181	Diode	1SV249
D 182	Diode	1SV249
D 203	Diode	HZU4R7(B2)
D 401	Diode	1SS355
D 452	Diode	1SS355
D 472	Diode	MPG06G-6415G50

A
Unit Number:CWM9554 (M8547ZT)
Unit Number:CWM9555 (M8647ZT)
Unit Name:Main Unit

MISCELLANEOUS

IC 151	IC	LA1061M
IC 201	IC	NJM2068MD
IC 202	IC	TC4052BF
IC 203	IC	NJM2068MD
IC 204	IC	NJM2068MD
IC 252	IC	PM4009A
IC 302	IC	TC4052BF
IC 303	IC	NJM2068MD
IC 304	IC	NJM2068MD
IC 401	IC	NJM2068MD
IC 501	IC	LA1061M
IC 561	IC	HA12181FP
IC 562	IC	NJM2068MD
IC 601	IC	PD5945A
IC 602	IC	S-80835CNNB-B8U
IC 701	IC	HA12187FP
IC 870	IC	S-812C56AUA-C3K
Q 121	Transistor	2SC3356
Q 126	Transistor	2SC3356
Q 141	Transistor	2SC3356
Q 146	Transistor	2SC3356
Q 161	Transistor	IMX1
Q 171	Transistor	2SB1260
Q 172	Transistor	UMX1N
Q 181	Transistor	DTC144EU
Q 182	Transistor	2SC4081
Q 183	Transistor	2SA1576
Q 201	Transistor	DTC144EU
Q 202	Transistor	DTC144EU
Q 203	Transistor	DTC144EU
Q 204	Transistor	FMG13
Q 205	Transistor	FMG13
Q 252	Transistor	2SC3052-12
Q 301	Transistor	DTC144EU
Q 302	Transistor	DTC144EU
Q 303	Transistor	DTC144EU
Q 304	Transistor	FMG13
Q 305	Transistor	FMG13
Q 401	Transistor	IMX1
Q 402	Transistor	FMG13

<u>Circuit Symbol and No.</u>		<u>Part No.</u>	<u>Circuit Symbol and No.</u>		<u>Part No.</u>
D 473	Diode	MPG06G-6415G50	L 514	Inductor	CTF1473
D 474	Diode	1SS355	L 561	Inductor	CTF1473
D 475	Diode	1SS355	L 601	Inductor	LCTA100J3225
D 497	Diode	UDZS20(B)	L 801	Coil 350μH	CTH1276
D 502	Diode	CPH5512	T 121	Coil	CTC1187
D 562	Diode	UDZS10(B)	T 126	Coil	CTC1187
D 563	Diode	UDZS10(B)	T 141	Coil	CTC1187
D 691	Diode	1SS355	T 146	Coil	CTC1187
D 692	Diode	1SS355	T 501	Coil	CTB1102
D 693	Diode	1SS355	X 251	Crystal Resonator 3.648MHz	CSS1447
D 703	Diode	UDZS18(B)	X 601	Radiator 10.0MHz	CSS1577
D 704	Diode	UDZS18(B)	VR561	Semi-fixed 10kΩ(B)	CCP1396
D 801	Diode	1SS355	FU471	Fuse 5A	CEK1216
D 802	Diode	UDZS5R6(B)		FM Tuner Unit	CWE1679
D 803	Diode	RM4LFJ10		FM/AM Tuner Unit	CWE1773
D 804	Diode	1SS355			
D 805	Diode	UDZS20(B)			
RESISTORS					
D 808	Diode	HZU8R2(B2)	R 13		RS1/16S100J
D 809	Diode	HZU7R5(B3)	R 14		RS1/16S100J
D 810	Diode	HZU8R2(B2)	R 15		RS1/16S100J
D 815	Diode	1SS355	R 16		RS1/16S100J
D 816	Diode	HZU7R5(B3)	R 101		RS1/16S102J
D 860	Diode	HZU8R2(B3)	R 103		RS1/16S681J
D 861	Diode	1SS355	R 104		RS1/16S153J
D 862	Diode	1SS355	R 105		RS1/16S681J
D 863	Diode	DAP202K	R 106		RS1/16S681J
D 864	Diode	1SS355	R 107		RS1/16S681J
D 870	Diode	MPG06G-6415G50	R 108		RS1/16S681J
D 871	Diode	UDZS16(B)	R 109		RS1/16S102J
D 882	Diode	1SS355	R 110		RS1/16S473J
ZNR501	Surge Protector	RCCA-201Q31UA-PI	R 112		RS1/16S472J
ZNR502	Surge Protector	RCCA-201Q31UA-PI	R 113		RS1/16S473J
L 32	Inductor	LCYB12NJ1608	R 115		RS1/16S331J
L 33	Inductor	LCYB12NJ1608	R 117		RS1/16S681J
L 101	Inductor	CTF1409	R 121		RS1/16S100J
L 104	Inductor	CTF1473	R 122		RS1/16S222J
L 115	Inductor	LCYBR12J1608	R 123		RS1/16S121J
L 116	Inductor	LCYBR12J1608	R 124		RS1/16S220J
L 122	Inductor	LCYBR10J1608	R 125		RS1/16S100J
L 127	Inductor	LCYBR10J1608	R 126		RS1/16S100J
L 135	Inductor	LCYBR12J1608	R 127		RS1/16S222J
L 136	Inductor	LCYBR12J1608	R 128		RS1/16S121J
L 142	Inductor	LCYBR10J1608	R 129		RS1/16S220J
L 147	Inductor	LCYBR10J1608	R 130		RS1/16S100J
L 151	Inductor	CTF1409	R 135		RS1/16S331J
L 152	Inductor	CTF1409	R 141		RS1/16S100J
L 153	Inductor	CTF1473	R 142		RS1/16S222J
L 161	Inductor	LCTA561J4532	R 143		RS1/16S121J
L 251	Inductor	LCTA101J2520	R 144		RS1/16S220J
L 363	Inductor	LFEA4R7J	R 145		RS1/16S100J
L 491	Inductor	CTF1578	R 146		RS1/16S100J
L 492	Inductor	CTF1578	R 147		RS1/16S222J
L 501	Inductor	LCTA4R7J2520	R 148		RS1/16S121J
L 507	Inductor	CTF1409	R 149		RS1/16S220J
L 508	Inductor	CTF1409	R 150		RS1/16S100J
L 509	Inductor	CTF1409	R 151		RS1/16S104J
L 510	Inductor	LCTA561J4532	R 152		RS1/16S103J
L 511	Inductor	CTF1473	R 153		RS1/16S103J
L 512	Inductor	LCTA1R0J2520	R 154		RS1/16S334J
L 513	Inductor	CTF1473			

Circuit Symbol and No.

Part No.

Circuit Symbol and No.

Part No.

R 155	RS1/16S101J	R 241	RS1/16S222J
R 156	RS1/16S101J	R 243	RS1/10S103J
R 157	RS1/16S104J	R 244	RS1/10S103J
R 158	RS1/16S104J	R 245	RS1/10S103J
R 161	RS1/16S683J	R 246	RS1/10S103J
R 162	RS1/16S224J	R 247	RS1/16S223J
R 163	RS1/16S473J	R 248	RS1/16S223J
R 164	RS1/16S473J	R 249	RS1/16S223J
R 165	RS1/16S182J	R 250	RS1/16S223J
R 166	RS1/16S103J	R 251	RS1/16S153J
R 171	RS1/16S152J	R 252	RS1/16S474J
R 172	RS1/16S822J	R 253	RS1/16S681J
R 174	RS1/16S472J	R 254	RS1/16S0R0J
R 175	RS1/16S223J	R 257	RS1/16S102J
R 176	RS1/16S103J	R 261	RS1/16S225J
R 178	RS1/10S2R2J	R 285	RS1/16S104J
R 181	RS1/16S102J	R 286	RS1/16S104J
R 182	RS1/16S223J	R 313	RS1/16S163J
R 183	RS1/16S102J	R 314	RS1/16S163J
R 184	RS1/16S102J	R 315	RS1/16S163J
R 185	RS1/16S472J	R 316	RS1/16S163J
R 186	RS1/16S101J	R 317	RS1/16S163J
R 187	RS1/16S223J	R 318	RS1/16S163J
R 201	RS1/16S223J	R 319	RS1/16S163J
R 202	RS1/16S223J	R 320	RS1/16S163J
R 203	RS1/16S223J	R 321	RS1/16S103J
R 204	RS1/16S223J	R 322	RS1/16S103J
R 205	RS1/16S223J	R 323	RS1/16S103J
R 206	RS1/16S223J	R 324	RS1/16S103J
R 207	RS1/16S223J	R 325	RS1/16S181J
R 208	RS1/16S223J	R 326	RS1/16S181J
R 211	RS1/16S101J	R 327	RS1/16S181J
R 212	RS1/16S101J	R 328	RS1/16S181J
R 213	RS1/16S163J	R 329	RS1/10S470J
R 214	RS1/16S163J	R 330	RS1/10S470J
R 215	RS1/16S163J	R 331	RS1/10S470J
R 216	RS1/16S163J	R 332	RS1/10S470J
R 217	RS1/16S163J	R 333	RS1/16S473J
R 218	RS1/16S163J	R 334	RS1/16S473J
R 219	RS1/16S163J	R 335	RS1/16S473J
R 220	RS1/16S163J	R 337	RS1/16S473J
R 221	RS1/16S103J	R 338	RS1/16S473J
R 222	RS1/16S103J	R 339	RS1/16S473J
R 223	RS1/16S103J	R 340	RS1/16S473J
R 224	RS1/16S103J	R 359	RS1/16S100J
R 225	RS1/16S181J	R 401	RS1/16S432J
R 226	RS1/16S181J	R 402	RS1/16S432J
R 227	RS1/16S181J	R 405	RS1/16S224J
R 228	RS1/16S181J	R 407	RS1/16S102J
R 229	RS1/10S470J	R 408	RS1/16S102J
R 230	RS1/10S470J	R 409	RS1/16S222J
R 231	RS1/10S470J	R 410	RS1/16S222J
R 232	RS1/10S470J	R 411	RS1/16S224J
R 233	RS1/16S473J	R 412	RS1/16S224J
R 234	RS1/16S473J	R 413	RS1/16S102J
R 235	RS1/16S473J	R 414	RS1/16S102J
R 237	RS1/16S473J	R 417	RS1/16S753J
R 238	RS1/16S473J	R 418	RS1/16S753J
R 239	RS1/16S473J	R 427	RS1/16S123J
R 240	RS1/16S473J	R 428	RS1/16S123J

Circuit Symbol and No.**Part No.****Circuit Symbol and No.****Part No.**

R 429	RS1/16S823J	R 566	RS1/16S222J
R 430	RS1/16S823J	R 567	RS1/16S822J
R 431	RS1/16S473J	R 568	RS1/16S222J
R 432	RS1/16S473J	R 569	RS1/16S164J
R 433	RS1/16S101J	R 570	RS1/16S223J
R 451	RS1/16S102J	R 571	RS1/16S473J
R 452	RS1/16S223J	R 572	RS1/16S472J
R 453	RS1/16S823J	R 573	RS1/16S332J
R 454	RS1/16S181J	R 574	RS1/16S332J
R 455	RS1/16S181J	R 575	RS1/16S332J
R 456	RS1/16S181J	R 576	RS1/16S683J
R 457	RS1/16S181J	R 577	RS1/16S332J
R 458	RS1/16S181J	R 578	RS1/16S683J
R 459	RS1/16S223J	R 579	RS1/16S221J
R 460	RS1/16S223J	R 580	RS1/16S221J
R 497	RS1/4S121J	R 581	RS1/16S683J
R 498	RS1/4S121J	R 582	RS1/16S332J
R 500	RS1/16S471J	R 583	RS1/16S332J
R 506	RS1/16S104J	R 584	RS1/16S332J
R 507	RS1/16S103J	R 585	RS1/16S332J
R 508	RS1/16S103J	R 588	RS1/16S562J
R 509	RS1/16S334J	R 603	RS1/16S102J
R 510	RS1/16S101J	R 604	RS1/16S681J
R 511	RS1/16S101J	R 605	RS1/16S102J
R 512	RS1/16S104J	R 606	RS1/16S0R0J
R 513	RS1/16S104J	R 607	RS1/16S104J
R 514	RS1/16S103J	R 608	RS1/16S102J
R 515	RS1/16S182J	R 609	RS1/16S681J
R 516	RS1/16S683J	R 610	RS1/16S0R0J
R 517	RS1/16S224J	R 611	RS1/16S0R0J
R 518	RS1/16S473J	R 612	RS1/16S102J
R 519	RS1/16S473J	R 616	RS1/16S473J
R 520	RS1/16S102J	R 620	RS1/16S0R0J
R 522	RS1/16S222J	R 621	RS1/16S681J
R 525	RS1/16S473J	R 622	RS1/16S0R0J
R 526	RS1/16S681J	R 624	RS1/16S0R0J
R 527	RS1/16S681J	R 625	RS1/16S681J
R 528	RS1/16S681J	R 626	RS1/16S473J
		(M8547ZT)	
R 529	RS1/16S103J	R 627	RS1/16S473J
R 530	RS1/16S681J	R 629	RS1/16S472J
R 531	RS1/16S473J	R 631	RS1/16S0R0J
R 532	RS1/16S473J	R 632	RS1/16S102J
R 533	RS1/16S472J	R 633	RS1/16S102J
		(M8647ZT)	
R 534	RS1/16S393J	R 634	RS1/16S102J
R 535	RS1/16S473J	R 635	RS1/16S471J
R 536	RS1/16S103J	R 637	RS1/16S102J
R 537	RS1/16S473J	R 638	RS1/16S102J
R 538	RS1/16S681J	R 641	RS1/16S473J
R 539	RS1/16S681J	R 642	RS1/16S104J
R 541	RS1/16S681J	R 643	RS1/16S104J
R 542	RS1/16S681J	R 644	RS1/16S473J
R 543	RS1/16S681J	R 645	RS1/16S102J
R 544	RS1/16S681J	R 646	RS1/16S103J
R 545	RS1/16S473J	R 647	RS1/16S102J
R 546	RS1/16S103J	R 648	RS1/16S102J
R 561	RS1/16S104J	R 654	RS1/16S102J
R 562	RS1/16S123J	R 655	RS1/16S102J
R 563	RS1/16S105J	R 656	RS1/16S102J
R 564	RS1/16S562J	R 657	RS1/16S102J
R 565	RS1/16S223J	R 658	RS1/16S223J

Circuit Symbol and No.

Part No.

Circuit Symbol and No.

Part No.

A	R 659	RS1/16S102J	R 840	RS1/4S1R5J
	R 660	RS1/16S102J	R 841	RS1/4S1R5J
	R 661	RS1/16S102J	R 844	RS1/16S471J
	R 662	RS1/16S102J	R 846	RS1/16S105J
	R 663	RS1/16S102J	R 847	RS1/10S361J
	R 664	RS1/16S102J	R 848	RS1/16S272J
	R 665	RS1/16S102J	R 849	RS1/16S392J
	R 666	RS1/16S681J	R 856	RS1/16S103J
	R 667	RS1/16S473J	R 857	RS1/16S103J
	R 668	RS1/16S473J	R 860	RS1/16S223J
	R 669	RS1/16S473J	R 861	RS1/16S103J
	R 670	RS1/16S473J	R 862	RS1/16S104J
	R 671	RS1/16S473J	R 863	RS1/16S223J
B	R 672	RS1/16S473J	R 865	RS1/16S103J
	R 673	RS1/16S473J	R 867	RS1/16S472J
	R 674	RS1/16S473J	R 868	RS1/16S102J
	R 675	RS1/16S473J	R 869	RS1/16S102J
	R 676	RS1/16S102J	R 870	RS1/10S102J
	R 677	RS1/16S102J	R 871	RS1/16S472J
	R 678	RS1/16S102J	R 882	RD1/4PU121J
	R 679	RS1/16S102J	R 884	RS1/16S223J
	R 680	RS1/16S102J	R 886	RS1/16S472J
	R 681	RS1/16S102J	R 888	RS1/16S473J
C	R 682	RS1/16S102J	CAPACITORS	
	R 683	RS1/16S102J	C 32	CCSRCH100D50
	R 684	RS1/16S102J	C 33	CCSRCH100D50
	R 685	RS1/16S102J	C 101	CKSRYB102K50
	R 687	RS1/16S473J	C 102	CKSRYB472K50
	R 690	RS1/16S473J	C 103	CKSRYB102K50
	R 691	RS1/16S473J		
	R 692	RS1/16S473J	C 104	CKSRYB104K25
	R 693	RS1/16S473J	C 105	CKSRYB102K50
	R 698	RS1/16S102J	C 107	CKSRYB105K10
			C 115	CCSRCH270J50
			C 116	CCSRCH150J50
D	R 699	RS1/16S473J		
	R 701	RS1/16S473J		
	R 703	RS1/4S101J	C 117	CCSRCH100D50
	R 704	RS1/4S101J	C 118	CCSRCK2R0C50
	R 705	RS1PMF680J	C 120	CKSRYB103K50
			C 121	CKSRYB222K50
	R 711	RS1/16S473J	C 122	CKSRYB472K50
	R 751 (M8647ZT)	RS1/16S822J		
	R 801	RS1/8S222J	C 123	CCSRCH120J50
	R 802	RS1/8S472J	C 124	CKSRYB102K50
	R 803	RS1/8S472J	C 126	CKSRYB222K50
			C 127	CKSRYB472K50
			C 128	CCSRCH120J50
E	R 804	RS1/8S472J		
	R 805	RS1/8S472J		
	R 806	RS1/8S472J	C 129	CKSRYB102K50
	R 807	RS1/4S121J	C 135	CCSRCH270J50
	R 808	RS1/4S121J	C 136	CCSRCH150J50
			C 137	CCSRCH100D50
			C 138	CCSRCK2R0C50
	R 810	RS1/16S104J		
	R 811	RS1/16S104J		
	R 812	RS1/16S104J	C 140	CKSRYB103K50
	R 820	RS1/16S123J	C 141	CKSRYB222K50
	R 821	RS1/16S103J	C 142	CKSRYB472K50
			C 143	CCSRCH120J50
			C 144	CKSRYB102K50
	R 822	RS1/16S103J		
	R 834	RS1/16S223J		
	R 835	RS1/16S221J	C 146	CKSRYB222K50
F	R 836	RS1/16S331J	C 147	CKSRYB472K50
	R 837	RS1/16S681J	C 148	CCSRCH120J50
			C 149	CKSRYB102K50
			C 151	CKSRYB472K50
	R 838	RS1/16S471J		
	R 839	RS1/16S151J		

Circuit Symbol and No.**Part No.****Circuit Symbol and No.****Part No.**

C 152		CKSRYP103K50	C 261		CCSRCH471J50
C 153		CKSYB106K6R3	C 262		CEJQ4R7M35
C 154		CKSRYP105K10	C 263		CKSRYP473K50
C 155		CKSRYP102K50	C 281		CKSRYP182K50
C 156		CKSQYB225K10	C 282		CKSRYP182K50
C 157		CKSRYP103K50	C 283		CKSRYP182K50
C 158		CKSRYP102K50	C 284		CKSRYP182K50
C 161		CKSRYP392K50	C 285		CCSRCH391J50
C 162		CKSRYP103K50	C 286		CCSRCH391J50
C 163		CKSRYP103K50	C 309		CKSRYP102K50
C 171		CKSRYP104K16	C 310		CKSRYP105K10
C 172		CKSRYP103K50	C 319		CCSRCH220J50
C 173		CKSRYP103K50	C 320		CCSRCH220J50
C 181		CKSRYP105K10	C 321		CCSRCH220J50
C 182		CKSRYP103K50	C 322		CCSRCH220J50
C 183		CKSRYP222K50	C 323	4.7μF/35V	CCH1432
C 184		CKSRYP222K50	C 324	4.7μF/35V	CCH1432
C 201		CEJQNP4R7M16	C 325	4.7μF/35V	CCH1432
C 202		CEJQNP4R7M16	C 326	4.7μF/35V	CCH1432
C 203		CEJQNP4R7M16	C 327		CCSRCH221J50
C 204		CEJQNP4R7M16	C 328		CCSRCH221J50
C 205		CCSRCH330J50	C 329		CCSRCH221J50
C 206		CCSRCH330J50	C 330		CCSRCH221J50
C 207		CCSRCH330J50	C 335	4.7μF/35V	CCH1432
C 208		CCSRCH330J50	C 336	4.7μF/35V	CCH1432
C 209		CKSRYP102K50	C 337	4.7μF/35V	CCH1432
C 210		CKSRYP105K10	C 338	4.7μF/35V	CCH1432
C 215		CEJQNP4R7M16	C 351		CEJQ4R7M35
C 216		CEJQNP4R7M16	C 355		CEJQ220M10
C 219		CCSRCH220J50	C 356		CEJQ100M16
C 220		CCSRCH220J50	C 381		CKSRYP182K50
C 221		CCSRCH220J50	C 382		CKSRYP182K50
C 222		CCSRCH220J50	C 383		CKSRYP182K50
C 223	4.7μF/35V	CCH1432	C 384		CKSRYP182K50
C 224	4.7μF/35V	CCH1432	C 401		CKSRYP123K50
C 225	4.7μF/35V	CCH1432	C 402		CKSRYP123K50
C 226	4.7μF/35V	CCH1432	C 403	4.7μF/35V	CCH1432
C 227		CCSRCH221J50	C 404	4.7μF/35V	CCH1432
C 228		CCSRCH221J50	C 405		CKSRYP153K50
C 229		CCSRCH221J50	C 406		CKSRYP102K50
C 230		CCSRCH221J50	C 411		CKSRYP104K16
C 231		CKSRYP473K50	C 412		CKSRYP104K16
C 232		CEJQ101M6R3	C 415		CKSRYP105K10
C 233		CKSRYP102K50	C 416		CKSRYP105K10
C 235	4.7μF/35V	CCH1432	C 417		CCSRCH391J50
C 236	4.7μF/35V	CCH1432	C 418		CCSRCH391J50
C 237	4.7μF/35V	CCH1432	C 421		CEJQ470M6R3
C 238	4.7μF/35V	CCH1432	C 451		CKSRYP222K50
C 243		CKSQYB102K50	C 480		CKSQYB102K50
C 244		CKSQYB102K50	C 493		CCSQCH181J50
C 245		CKSQYB102K50	C 494		CCSQCH181J50
C 246		CKSQYB102K50	C 495		CKSQYB102K50
C 251		CKSRYP104K16	C 496		CKSQYB102K50
C 252		CKSRYP472K50	C 497		CCSRCH221J50
C 253		CEJQ220M6R3	C 503		CKSQYB103K50
C 254		CKSRYP104K16	C 504		CKSRYP102K50
C 256		CCSRCH270J50	C 506		CCSRCH100D50
C 257		CCSRCH270J50	C 507		CKSRYP472K50
C 259		CKSRYP104K16	C 508		CKSRYP103K50
C 260		CCSRCH471J50	C 509		CKSRYP103K50

Circuit Symbol and No.

Part No.

Circuit Symbol and No.

Part No.

A	C 510	CKSYB106K6R3
	C 511	CKSRYB472K50
	C 512	CEV100M16
	C 513	CKSRYB102K50
	C 514	CKSQYB225K10
	C 515	CKSRYB102K50
	C 516	CKSRYB103K50
	C 517	CKSRYB103K50
	C 518	CKSRYB392K50
	C 519	CKSRYB103K50
	C 520	CKSRYB103K50
	C 521	CEV101M10
B	C 522	CKSRYB103K50
	C 523	CEJQ100M16
	C 524	CKSRYB472K50
	C 525	CKSRYB102K50
	C 561	CEJQ3R3M50
	C 562	CKSRYB333K16
	C 563	CEJQNP1R0M50
	C 564	CQMA683J50
	C 565	CQMA333J50
	C 566	CQMA333J50
	C 567	CQMA333J50
	C 568	CKSRYB105K10
C	C 569	CKSRYB333K16
	C 570	CKSRYB123K50
	C 571	CKSRYB682K50
	C 572	CEJQ101M10
	C 573	CKSRYB392K50
	C 574	CKSRYB334K10
	C 575	CKSRYB102K50
	C 576	CCSRCH151J50
	C 579	CCSRCH470J50
	C 580	CCSRCH470J50
D	C 581	CCSRCH470J50
	C 582	CKSRYB473K50
	C 583	CKSRYB473K50
	C 584	CKSRYB473K50
	C 585	CKSRYB223K50
	C 586	CKSRYB223K50
	C 587	CKSRYB104K16
	C 601	CKSRYB102K50
	C 602	CKSRYB103K50
	C 603	CKSRYB103K50
	C 604	CKSRYB104K16
E	C 605	CEJQ220M6R3
	C 645	CKSRYB103K50
	C 648	CKSRYB102K50
	C 671	CCSRCH101J50
	C 672	CCSRCH101J50
	C 673	CCSRCH101J50
	C 674	CCSRCH101J50
	C 675	CCSRCH101J50
	C 691	CKSRYB102K50
	C 692	CKSRYB102K50
F	C 693	CKSRYB102K50
	C 694	CKSRYB102K50
	C 695	CKSRYB102K50
	C 696	CKSRYB102K50
	C 697	CKSRYB102K50

C 701	CKSRYB103K50
C 703	CCSRCH221J50
C 704	CCSRCH221J50
C 801	CKSRYB102K50
C 802	CEJQ1R0M50
C 803	CKSRYB102K50
C 804	2200µF/16V
C 805	CCH1405(P35)
C 806	CKSQYB473K50
C 807	CKSRYB102K50
	CEJQ1R0M50
C 808	CKSRYB102K50
C 814	CEJQ1R0M50
C 815	CEJQ1R0M50
C 821	CKSRYB103K50
C 822	100µF/10V
C 823	CKSRYB103K50
C 824	CKSRYB472K50
C 825	100µF/10V
C 829	CCH1402
C 861	CKSRYB103K50
	CEJQ101M6R3
C 866	CEJQ100M16
C 867	CEJQ100M16
C 870	CKSRYB103K50
C 871	CKSRYB103K50
C 872	2200µF/16V
C 873	CKSRYB105K10
C 883	CKSRYB103K50

B
Unit Number:CWS1338(M8547ZT)
Unit Number:CWS1339(M8647ZT)
Unit Name:Keyboard Unit

MISCELLANEOUS

S 901	Encoder(M8547ZT)	CSD1083
S 901	Encoder(M8647ZT)	CSD1080
S 902	Encoder(M8547ZT)	CSD1080
S 902	Encoder(M8647ZT)	CSD1083
IL 901	Lamp 8V 85mA	CEL1748
IL 902	Lamp 8V 85mA	CEL1748
IL 903	Lamp 8V 85mA	CEL1748
IL 904	Lamp 8V 85mA	CEL1748
IL 905	Lamp 8V 85mA	CEL1748
IL 906	Lamp 8V 85mA	CEL1748

RESISTORS

R 901	(M8647ZT)	RS1/16S0R0J
R 902	(M8647ZT)	RS1/16S0R0J
R 903	(M8647ZT)	RS1/16S0R0J
R 904	(M8647ZT)	RS1/16S0R0J
R 905	(M8547ZT)	RS1/16S0R0J
R 906	(M8547ZT)	RS1/16S0R0J
R 907		RS1/16S0R0J
R 908	(M8547ZT)	RS1/16S0R0J
R 909		RS1/16S3R3J
R 910		RS1/16S5R6J
R 911		RS1/16S3R3J
R 912		RS1/16S3R3J

Circuit Symbol and No.**Part No.**R 913
R 914RS1/16S5R6J
RS1/16S3R3J**C****Unit Number:EWM1031****Unit Name:Deck Unit****MISCELLANEOUS**IC 251 IC
IC 351 IC
Q 271 Transistor
D 352 Diode
VR301 Semi-fixed 33kΩ(B)

VR302 Semi-fixed 33kΩ(B)HA12216F
PA2020B
2SC4116
1SS355
CCP1280

CCP1280**RESISTORS**R 255
R 256
R 257
R 258
R 259RS1/16S181J
RS1/16S181J
RS1/16S183J
RS1/16S183J
RS1/16S133JR 260
R 261
R 262
R 271
R 272RS1/16S133J
RS1/16S274J
RS1/16S274J
RS1/16S183J
RS1/8S0R0JR 273
R 274
R 275
R 276
R 277RS1/8S0R0J
RS1/16S0R0J
RS1/16S473J
RS1/16S104J
RS1/16S224JR 278
R 281
R 282
R 283
R 284RS1/16S104J
RS1/8S0R0J
RS1/8S0R0J
RS1/8S0R0J
RS1/8S0R0JR 285
R 287
R 291
R 292
R 293RS1/16S0R0J
RS1/16S0R0J
RS1/8S0R0J
RS1/10S0R0J
RS1/10S0R0JR 294
R 321
R 322
R 351
R 352RS1/10S0R0J
RS1/8S0R0J
RS1/8S0R0J
RS1/16S102J
RS1/16S102JR 353
R 354
R 355
R 362
R 373RS1/16S102J
RS1/16S102J
RS1/16S274J
RS1/8S301J
RS1/16S0R0JR 374
R 375
R 401
R 402
R 403RS1/8S0R0J
RS1/8S0R0J
RS1/16S153J
RS1/16S332J
RS1/16S911J

R 404

RS1/16S274J

Circuit Symbol and No.**Part No.****CAPACITORS**C 251
C 252
C 253
C 254
C 255CKSRYB391K50
CKSRYB391K50
CKSRYB391K50
CKSRYB391K50
CKSRYB103K50C 256
C 271
C 272
C 301
C 302

1μF/50V

CKSRYB103K50
ECH0002
CKSRYB104K25
CKSRYB104K25
CKSRYB104K25C 309
C 310
C 351
C 352
C 353CKSRYB104K25
CKSRYB104K25
CKSQYB224K16
CKSRYB392K50
CKSRYB103K50C 354
C 355
C 356
C 401
C 402CKSRYB103K50
CKSQYB104K50
CKSRYB103K50
CKSRYB392K50
CKSRYB334K10C 403
C 404
C 405CKSRYB223K25
CKSRYB103K50
CKSRYB333K16**D****Unit Number:EWM1041****Unit Name:Sensor Unit****MISCELLANEOUS**L 101
L 102
S 101
S 102
S 103Inductor
Inductor
Switch(LOAD)
Switch(MODE)
Switch(70μS)CTF1546
CTF1546
ESG1007
ESG1007
ESG1007

Q 101

Photo-reflector

EGN1004

Miscellaneous Parts ListM 1
M 2
HD1Motor Unit(MAIN)
Motor Unit(SUB)
Head AssyEXA1618
EXA1660
EXA1594

6. ADJUSTMENT

6.1 JIG CONNECTION DIAGRAM

● Connection Diagram TOYOTA EMV SYSTEM MODEL

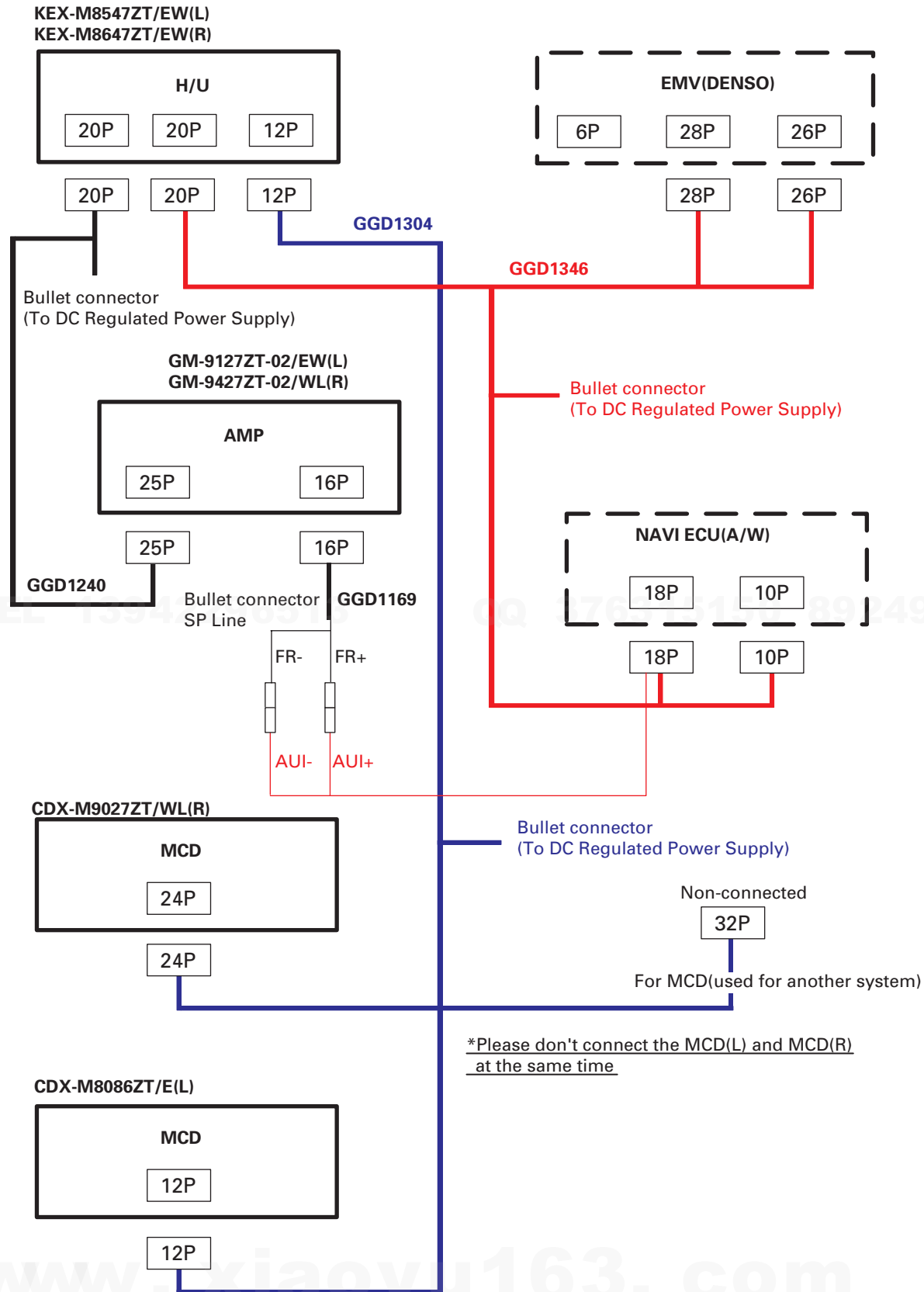

6.2 CASSETTE AND AUDIO ADJUSTMENT



● Connection Diagram

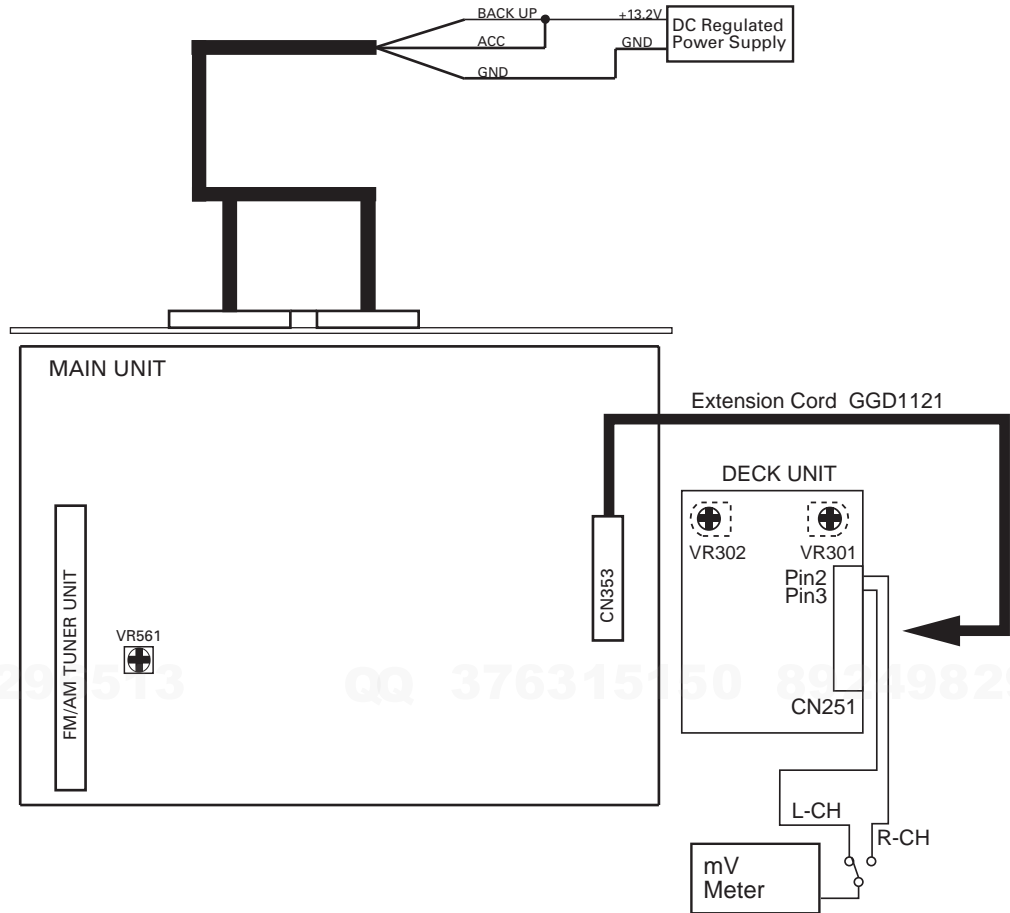

DOLBY B NR ADJUSTMENT

No.	Test Tape	Adjustment Point	Adjustment Method (Switch Position)
1	NCT-150 (400Hz, 200nwb/m)	VR301(Lch), VR302(Rch)	mV Meter : - 8.24dBm ± 1dB (DOLBY NR Switch : OFF)

AM NOISE CANCELER ADJUSTMENT

Connection:

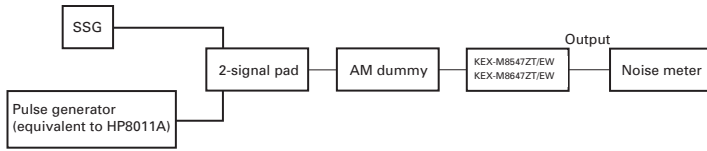

Setting of the pulse generator. (setting of superimposed pulse)

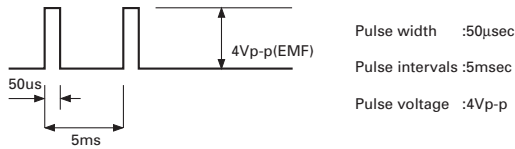

Adjustment:

1. Setting of SSG

Receiving frequency : 999 kHz

Percentage modulation : 30%

Modulation frequency : 400 Hz

Antenna input : 74 dB μ V (EMF)

2. Tune a RADIO to the "999kHz" with 1 condition.

3. Mix signal with the above-mentioned pulse and SSG modulation OFF.

4. Variable resistance adjust noise level to a minimum.

Adjustment point : VR561

6.3 SELF-DIAGNOSIS FUNCTION

1.To Service Check

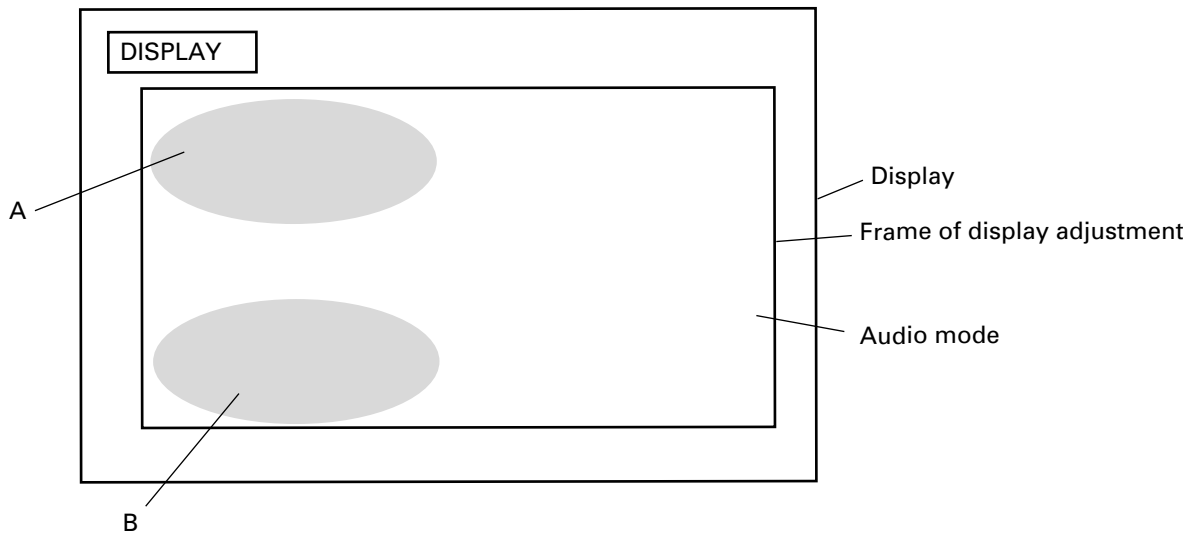

1. Press [AUDIO] key of EMV .
2. Press [DISPV] key of EMV .
3. The position of A and B is order of pushed 6 times in A,B,A,B,A and B.
->Service Check screen is displayed.

2.Service Check

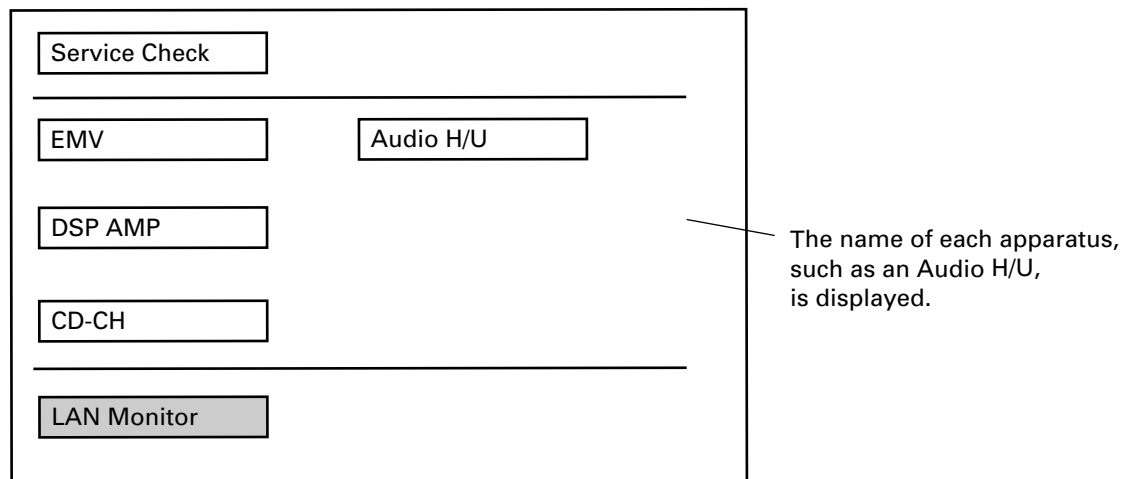

->As it is, it waits for a while.
(In general less than 1 minute)



A

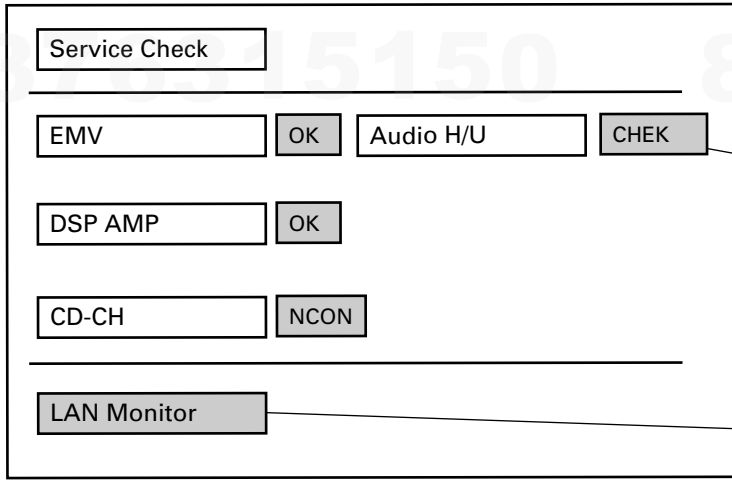

When displayed as [CHEK] or [EXCH], details will be displayed if the portion is touched.

It changes on the screen which displays the abnormalities on communication.

The diagnostic result of each model is displayed.

Results are [OK], [NCON],[CHEK], and [EXCH].

OK : No error code

NCON : EMV has judged it as the thing without connection.

(Disconnection being possible if there is actually connection)

CHEK : An error code indicating that diagnosis is judged to be necessary is entered.

EXCH : An error code indicating that exchange is judged to be necessary is entered.

B

C

D

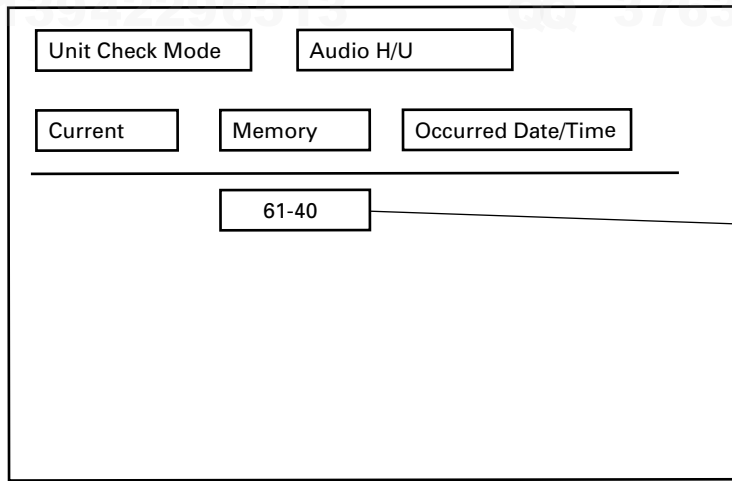

The detected abnormalities (Diagnosis code) are displayed. At this example, it is 40 (abnormalities in mechanism or media) of 61 (= cassette).

3.How to exit from the diagnostic test mode

ACC-OFF

E

F

Diagnosis code table

Logical address name	Logical address	Diagnosis code	Diagnosis details
Communi- cation control	01H	00	No diagnosis
		01	Abnormal reset
		10	Abnormal +B
		11	Abnormal ACC
		12	Abnormal MUTE
		13	Fuse broken
		20	Microcomputer - abnormal
		21	ROM - abnormal
		22	RAM - abnormal
		23	Bus - abnormal
		24	F-ROM - abnormal
		25	V-RAM - abnormal
		26	Gate alloy abnormal
		27	Paint controller abnormal
		28	Backup memory abnormal
		29	Voice output controller abnormal
		2A	Internal power supply abnormal
		30	Sync signal abnormal (input)
		31	Sync signal abnormal (output)
		D0	ECU not connected
		D1	Transmission abnormal
		D2	Connecting confirmation: abnormal
		D4	Connecting confirmation: no response
		D5	Registered device data missing (History of registered devices)
		D6	Master unavailable
		D7	Connecting confirmation: abnormal
		D8	Connecting confirmation: no response
		D9	Last mode abnormal
		DA	Command/order: no response
		DB	Mode status abnormal
		DC	Transmission fault
		DD	Master reset
DE	Slave reset		
DF	Master abnormal		
E0	Registration completion acknowledgement error		
E1	Voice processor ON abnormal		
E2	ON/OFF command or parameter abnormal		
E3	Registration command transmission		
E4	Multiple frames intermit.		
FF	Diagnosis - no response		

Logical address name	Logical address	Diagnosis code	Diagnosis details
Radio	60H	10	AM tuner PLL unlocked
		11	FM tuner PLL unlocked
		40	No antenna connected
		41	Antenna power supply abnormal
		42	Tuner power supply abnormal
		43	AM tuner abnormal
		44	FM tuner abnormal
		45	SW tuner abnormal
		10	TV tuner PLL unlocked
		11	FRONTEND abnormal
40	TV divergence shifting error		
41	TV - no reception		
42	VNR screen error		
43	No antenna connected		
44	Antenna power supply abnormal		
45	SEL + B current - small		
46	SEL + B current - large		
10	Belt broken		
40	Mechanical failure or cassette broken		
41	EJECT failure		
42	TAPE jamming		
43	Dirty head		
44	Mech power supply abnormal		
10	CD Mech abnormal		
11	CD loading/unloading abnormal		
12	CD lead-in abnormal		
40	No disc loaded		
41	Incorrect disc		
42	Disc unreadable		
43	CD-ROM abnormal		
44	GD abnormal		
45	EJECT abnormal		
46	Scratches or non-recorded side		
47	CD high temperature detected		
48	Excessive current detected		
50	Tray IN/OUT abnormal		
51	Elevator abnormal		
52	Clamp abnormal		
10	MD mech abnormal		
11	MD IN/OUT abnormal		
12	MD lead-in abnormal		
40	No disc loaded		
41	Incorrect disc		
42	Disc unreadable		
43	MD-ROM abnormal		
44	MD abnormal		
45	EJECT error		
46	Scratches or non-recorded side		
47	MD high temperature detected		
48	Excessive current detected		
50	Tray IN/OUT abnormal		
51	Elevator abnormal		
52	Clamp abnormal		

Logical address name	Logical address	Diagnosis code	Diagnosis details
Navigation /GPS	58H 80H	10	Gyroscope abnormal
		11	GPS receiver abnormal
		12	RTC abnormal
		13	SS section abnormal
		14	No Time updating
		15	TCXO abnormal
		16	PLL lock abnormal
		40	GPS antenna abnormal
		41	GPS antenna power supply abnormal
		42	Map disc reading abnormal
		43	SFD signal abnormal
		44	Player abnormal
		45	High temperature abnormal
		41	Antenna power supply abnormal
		45	Radio wave beacon - no antenna connected
46	Optical beacon - no antenna connected		
47	No FM antenna connected		
4A	FM receiver abnormal		
4B	Radio wave beacon abnormal		
4C	Optical beacon abnormal		
40	Voice control activation SW abnormal		
41	Voice-control Microphone abnormal		
40	Multi-CD-CH (optical cable) abnormal		
41	Multi-CD-CH (optical cable) not connected		
42	Multi-CD-CH (CarNet) abnormal		
43	Multi-CD-CH (CarNet) not connected		
50	HT64 communication not connected		
51	HT64 communication abnormal		
52	HT64 BRQ disconnection		
53	HT64 BRQ short-circuit		
54	HT64 disconnection		
55	CarNet communication not connected		
56	CarNet communication abnormal		
57	CarNet periodical communication abnormal		
10	Video circuit abnormal		
11	Back light abnormal (with no current)		
12	Back light abnormal (with excessive current)		
13	Panel open/close mechanical operation abnormal		
40	Front seat monitor abnormal		
41	Heater abnormal		
10	Panel SW abnormal		
23H	Touch SW failure		
24H	Command		
25H	SW		
11	PLL Unlock		
12	CODEC Communication Error		
13	SSDEC Communication Error		
14	SSDEC No Response Error		
15	NVM Error		
16	CAP Error		
40	ANTENNA No Contact		
41	ANTENNA Short		

Diagnosis code table

Logical address name	Logical address	Diagnosis code	Diagnosis details		
XM	COH	11	PLL unlocked		
		12	CDEC communication error		
		13	SSDEC communication error		
		14	SSDEC no response		
		15	NVM error		
		16	CAP error		
		40	No antenna connected		
		41	Antenna short-circuited		
		DVD-CH	45H	42	Disc unreadable
				44	DVD abnormal
				45	EJECT abnormal
				46	Scratches or non-recorded side
				47	DVD high temperature detected
				48	Excessive current detected
				50	Trey IN/OUT abnormal
				51	Elevator abnormal

A

B

C

D

E

F

TEL 13942296513 QQ 376315150 892498299

TEL 13942296513 QQ 376315150 892498299

www.xiaoyu163.com

www.xiaoyu163.com

www.xiaoyu163.com

www.xiaoyu163.com

TEL 13942296513 QQ 376315150 892498299

7. GENERAL INFORMATION

7.1 DIAGNOSIS

7.1.1 DISASSEMBLY

● Removing the Upper Case (not shown)

1. Remove the Case.

● Removing the Cassette Mechanism Module (Fig.1)

1 Remove the four screws and then remove the Cassette Mechanism Module.

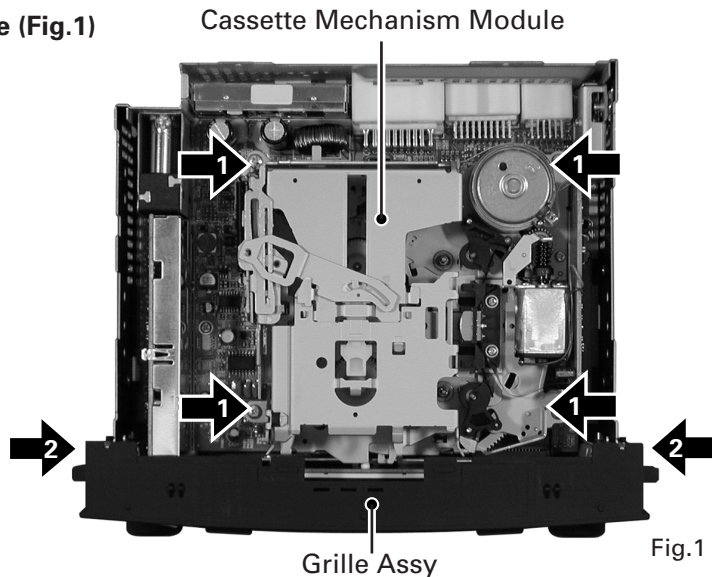

● Removing the Grille Assy (Fig.1)

2 Remove the two screws and then remove the Grille Assy.

● Removing the Front Frame (Fig.2)

1 Remove the three screws and then remove the Front Frame.

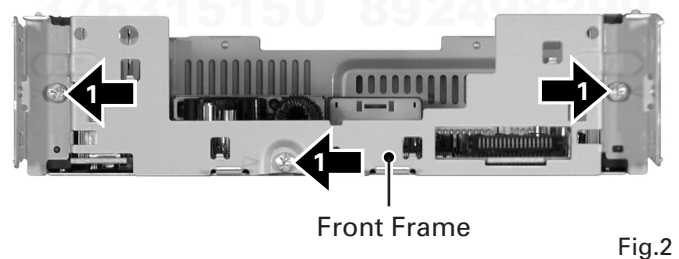

● Removing the Main Unit (Fig.3)

1 Straighten the tabs at two locations indicated.

2 Remove the two screws.

3 Remove the two screws and then remove the Main Unit.

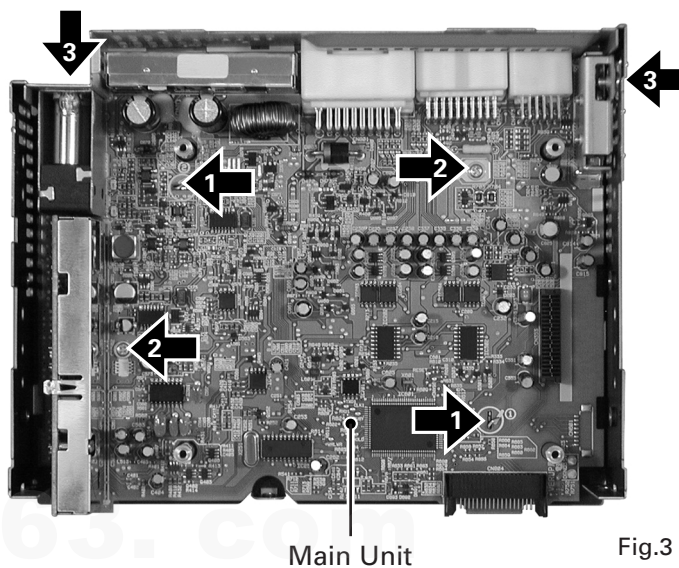

7.1.2 CONNECTOR FUNCTION DESCRIPTION

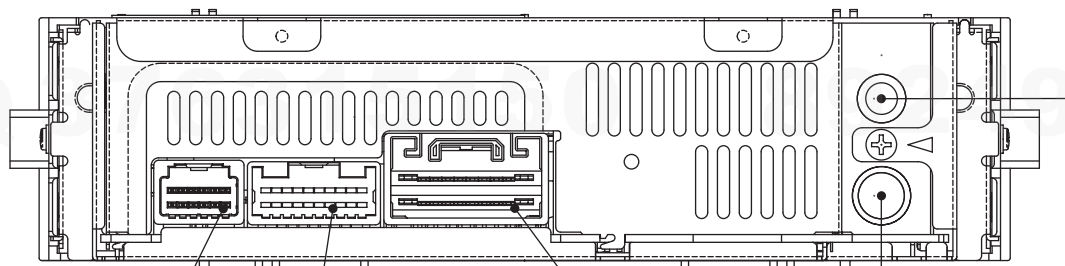

SUB ANTENNA

MAIN ANTENNA

MUTE	L-	L+	R-	R+	SGND
(BU)	(ACC)	TX-	TX+	NC	(GND)

(SLD)	L+	R+	MUTE	NC	TX+	NC	(AMP-B)	ILL+	BU
GND	L-	R-	NC	NC	TX-	NC	ANT-B	ILL-	ACC

TX-	TX+	SW2	SW1	SWG	CMP-	CMP+	NC	NC	NC
NC	RMU	RSL-	RSL+	RSR-	RSR+	(SLD)	NC	NC	NC

A
B
C
D
E
F

7.1.3 TROUBLE-SHOOTING

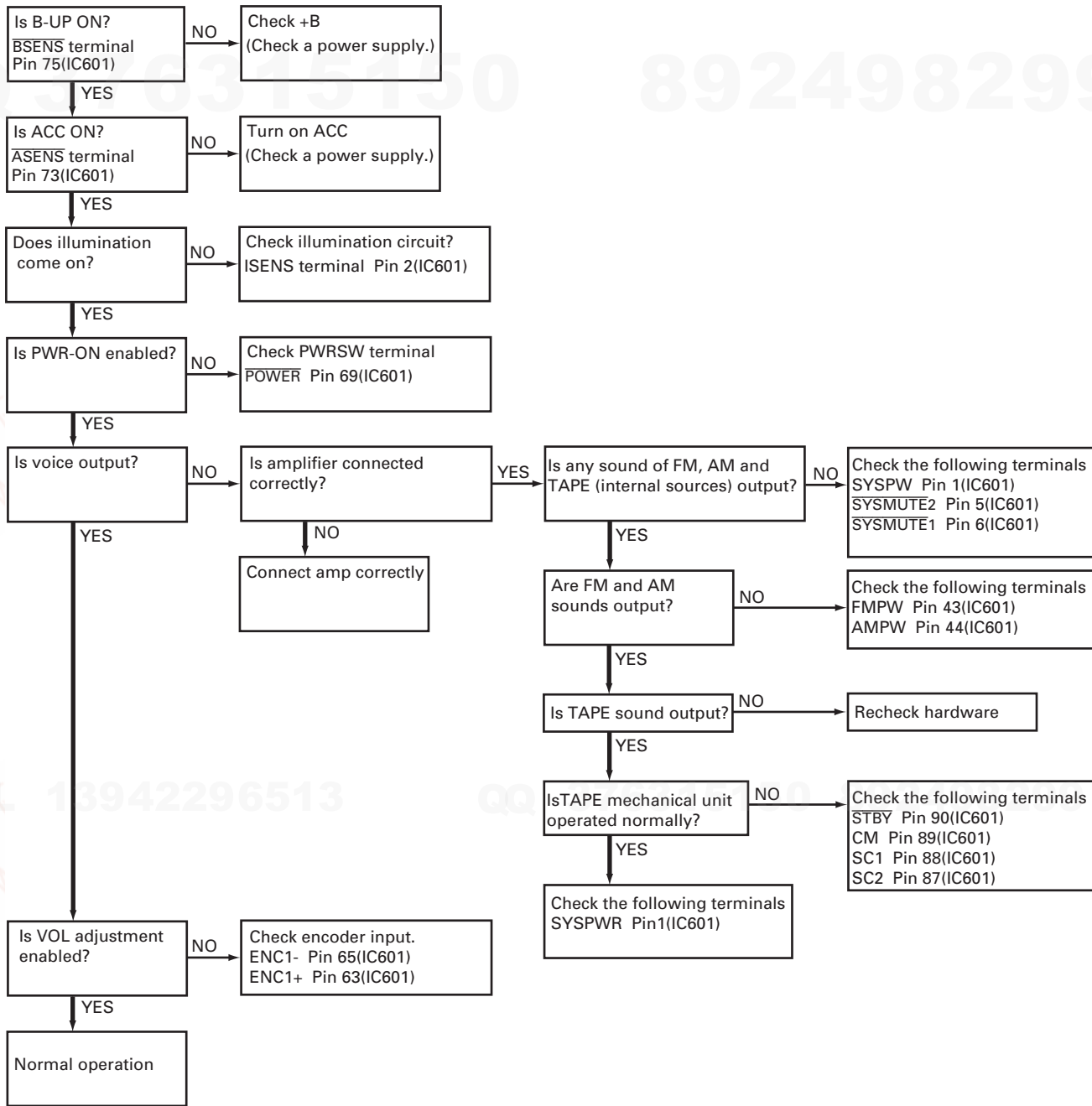

TEL 13942296513 QQ 376315150 892498299

"无奇不有" 电路板
www.xiaoyu163.com

"无奇不有" 电路板
www.xiaoyu163.com

"无奇不有" 电路板
www.xiaoyu163.com

7.2 IC

● Pin Functions(PD5945A)

Pin No.	Pin Name	I/O	Function and Operation
1	SYSPWR	O	Power supply control output
2	ISENS	I	Illumination sense input
3	KISYU	I	Model input
4	LAMP	O	Lamp power supply control(D/A) output
5	SYSMUTE2	O	System mute output for RSE
6	SYSMUTE	O	System mute output
7	RSEMUTE	O	RSE mute output
8	BYTE	I	Vss(Single chip) input
9	CNVSS	I	CNVSS input
10	LANMUTE	O	AVC-LAN mute output
11	SWVDD	O	SWVDD output
12	RESET	I	Reset input
13	XOUT	O	Main clock output
14	VSS	I	GND input
15	XIN	I	Main clock input
16	VCC	I	Power supply(2.7-5.5V) input
17	NMI	I	VDD input
18	RCK	I	RDS data clock input
19	LDET	I	PLL lock signal input
20	NC	O	Not used
21	RX2	I	(BUS)
22	IPPW	O	BUS power supply output
23	SEL2a	O	Selector switch a output for RSE
24	NC	O	Not used
25	SEL2b	O	Selector switch b output for RSE
26	SHIMUKE	I	Model input(L, R)
27	SEL1a	O	Selector switch a output for AMP
28	SEL1b	O	Selector switch b output for AMP
29	RX1	I	(BUS)
30	TX	O	(BUS)
31	PDO	O	PLL data output
32	PDI	I	PLL data input
33	PCK	O	PLL data clock output
34	NC	O	Not used
35	SPDO	O	Sub tuner data output
36	SPDI	I	Sub tuner data input
37	SPCK	O	Sub tuner data clock output
38	SCE	O	Sub tuner chip enable output
39	SCPON	O	Sub tuner power supply control output
40	SSD	I	Sub tuner station ON signal input
41, 42	NC	O	Not used
43	FMPW	O	FM power output
44	AMPW	O	AM power output
45	RDSMUTE	O	RDS mute output
46	DRST	O	RDS decoder IC reset output
47	CURRO	O	Current request output
48	RDS57K	I	RDS 57kHz ON/OFF input
49	RDT	I	RDS data input
50	RDSLK	I	RDS station ON signal input
51	LOCL	O	Local L output
52, 53	PCE1, 2	O	PLL chip enable 1, 2 output
54	SDBW	I	SD bandwidth ON signal input
55	NL2	I	NL2 ON signal input
56	FMSD	I	FM ON signal input
57	ST	I	Stereo input

Pin No.	Pin Name	I/O	Function and Operation
58	ROMDT	O	ROM correction data output
59	ROMCLK	O	ROM correction clock output
60	ROMCS	O	ROM correction chip select output
61	TEST	I	Test mode input
62	VCC	I	Power supply(2.7-5.5V) input
63	ENC1+	I	VOL encoder input +
64	VSS	I	GND input
65	ENC1-	I	VOL encoder input -
66-68	KST0-2	O	Key strobe output 0-2
69	POWER	I	POWER key input
70-72	KDT0-2	I	Key data input 0-2
73	ASENS	I	ACC sense input
74	CSEJ	I	Tape eject sense input
75	BSENS	I	Back up sense input
76	KDT3	I	Key data input 3
77	ENC2+	I	AUD encoder input +
78	ENC2-	I	AUD encoder input -
79	MS	I	Music sense input
80	F/R	O	Head forward/reverse select output
81	PLAY	O	MS gain select output
82	MTL	I	METAL input
83	NR	O	Dolby B NR ON/OFF output
84	CSLOAD	I	Tape loading detect input
85	POS	I	Position sense input
86	ES	I	Tape end detect input
87, 88	SC2, 1	O	Sub motor control output 2, 1
89	CM	O	Capstan control output
90	STBY	O	Tape stand-by output
91	NL1	I	Noise level input
92	SSL	I	Sub tuner signal level input
93	MSL	I	Main tuner signal level input
94	ILL-	I	Illumination - input
95	STSW2	I	Steering SW 2 input
96	AVSS	I	A/D converter GND input
97	STSW1	I	Steering SW 1 input
98	VREF	I	A/D converter reference voltage input
99	AVCC	I	A/D converter power supply input
100	ANTB	O	Antenna power supply control output

* PD5945A

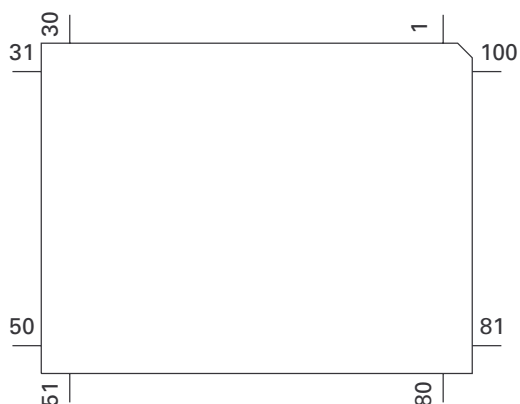

IC's marked by * are MOS type.

Be careful in handling them because they are very liable to be damaged by electrostatic induction.

● FM/AM Tuner Unit

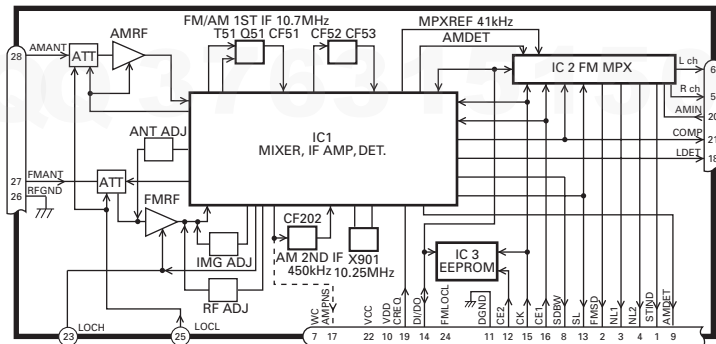

No.	Symbol	I/O	Explain	
1	STIND	O	stereo indicator	"Low" when the FM stereo signals are received. To be pulled up to the "VDD" at 47kΩ.
2	FMSD	O	FM station detector	"High" when signals are received. To be pulled up to the "VDD" at 47kΩ. Meanwhile, 10kΩ should be used when taking diver FIX trigger from here and "High: 0.9VDD or more" and "Low: 250mV or less". (Should satisfy the diver IC specifications)
3	NL1	O	noise level-1	"High" when noise is received. Output for the RDS. GND at 47kΩ//1,800pF.
4	NL2	O	noise level-2	"High" when noise is received. Output for the RDS. GND at 36kΩ//330pF.
5	Rch	O	R channel output	FM stereo "R-ch" signal output or AM audio output. Add the specified de-emphasis constant.
6	Lch	O	L channel output	FM stereo "L-ch" signal output or AM audio output. Add the specified de-emphasis constant.
7	WC		write control	EEPROM write control. Writing permissible at "Low". Normally open.
8	SDBW	O	SD bandwidth	SD bandwidth signal output. For detection of detuning data for the RDS.
9	AMDET	O	AM detector output	AM detector output. r out < 100Ω
10	VDD		power supply	Power supply pin for the digital section. DC 5V +/- 0.25V. Be careful about overlapping noise in the logic section.
11	DGND		digital ground	Grounding for the digital section.
12	CE2	I	chip enable-2	EEPROM chip enable. Active a "Low". To be pulled up to the "VDD" at 47kΩ
13	SL	I/O	signal level	Received FM/AM signal level (strength) output. Connect the specified load resistor and capacitor (10k Ω+ 39k Ω//4,700pF)
14	DI/DO	I/O	data input/ data output	Data input/Data output. To be pulled up to the "VDD" at 47kΩ
15	CK	I	clock	Clock input. To be pulled up to the "VDD" at 47kΩ
16	CE1	I	chip enable-1	AF-RF chip enable. Active at "High". To be grounded at 47kΩ
17	AMPNS	O	AM PNS IF signal	IF signal output for AM PNS circuit.
18	LDET	O	lock detector	Active at "Low". To be pulled up to the "VDD" at 47kΩ
19	CREQ	I	current request	Active at "Low". To be grounded at 47kΩ
20	AMINI		AM audio input	The frequency response and the level are set by connecting an external CR network with terminal AMIN as terminal AMDET. r in = 50kΩ
21	COMP	O	composite signal	FM composite signal output. r out < 100Ω
22	VCC		power supply	Analog section power supply pin. DC 8.4V +/- 0.3V
23	LOCH	I	local high	FM local high pin. When seeking local high, apply 5V together with "LOCL".
24	FMLOCL	I	FM local low	FM local low pin. When seeking local low, apply 5V to the base of the NPN transistor with which the specified resistor is being connected to the emitter. Keep it open in case of ordinary marketed models.
25	LOCL	I	local low	FM/AM local low pin. When seeking local low, apply 5V to the base of the NPN transistor. Since this pin is exclusive for AM when the FMLOCL is in use, do not drive it under FM.
26	RFGND		RF ground	Grounding for the antenna section.
27	FMANT	I	FM antenna input	FM antenna input. 75Ω. Surge absorber (DSP-201M-S00B) is necessary.
28	AMANT	I	AM antenna input	AM antenna input. High impedance. Connect to the antenna through an L (LAU type) of 4.7μH. To cope with the power transmission line hums, insert a series circuit consisting of an L (a coil of about 100mH) + R (a resistor of 470 Ω to 2.2kΩ) between the GND.

5
6
7
8

7.3 EXPLANATION

7.3.1 SYSTEM BLOCK DIAGRAM

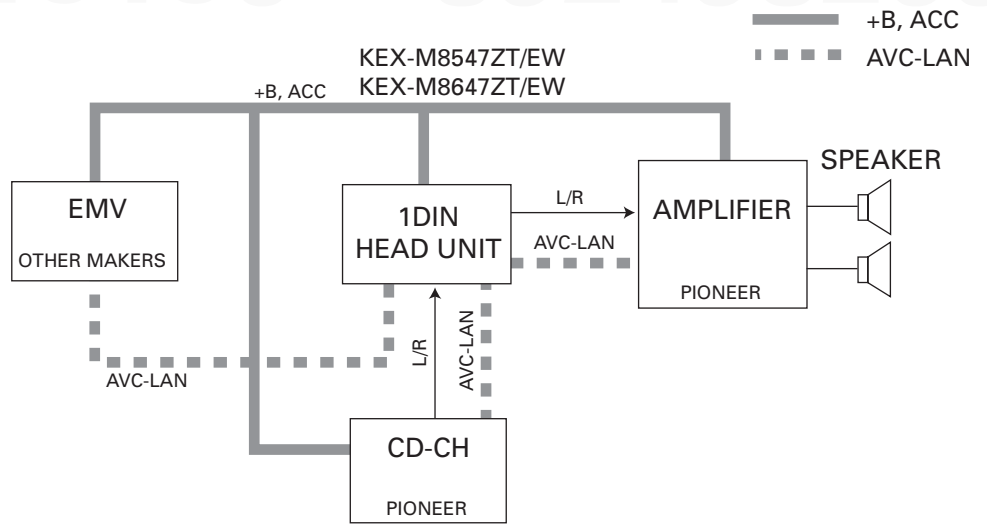

7.3.2 OPERATIONAL FLOW CHART

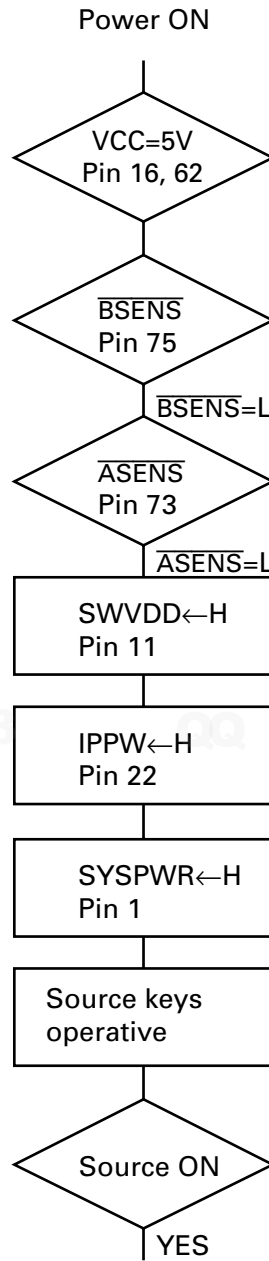

Completes power-on operation.
(After that, proceed to each source operation)

7.4 CLEANING



Before shipping out the product, be sure to clean the following portions by using the prescribed cleaning tools:

Portions to be cleaned	Cleaning tools
Cassette heads Pinch rollers Capstans	Cleaning paper : GED-008

TEL 13942296513 QQ 376315150 892498299

"无奇不有" 电路图网
www.xiaoyu163.com

"无奇不有" 电路图网
www.xiaoyu163.com

"无奇不有" 电路图网
www.xiaoyu163.com

"无奇不有" 电路图网
www.xiaoyu163.com

"无奇不有" 电路图网
www.xiaoyu163.com

"无奇不有" 电路图网
www.xiaoyu163.com

"无奇不有" 电路图网
www.xiaoyu163.com

"无奇不有" 电路图网
www.xiaoyu163.com

"无奇不有" 电路图网
www.xiaoyu163.com

8. OPERATIONS

A
B
C
D
E
F

- KEX-M8547ZT/EW
- RADIO

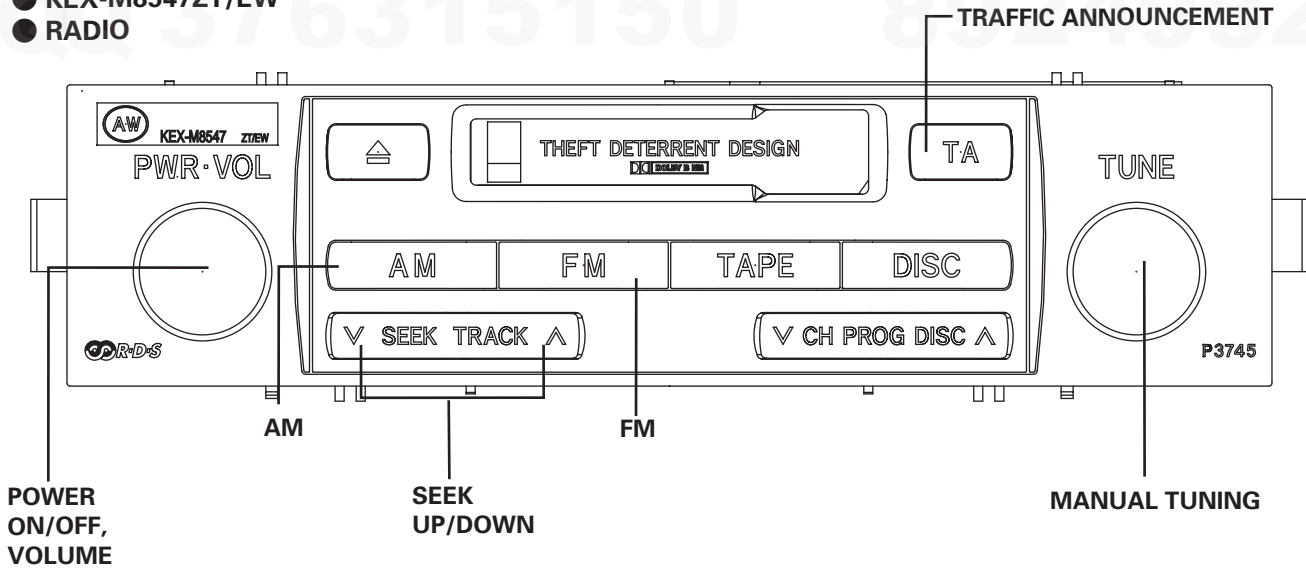

- TAPE

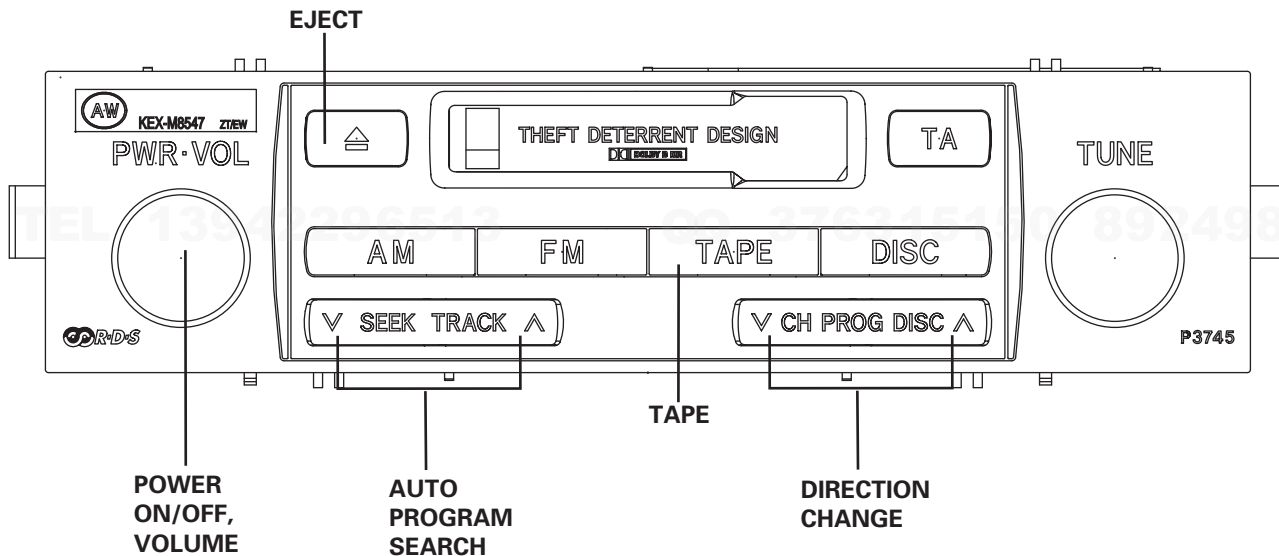

- CD, DVD

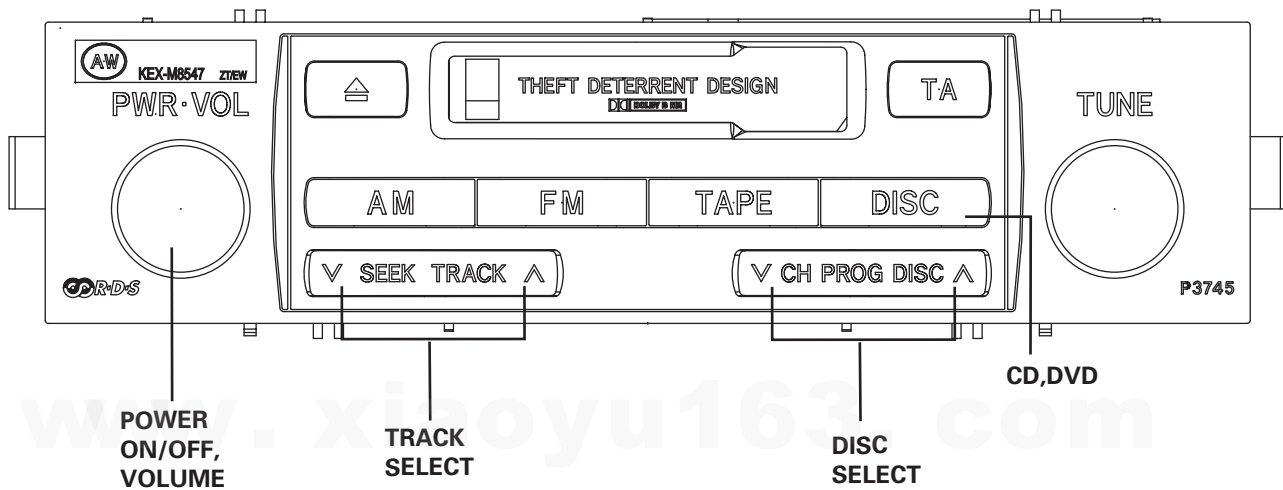

● KEX-M8647ZT/EW
● RADIO

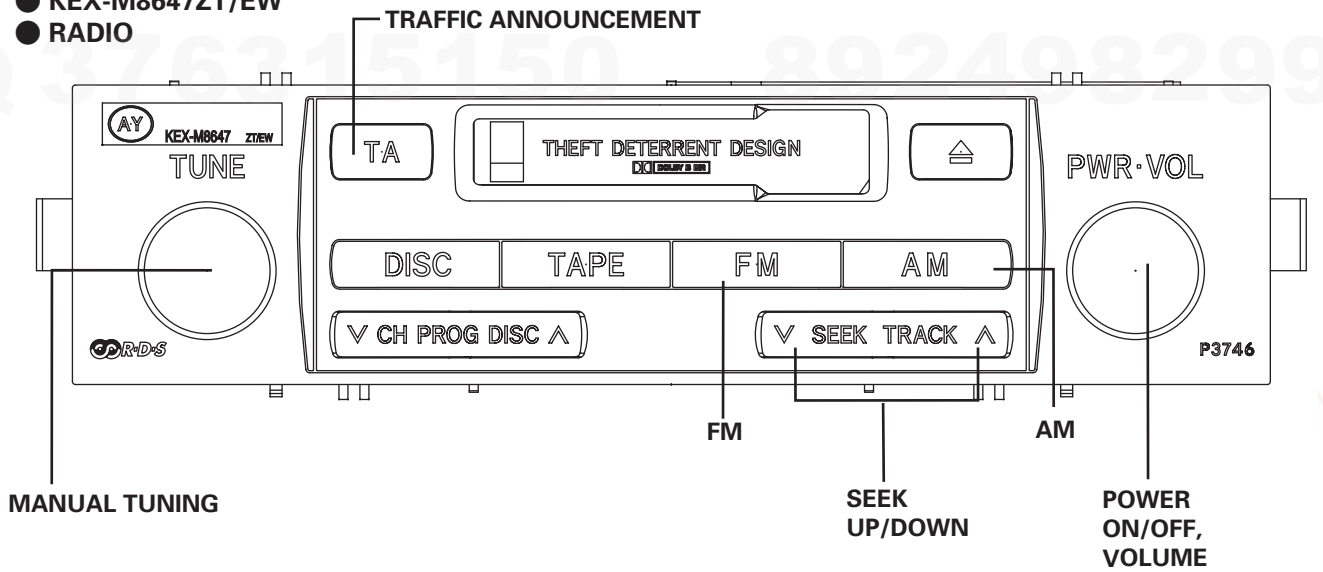

● TAPE

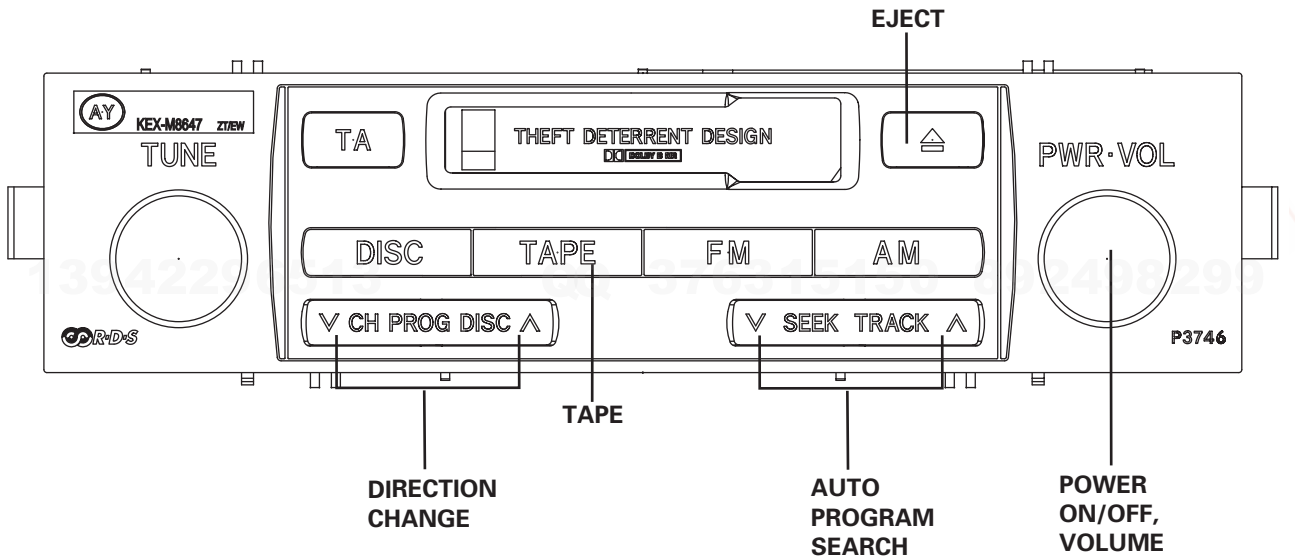

● CD, DVD

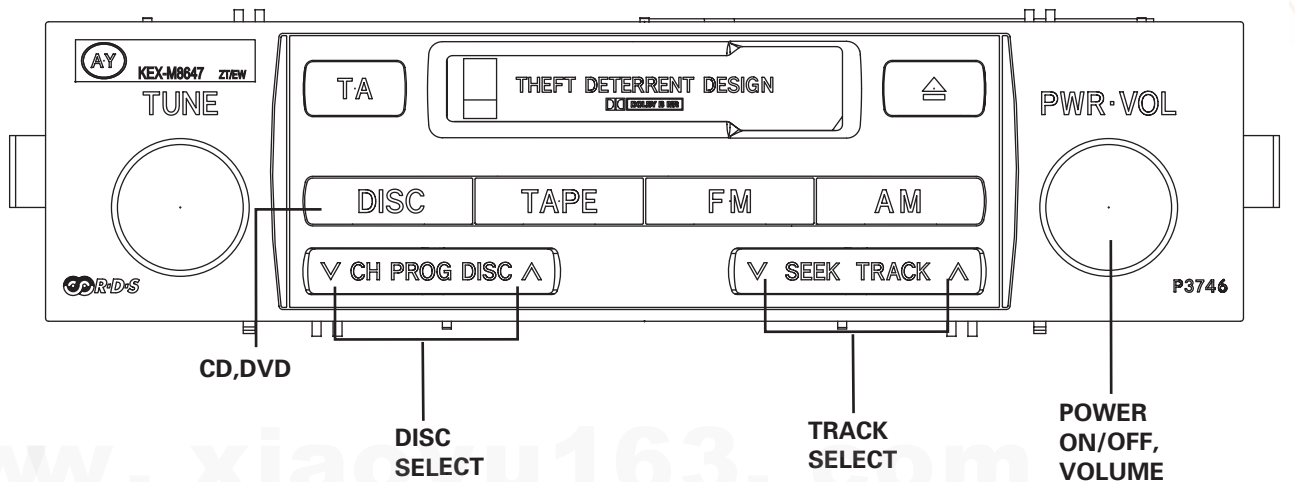

● Jigs List

Name	Jig No.	Remarks
Extension cord	GGD1169	Adjustment
Extension cord	GGD1240	Adjustment
Extension cord	GGD1304	Adjustment
Extension cord	GGD1346	Adjustment
Extension cord	GGD1121	Cassette mechanism module adjustment
Test tape	NCT-150	Cassette mechanism module adjustment
Cleaning paper	GED-008	Cleaning cassette heads, pinch rollers and capstans

A

B

C

D

E

F