

Thick film thermal printhead (with thermal historical control)

KF2006-GM50A

GM50 series is the new product that newly added the future history control and driver LSI which has the function of thermal historical control, to GL50 series which is employing the conventional thick-film fast response thermal element.

●Applications

High speed label printer
High speed bar code printer
High speed ticket printer
Various high speed terminal printers

●Features

- 1) Newly developed thick-film fast response thermal element and driver LSI with the function of thermal history control which is added the future history control are employed for this series. It is possible to print with super high speed of 10 inches / s or 250 mm / s.
- 2) 150km life realized by attributing durable new protection film.
- 3) New partial glaze construction makes it compatible with the thermal transfer application.
- 4) Market-proven G-series printhead construction ensures high reliability.

Printhead

●External dimensions (Units : mm)

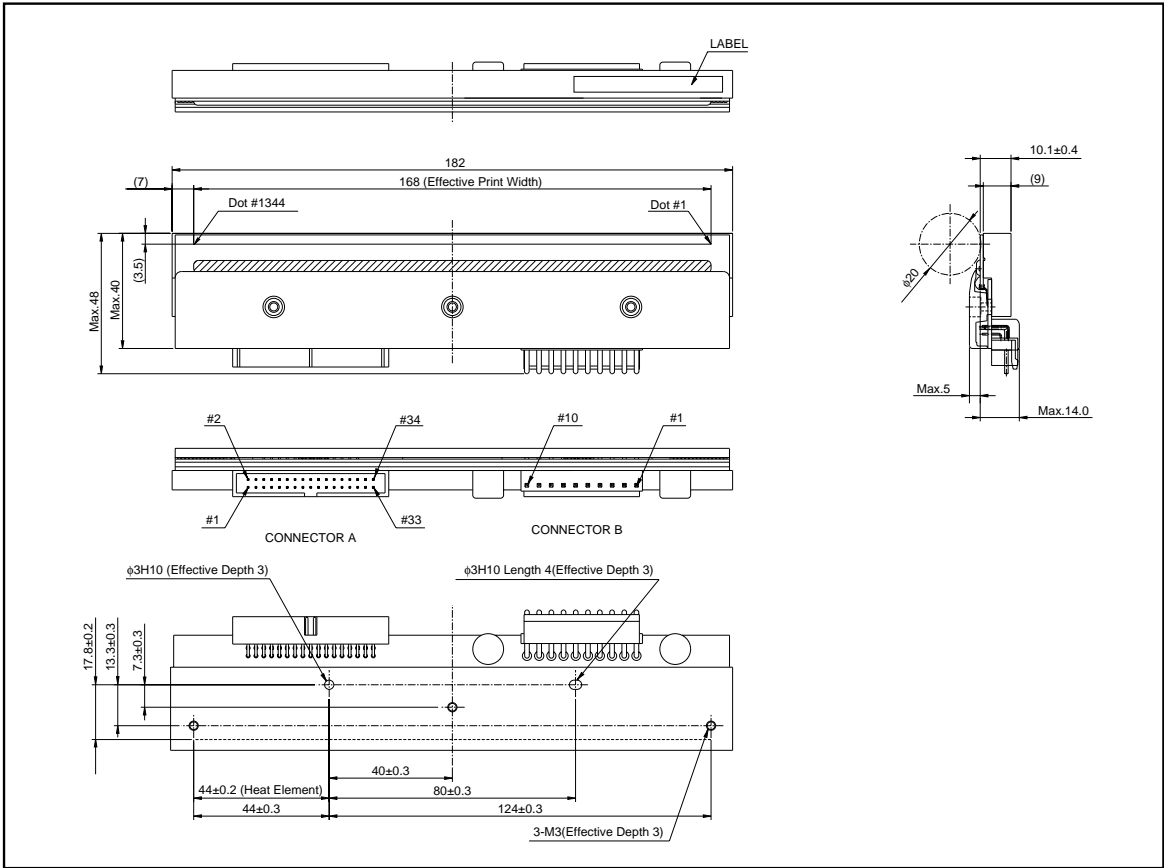

Printhead

●Equivalent circuit

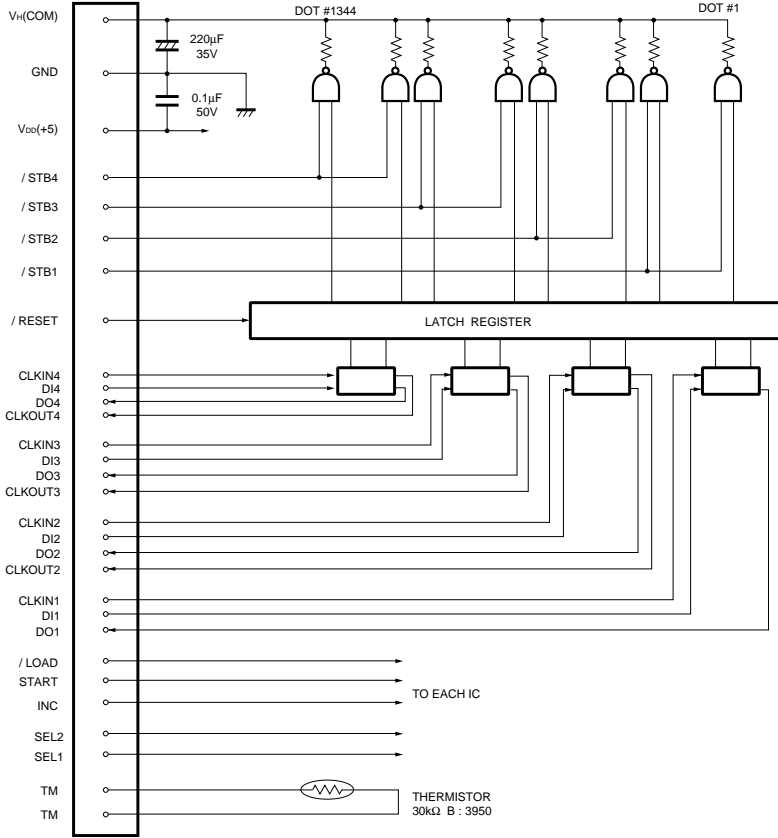

DI,STB DIVISION DOT No. CORRESPONDENCE

DI No.	DOT No.	/ STB No.	DOT No.	CLK No.	DOT No.
DI4	1344~961	/ STB4	1344~961	CLKIN2	1344~961
DI3	960~705	/ STB3	960~705	CLKIN1	960~705
DI2	704~321	/ STB2	704~321	CLKIN2	704~321
DI1	320~ 1	/ STB1	320~ 1	CLKIN1	320~ 1

Fig.1

Printhead

●Pin assignments

CONNECTOR A				CONNECTOR B	
No.	Circuit	No.	Circuit	No.	Circuit
1	V _{DD}	18	/ LOAD	1	V _H (COM)
2	V _{DD}	19	/ RESET	2	V _H (COM)
3	NC	20	START	3	V _H (COM)
4	NC	21	TM	4	V _H (COM)
5	SEL2	22	TM	5	V _H (COM)
6	SEL1	23	DI2	6	GND
7	CLKIN4 (CP)	24	DO2	7	GND
8	CLKOUT4	25	DI1	8	GND
9	CLKIN3	26	DO1	9	GND
10	CLKOUT3	27	/ STB2	10	GND
11	DI4	28	/ STB1		
12	DO4	29	CLKIN2		
13	DI3	30	CLKOUT2		
14	DO3	31	CLKIN1		
15	/ STB4	32	NC		
16	/ STB3	33	NC		
17	INC	34	NC		

●Characteristics

Parameter	Symbol	Typical	Unit
Effective printing width	–	168	mm
Dot pitch	–	0.125	mm
Total dot number	–	1344	dots
Average resistance value	R _{ave}	650	Ω
Applied voltage	V _H	24	V
Applied power	P _o	0.727	W/dot
Print cycle	SLT	0.49	ms
Pulse width	T _{ON}	0.337	ms
Maximum number of dots energized simultaneously	–	1344	dots
Maximum clock frequency	–	8	MHz
Maximum roller diameter	–	φ20.0	mm
Running life / pulse life	–	150/(1×10 ⁸)	km/pulses
Operating temperature	–	5~45	°C

Printhead

●Data sheets

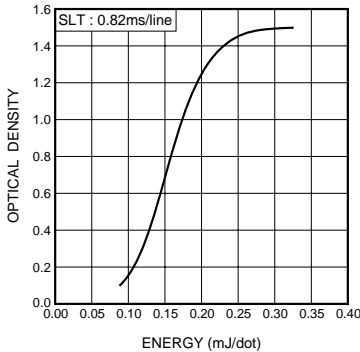

Fig.2 Representative density curve

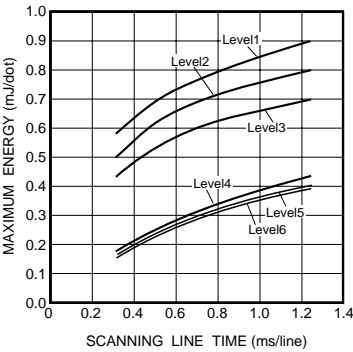

Fig.3 Maximum energy curve

