

RF Duplexer for Cordless phone (CIS)

- High stability and reliability with good performance and no adjustment.
- Wide and sharp pass band characteristics.
- Low insertion loss and deep stop band attenuation for interference.

MAXIMUM RATINGS (Ta=25°C)

ITEM	SYMBOL	RATING	UNIT
Input Signal Level	IS _{max}	17	dBm
DC Permissive Voltage	V _{DC}	3	V
Operating Temperature Range	T _{opr}	0~+60	°C
Storage Temperature Range	T _{stg}	-40~+85	°C

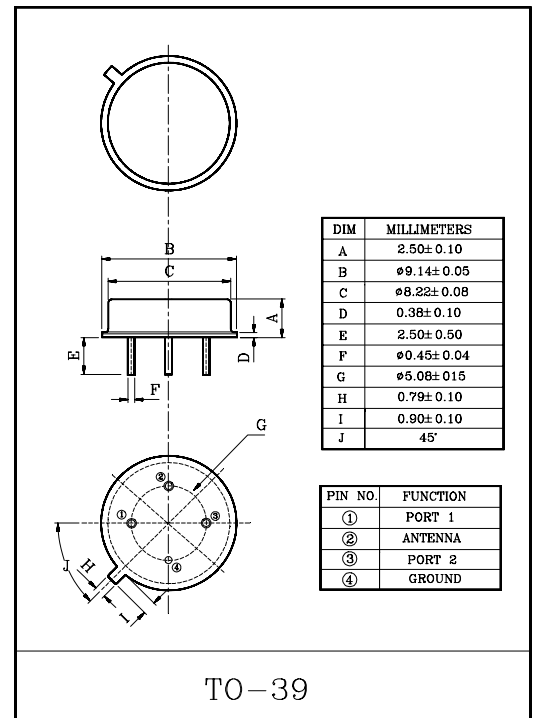

ELECTRICAL CHARACTERISTICS (Temperature 25±2°C, Humidity 65±5%)

ITEMS	SYMBOL	PORT 1				PORT 2				UNIT
		TEST CONDITION	MIN.	TYP.	MAX.	TEST CONDITION	MIN.	TYP.	MAX.	
Center Frequency	f ₀	-	-	904.5	-	-	-	814.5	-	MHz
Bandwidth	BW _{3dB}	-	f ₀ ±0.5	-	-	-	f ₀ ±0.5	-	-	MHz
Insertion Loss	IL _{PASS}	f ₀ ±0.5MHz	-	-	4.0	f ₀ ±0.5MHz	-	-	4.0	dB
Ripple Level	A _{RIP}	f ₀ ±0.5MHz	-	-	1.5	f ₀ ±0.5MHz	-	-	1.5	dB
Rejection Level	IL _{STOP}	450.00~795.00MHz	45	-	-	450.00~749.50MHz	45	-	-	dB
		795.00~861.70MHz	37	-	-	749.50~771.70MHz	41	-	-	dB
		861.70~883.10MHz	30	-	-	771.70~793.10MHz	28	-	-	dB
		883.10~893.80MHz	5	-	-	793.10~800.80MHz	5	-	-	dB
		914.2~917.30MHz	8	-	-	824.20~828.00MHz	11	-	-	dB
		917.30~924.90MHz	17	-	-	828.00~834.90MHz	20	-	-	dB
		924.90~925.90MHz	32	-	-	834.90~835.90MHz	32	-	-	dB
		925.90~946.30MHz	26	-	-	835.90~856.30MHz	27	-	-	dB
		946.30~947.30MHz	28	-	-	856.30~858.50MHz	32	-	-	dB
		959.50~994.50MHz	40	-	-	858.50~1000.00MHz	37	-	-	dB
		994.50~1350.00MHz	45	-	-	1000.00~1350.00MHz	42	-	-	dB
1350.00~1800.00MHz	32	-	-	1350.00~1800.00MHz	32	-	-	dB		
Input/Output Impedance	Z _I (Z _O)	-	-	50Ω	-	-	50Ω	-	-	

KFX0414T

MEASUREMENT CIRCUIT

(1) BETWEEN PORT1 AND ANTENNA

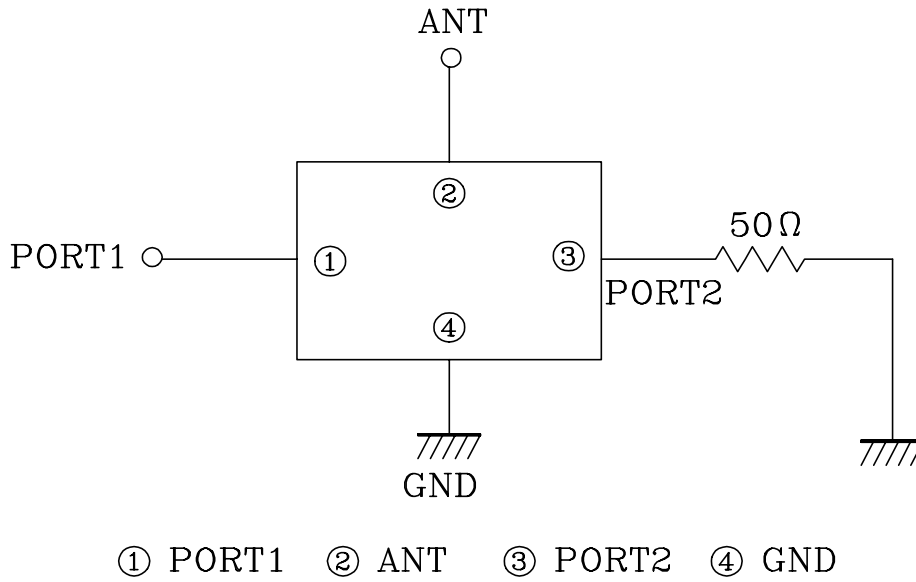

(2) BETWEEN PORT2 AND ANTENNA

