

RF Duplexer for Cordless phone (CIS)

- High stability and reliability with good performance and no adjustment.
- Wide and sharp pass band characteristics.
- Low insertion loss and deep stop band attenuation for interference.

MAXIMUM RATINGS (T_a=25°C)

ITEM	SYMBOL	RATING	UNIT
Input Signal Level	I _{Smax}	17	dBm
DC Permissive Voltage	V _{DC}	3	V
Operating Temperature Range	T _{opr}	0~+60	°C
Storage Temperature Range	T _{stg}	-40~+85	°C

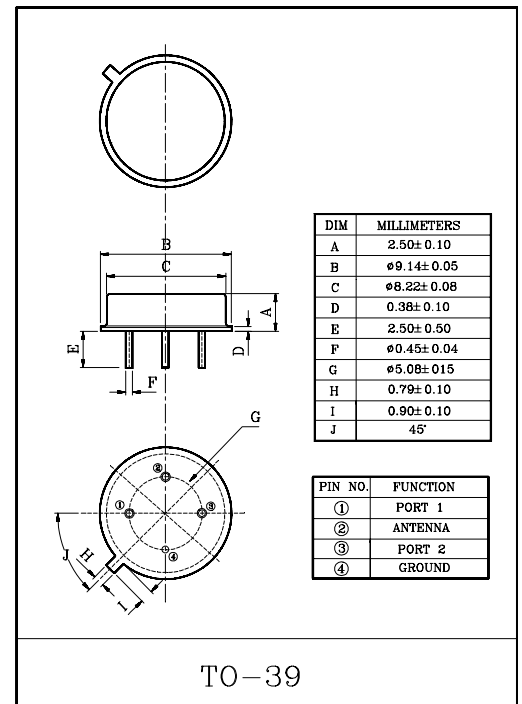

ELECTRICAL CHARACTERISTICS (Temperature 25±2°C, Humidity65±5%)

ITEMS	SYMBOL	PORT 1				PORT 2				UNIT
		TEST CONDITION	MIN.	TYP.	MAX.	TEST CONDITION	MIN.	TYP.	MAX.	
Center Frequency	f _o	-	-	814.5	-	-	904.5	-	MHz	
Bandwidth	BW _{3dB}	-	f _o ±0.5	-	-	-	f _o ±0.5	-	MHz	
Insertion Loss	IL _{PASS}	f _o ±0.5MHz	-	-	4.0	f _o ±0.5MHz	-	-	4.0	dB
Ripple Level	A _{RIP}	f _o ±0.5MHz	-	-	1.5	f _o ±0.5MHz	-	-	1.5	dB
Rejection Level	IL _{STOP}	450.00~749.50MHz	45	-	-	450.00~795.00MHz	45	-	-	dB
		749.50~771.70MHz	40	-	-	795.00~861.70MHz	37	-	-	dB
		771.70~793.10MHz	28	-	-	861.70~883.10MHz	30	-	-	dB
		793.10~800.80MHz	6	-	-	883.10~893.80MHz	5	-	-	dB
		824.20~828.00MHz	12	-	-	914.2~918.50MHz	8	-	-	dB
		828.00~834.90MHz	20	-	-	918.50~924.90MHz	17	-	-	dB
		834.90~835.90MHz	32	-	-	924.90~925.90MHz	32	-	-	dB
		835.90~856.30MHz	26	-	-	925.90~946.30MHz	23	-	-	dB
		856.30~858.50MHz	32	-	-	946.30~947.30MHz	28	-	-	dB
		858.50~1000.00MHz	37	-	-	959.50~994.50MHz	40	-	-	dB
		1000.00~1350.00MHz	42	-	-	994.50~1350.00MHz	45	-	-	dB
1350.00~1800.00MHz	32	-	-	1350.00~1800.00MHz	32	-	-	dB		
Input/Output Impedance	Z _i (Z _o)	-	-	50Ω	-	-	50Ω	-	-	

KFX1404T

MEASUREMENT CIRCUIT

(1) BETWEEN PORT1 AND ANTENNA

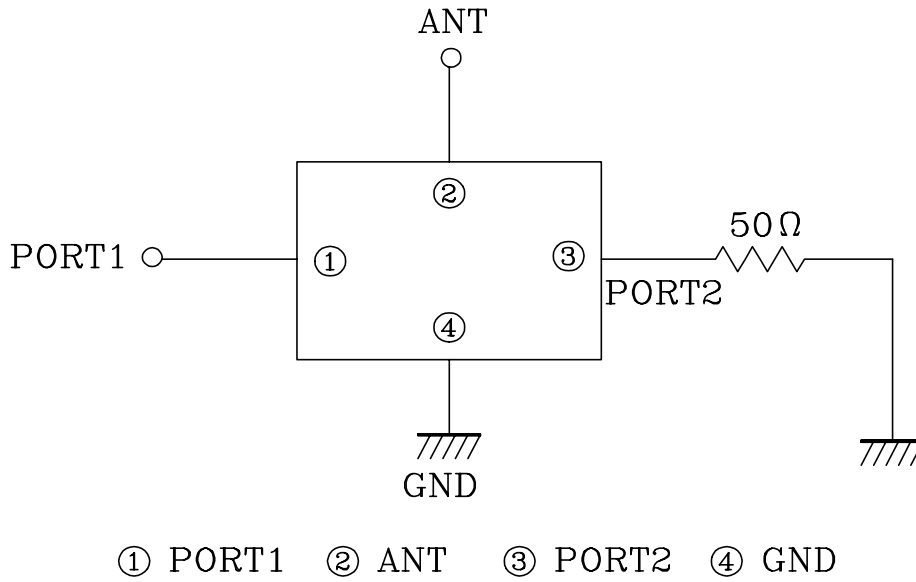

(2) BETWEEN PORT2 AND ANTENNA

