

RF Duplexer for Cordless phone ISM

- High stability and reliability with good performance and no adjustment.
- Wide and sharp pass band characteristics.
- Low insertion loss and deep stop band attenuation for interference.

MAXIMUM RATINGS (T_a=25°C)

ITEM	SYMBOL	RATING	UNIT
Input Signal Level	IS _{max}	5	dBm
DC Permissive Voltage	V _{DC}	0	V
Operating Temperature Range	T _{opr}	0~+55	°C
Storage Temperature Range	T _{stg}	-40~+85	°C

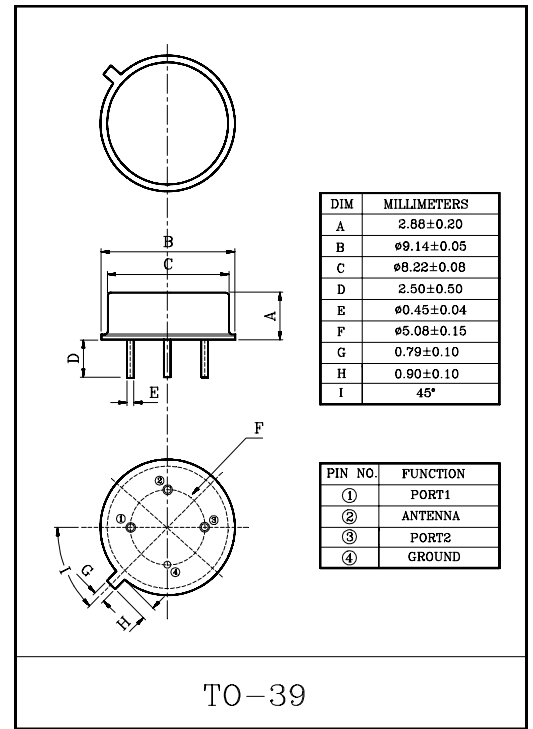

ELECTRICAL CHARACTERISTICS (Temperature 25±2°C, Humidity 65±5%)

ITEMS	SYMBOL	PORT 1				PORT 2				UNIT
		TEST CONDITION	MIN.	TYP.	MAX.	TEST CONDITION	MIN.	TYP.	MAX.	
Center Frequency	f ₀	-	-	926.25	-	-	-	903.75	-	MHz
Bandwidth	BW _{3dB}	-	f ₀ ±1.0	-	-	-	f ₀ ±1.0	-	-	MHz
Insertion Loss	IL _{PASS}	f ₀ ±1.0MHz	-	-	4.5	f ₀ ±1.0MHz	-	-	4.5	dB
Ripple Level	A _{RIP}	f ₀ ±1.0MHz	-	-	2.0	f ₀ ±1.0MHz	-	-	2.0	dB
Rejection Level	IL _{STOP}	450.0~870.0MHz	52	-	-	450.0~861.95MHz	47	-	-	dB
		870.0~882.45MHz	44	-	-	861.95~883.35MHz	30	-	-	dB
		882.45~904.75MHz	30	-	-	883.35~894.05MHz	5	-	-	dB
		904.75~905.85MHz	36	-	-	913.45~924.15MHz	5	-	-	dB
		905.85~916.55MHz	8	-	-	924.15~927.25MHz	38	-	-	dB
		935.95~946.65MHz	5	-	-	945.55~970MHz	23	-	-	dB
		946.65~948.65MHz	30	-	-	970~1050MHz	45	-	-	dB
		968.05~1000MHz	26	-	-	1050~1350MHz	42	-	-	dB
		1000~1350MHz	42	-	-	1350~1800MHz	22	-	-	dB
1350~1800MHz	22	-	-					dB		
Isolation (between port 1 and 2)	IL _{RX→TX}	902.75~924.75MHz	36	-	-	925.25~927.25MHz	36	-	-	dB
Input/Output Impedance	Z _i (Z _o)	-	-	50Ω	-	-	-	50Ω	-	-

KFX2703T

MEASUREMENT CIRCUIT

(1) BETWEEN PORT1 AND ANTENNA

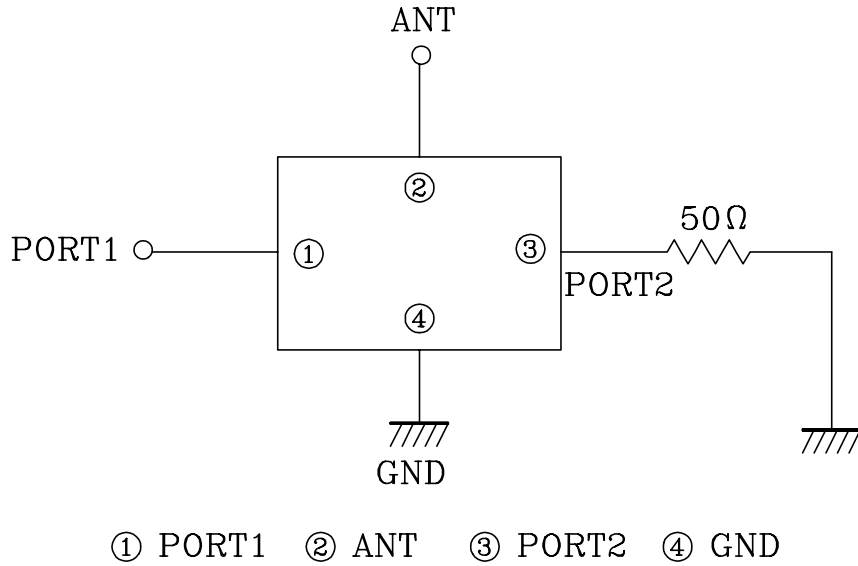

(2) BETWEEN PORT2 AND ANTENNA

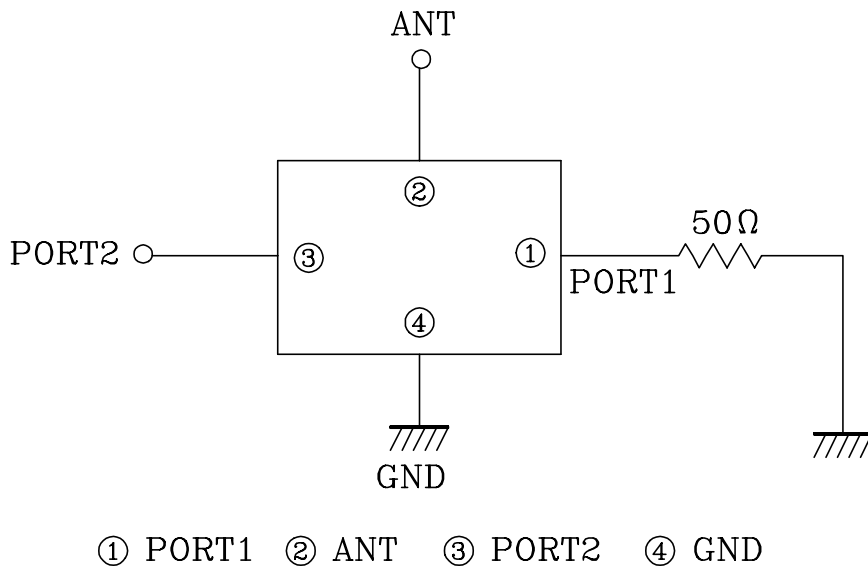

KFX2703T

Frequency - Attenuation (Port 1)

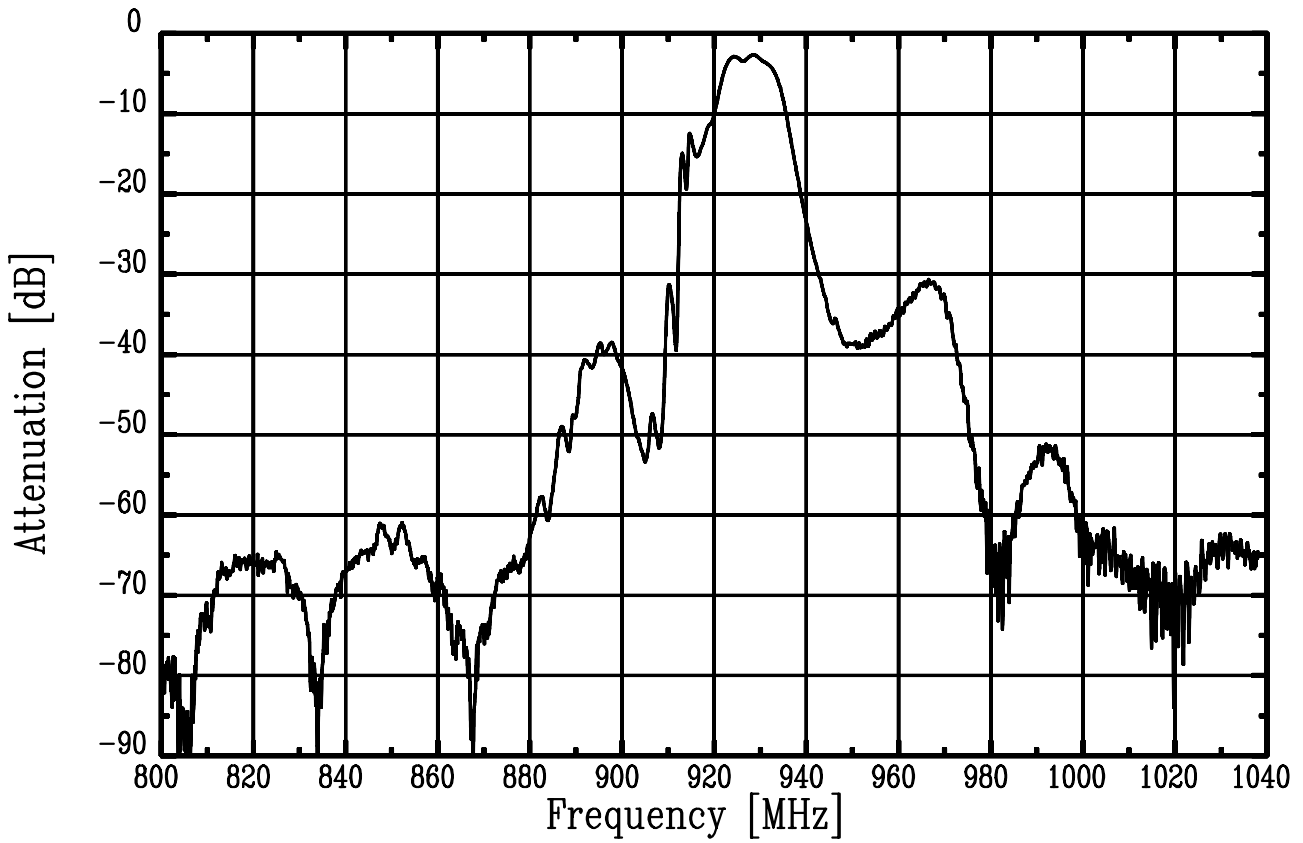

Frequency - Attenuation (Port 2)

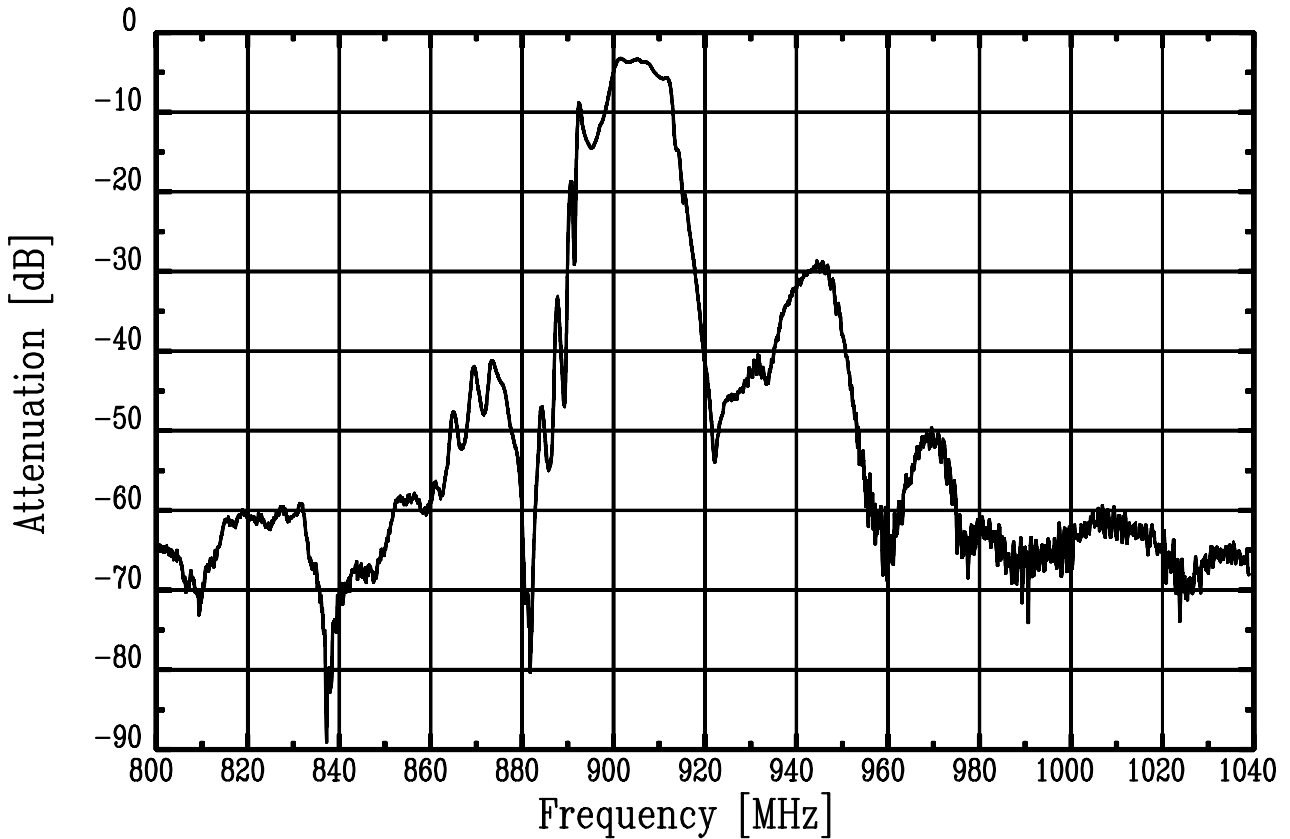

KFX2703T

Frequency - Attenuation (Port 1: Wideband)

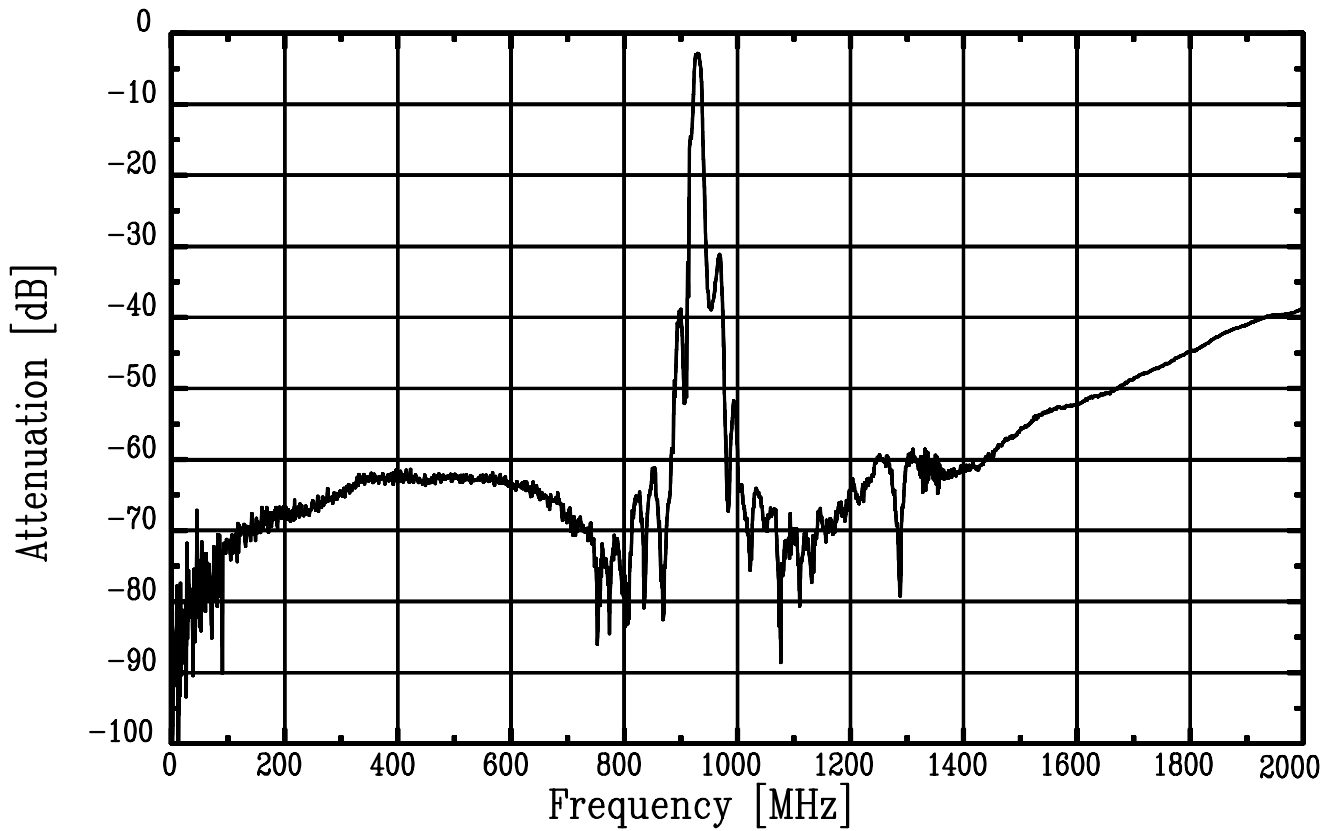

Frequency - Attenuation (Port 2: Wideband)

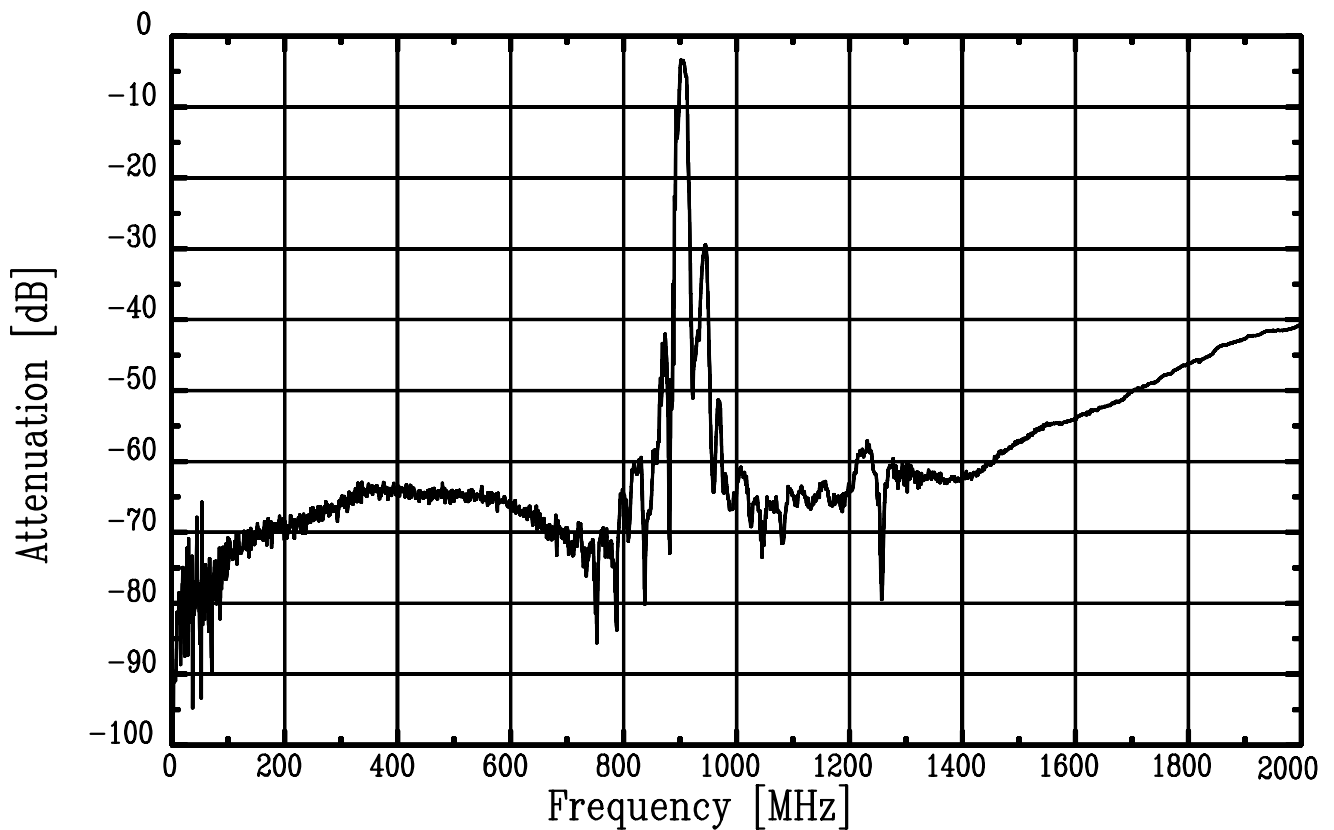

KFX2703T

Isolation between Port 1 and 2

