

General Description

KEC NPT Trench IGBTs offer low switching losses, high energy efficiency and high avalanche ruggedness as well as short circuit ruggedness. It is designed for hard switching applications.

FEATURES

- High speed switching
- High system efficiency
- Short Circuit Withstand Times 5us(@T_C=100)
- Extremely enhanced avalanche capability

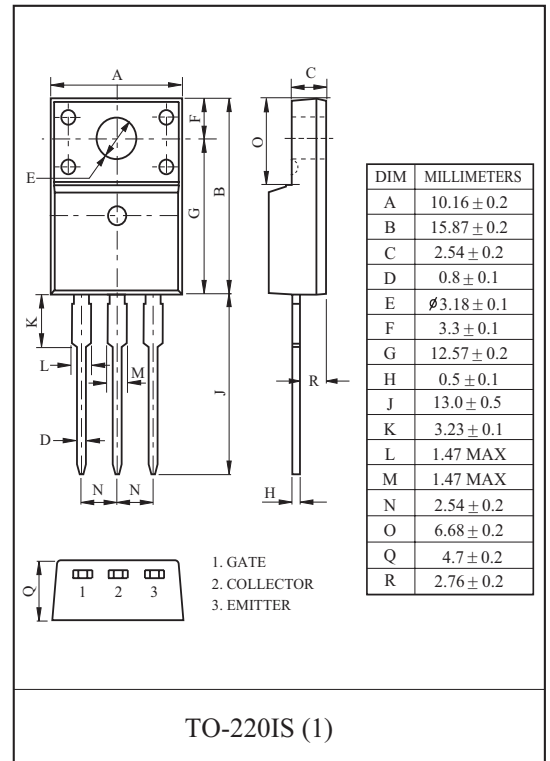

MAXIMUM RATING (Ta=25)

CHARACTERISTIC	SYMBOL	RATING		UNIT
		TO-220IS(1)	TO-220AB	
Collector-Emitter Voltage	V _{CES}	600		V
Gate-Emitter Voltage	V _{GES}	± 20		V
Collector Current	@T _C =25	15	30	A
	@T _C =100	7.5	15	A
Pulsed Collector Current	I _{CM} ⁽¹⁾	60		A
Diode Continuous Forward Current	@T _C =25	I _F ⁽¹⁾ 30		A
Diode Maximum Forward Current	I _{FM} ⁽¹⁾	60		A
Maximum Power Dissipation	@T _C =25	41.6	138	W
	@T _C =100	17	55	W
Maximum Junction Temperature	T _j	150		
Storage Temperature Range	T _{stg}	-55 to + 150		

(1) : Pulse width limited by maximum junction temperature.

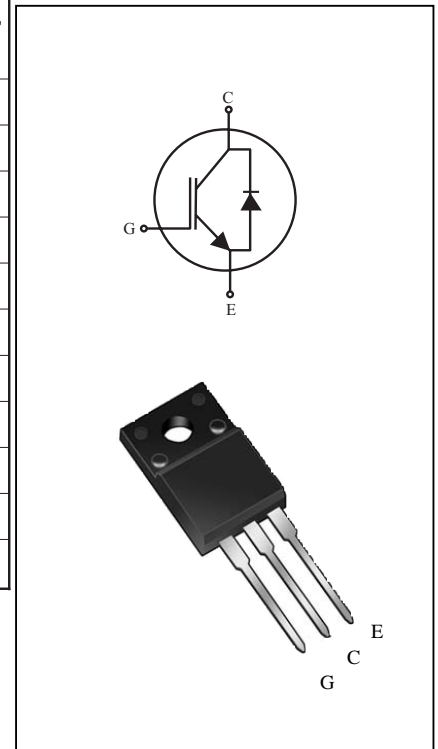

THERMAL CHARACTERISTIC

CHARACTERISTIC	SYMBOL	MAX.		UNIT
		TO-220IS(1)	TO-220AB	
Thermal Resistance, Junction to Case (IGBT)	R _{thJC}	3.0	0.9	/W
Thermal Resistance, Junction to Case (DIODE)	R _{thJCD}	3.6	2.8	/W
Thermal Resistance, Junction to Ambient	R _{thJA}	62.5	62.5	/W

KGT15N60FDA

ELECTRICAL CHARACTERISTICS (Ta=25)

CHARACTERISTIC	SYMBOL	TEST CONDITION	MIN.	TYP.	MAX.	UNIT	
Static							
Collector-Emitter Breakdown Voltage	BV_{CES}	$V_{GE}=0V, I_C=250\mu A$	600	-	-	V	
Collector Cut-off Current	I_{CES}	$V_{GE}=0V, V_{CE}=600V$	-	-	250	μA	
Gate Leakage Current	I_{GES}	$V_{CE}=0V, V_{GE}=\pm 20V$	-	-	± 100	nA	
Gate Threshold Voltage	$V_{GE(th)}$	$V_{GE}=V_{CE}, I_C=2mA$	4.5	5.7	7.0	V	
Collector-Emitter Saturation Voltage	$V_{CE(sat)}$	$V_{GE}=15V, I_C=15A$	-	1.7	1.95	V	
		$V_{GE}=15V, I_C=15A, T_C=125$	-	2.0	-	V	
		$V_{GE}=15V, I_C=30A, T_C=25$	-	2.3	-	V	
Dynamic							
Total Gate Charge	Q_g	$V_{CC}=300V, V_{GE}=15V, I_C=15A$	-	70	-	nC	
Gate-Emitter Charge	Q_{ge}		-	10	-	nC	
Gate-Collector Charge	Q_{gc}		-	35	-	nC	
Turn-On Delay Time	$t_{d(on)}$	$V_{CC}=300V, I_C=15A, V_{GE}=15V, R_G=10$ Inductive Load, $T_C=25$	-	30	-	ns	
Rise Time	t_r		-	20	-	ns	
Turn-Off Delay Time	$t_{d(off)}$		-	90	-	ns	
Fall Time	t_f		-	35	-	ns	
Turn-On Switching Loss	E_{on}		-	0.18	-	mJ	
Turn-Off Switching Loss *Note(1)	E_{off}		-	0.25	-	mJ	
Total Switching Loss	E_{ts}		-	0.43	-	mJ	
Turn-On Delay Time	$t_{d(on)}$		$V_{CC}=300V, I_C=15A, V_{GE}=15V, R_G=10$ Inductive Load, $T_C=125$	-	35	-	ns
Rise Time	t_r			-	25	-	ns
Turn-Off Delay Time	$t_{d(off)}$			-	95	-	ns
Fall Time	t_f	-		70	-	ns	
Turn-On Switching Loss	E_{on}	-		0.28	-	mJ	
Turn-Off Switching Loss *Note(1)	E_{off}	-		0.4	-	mJ	
Total Switching Loss	E_{ts}	-		0.7	-	mJ	
Input Capacitance	C_{ies}	$V_{CE}=30V, V_{GE}=0V, f=1MHz$	-	1270	-	pF	
Output Capacitance	C_{oes}		-	90	-	pF	
Reverse Transfer Capacitance	C_{res}		-	45	-	pF	
Short Circuit Withstand Time	t_{sc}		$V_{CC}=300V, V_{GE}=15V, T_C=100$	5	-	-	μs

*Notes(1) Energy loss include tail current and diode reverse recovery.

Marking

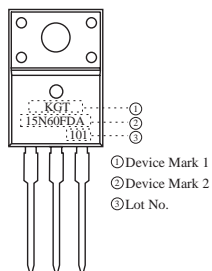

KGT15N60FDA

ELECTRICAL CHARACTERISTIC OF DIODE

CHARACTERISTIC	SYMBOL	TEST CONDITION		MIN.	TYP.	MAX.	UNIT
Diode Forward Voltage	V_F	$I_F = 15A$	$T_C = 25$	-	1.6	2.3	V
			$T_C = 125$	-	1.3	-	
Diode Reverse Recovery Time	t_{rr}	$I_F = 15A$ $di/dt = 800A/\mu s$	$T_C = 25$	-	45	80	ns
			$T_C = 125$	-	70	-	
Diode Peak Reverse Recovery Current	I_{rr}	$I_F = 15A$ $di/dt = 800A/\mu s$	$T_C = 25$	-	12	25	A
			$T_C = 125$	-	22	-	
Diode Reverse Recovery Charge	Q_{rr}	$I_F = 15A$ $di/dt = 800A/\mu s$	$T_C = 25$	-	300	1200	nC
			$T_C = 125$	-	1000	-	

KGT15N60FDA

Fig 1. Saturation Voltage Characteristics

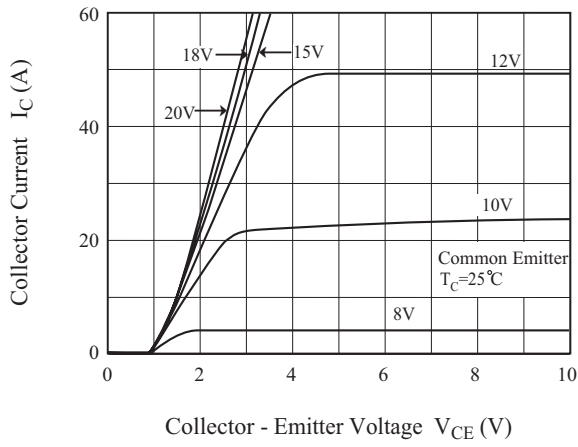

Fig 2. Saturation Voltage Characteristics

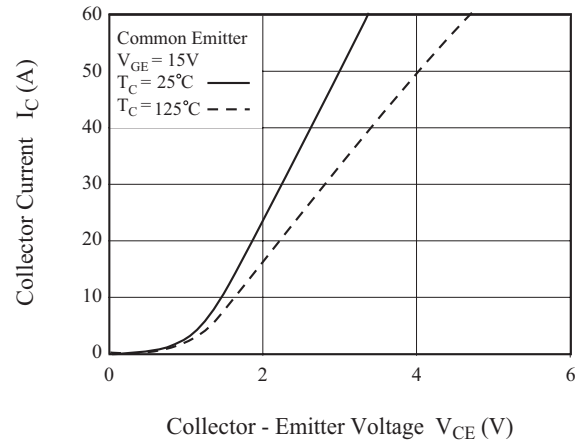

Fig 3. Saturation Voltage vs. Case Temperature

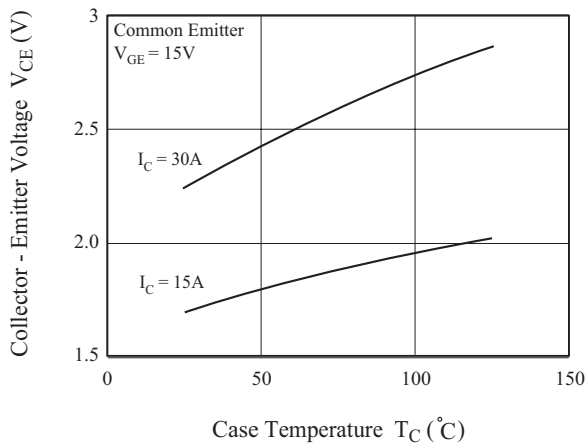

Fig 4. Saturation Voltage vs. V_{GE}

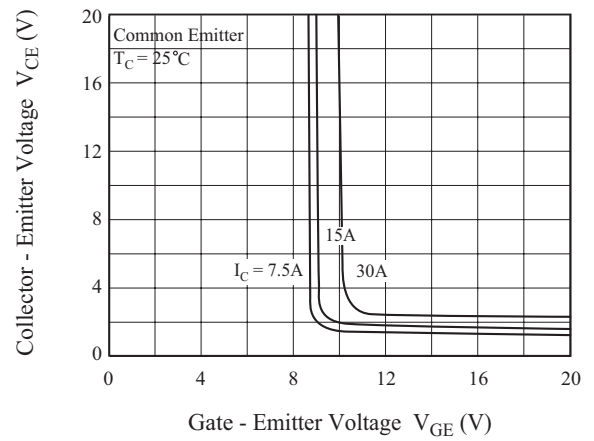

Fig 5. Saturation Voltage vs. V_{GE}

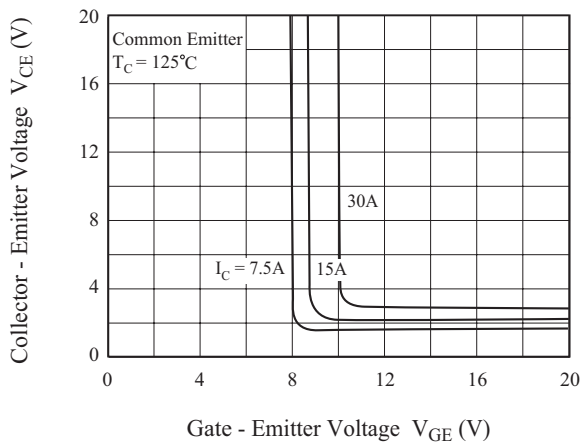
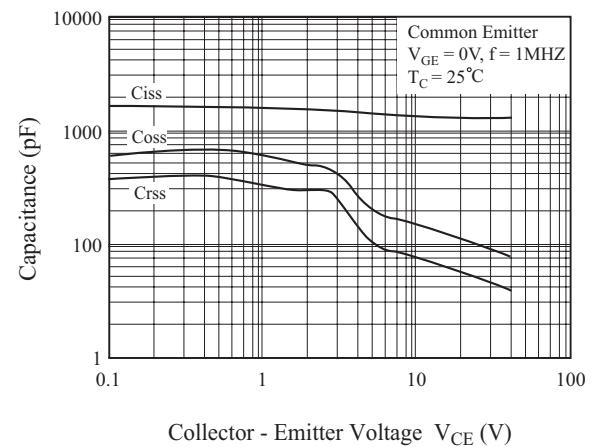

Fig 6. Capacitance Characteristics



KGT15N60FDA

Fig 7. Turn-On Characteristics vs. Gate Resistance

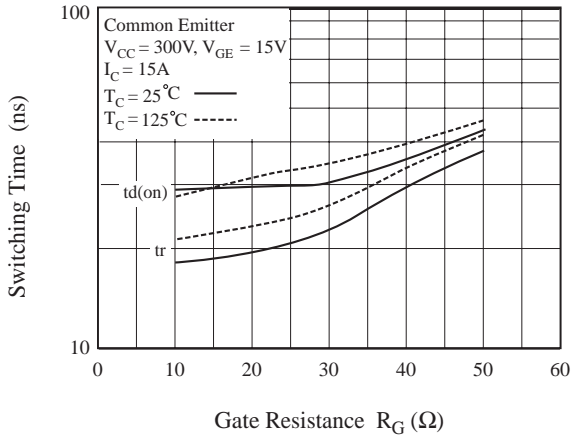

Fig 8. Turn-Off Characteristics vs. Gate Resistance

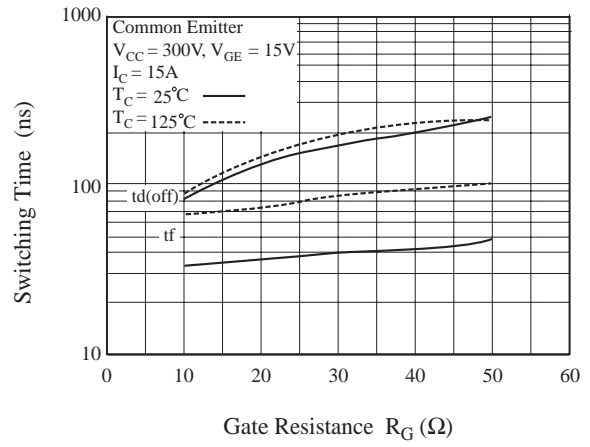

Fig 9. Turn-On Characteristics vs. Collector Current

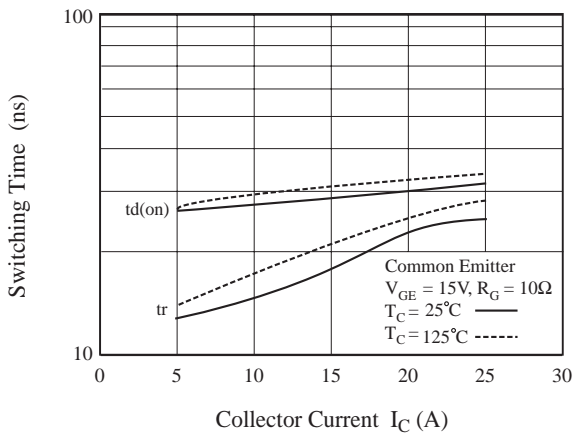

Fig 10. Turn-Off Characteristics vs. Collector Current

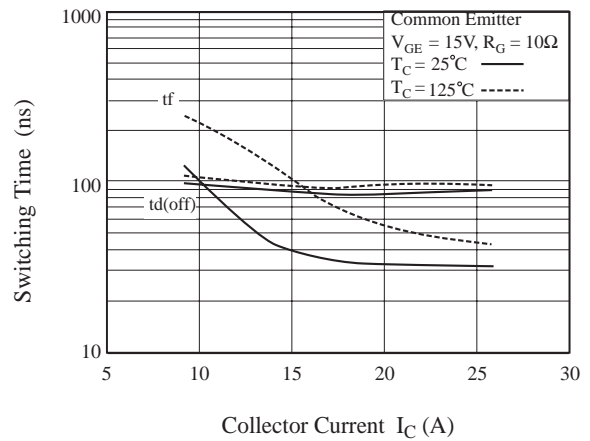

Fig 11. Switching Loss vs. Gate Resistance

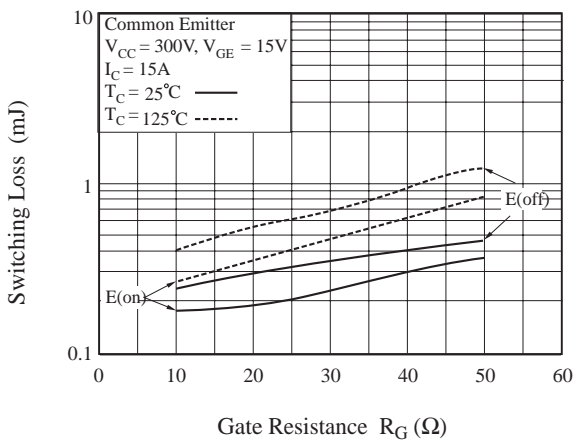
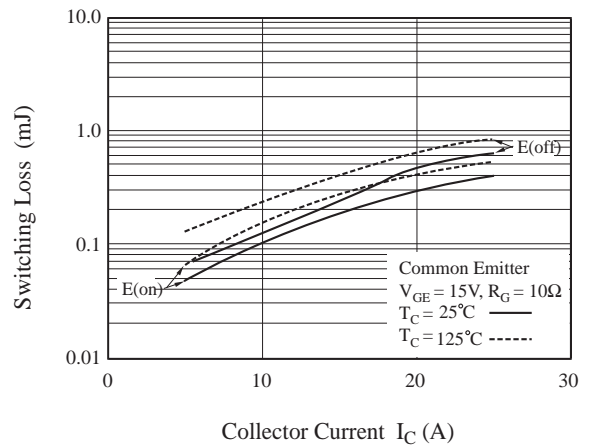

Fig 12. Switching Loss vs. Collector Current



KGT15N60FDA

Fig 13. Gate Charge Characteristics

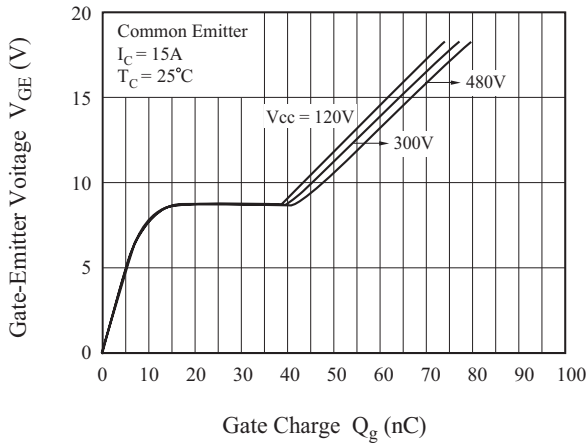

Fig 14. SOA Characteristics

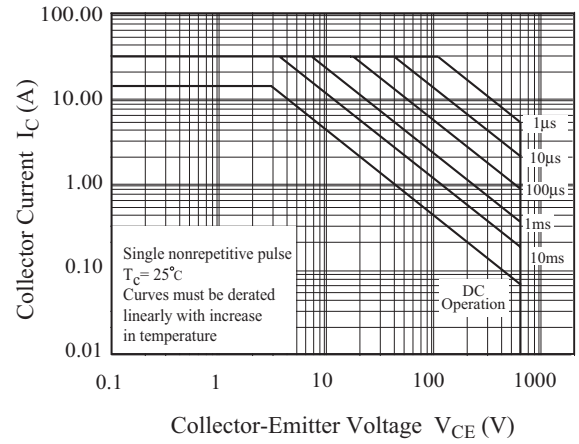

Fig 15. Turn-Off SOA

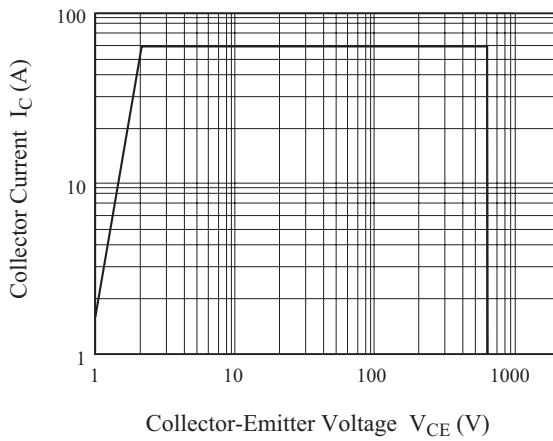
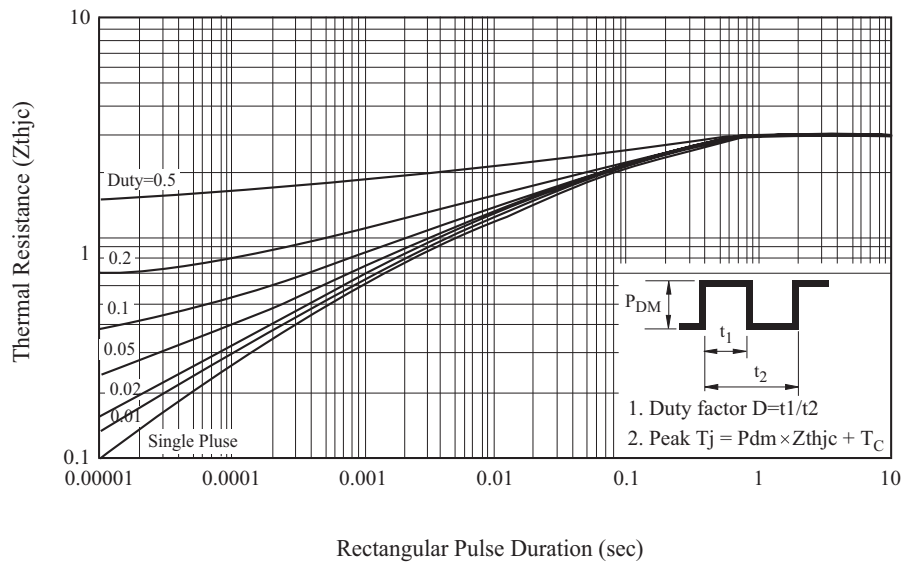

Fig 16. Transient Thermal Impedance of IGBT



KGT15N60FDA

Fig 17. Collector Current vs Case Temperature

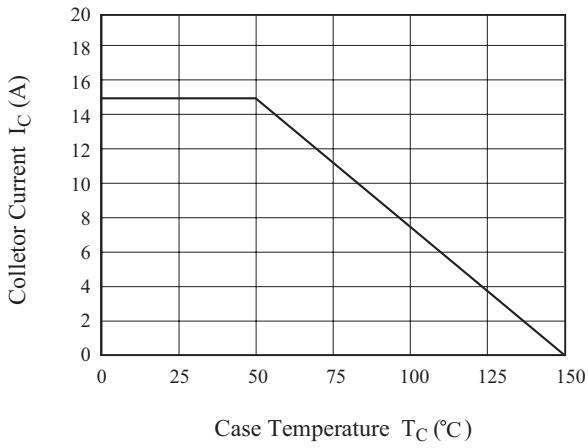

Fig 18. Collector Dissipation vs Case Temperature

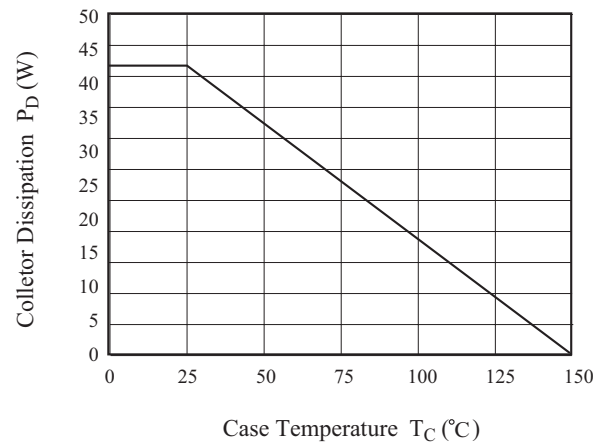

Fig 19. Forward Characteristics

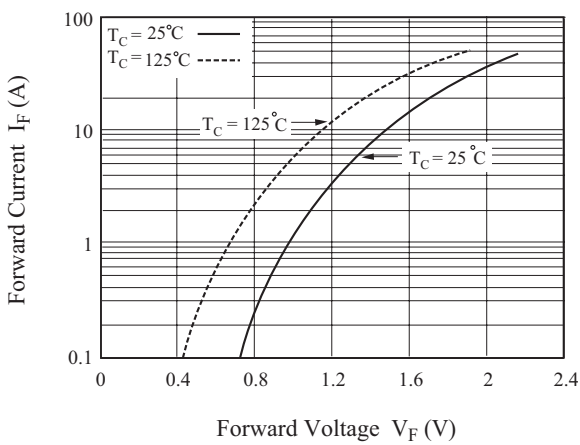

Fig 20. Reverse Recovery Current

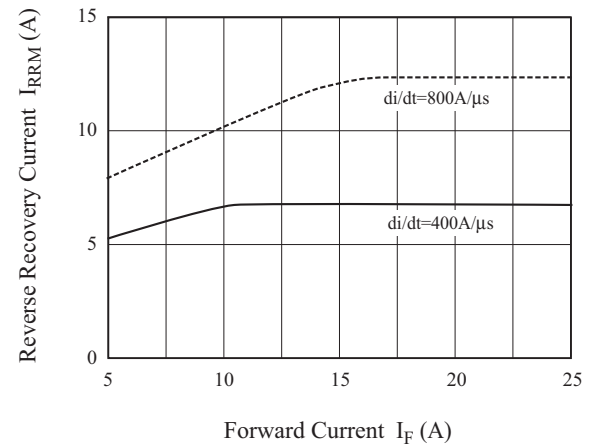

Fig 21. Reverse Recovery Time

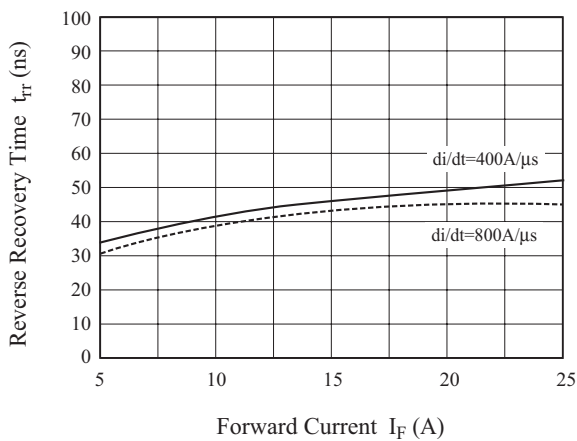

Fig 22. Switching Test Circuit

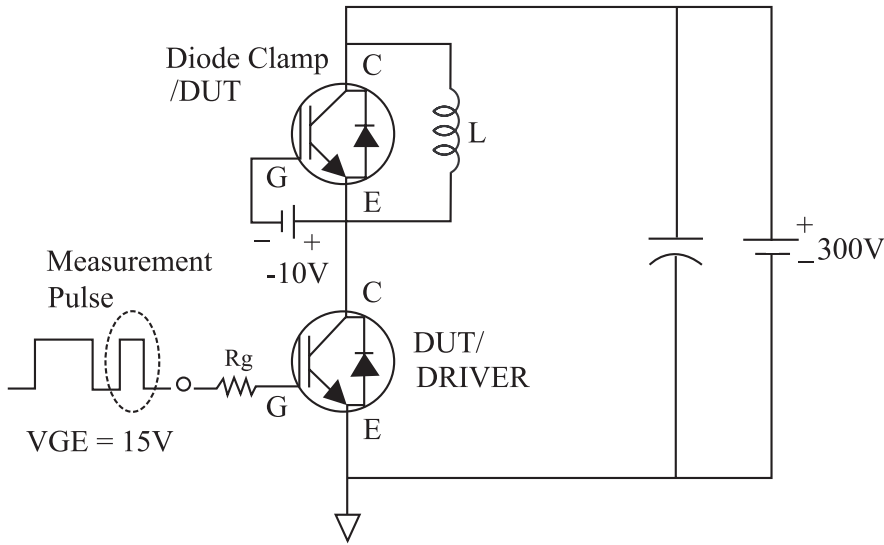

Fig 23. Definition Switching Time & Loss

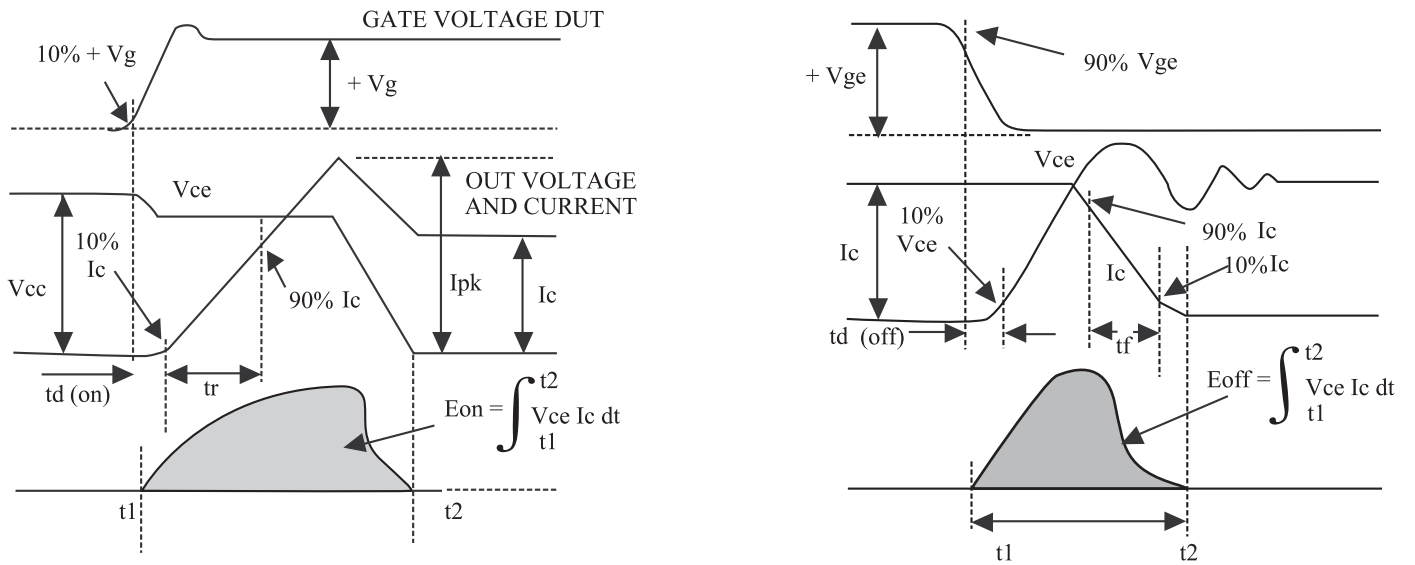

Fig 24. Definition Diode Switching Time

