

General Description

This planar stripe MOSFET has better characteristics, such as fast switching time, low on resistance, low gate charge and excellent avalanche characteristics. It is mainly suitable for electronic ballast and switching mode power supplies.

FEATURES

- $V_{DSS(Min.)} = 900V$, $I_D = 9A$
- Drain-Source ON Resistance :
 $R_{DS(ON)} = 1.05(Typ.) @ V_{GS} = 10V$
- $Q_g(typ.) = 54nC$

MAXIMUM RATING (Tc=25)

CHARACTERISTIC		SYMBOL	RATING	UNIT
Drain-Source Voltage		V_{DSS}	900	V
Gate-Source Voltage		V_{GSS}	± 30	V
Drain Current	@T _C =25	I_D	9.0	A
	Pulsed (Note1)	I_{DP}	36	
Single Pulsed Avalanche Energy (Note 2)		E_{AS}	900	mJ
Repetitive Avalanche Energy (Note 1)		E_{AR}	20.5	mJ
Peak Diode Recovery dv/dt (Note 3)		dv/dt	4.5	V/ns
Drain Power Dissipation	Tc=25	P_D	280	W
	Derate above 25		2.22	W/
Maximum Junction Temperature		T_j	150	
Storage Temperature Range		T_{stg}	-55 150	
Thermal Characteristics				
Thermal Resistance, Junction-to-Case		R_{thJC}	0.45	/W
Thermal Resistance, Case-to-Sink		R_{thCS}	0.24	/W
Thermal Resistance, Junction-to-Ambient		R_{thJA}	40	/W

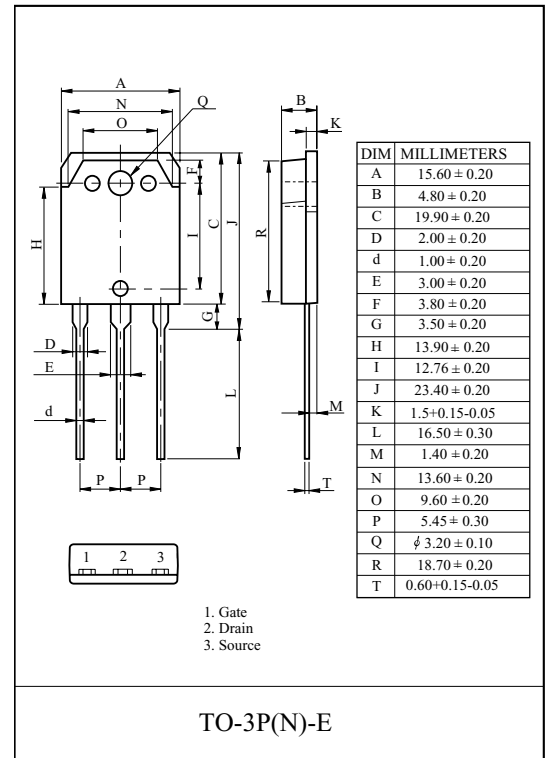

Marking

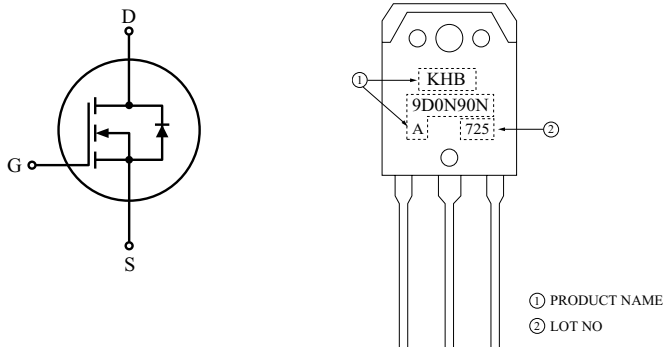

KHB9D0N90NA

ELECTRICAL CHARACTERISTICS (Tc=25 °C)

CHARACTERISTIC	SYMBOL	TEST CONDITION	MIN.	TYP.	MAX.	UNIT
Static						
Drain-Source Breakdown Voltage	BV_{DSS}	$I_D=250\ \mu A, V_{GS}=0V$	900	-	-	V
Breakdown Voltage Temperature Coefficient	BV_{DSS}/T_j	$I_D=250\ \mu A$, Referenced to 25	-	0.99	-	V/°C
Drain Cut-off Current	I_{DSS}	$V_{DS}=900V, V_{GS}=0V$,	-	-	100	μA
Gate Threshold Voltage	V_{th}	$V_{DS}=V_{GS}, I_D=250\ \mu A$	2.0	-	4.0	V
Gate Leakage Current	I_{GSS}	$V_{GS}=\pm 30V, V_{DS}=0V$	-	-	± 100	nA
Drain-Source ON Resistance	$R_{DS(ON)}$	$V_{GS}=10V, I_D=4.5A$	-	1.05	1.4	Ω
Dynamic						
Total Gate Charge	Q_g	$V_{DS}=450V, I_D=9.0A$ $V_{GS}=10V$ (Note4,5)	-	54	69	nC
Gate-Source Charge	Q_{gs}		-	12	-	
Gate-Drain Charge	Q_{gd}		-	17	-	
Turn-on Delay time	$t_{d(on)}$	$V_{DD}=450V$, $R_G=25\ \Omega$, $I_D=9.0A$ (Note4,5)	-	48	96	ns
Turn-on Rise time	t_r		-	80	160	
Turn-off Delay time	$t_{d(off)}$		-	180	360	
Turn-off Fall time	t_f		-	140	280	
Input Capacitance	C_{iss}	$V_{DS}=25V, V_{GS}=0V, f=1.0MHz$	-	2663	3462	pF
Output Capacitance	C_{oss}		-	183	238	
Reverse Transfer Capacitance	C_{rss}		-	20	26	
Source-Drain Diode Ratings						
Continuous Source Current	I_S	$V_{GS}<V_{th}$	-	-	9.0	A
Pulsed Source Current	I_{SP}		-	-	36.0	
Diode Forward Voltage	V_{SD}	$I_S=9.0A, V_{GS}=0V$	-	-	1.4	V
Reverse Recovery Time	t_{rr}	$I_S=9.0A, V_{GS}=0V$, $dI_S/dt=100A/\mu s$	-	550	-	ns
Reverse Recovery Charge	Q_{rr}		-	6.5	-	μC

Note 1) Repetivity rating : Pulse width limited by junction temperature.

Note 2) $L = 21mH, I_{AS}=9.0A, V_{DD}=50V, R_G = 25\ \Omega$, Starting $T_j = 25\ ^\circ C$.

Note 3) $I_S = 9.0A, dI/dt = 200A/\mu s, V_{DD} = BV_{DSS}$, Starting $T_j = 25\ ^\circ C$.

Note 4) Pulse Test : Pulse width $300\ \mu s$, Duty Cycle 2% .

Note 5) Essentially independent of operating temperature.

KHB9D0N90NA

$I_D - V_{DS}$

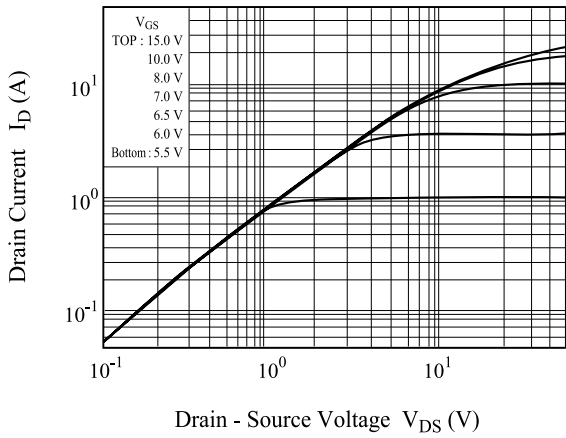

$I_D - V_{GS}$

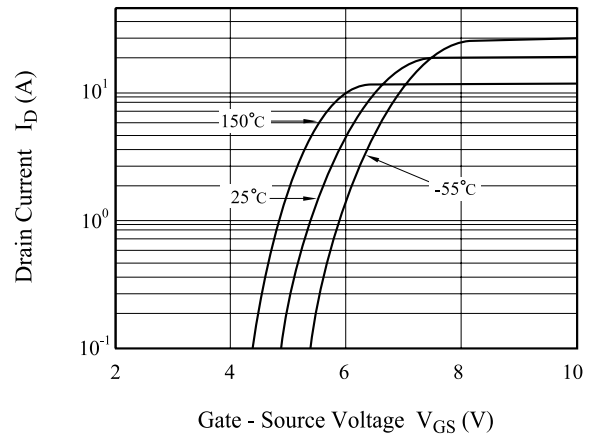

$BV_{DSS} - T_j$

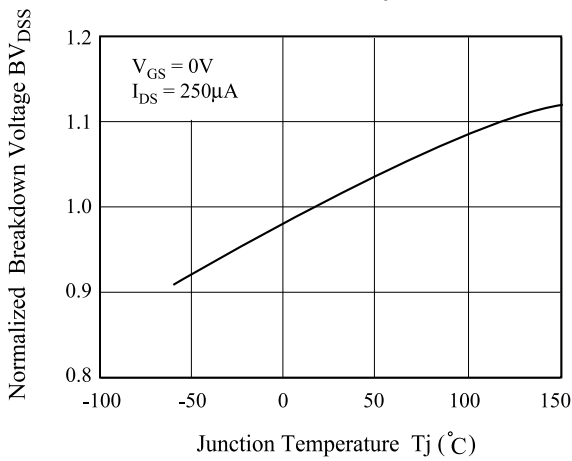

$R_{DS(ON)} - I_D$

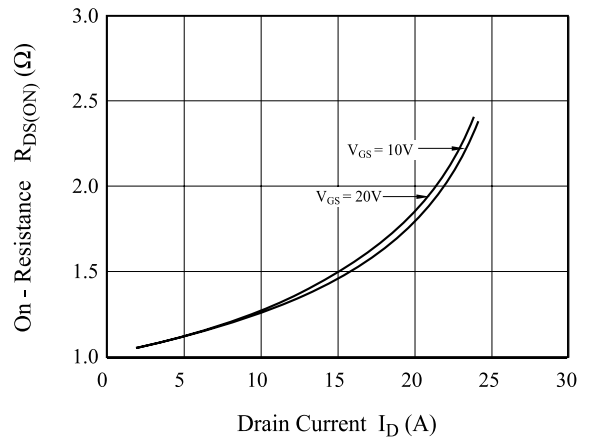

$I_S - V_{SD}$

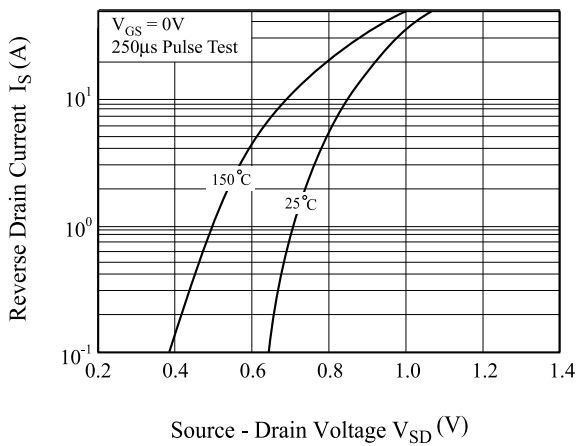

$R_{DS(ON)} - T_j$

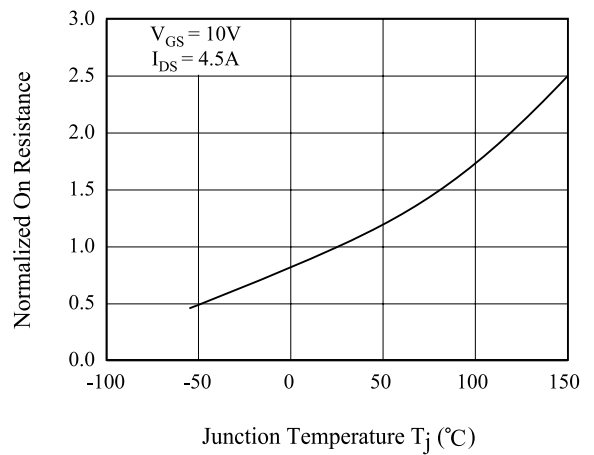

KHB9D0N90NA

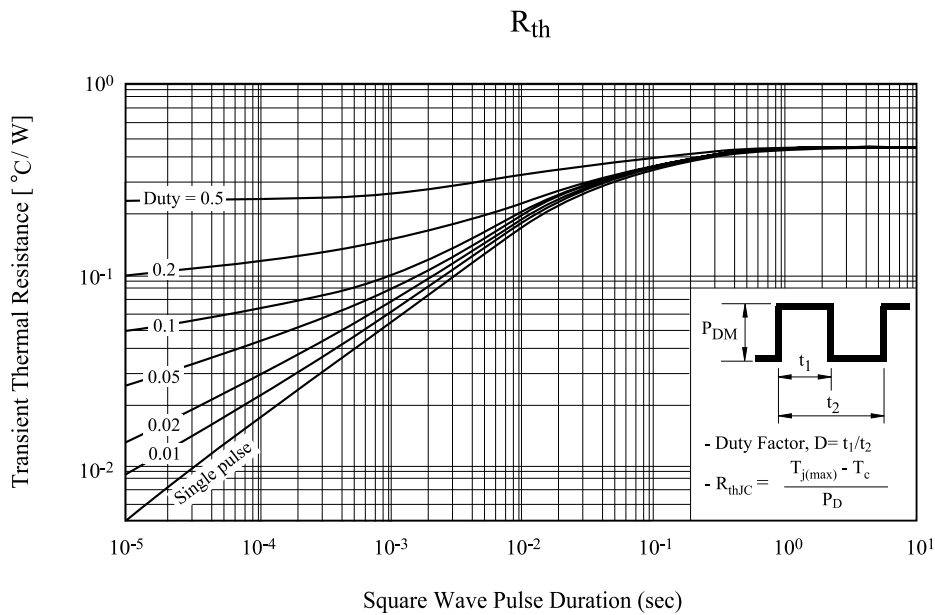
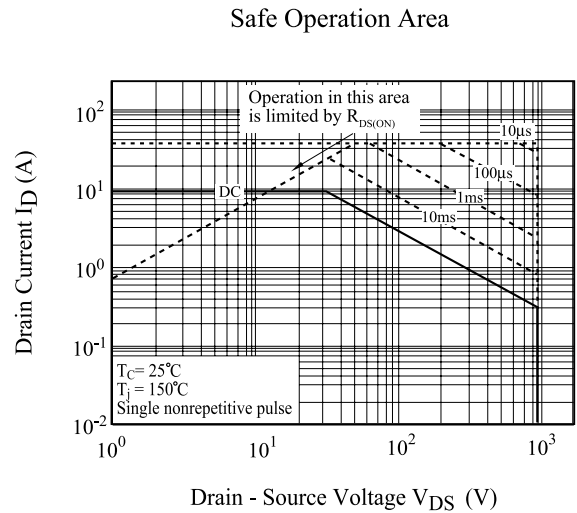
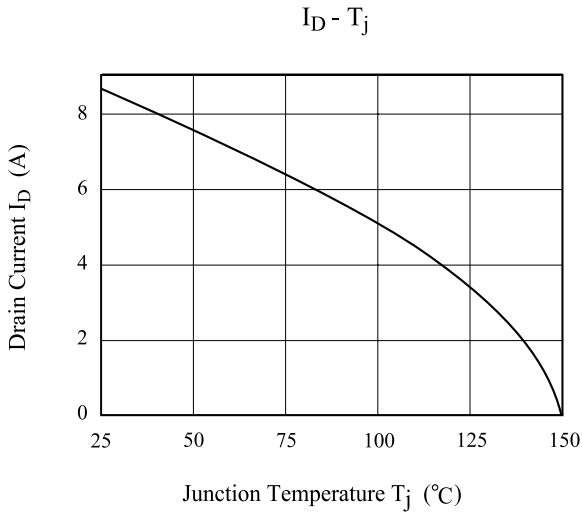
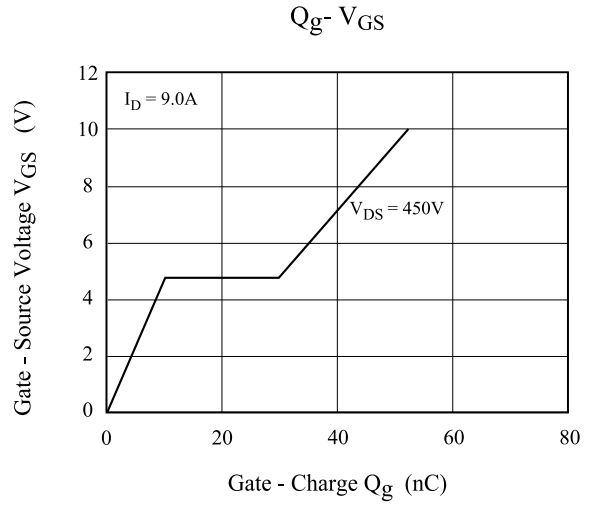
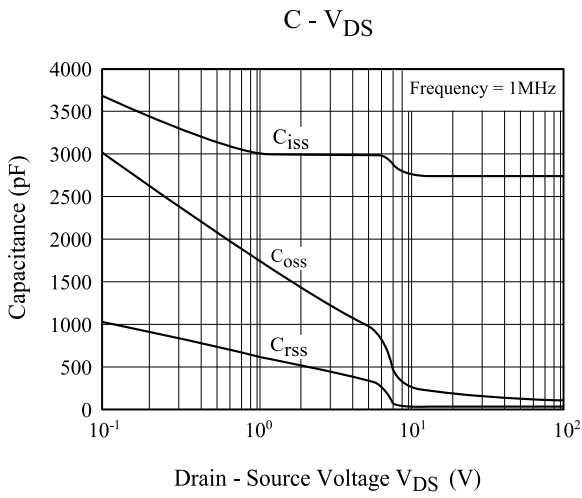

KHB9D0N90NA

- Gate Charge

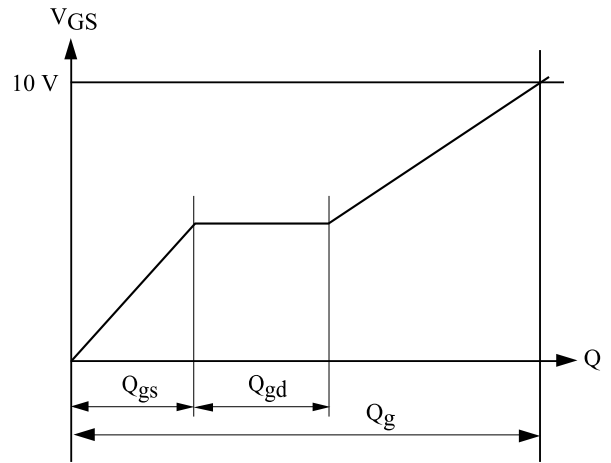
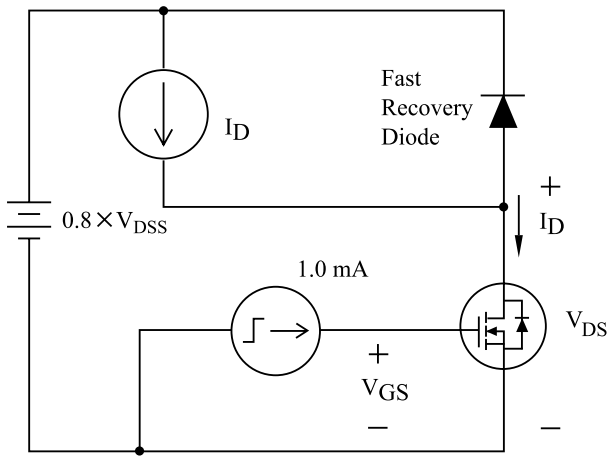

- Single Pulsed Avalanche Energy

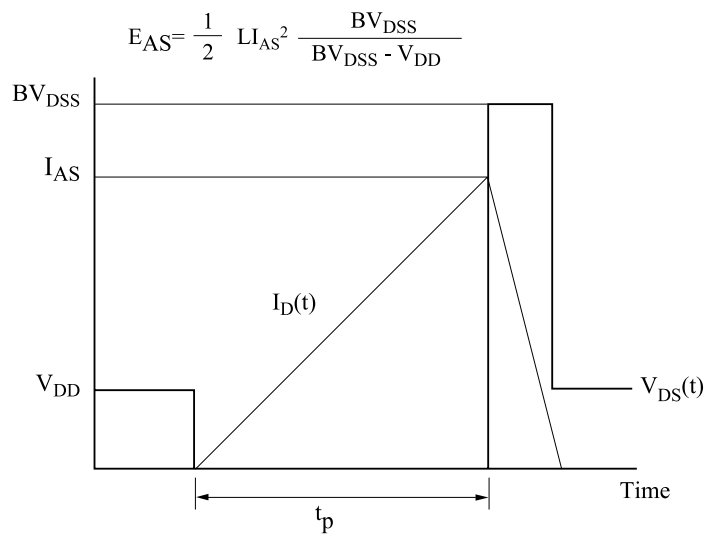
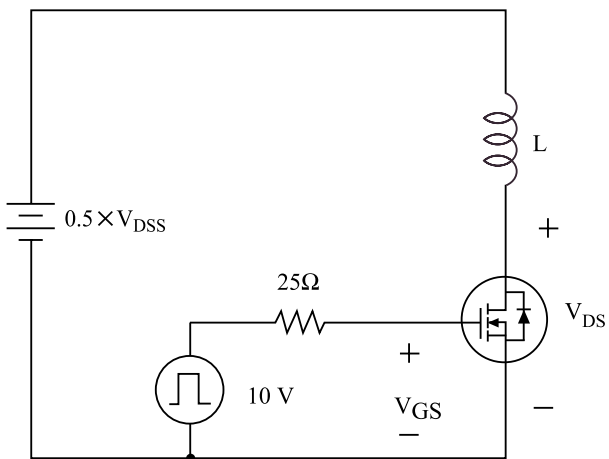

KHB9D0N90NA

- Resistive Load Switching

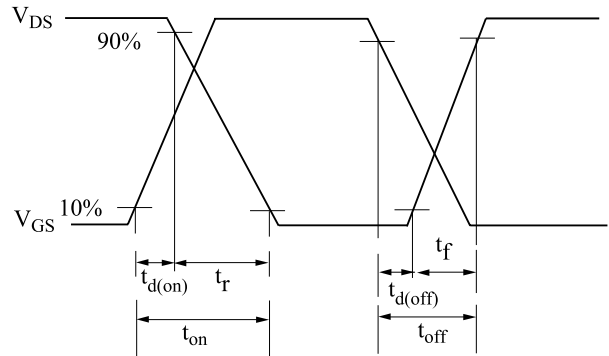
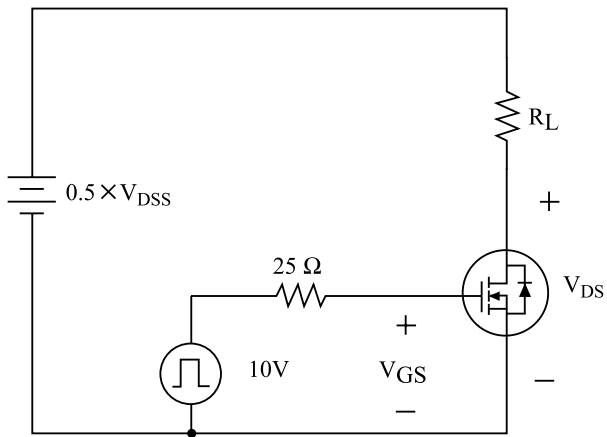

- Source - Drain Diode Reverse Recovery and dv/dt

