

SPEC.NO.	TQ3C-8EACO-E1CWJ09-00
DATE	April 09, 2001

S P E C

FOR :

TYPE : KHS072VG1MB-L89

CONTENTS

1. Application
2. Construction and Outline
3. Mechanical Specifications
4. Absolute Maximum Ratings
5. Electrical Characteristics
6. Optical Characteristics
7. Circuit Block Diagram
8. Interface Signals
9. Interface Timing Chart
10. Data and Screen
11. Input Timing Characteristics
12. Supply Voltage Sequence Condition
13. Backlight Characteristics
14. Lot Number Identification
15. Warranty
16. Precautions for Use
17. Reliability Data / Environmental Test
18. Outline Drawing

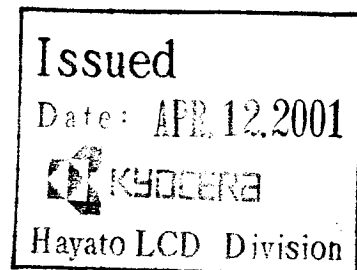

KYOCERA CORPORATION
KAGOSHIMA HAYATO PLANT
LCD DIVISION

This specification is subject to change without notice.
Consult Kyocera before ordering.

Original	Designed by :Engineering Dept.			Confirmed by :QA Dept.	
Issue Data	Prepared	Checked	Approved	Checked	Approved
March 28, 2001	T. Yamazuchi	M. Fujitani	H. Ohno	S. Hayashi	Y. Yoshida

Caution

1. This Kyocera LCD module has been specifically designed for use only in electronic devices in the areas of audio control, office automation, industrial control, home appliances, etc. The modules should not be used in medical applications where module failure could result in physical harm or loss of life, and Kyocera expressly disclaims any and all liability relating in any way to the use of the module in such medical applications.
2. Customer agrees to indemnify, defend and hold Kyocera harmless from and against any and all actions, claims, losses, damages, liabilities, awards, costs, and expenses, including legal fees, resulting from or arising out of Customer's use, or sale for use, of Kyocera modules in medical applications.
3. Kyocera shall have the right, which Customer hereby acknowledges, to immediately scrap or destroy tooling for Kyocera modules for which no Purchase Orders have been received from the Customer in a two-year period.

Revision Record

Date	Designed by: Engineering Dept.			Confirmed by: QA Dept.	
	Prepared	Checked	Approved	Checked	Approved
Rev. No.	Date	Page	Descriptions		

1. Application

This data sheet defines the specification for a $(640 \times R.G.B) \times 480$ dot, STN Transflective color dot matrix type Liquid Crystal Display with CFL backlight.

2. Construction and Outline

$(640 \times R.G.B) \times 480$ dots, COB type LCD with CFL backlight.

Backlight system : Side-edge type CFL (1 tube).

Inverter : Option.
Recommendable Inverter : PH-BLC08-K2 (HITACHI MEDIA ELECTRONICS)
or Equivaloent.

Polarizer : Glare treatment.

Additional circuit : Bias voltage circuit, Randomizing circuit, DC-DC converter

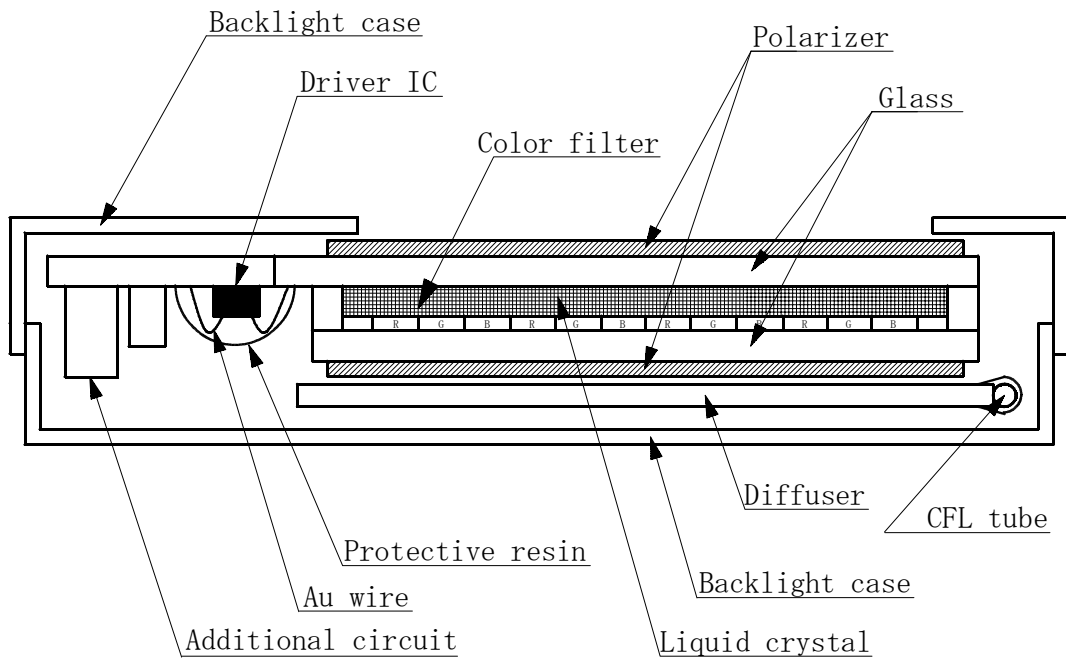

This drawing is showing conception only.

3. Mechanical Specifications

ITEM	SPECIFICATION	UNIT
Outline dimensions	179.3 (W) × 130.5 (H) × 6 (D)	mm
Effective viewing area	147.90 (W) × 111.42 (H)	mm
Dot number	(640×R. G. B) (W) × 480 (H)	Dots
Dot size	0.056 (W) × 0.208 (H)	mm
Dot pitch	0.076 (W) × 0.228 (H)	mm
Display color *1	White *2	—
Base color *1	Black *2	—
Mass	170	g

*1 Due to the characteristics of the LC material, the color vary with environmental temperature.

*2 Negative-type display

Display data "H" :R, G, B Dots ON : White
 Display data "L" :R, G, B Dots OFF : Black

4. Absolute Maximum Ratings

4-1 Electrical absolute maximum ratings

ITEM	SYMBOL	MIN.	MAX.	UNIT
Supply voltage for logic	VDD	0	6.0	V
Supply voltage for LCD driving	VCONT	0	VDD	V
Input Signal voltage *1	Vin	0	VDD+0.3	V

*1 Input signal :CP, LOAD, FRM, DISP, UD0~UD7, LD0~LD7

4-2 Environmental absolute maximum ratings

ITEM	SYMBOL	MIN	MAX	UNIT
Operating temperature *1	Top	0	50	°C
Storage temperature *2	T _{STO}	-20	60	°C
Operating humidity *3	Hop	10	85	%RH
Storage humidity *3	H _{STO}	10	*4	%RH
Vibration	—	*5	*5	—
Shock	—	*6	*6	—

*1 LCD's display quality shall not be guaranteed at the temperature range of :
below 0°C and upper 40°C.

*2 Temp. = -20°C < 48 h , Temp = 60°C < 168 h
Store LCD panel at normal temperature/humidity. Keep it free from vibration and shock.
LCD panel that is kept at low or high temperature for a long time can be defective due to
the other conditions, even if the temperature satisfies standard.

*3 Non-condensation.

*4 Temp. ≤ 40°C, 85% RH Max.
Temp. > 40°C, Absolute Humidity shall be less than 85%RH at 40°C.

*5

Frequency	10~55 Hz	Converted to acceleration value : (0.3~9 m/s ²)
Vibration width	0.15 mm	
Interval	10-55-10 Hz	1 minute

2 hours in each direction X/Y/Z (6 hours as total)
EIAJ ED-2531

*6 Acceleration: 490 m/s²
Pulse width : 11 ms
3 times in each direction : ±X/±Y/±Z.
EIAJ ED-2531

5. Electrical Characteristics

Temp. = 25°C, VDD = +3.3V ± 0.3V

ITEM	SYMBOL	CONDITION	MIN.	TYP.	MAX.	UNIT
Supply voltage for logic	VDD	—	3.0	3.3	3.6	V
LCD driving voltage *1	Vop= VCONT	0 °C	0.80	—	—	V
		25 °C	1.35	1.95	2.55	V
		50 °C	—	—	2.80	V
Input voltage	Vin	"H" level	0.8VDD	—	VDD	V
		"L" level	0	—	0.2VDD	V
Clock frequency	f _{cp}		4.03	4.32	10.0	MHz
Frame frequency *2	f _{FRM}		70	75	80	Hz
Current consumption for logic	IDD	—	—	(126)	(189)	mA
Power consumption	Pdisp		—	(416)	(624)	mW

*1 Maximum contrast ratio is obtained by adjusting the LCD supply voltage (Vop= VCONT) for driving LCD.

*2 In consideration of display quality, it is recommended that frame frequency is set in the range of 70–80Hz. When you have to use higher frame and clock frequencies, confirm the LCD's performance and quality prior to finalizing the frequency values: Generally, as frame and clock frequencies become higher current consumption will get bigger and display quality will be degraded.

*3 Display high frequency pattern, (see below).
VDD = 3.3V , Vop = VCONT , f_{FRM} = 75 Hz , f_{cp} = 4.32MHz
Pattern:

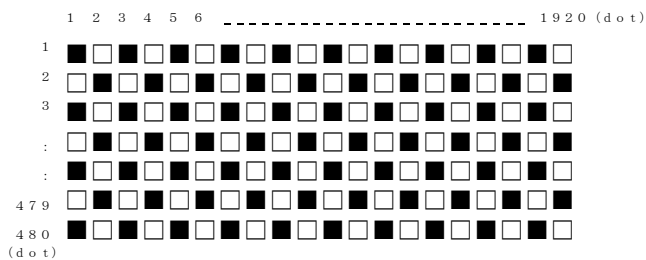

6. Optical Characteristics

6-1. Reflective mode

Measuring Spot = ϕ 6mm , Temp. = 25°C

ITEM		SYMBOL	CONDITION	MIN.	TYP.	MAX.	UNIT
Response	Rise	Tr	$\theta = \phi = \theta$	—	(200)	(300)	ms
	Down	Td	$\theta = \phi = \theta$	—	(150)	(250)	ms
Contrast ratio		CR	$\theta = \phi = \theta$	(5.0)	(10.0)	—	—
Reflectance		ρ	—	(2.5)	(5.0)	—	%

Optimum contrast is obtained by adjusting the LCD driving voltage(Vop) while at the viewing angle of $\theta = \phi = 0^\circ$.

6-2. Transmissive mode

Measuring Spot = ϕ 6mm , Temp. = 25°C

ITEM		SYMBOL	CONDITION	MIN.	TYP.	MAX.	UNIT	
Response time	Rise	Tr	$\theta = \phi = 0^\circ$	—	(200)	(300)	ms	
	Down	Td	$\theta = \phi = 0^\circ$	—	(150)	(250)	ms	
Viewing angle range		θ	CR \geq 2	$\phi = 0^\circ$	(-30)	—	(40)	deg.
		ϕ		$\theta = 0^\circ$	(-50)	—	(50)	deg.
Contrast ratio		CR	$\theta = \phi = 0^\circ$	(10)	(20.0)	—	—	
Brightness(IL=5.0mA)		L	—	(40)	(80)	—	cd/m ²	
Chromaticity coordinates	Red	x	$\theta = \phi = 0^\circ$	(0.44)	(0.49)	(0.54)	—	
		y		(0.27)	(0.32)	(0.37)		
	Green	x	$\theta = \phi = 0^\circ$	(0.25)	(0.30)	(0.35)		
		y		(0.41)	(0.46)	(0.51)		
	Blue	x	$\theta = \phi = 0^\circ$	(0.11)	(0.16)	(0.21)		
		y		(0.11)	(0.16)	(0.21)		
	White	x	$\theta = \phi = 0^\circ$	(0.25)	(0.30)	(0.35)		
		y		(0.27)	(0.32)	(0.37)		

Optimum contrast is obtained by adjusting the LCD driving voltage(Vop) while at the viewing angle of $\theta = \phi = 0^\circ$.

6-3. Definition of V_{op}

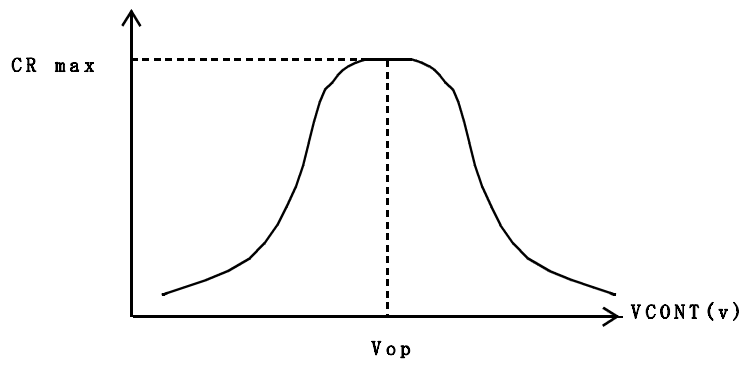

6-4. Definition of response time

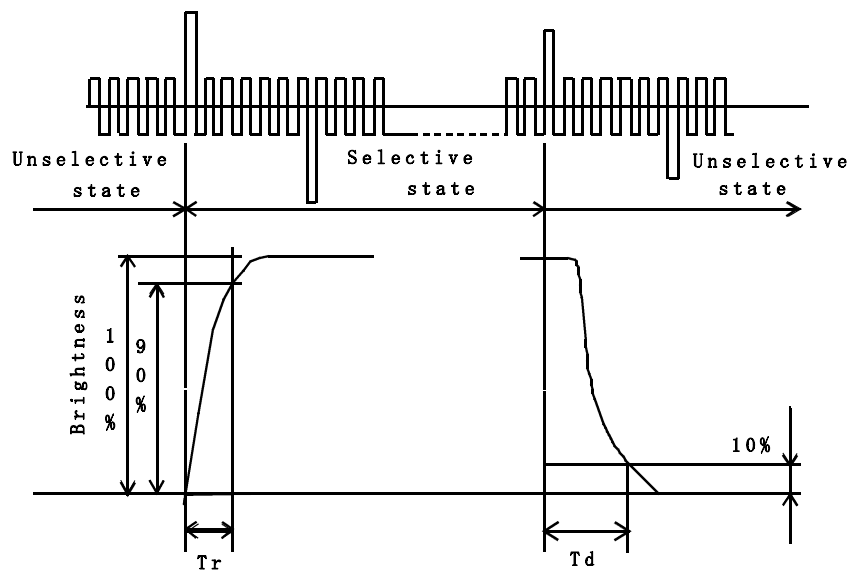

6-5. Definition of viewing angle

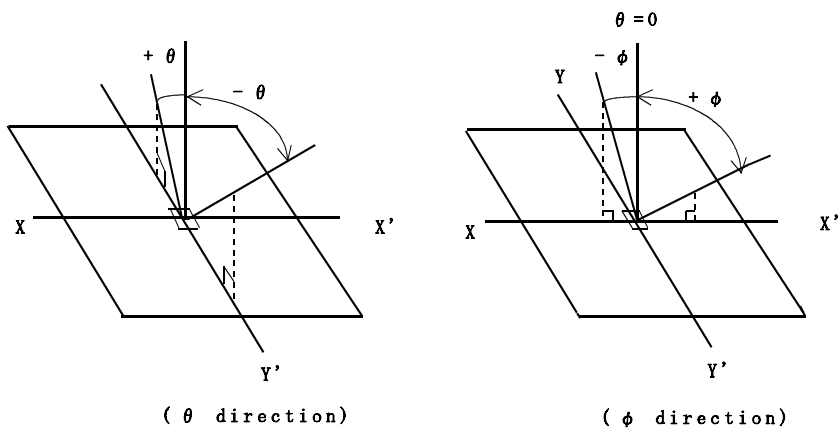

6-6. Measurement method of reflectance

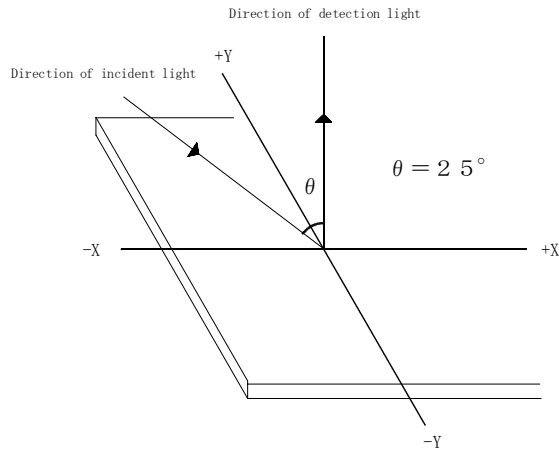

6-7. Definition of Contrast (Reflective Mode)

$$CR(\text{Contrast}) = \frac{\text{Reflection Brightness at all pixels "White"}}{\text{Reflection Brightness at all pixels "Black"}}$$

6-8. Definition of Contrast (Transmissive Mode)

$$CR(\text{Contrast}) = \frac{\text{Brightness at all pixels "White"}}{\text{Brightness at all pixels "Black"}}$$

6-9. Definition of Reflectance:

$$\rho (\text{Reflectance}) = \frac{\text{Measured Reflection Brightness}}{\text{Reflection Brightness against Standard White Board}} \times 100(\%)$$

6-10. Measuring points

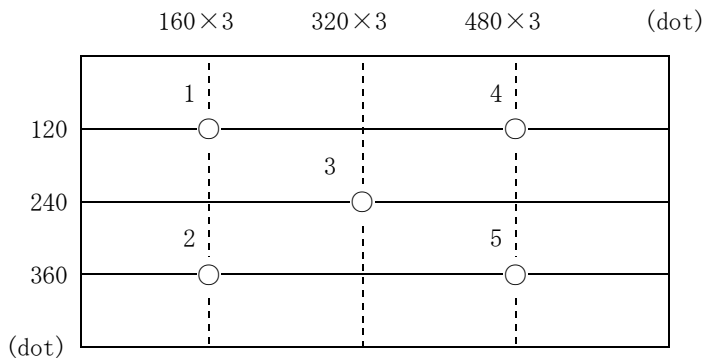

- 1) Rating is defined as the average brightness inside the viewing area.
- 2) 30 minutes after CFL is turned on. (Ambient Temp. = 25°C)
- 3) The inverter should meet the eccentric conditions;
 - Sine, symmetric waveform without spike in positive and negative.

7. Circuit Block Diagram

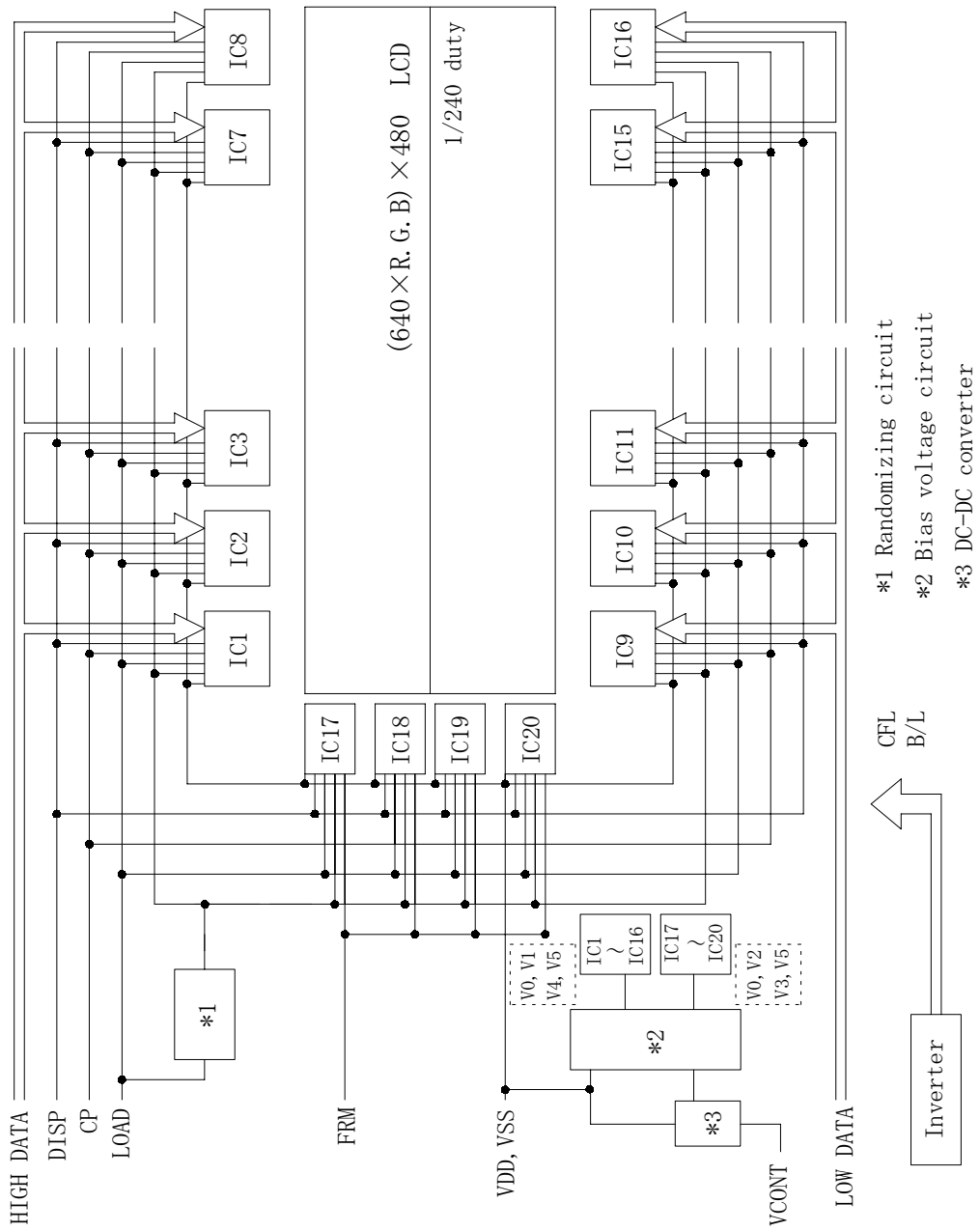

7-1. Power supply

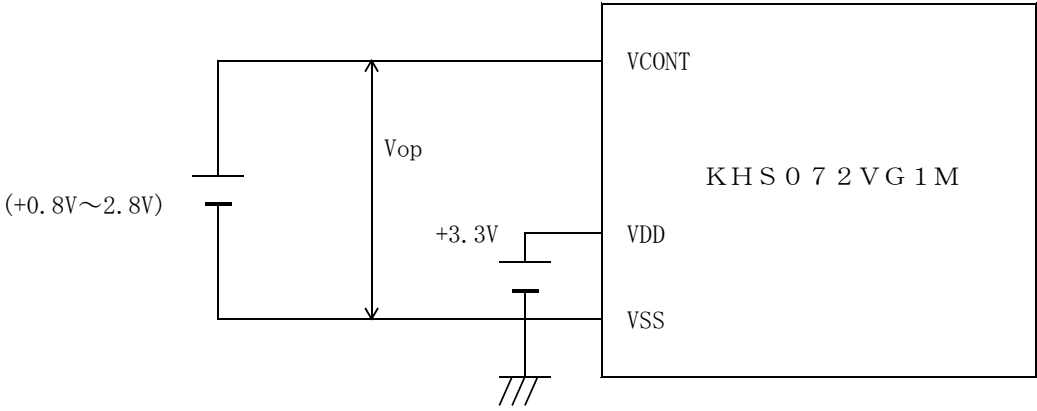

8. Interface signals

8-1. LCD

PIN NO.	SYMBOL	DESCRIPTION	LEVEL
1	LD4	Display data (Lower column)	H (ON), L (OFF)
2	VSS	GND	—
3	LD5	Display data (Lower column)	H (ON), L (OFF)
4	FRM	Synchronous signal for driving scanning line	H
5	LD6	Display data (Lower column)	H (ON), L (OFF)
6	LOAD	Data signal latch clock	H → L
7	LD7	Display data (Lower column)	H (ON), L (OFF)
8	VSS	GND	—
9	VSS	GND	—
10	CP	Data signal shift clock	H → L
11	LD0	Display data (Lower column)	H (ON), L (OFF)
12	VCONT	LCD adjust voltage	—
13	LD1	Display data (Lower column)	H (ON), L (OFF)
14	VDD	Power supply for logic	—
15	VSS	GND	—
16	VDD	Power supply for logic	—
17	LD2	Display data (Lower column)	H (ON), L (OFF)
18	DISP	Display control signal	H (ON), L (OFF)
19	LD3	Display data (Lower column)	H (ON), L (OFF)
20	NC	No connect	—
21	VSS	GND	—
22	HD3	Display data (Upper column)	H (ON), L (OFF)
23	HD4	Display data (Upper column)	H (ON), L (OFF)
24	HD2	Display data (Upper column)	H (ON), L (OFF)
25	HD5	Display data (Upper column)	H (ON), L (OFF)
26	HD1	Display data (Upper column)	H (ON), L (OFF)
27	VSS	GND	—
28	HD0	Display data (Upper column)	H (ON), L (OFF)
29	HD6	Display data (Upper column)	H (ON), L (OFF)
30	VSS	GND	—
31	HD7	Display data (Upper column)	H (ON), L (OFF)

LCD side connector : DF9B-31P-1V (HIROSE)
 Recommended matching connector : DF9B-31S-1V (HIROSE)

8-2. CFL

PIN No	SYMBOL	DESCRIPTION	LEVEL
1	HV	Power supply for CFL	AC
2	NC	—	—
3	GND	Ground line (from inverter)	—

LCD side connector : BHR-03VS-1 (JST)
 Recommended matching connector : SM02-(8.0)B-BHS-1 (JST)

9. Interface Timing Chart

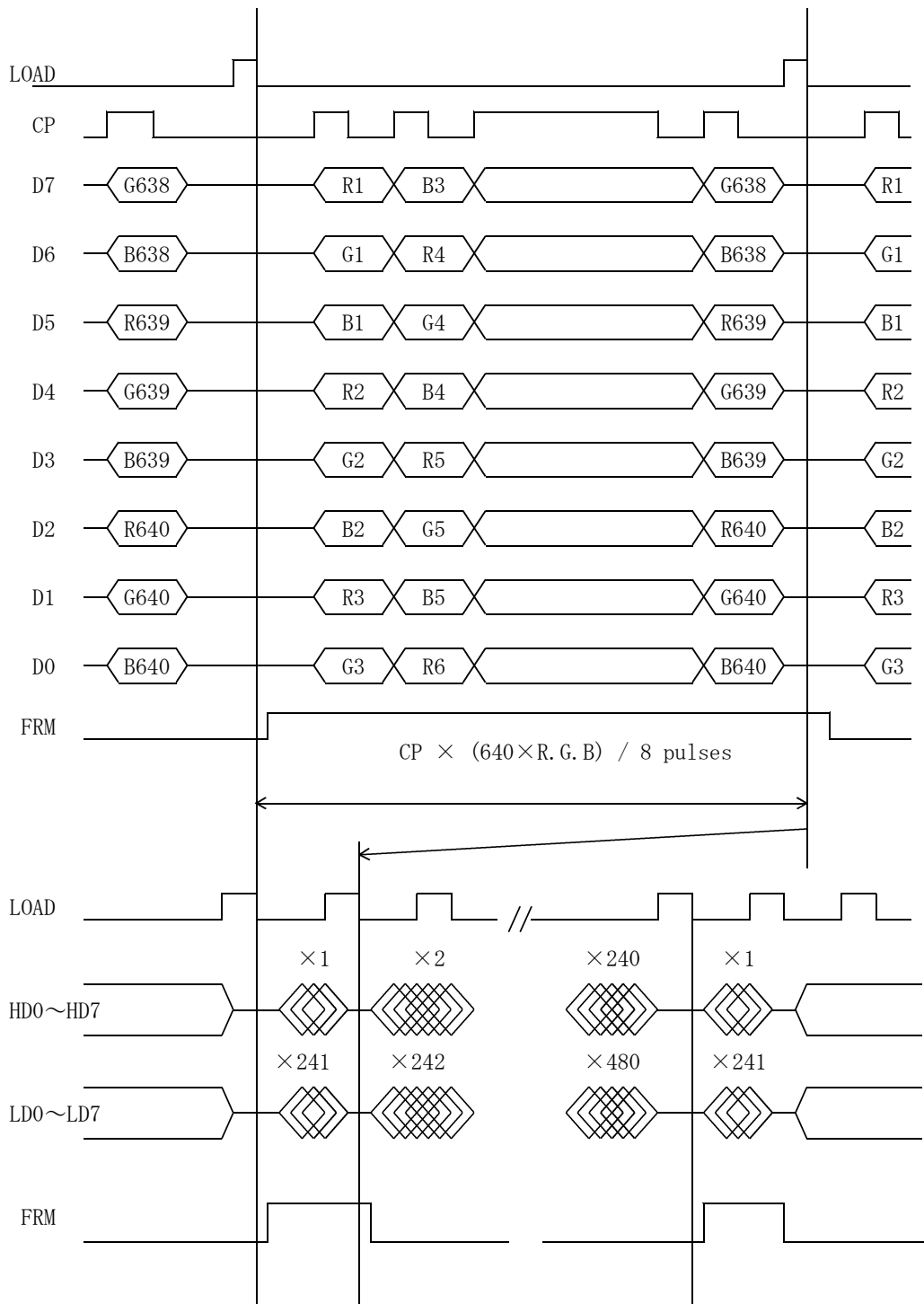

* The cycle of load signal should be stable and continuously applied without interruption.

* The above-mentioned timing chart shows a reference to set up a LCD module, not an electrical rating

10. Data and Screen

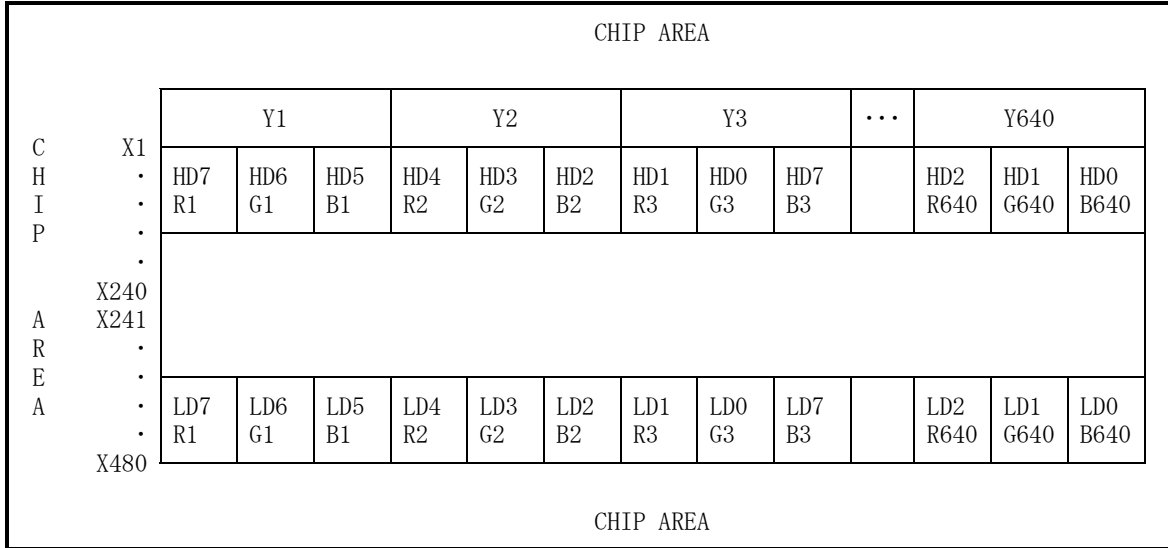

11. Input Timing Characteristics

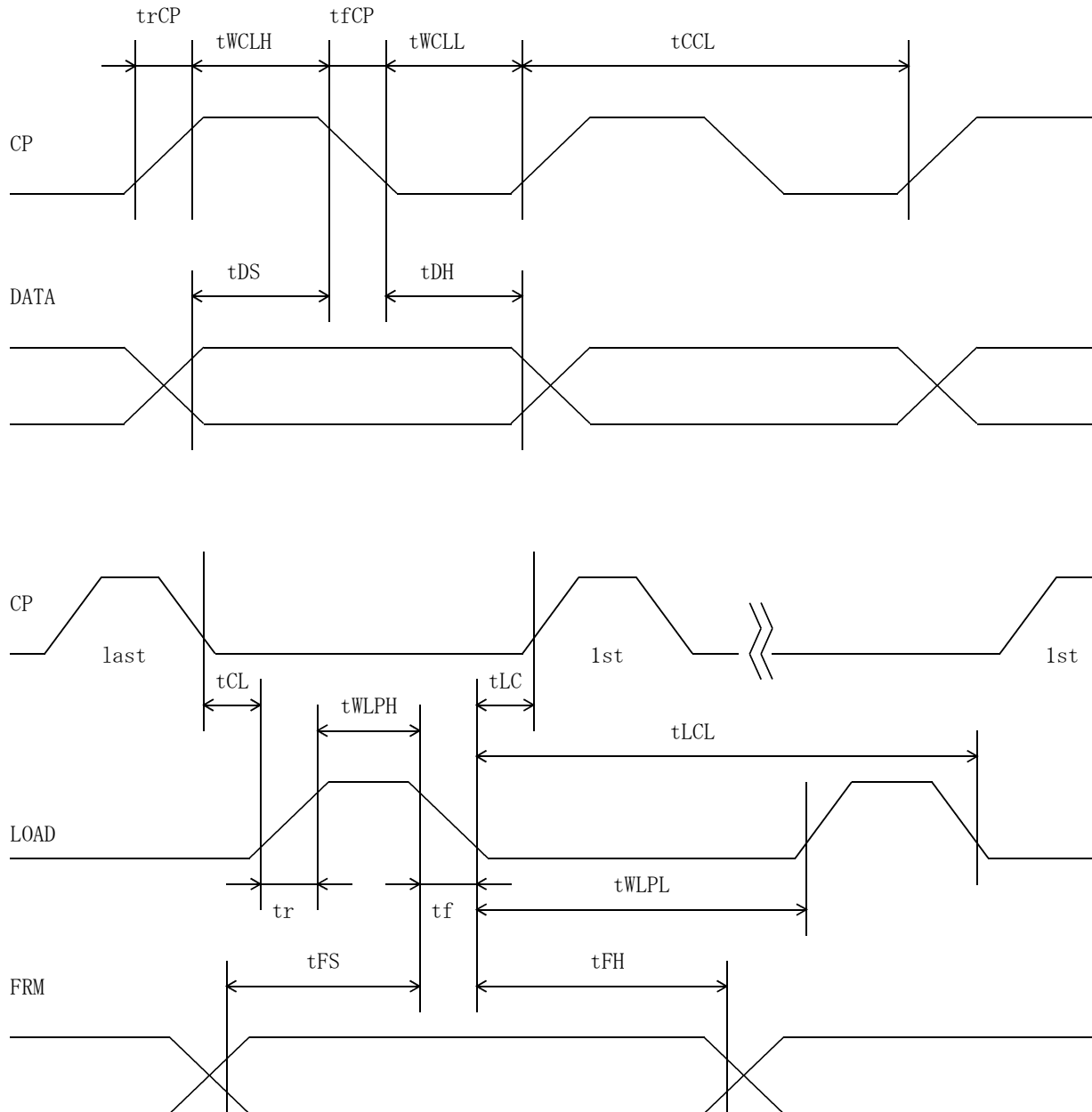

11-1. Switching characteristics

Input Characteristics ; VDD = +3.3V ± 0.3V, Temp. = 25 °C

ITEM	SYMBOL	MIN.	MAX.	UNIT
CP Cycle *1,*2	tCCL	100	—	ns
CP "H" Pulse Width *2	tWCLH	40	—	ns
CP "L" Pulse Width *2	tWCLL	40	—	ns
CP Rise Up Time *2	trCP	—	30	ns
CP Fall Down Time *2	tfCP	—	30	ns
Data Set Up Time	tDS	30	—	ns
Data Hold Time	tDH	20	—	ns
LOAD "H" Pulse Width	tWLPH	100	—	ns
LOAD "L" Pulse Width	tWLPL	4900	—	ns
LOAD Cycle *3	tLCL	5000	—	ns
CP→LOAD Delay Time	tCL	0	—	ns
LOAD→CP Delay Time *4	tLC	200-tWLPH	—	ns
Input Signal Rise Up Time	tr	—	30	ns
Input Signal Fall Down Time	tf	—	30	ns
FRM Data Set Up Time	tFS	100	—	ns
FRM Data Hold Time	tFH	30	—	ns

*1 CP Cycle is adjust so that FRM signal is 75Hz.

*2 The formula of condition

$$\textcircled{1} \text{ trCP} + \text{tfCP} \leq \text{tCCL} - (\text{tWCLH} + \text{tWCLL})$$

$$\textcircled{2} \text{ trCP}, \text{tfCP} \leq 30 \text{ ns}$$

Please use on condition that $\textcircled{1}$, $\textcircled{2}$ are filled.

*3 LOAD Cycle is const.

*4 $\text{tLC} \geq 0$

12. Supply Voltage Sequence Condition

DO NOT apply DC voltage to the LCD panel. DC voltage induce irreversible electrochemical reactions and reduce LCD life. Always follow the power supply ON/OFF sequence of VDD first, input signal second, VCONT third and finally DISP. This will prevent DC driving of the LCD or CMOS LSI latch up as shown below.

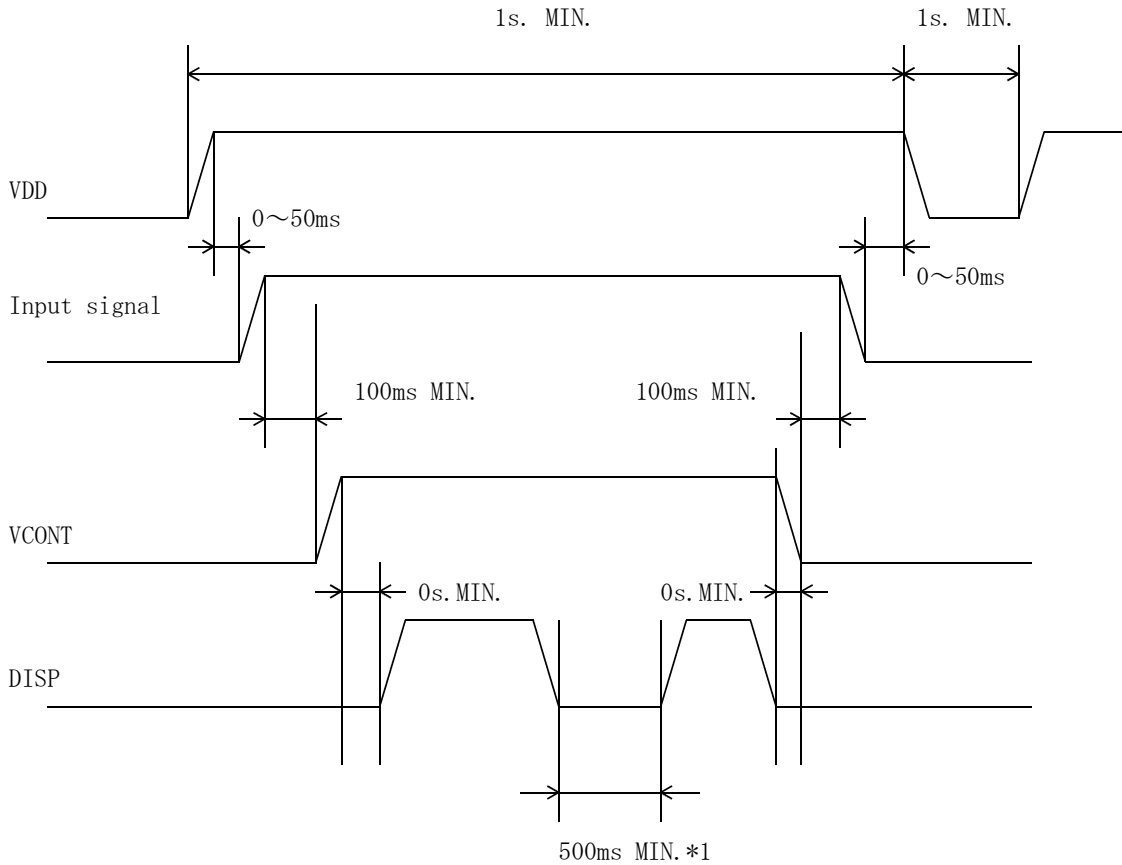

*1 Take interval time for minimum 500ms once you cut off the Disp signal.

* Control the supply voltage sequence not to float all signal line when the LCD panel is driving.

* The above sequence should be designed as to keep each normal figure on condition that LCD module is loaded on your system.

13. Backlight Characteristics

13-1. CFL ratings

Temp. = 25°C

ITEM	SYMBOL	MIN.	TYP.	MAX.	NOTE
Starting discharge Voltage *1	VS	—	—	935 Vrms.	0 °C
		—	—	650 Vrms.	25 °C
Discharging tube current	IL	2.0mArms.	5.0mArms.	6.0mArms.	—
Discharging tube voltage	VL	—	385Vrms.	—	—
Operating life (IL=5.0 mArms.) *2	T	25,000h	40,000h	—	—
Operating frequency	F	20 kHz	—	100 kHz	—

*1 The Non-load output voltage (VS) of the inverter should be designed to have some margin, because VS may increase due to the leak current which may be caused by wiring of CFL cables. (Reference value : (1,216 Vrms MIN.)

*2 When the illuminance or quantity of light has decreased to 50 % of the initial value.

*3 Do not apply more than 6.0mA discharge tube current. Because CFL maybe broken due to over current.

14. Lot Number Identification

The lot number shall be indicated on the back of the backlight case of each LCD.

KHS 0 7 2 VG1MB-L 8 9

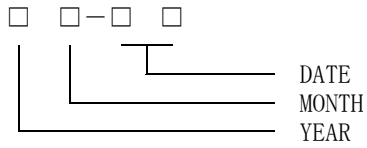

YEAR	2001	2002	2003	2004	2005	2006
CODE	1	2	3	4	5	6

MONTH	JAN.	FEB.	MAR.	APR.	MAY	JUN.
CODE	1	2	3	4	5	6

MONTH	JUL.	AUG.	SEP.	OCT.	NOV.	DEC.
CODE	7	8	9	X	Y	Z

15. Warranty

15-1. Incoming inspection

Please inspect the LCD within one month after your receipt.

15-2. Production Warranty

Kyocera warrants its LCDs for a period of 12 months after receipt by the purchaser, and within the limits specified. Kyocera shall, by mutual agreement, replace or rework defective LCDs that are shown to be Kyocera's responsibility.

16. Precautions for use

16-1. Installation of the LCD

1. Please ground either of the mounting (screw) holes located at each corner of an LCD module, in order to stabilize brightness and display quality.
2. A transparent protection plate shall be added to protect the LCD and its polarizers.
3. The LCD shall be installed so that there is no pressure on the LSI chips.
4. The LCD shall be installed flat, without twisting or bending.
5. The display window size should be the same as the effective viewing area.
6. In case you use outside frame of effective viewing area as outward appearance of your product, unevenness of its outward appearance is out of guarantee.
7. Do not pull the CFL lead wires and do not bend the root of the wires.
Housing should be designed to protect CFL lead wires from external stress.

16-2. Static Electricity

1. Since CMOS ICs are mounted directly onto the LCD glass, protection from static electricity is required. Operation should wear ground straps.

16-3. LCD Operation

1. The LCD shall be operated within the limits specified. Operation at values outside of these limits may shorten life, and/or harm display images.
2. Vop must be adjusted to optimize viewing angle and contrast.
3. Operation of the LCD at temperature below the limit specified may cause image degradation and/or bubbles. It may also change the characteristics of the liquid crystal.
This phenomenon may not recover.
The LCD shall be operated within the temperature limits specified.

16-4. Storage

1. The LCD shall be stored within the temperature and humidity limits specified.
Store in a dark area, and protected the LCD from direct sunlight or fluorescent light.
2. The LCD should be packaged to prevent damage.

16-5. Screen Surface

1. DO NOT store in a high humidity environment for extended periods.
Image degradation, bubbles, and/or peeling off of polarizer may result.
2. The front polarizer is easily scratched or damaged.
Prevent touching it with any hard material, and from being pushed or rubbed.
3. The LCD screen may be cleaned with a soft cloth or cotton pad.
Methanol, or Isopropyl Alcohol may be used, but insure that all solvent residue is removed.
4. Water may cause damage or discoloration of the polarizer.
Clean any condensation or moisture from any source immediately.
5. Always keep the LCD free from condensation during testing.
Condensation may permanently spot or stain the polarizers.

17. Reliability Data / Environmental Test

TEST ITEM	TEST CONDITION	TEST TIME	RESULT
High Temp. Atmosphere	70°C	240 h	Display Quality : No defect Display Function : No defect Current Consumption : No defect
Low Temp. Atmosphere	-20°C	240 h	Low Temp. Bubble : None Solid Crystallization of Liquid Crystal : None Display Quality : No defect Display Function : No defect Current Consumption : No defect
High Temp. Humidity Atmosphere	40°C 90%RH	240 h	Display Quality : No defect Display Function : No defect Peel-off of Organic Sealing : None Current Consumption : No defect
Temp. Cycle	-20°C 0.5 h R. T. 0.5 h 70°C 0.5 h	10 cycles	Display Quality : No defect Display Function : No defect Peel-off of Organic Sealing : None Bubble on Cell : None
High Temp. Operation	50°C Vop	500 h	Display Quality : No defect Current Consumption : No defect

* Each test item uses a test LCD only once. The tested LCD is not used in any other tests.

* The LCD is tested in circumstances in which there is no condensation.

* The tested LCD is inspected after 24 hours of storage at room temperature and room humidity after each test is finished.

* The reliability test is not an out-going inspection.

* The result of the reliability test are for your reference purpose only.
The reliability test is conducted only to examine the LCD's capability.

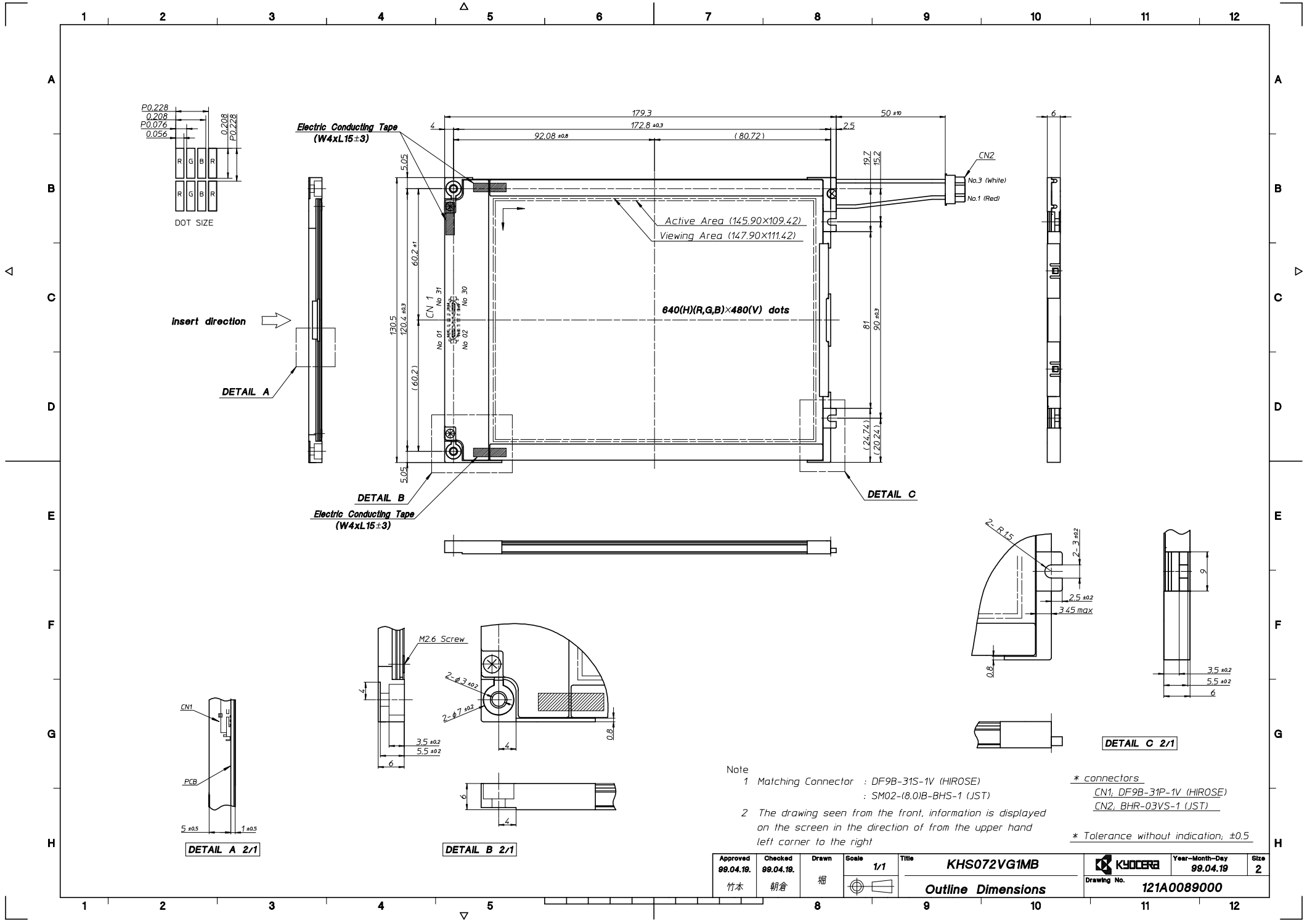

Note

- Matching Connector : DF9B-31S-1V (HIROSE)
 : SM02-(8.0)B-BHS-1 (JST)
- The drawing seen from the front, information is displayed on the screen in the direction of from the upper hand left corner to the right

* connectors
 CN1; DF9B-31P-1V (HIROSE)
 CN2; BHR-03VS-1 (JST)

* Tolerance without indication; ±0.5

Approved 99.04.19. 竹本	Checked 99.04.19. 朝倉	Drawn 堀	Scale 1/1	Title KHS072VG1MB Outline Dimensions	 KYOCERA Drawing No. 121A0089000	Year-Month-Day 99.04.19	Size 2
-----------------------------	----------------------------	------------	--------------	--	--	----------------------------	-----------

Document NO.	TQ3C-8EAC0-E2CWJ09-00
DATE	April 09,2001

FOR :

KYOCERA INSPECTION STANDARD

TYPE : KHS072VG1MB-L89

KYOCERA CORPORATION
KAGOSHIMA HAYATO PLANT
LCD DIVISION

Original	Designed by :Engineering Dept.			Confirmed by :QA Dept.	
Issue Data	Prepared	Checked	Approved	Checked	Approved
April 09,2001	T.Yamasuchi	M.Fujitani	H. Ohno	S. Hayashi	Y. Yoshida

Revision Record

Date	Designed by: Engineering Dept.			Confirmed by: QA Dept.	
	Prepared	Checked	Approved	Checked	Approved
Rev. No.	Date	Page	Descriptions		

Visuals specification

1)Note

Item	Note
General	<p>1. When defects specified in this Inspection Standards are inspected, operating voltage(Vop) shall be set at the level where the defect is observed most clearly. Display quality is applied up to effective viewing area. (Gray-Scale INSPECTION)</p> <p>2. This inspection standard about the image quality shall be applied to any defect within the effective viewing area and shall not be applicable to outside of the area.</p> <p>3. Should any defects which are not specified in this standard happen, additional standard shall be determined by mutual agreement between customer and Kyocera.</p> <p>4. Inspection conditions</p> <p>Luminance : 500 Lux minimum . Inspection distance : 300 mm (from the sample) Temperature : 25 ± 5 °C Direction : right above</p>
Definition of Inspection item	<p>Pinhole, Bright spot Black spot, Scratch Foreign particle</p> <p>The color of a small area is different from the remainder. The phenomenon dose not change with voltage.</p>
	<p>Contrast variation</p> <p>The color of a small area is different from the remainder. The phenomenon changes with voltage.</p>
	<p>Polarizer (Scratch, Bubble, Dent)</p> <p>Scratch, Bubble and Dent in the polarizer which can be observed in on / off state.</p>

2) Standard

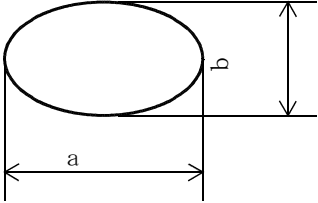
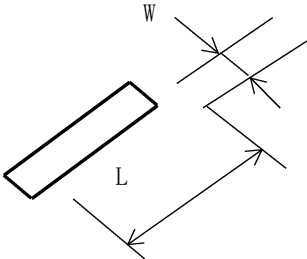
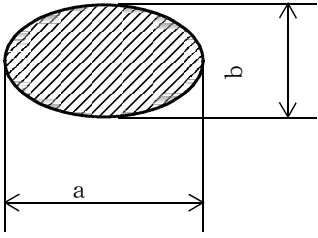
Inspection item	Judgement standard																						
Pinhole, Bright spot Black spot, Foreign particle	<div style="text-align: center;">  $d = (a + b) / 2$ <table border="1" data-bbox="624 577 1385 813"> <thead> <tr> <th>Category</th> <th>Size (mm)</th> <th>Acceptable number</th> </tr> </thead> <tbody> <tr> <td>A</td> <td>$d \leq 0.2$</td> <td>neglected</td> </tr> <tr> <td>B</td> <td>$0.2 < d \leq 0.3$</td> <td>5</td> </tr> <tr> <td>C</td> <td>$0.3 < d \leq 0.5$</td> <td>3</td> </tr> <tr> <td>D</td> <td>$0.5 < d$</td> <td>0</td> </tr> </tbody> </table> </div>	Category	Size (mm)	Acceptable number	A	$d \leq 0.2$	neglected	B	$0.2 < d \leq 0.3$	5	C	$0.3 < d \leq 0.5$	3	D	$0.5 < d$	0							
Category	Size (mm)	Acceptable number																					
A	$d \leq 0.2$	neglected																					
B	$0.2 < d \leq 0.3$	5																					
C	$0.3 < d \leq 0.5$	3																					
D	$0.5 < d$	0																					
Scratch, Foreign particle	<div style="text-align: center;">  <table border="1" data-bbox="595 1137 1414 1440"> <thead> <tr> <th></th> <th>Width (mm)</th> <th>Length (mm)</th> <th>Acceptable No.</th> </tr> </thead> <tbody> <tr> <td>A</td> <td>$W \leq 0.03$</td> <td>—</td> <td>neglected</td> </tr> <tr> <td>B</td> <td rowspan="3">$0.03 < W \leq 0.1$</td> <td>$L \leq 2.0$</td> <td>neglected</td> </tr> <tr> <td>C</td> <td>$2.0 < L \leq 4.0$</td> <td>3</td> </tr> <tr> <td>D</td> <td>$4.0 < L$</td> <td>0</td> </tr> <tr> <td>E</td> <td>$0.1 < W$</td> <td>—</td> <td>According to Circular</td> </tr> </tbody> </table> </div>		Width (mm)	Length (mm)	Acceptable No.	A	$W \leq 0.03$	—	neglected	B	$0.03 < W \leq 0.1$	$L \leq 2.0$	neglected	C	$2.0 < L \leq 4.0$	3	D	$4.0 < L$	0	E	$0.1 < W$	—	According to Circular
	Width (mm)	Length (mm)	Acceptable No.																				
A	$W \leq 0.03$	—	neglected																				
B	$0.03 < W \leq 0.1$	$L \leq 2.0$	neglected																				
C		$2.0 < L \leq 4.0$	3																				
D		$4.0 < L$	0																				
E	$0.1 < W$	—	According to Circular																				
Contrast variation	<div style="text-align: center;">  $d = (a + b) / 2$ <table border="1" data-bbox="624 1787 1385 1977"> <thead> <tr> <th>Category</th> <th>Size (mm)</th> <th>Acceptable number</th> </tr> </thead> <tbody> <tr> <td>A</td> <td>$d \leq 0.5$</td> <td>neglected</td> </tr> <tr> <td>B</td> <td>$0.5 < d \leq 0.7$</td> <td>3</td> </tr> <tr> <td>C</td> <td>$0.7 < d$</td> <td>0</td> </tr> </tbody> </table> </div>	Category	Size (mm)	Acceptable number	A	$d \leq 0.5$	neglected	B	$0.5 < d \leq 0.7$	3	C	$0.7 < d$	0										
Category	Size (mm)	Acceptable number																					
A	$d \leq 0.5$	neglected																					
B	$0.5 < d \leq 0.7$	3																					
C	$0.7 < d$	0																					

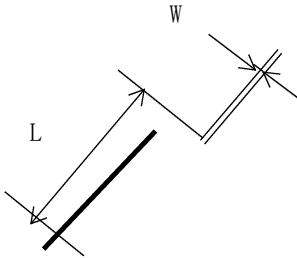
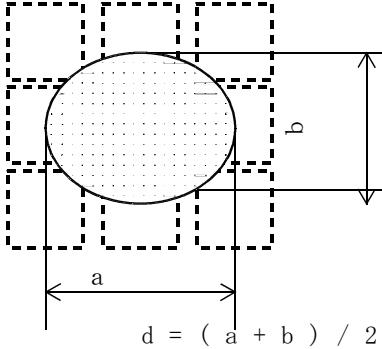
Inspection item	Judgement standard																			
Polarizer (Scratch, Bubble, Dent)	<p data-bbox="584 277 738 304">(1) Scratch</p>  <table border="1" data-bbox="595 672 1412 965"> <thead> <tr> <th></th> <th>Width (mm)</th> <th>Length (mm)</th> <th>Acceptable No.</th> </tr> </thead> <tbody> <tr> <td>A</td> <td>$W \leq 0.1$</td> <td>—</td> <td>neglected</td> </tr> <tr> <td>B</td> <td rowspan="2">$0.1 < W \leq 0.3$</td> <td>$L \leq 5.0$</td> <td>neglected</td> </tr> <tr> <td>C</td> <td>$5.0 < L$</td> <td>0</td> </tr> <tr> <td>D</td> <td>$0.3 < W$</td> <td>—</td> <td>0</td> </tr> </tbody> </table>		Width (mm)	Length (mm)	Acceptable No.	A	$W \leq 0.1$	—	neglected	B	$0.1 < W \leq 0.3$	$L \leq 5.0$	neglected	C	$5.0 < L$	0	D	$0.3 < W$	—	0
	Width (mm)	Length (mm)	Acceptable No.																	
A	$W \leq 0.1$	—	neglected																	
B	$0.1 < W \leq 0.3$	$L \leq 5.0$	neglected																	
C		$5.0 < L$	0																	
D	$0.3 < W$	—	0																	
	<p data-bbox="584 1012 831 1039">(2)Bubble (dent)</p>  <table border="1" data-bbox="624 1554 1383 1848"> <thead> <tr> <th>Category</th> <th>Size (mm)</th> <th>Acceptable number</th> </tr> </thead> <tbody> <tr> <td>A</td> <td>$d \leq 0.2$</td> <td>neglected</td> </tr> <tr> <td>B</td> <td>$0.2 < d \leq 0.3$</td> <td>5</td> </tr> <tr> <td>C</td> <td>$0.3 < d \leq 0.5$</td> <td>3</td> </tr> <tr> <td>D</td> <td>$0.5 < d$</td> <td>0</td> </tr> </tbody> </table>	Category	Size (mm)	Acceptable number	A	$d \leq 0.2$	neglected	B	$0.2 < d \leq 0.3$	5	C	$0.3 < d \leq 0.5$	3	D	$0.5 < d$	0				
Category	Size (mm)	Acceptable number																		
A	$d \leq 0.2$	neglected																		
B	$0.2 < d \leq 0.3$	5																		
C	$0.3 < d \leq 0.5$	3																		
D	$0.5 < d$	0																		