

### AM PULSE NOISE REDUCTION

KIA2051FN is designed for AM stereo pulse noise reduction. The AM stereo pulse noise reduction IC can be easily combined with main tuner RF processor KIA2074F. This IC is very good pulse noise reduction characteristic.

### FUNCTIONS

- IF AGC.
- AF AGC.
- NOISE AGC.
- AM detection.
- Noise amp.
- Operating supply voltage :  $V_{opr}=8\pm 1V$ .
- Pulse noise detection.
- Gate.
- Wave compensation.

### MAXIMUM RATINGS (Ta=25°C)

CHARACTERISTIC	SYMBOL	RATING	UNIT
Supply Voltage	$V_{CC}$	10	V
Power Dissipation (Note)	$P_D$	550	mW
Operating Temperature	$T_{opr}$	-40~85	°C
Storage Temperature	$T_{stg}$	-55~150	°C

Note : Derated above Ta=25°C in the proportion of 4.4mW/°C.

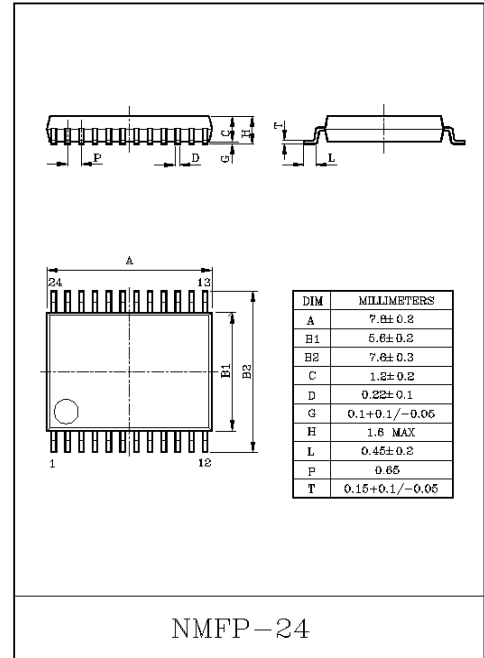

# KIA2051FN

## ELECTRICAL CHARACTERISTICS (Unless otherwise specified, $V_{CC}=8.5V$ , $T_a=25^\circ C$ )

CHARACTERISTIC	SYMBOL	TEST CONDITION	MIN.	TYP.	MAX.	UNIT
Quiescent Current	$I_{CC}$	$V_{IN}=0$	25	35	45	mA
DETECTION						
IF Input Impedance	$Z_{id}$		-	50	-	k $\Omega$
IF Amp. Gain	$G_{VD}$	$f=450kHz$ , $V_{IN}=100\mu V_{rms}(40dB\mu V)$ $f_{mod}=1kHz$ , 100%	51	54	57	dB
IF AGC Level	AGCi	$f=450kHz$ , $V_{IN}=178mV_{rms}(105dB\mu V)$ $f_{mod}=1kHz$ , 100%	-12	-10	-7	dBV
IF Remaining Noise	$v_{ni}$	$V_{IN}=-20dB\mu V$	-	-43	-27.2	dBV
AGC Change Width	AGCW	$f=450kHz$ , $V_{IN}=178mV_{rms}(105dB\mu V)$ $f_{mod}=1kHz$ , 100%	-	-25	-14	dBV
Noise Amp. Gain	$G_{VN}$	$f=15kHz$ , $V_{IN}=1mV_{rms}$	36	39	42	dB
Noise AGC Level	AGCN	$f=15kHz$	-21.2	-18.7	-16.7	dBV
Noise Detection Ratio	P/A	$f=15kHz$	5.5	7.5	9.5	dB
Filter Feed Back Gain	$G_{vf}$	$f=15kHz$	0.4	0.8	1.2	dB
AF AGC Ratio	A'/A	$f=15kHz$	1.8	3.8	5.8	dB
AGC Current	$I_a$		24	30	45	$\mu A$
AGC Current Ratio	$R_{dc}$		-10	-9	-8	-
GATE						
Voltage Gain	$G_v$	$f=400Hz$ , $V_{IN}=400mV_{rms}$	-2.0	-1.0	0.5	dB
Total Harmonic Distortion	THD <sub>0</sub>	$f=400Hz$ , $V_{IN}=700mV_{rms}$	-	0.1	1.0	%
Total Harmonic Distortion	THD <sub>1</sub>	$f=400Hz$ , $V_{IN}=400mV_{rms}$	-	0.05	0.2	%
Sub Gate Voltage Gain	$G_{vS}$	$f=400Hz$ , $V_{IN}=400mV_{rms}$	5	6	7	dB
Compensation Total Harmonic Distortion	THD <sub>2</sub>	$f=400Hz$ , $V_{IN}=400mV_{rms}$ $T_{sw}=0.3mS$ , $T=9mS$	-	2.5	4.0	%
Channel Separation	CS	$f=400Hz$ , $V_{IN}=400mV_{rms}$	50	80	-	dB
Noise Reduction Output	Nr	$T_{sw}=0.3mS$ , $T=9mS$ Din Noise Peak	-	-62.2	-55.2	dBV
Input Impedance	$Z_{ig}$		-	30	-	k $\Omega$
Output Impedance	$Z_{og}$		-	500	-	$\Omega$

# KIA2051FN

## TERMINAL NAME

PIN NO.	SYMBOL	NAME
1	AGC	AGC
2	Det.-out	Detector Output
3	V <sub>cc</sub>	Supply Voltage
4	IF Bypass	IF Amp. Bypass
5	IF in	IF Input
6	GND	Ground
7	AF in 1	Audio Signal Input 1
8	Phase Shift 1	Phase Shifter 1
9	Sub Gate-out 1	Sub Gate Output 1
10	Main Gate-out 1	Main Gate Output 1
11	AFout 1	Noise Cancel Output 1
12	NFB Amp.-out 1	NFB Amp. Output 1
13	NFB Amp.-out 2	NFB Amp. Output 2
14	AFout 2	Noise Cancel Output 2
15	Main Gate-out 2	Main Gate Output 2
16	Sub Gate-out 2	Sub Gate Output 2
17	Phase Shifter 2	Phase Shifter 2
18	AF in 2	Audio Signal Input 2
19	TPW Trimmer	Trigger Pulse Width Control.
20	Filter Amp.-in	Filter Amp. Input
21	Filter Amp. Feed Back	Filter Amp. Feed Back
22	Noise Amp.-out	Noise Amp. Output
23	Noise Amp. Bypass	Noise Amp. Bypass
24	Noise Amp.-in	Noise Amp. Input

# KIA2051FN

## BLOCK DIAGRAM

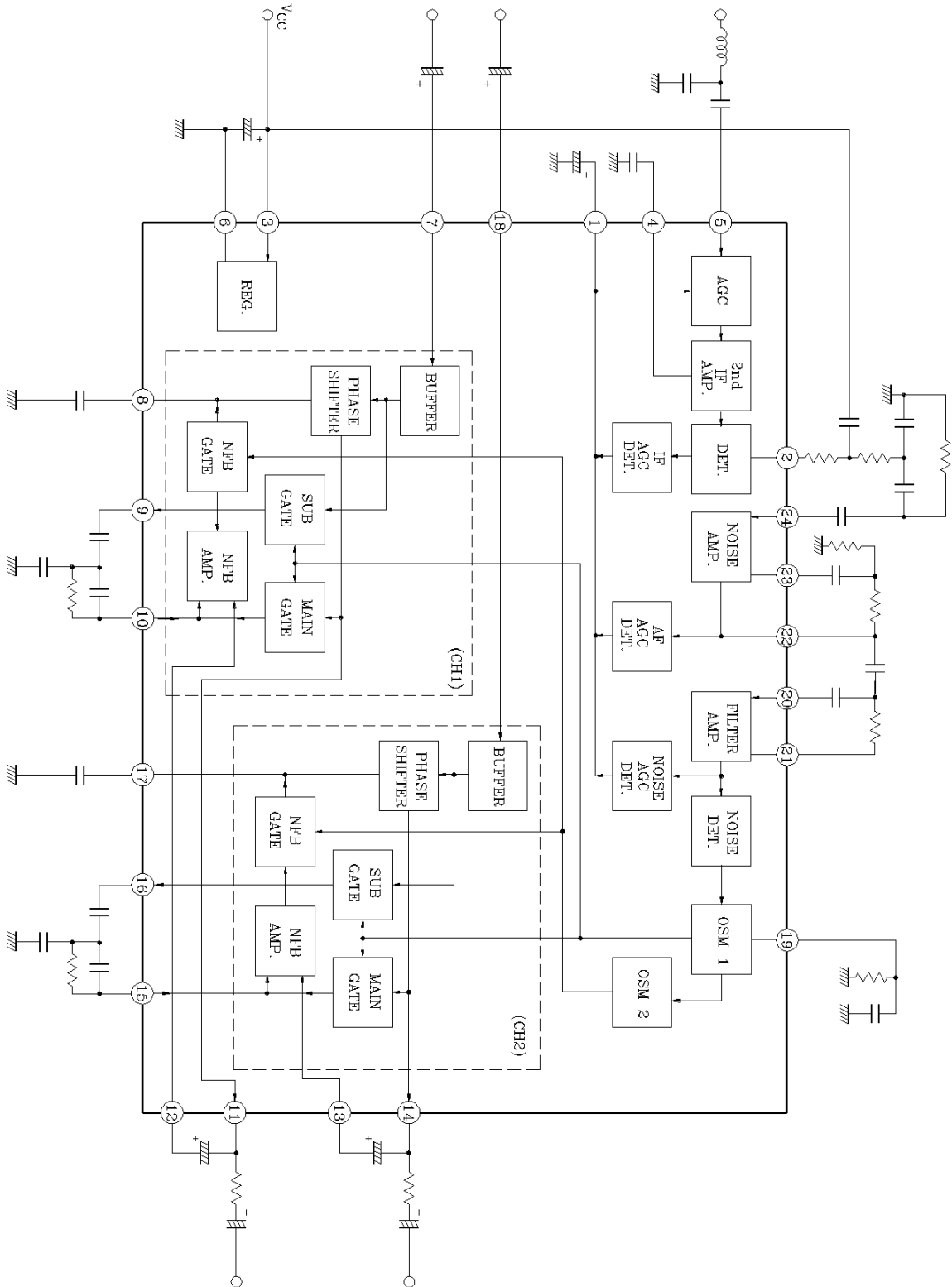

# KIA2051FN

## TEST CIRCUIT

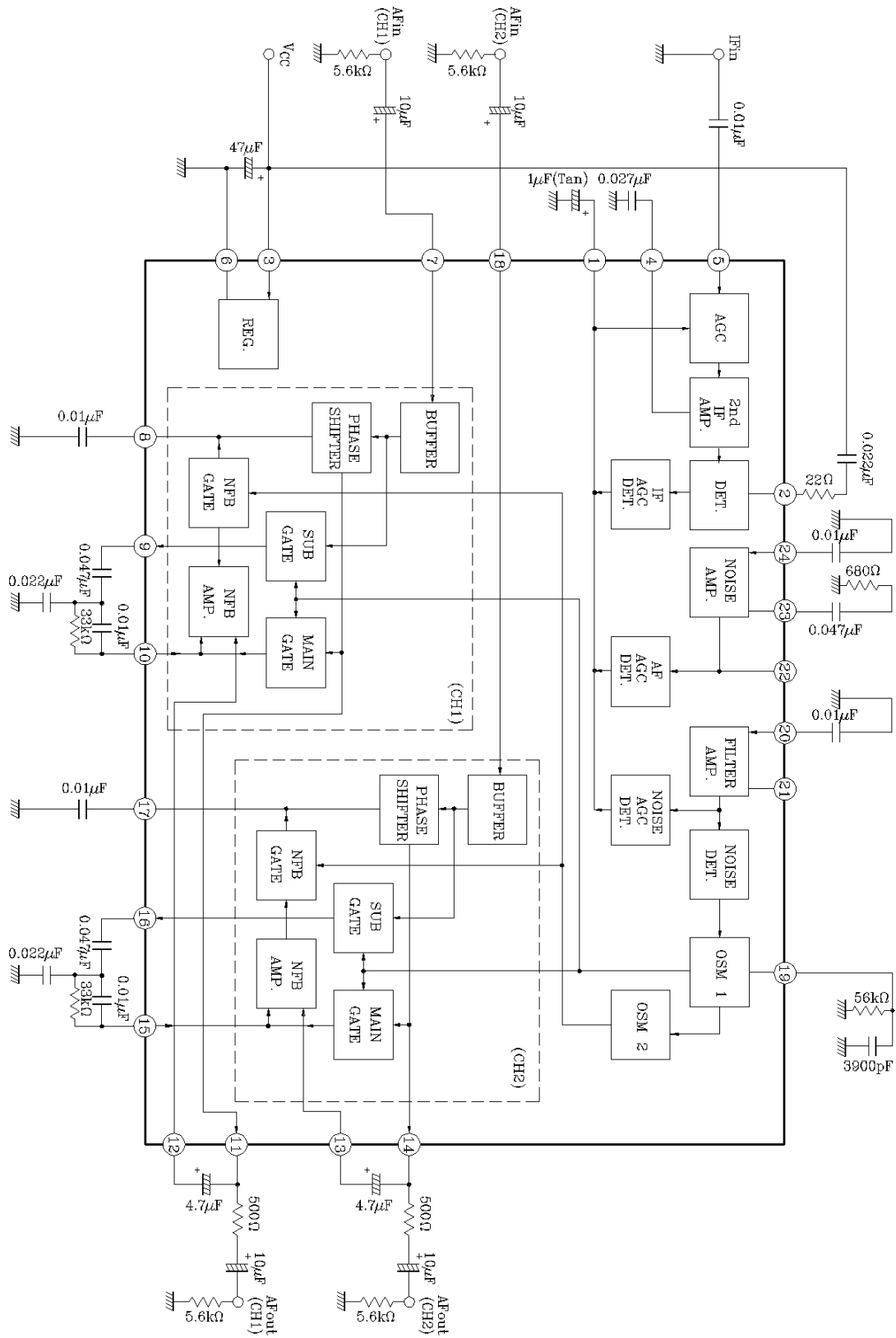

# KIA2051FN

## TEST METHOD

1. Circuit ( $I_{cc}$ ) Fig. 1

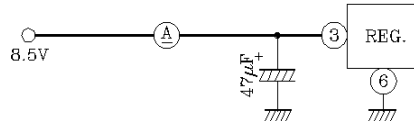

Fig. 1

2. IF impedance ( $Z_{id}$ ) Fig. 2

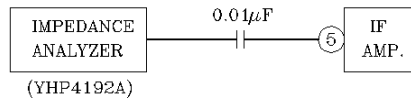

Fig. 2

3. IF Amp. Gain ( $G_{vd}$ ) Fig. 3

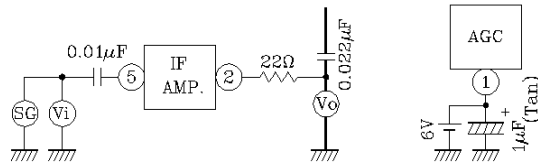

Fig. 3

4. IF AGC Level ( $AGC_i$ ) Fig. 4

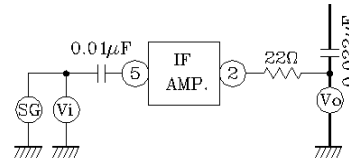

Fig. 4

5. IF Remaining Noise ( $V_{NI}$ ) Fig. 5

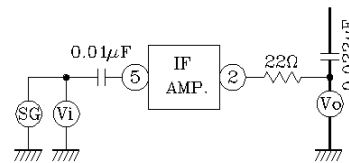

Fig. 5

6. AGC Change Width ( $AGC_w$ ) Fig. 6

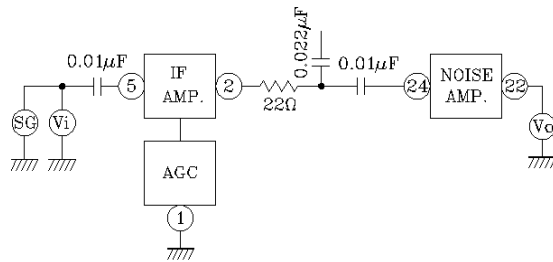

Fig. 6

# KIA2051FN

7. Noise Amp Gain ( $G_{VN}$ ) Fig. 7

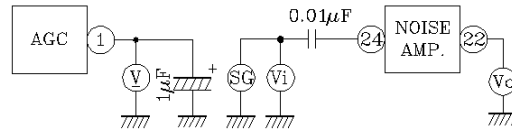

Fig. 7

8. Noise AGC Level ( $AGC_N$ ) Fig. 8

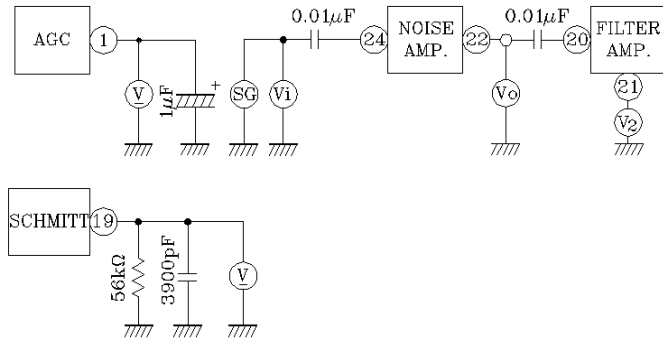

Fig. 8

9. Noise Detection Ratio ( $P/A$ )

$$P/A = V_1' \text{dBV} - AGC_N (=V_1) \text{dBV}$$

$AGC_N$  : Noise AGC Level.  
( $V_1'$ dBV : ② Pin Output Voltage at ① pin in 3V)

10. Filter Feed Back Gain ( $G_{vf}$ )

$$G_{vf} = V_2 \text{dBV} - V_1 \text{dBV}$$

11. AF AGC Ratio ( $A'/A$ )

$$A'/A = V_o' \text{dBV} - AGC_N (=V_1) \text{dBV}$$

$AGC_N$  : Noise AGC Level.

12. AGC Current ( $I_a$ )

at Switch off : Fig. 9

13. AGC Current Ratio ( $R_{dc}$ )

$$R_{dc} = I_a' / I_a \text{ (at switch on : Fig. 9)}$$

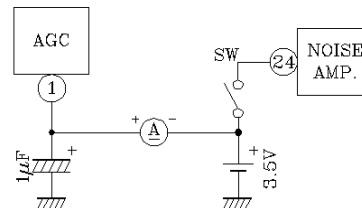

Fig. 9

# KIA2051FN

14. Voltage Gain ( $G_v$ ) Fig. 10

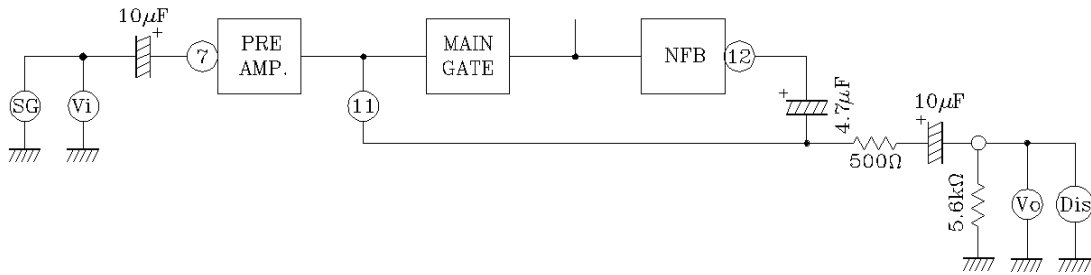

Fig. 10

15. Total Harmonic Distortion ( $\text{THD}_0$ ) Fig. 10

16. Total Harmonic Distortion ( $\text{THD}_1$ ) Fig. 10

17. Sub Gate Voltage Gain ( $G_{vs}$ ) Fig. 11

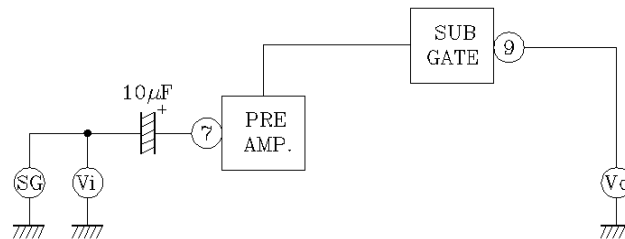

Fig. 11



# KIA2051FN

18. Compensation Total Harmonic Distortion (THD2) Fig. 12

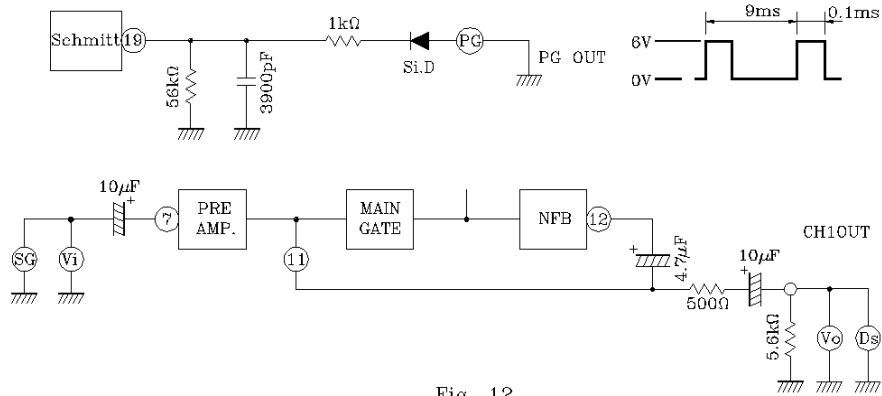

Fig. 12

19. Channel Separation (CS) Fig.13

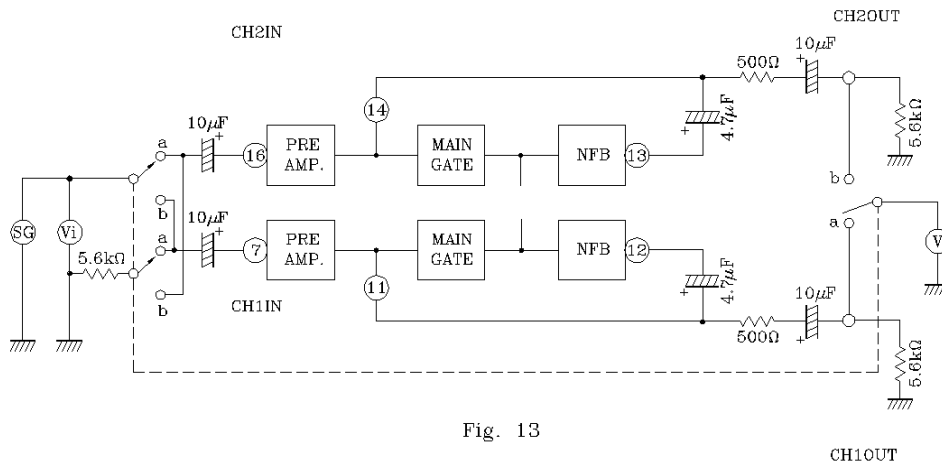

Fig. 13

20. Input Impedance ( $Z_{is}$ ) Fig. 14

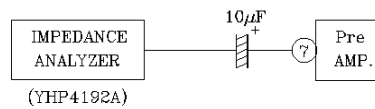

Fig. 14

21. Output Impedance ( $Z_{os}$ ) Fig. 15

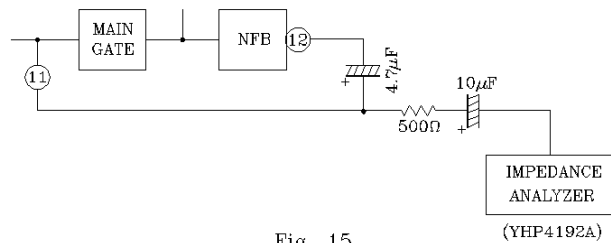

Fig. 15

# KIA2051FN

22. Method of Noise Reduction Output Test. Fig. 16

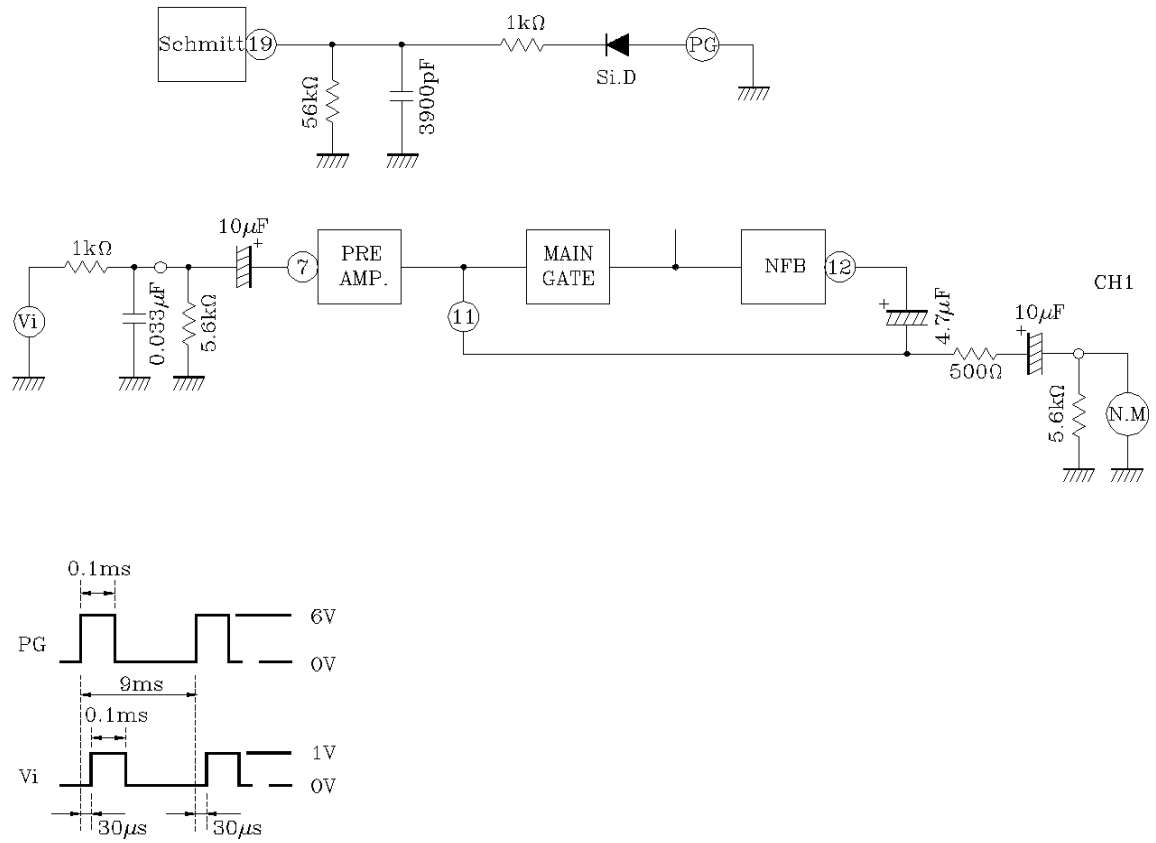

Fig. 16



