

4 TERMINAL 2A OUTPUT LOW DROP VOLTAGE REGULATOR

The KIA278R × × Series are Low Drop Voltage Regulator suitable for various electronic equipments.

It provides constant voltage power source with TO-220-4 terminal lead full molded package. The Regulator has multi function such as over current protection, overheat protection and ON/OFF control.

FEATURES

- 2.0A Output Low Drop Voltage Regulator.
- Built in ON/OFF Control Terminal.
- Built in Over Current Protection, Over Heat Protection Function.
- Suffix U : Qualified to AEC-Q101.

ex) KIA278R**PI-U/PU

LINE UP

ITEM	OUTPUT VOLTAGE (Typ.)	UNIT
KIA278R25PI	2.5	V
KIA278R33PI	3.3	
KIA278R35PI	3.5	
KIA278R05PI	5	
KIA278R06PI	6	
KIA278R08PI	8	
KIA278R09PI	9	
KIA278R10PI	10	
KIA278R12PI	12	
KIA278R15PI	15	

MAXIMUM RATINGS (Ta=25)

CHARACTERISTIC	SYMBOL	RATING	UNIT	Remark
Input Voltage	V_{IN}	35	V	-
ON/OFF Control Voltage	V_C	35	V	-
Output Current	I_O	2	A	-
Power Dissipation 1	P_{d1}	1.5	W	No heatsink
Power Dissipation 2	P_{d2}	15	W	with heatsink
Operating Junction Temperature	$T_{J(opr)}$	-40 150		-
Storage Temperature	T_{stg}	-45 150		-
Soldering Temperature (10sec)	T_{sol}	260		-

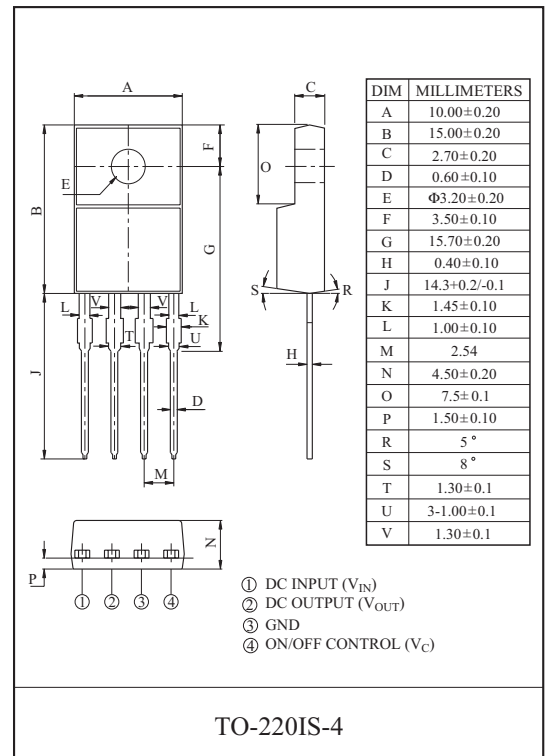

KIA278R05PI~KIA278R35PI

ELECTRICAL CHARACTERISTICS (Unless otherwise specified, $I_O=1.0A$, $T_a=25$, Note1.)

CHARACTERISTIC	SYMBOL	CONDITIONS	MIN.	TYP.	MAX.	UNIT
Output Voltage	KIA278R25	-	2.438	2.50	2.562	V
	KIA278R33	-	3.22	3.30	3.38	
	KIA278R35	-	2.413	3.50	3.587	
	KIA278R05	-	4.88	5.0	5.12	
	KIA278R06	-	5.85	6.0	6.15	
	KIA278R08	-	7.80	8.0	8.2	
	KIA278R09	-	8.78	9.0	9.22	
	KIA278R10	-	9.75	10.0	10.25	
	KIA278R12	-	11.70	12.0	12.30	
KIA278R15	-	14.70	15.0	15.30		
Load Regulation	Reg Load	$I_O=5mA$ 2A	-	0.1	2.0	%
Line Regulation	Reg Line	(Note 2)	-	0.5	2.5	%
Temperature Coefficient of Output Voltage	$T_C V_O$	$T_j=0$ 125	-	± 0.02	± 0.05	%/
Ripple Rejection	$R \cdot R$	-	45	55	-	dB
Drop Out Voltage	V_D	$I_O=2A$	-	-	0.5	V
Output ON state for control Voltage	$V_{C(ON)}$	-	2.0	-	-	V
Output ON state for control Current	$I_{C(ON)}$	$V_C=2.7V$	-	-	20	μA
Output OFF state for control Voltage	$V_{C(OFF)}$	-	-	-	0.8	V
Output OFF state for control Current	$I_{C(OFF)}$	$V_C=0.4V$	-	-	-0.4	mA
Quiescent Current	I_Q	$I_O=0$	-	-	10	mA

Note1) V_{IN} of KIA278R25=4.2V Note2) V_{IN} of KIA278R25=3.2 10V Note3) At $V_{IN}=0.95V_O$

- | | | |
|------------------|---------------------|--|
| " KIA278R33=5.0V | " KIA278R33=4.0 10V | |
| " KIA278R35=5.2V | " KIA278R35=4.2 10V | |
| " KIA278R05=7V | " KIA278R05=6 12V | |
| " KIA278R06=8V | " KIA278R06=7 15V | |
| " KIA278R08=10V | " KIA278R08=9 25V | |
| " KIA278R09=15V | " KIA278R09=10 25V | |
| " KIA278R10=16V | " KIA278R10=11 26V | |
| " KIA278R12=18V | " KIA278R12=13 29V | |
| " KIA278R15=21V | " KIA278R15=16 32V | |

BLOCK DIAGRAM

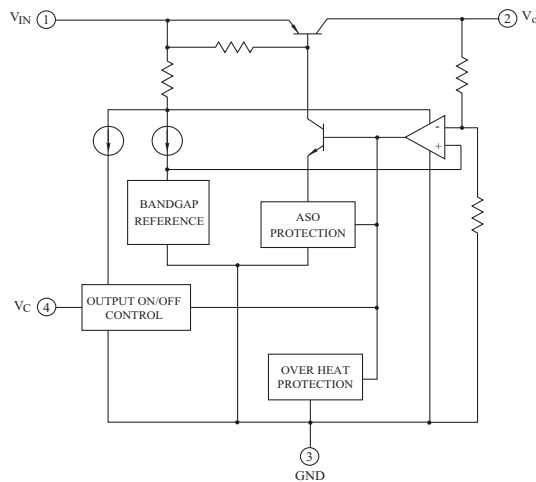

KIA278R05PI~KIA278R35PI

Fig. 1 Standard Test Circuit

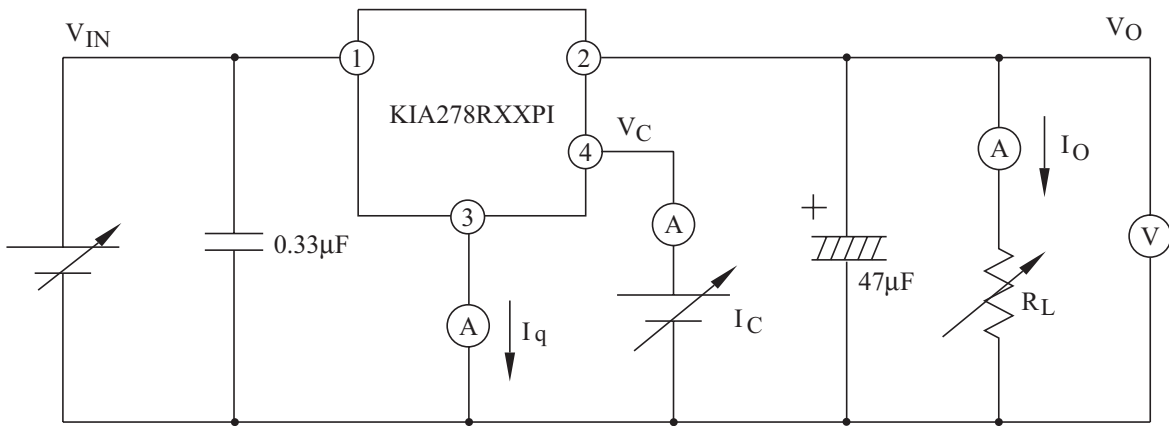

Fig. 2 Ripple Rejection Test Circuit

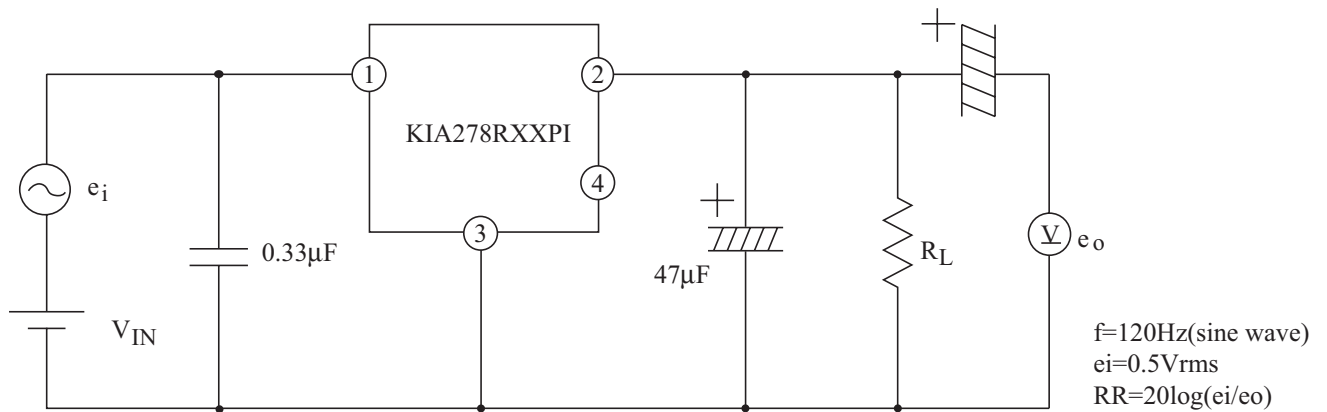
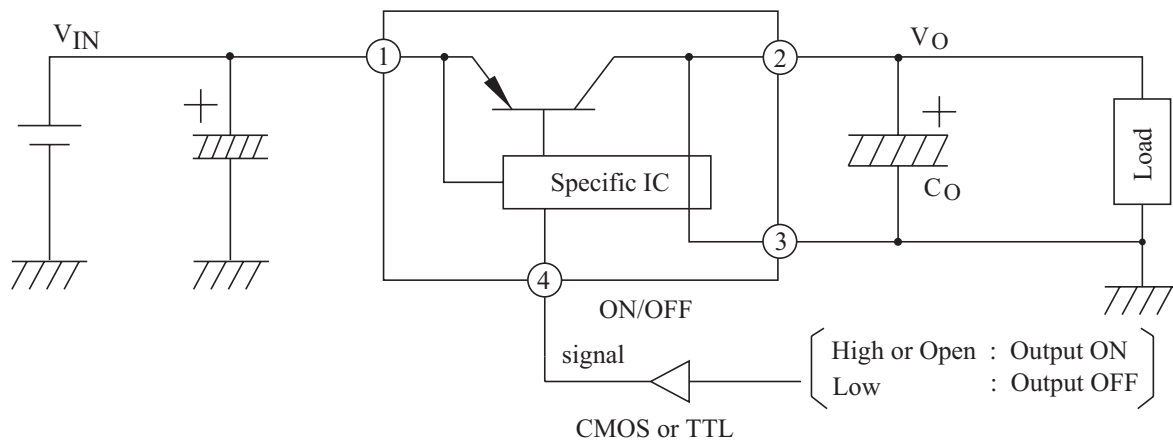

Fig. 3 Application Circuit for Standard



KIA278R05PI~KIA278R35PI

Fig.4 $P_D - T_a$

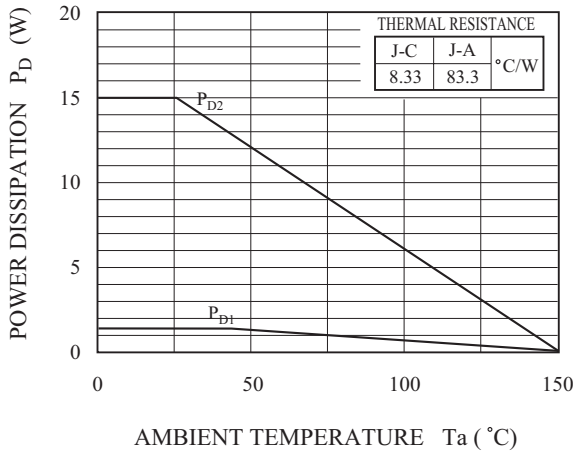

Fig.5 $I_O - V_O$

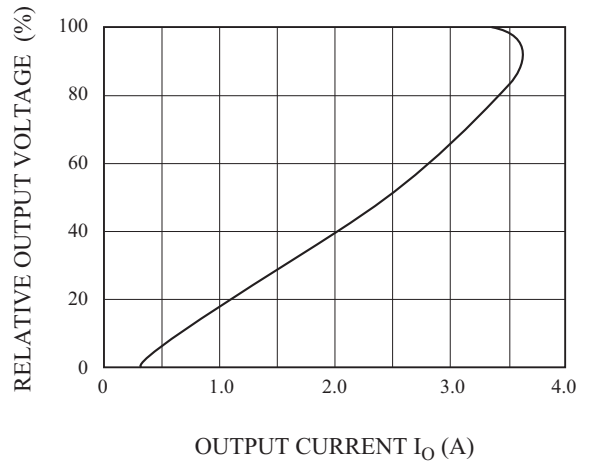

Fig. 6 $\Delta V_O - T_j$

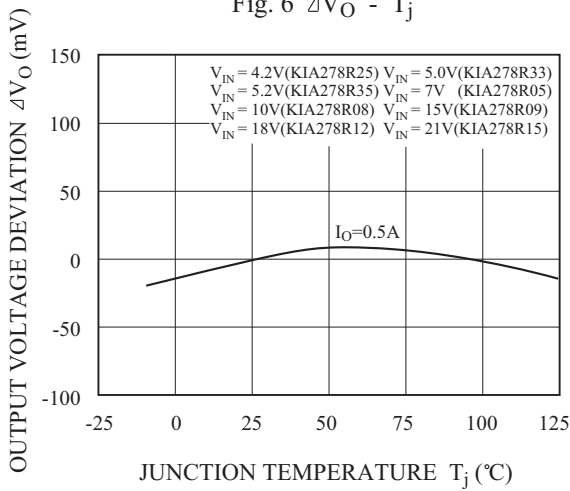

Fig.7 $V_{IN} - V_O$ (KIA278R05)

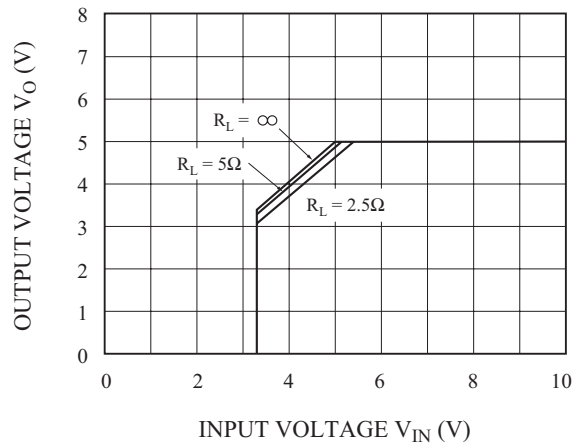

Fig.8 $V_{IN} - V_O$ (KIA278R08)

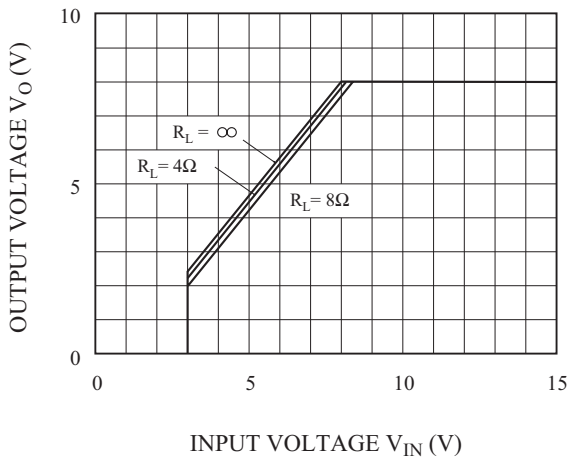
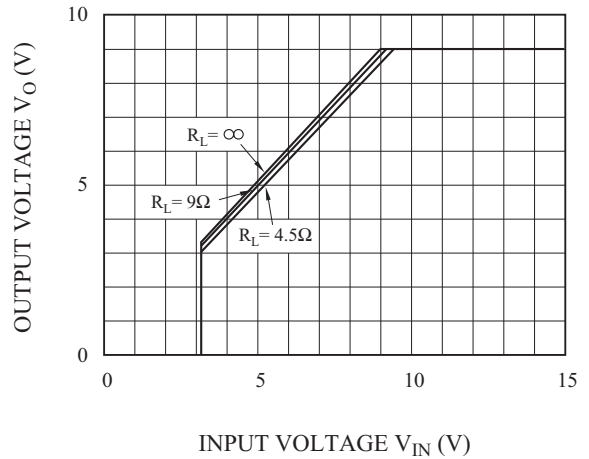

Fig.9 $V_{IN} - V_O$ (KIA278R09)



KIA278R05PI~KIA278R35PI

Fig.10 $V_{IN} - V_O$ (KIA278R12)

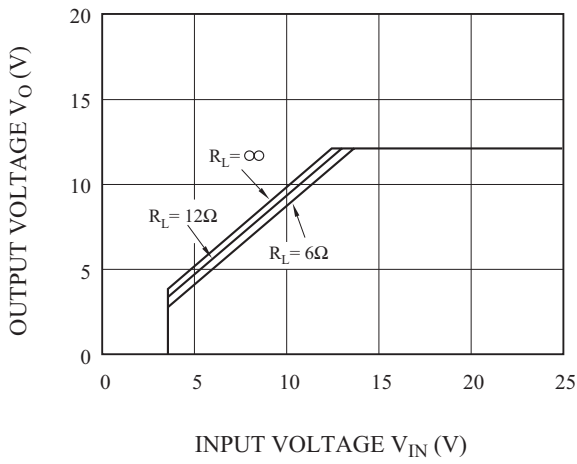

Fig.11 $V_{IN} - V_O$ (KIA278R15)

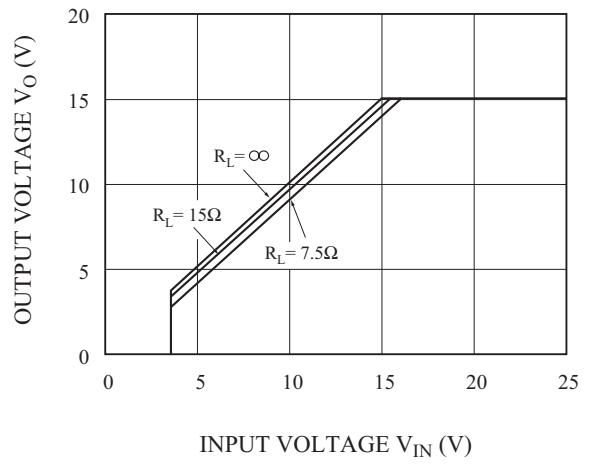

Fig.12 $V_{IN} - I_{BIAS}$ (KIA278R05)

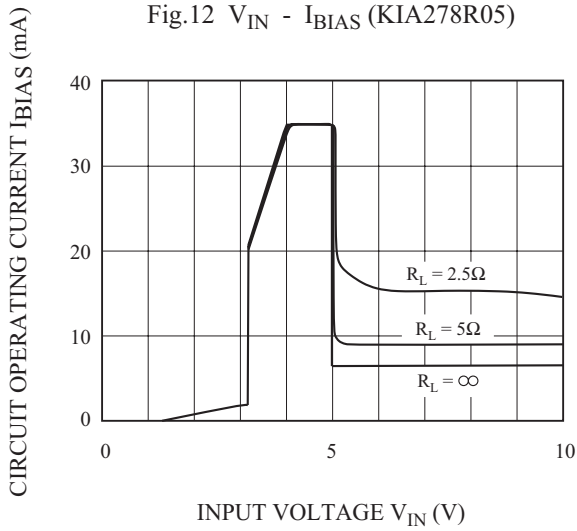

Fig.13 $V_{IN} - I_{BIAS}$ (KIA278R08)

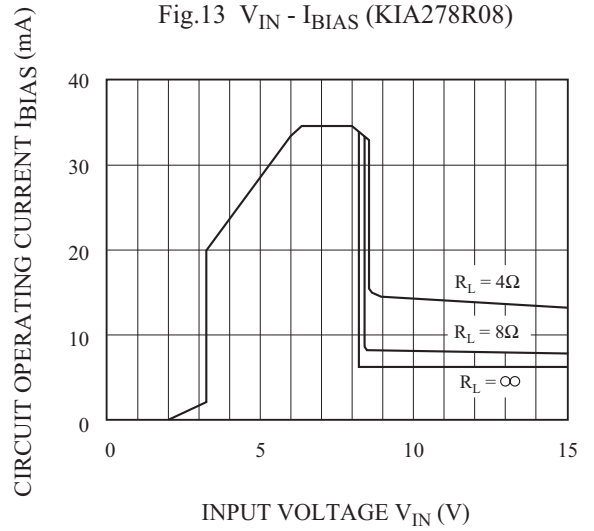

Fig.14 $V_{IN} - I_{BIAS}$ (KIA278R09)

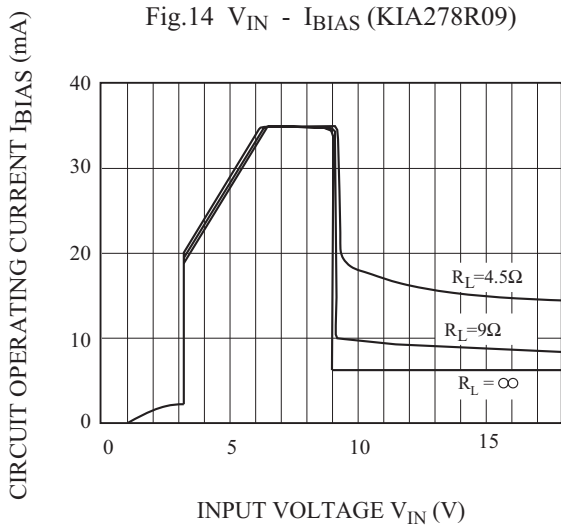
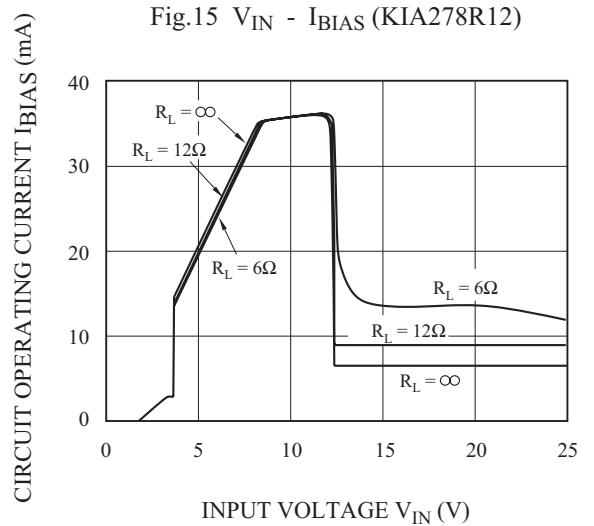

Fig.15 $V_{IN} - I_{BIAS}$ (KIA278R12)



KIA278R05PI~KIA278R35PI

Fig.16 $V_{IN} - I_{BIAS}$ (KIA278R15)

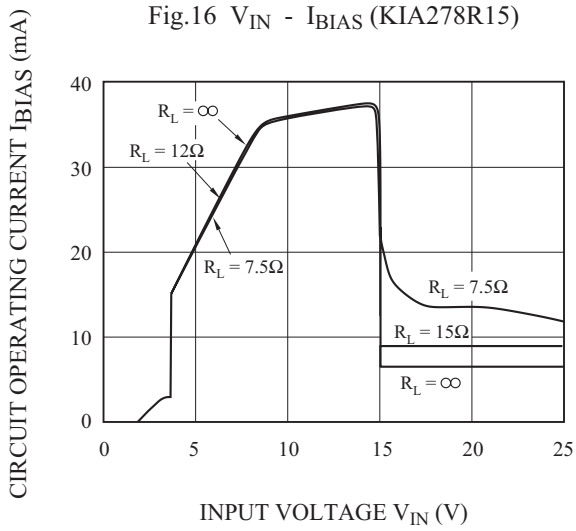

Fig.17 $T_j - V_D$

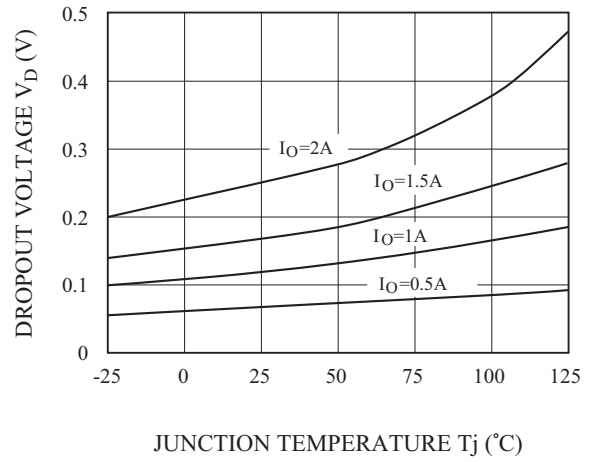

Fig.18 $T_j - I_q$

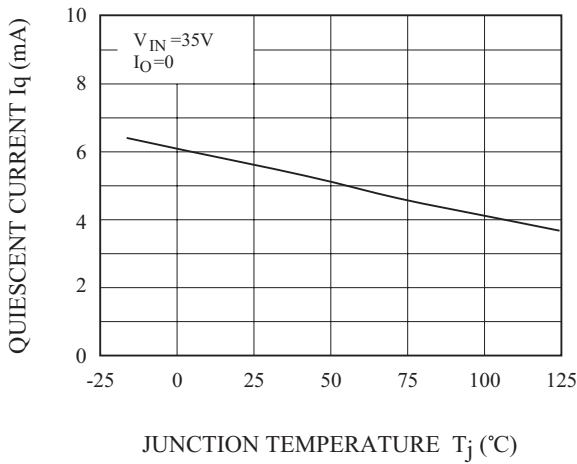

Fig. 19 R.R - f

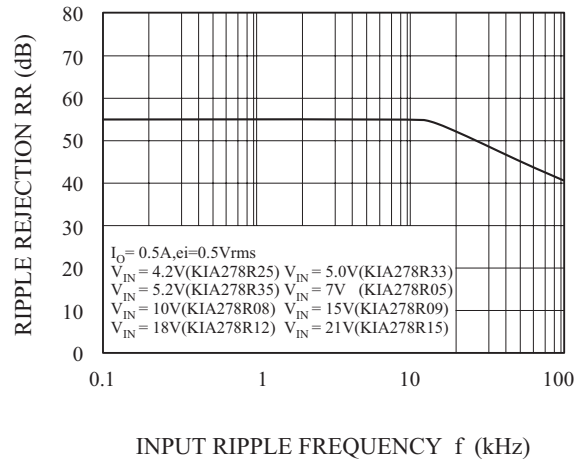

Fig.20 $I_O - RR$

