

LOW NOISE DUAL PRE-AMPLIFIER

The KIA6259P and KIA6259S are dual low noise pre-amplifier improved on operational amplifier(4558type) for consumer applications.

FEATURES

- Wide operating supply voltage range
: $V_{CC}, V_{EE} \pm 1.5V \sim \pm 18.0V$
- Low Noise, Low Distortion
: $V_{NI} = 1 \mu V_{rms}$ (Typ.)
($R_g = 2.2k\Omega$, NAB , $f = 1kHz$, $G_v = 40dB$)
: $THD = 0.005\%$, ($V_{OUT} = 2.0V_{rms}$)
- The recommended closed loop voltage gain in more than 20dB.

MAXIMUM RATING (Ta=25°C)

CHARACTERISTIC	SYMBOL	RATING	UNIT
Supply Voltage	V_{CC}	± 22	V
Power Dissipation (Note)	KIA6259P	500	mW
	KIA6259S	750	
Operating Temperature	T_{opr}	-25 ~ 75	°C
Storage Temperature	T_{stg}	-55 ~ 150	°C

Note : Derated about $T_a = 25^\circ C$ in the proportion of $4mW/^\circ C$ for KIA6259P, and of $6mW/^\circ C$ for KIA6259S.

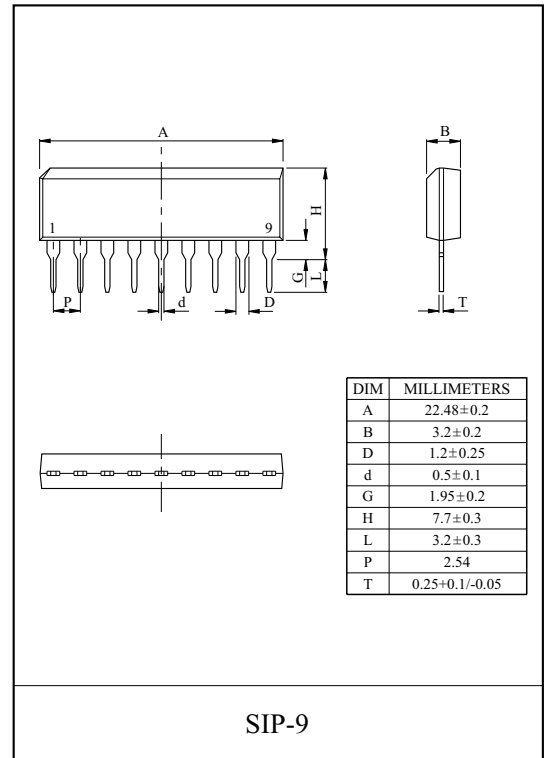
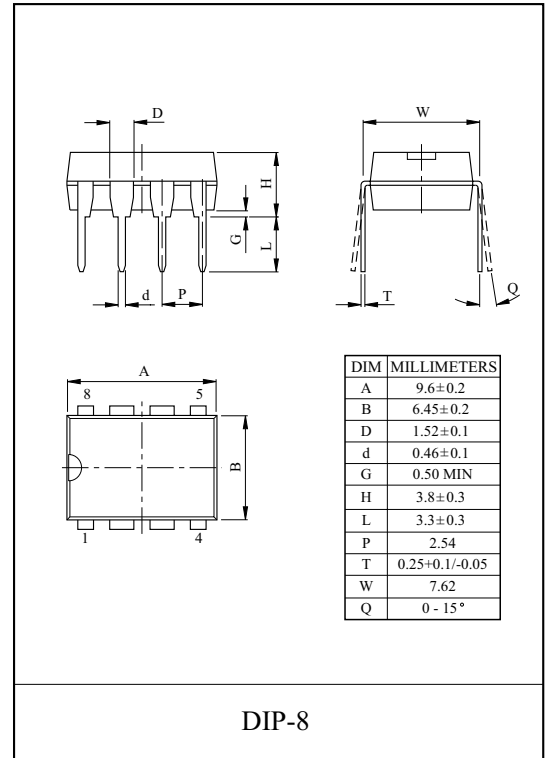

KIA6259P/S

PIN CONNECTION (TOP VIEW)

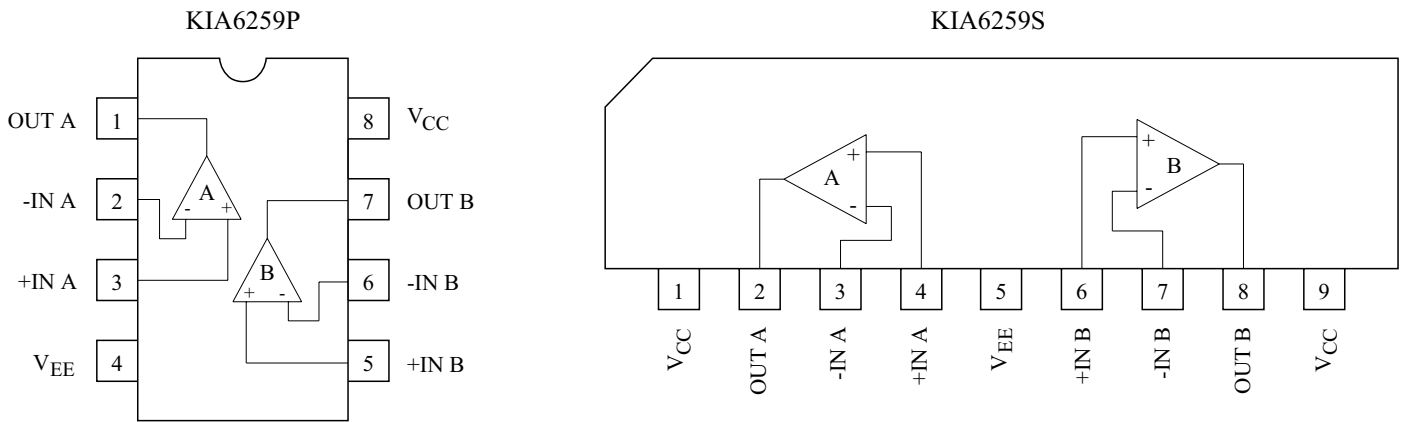

ELECTRICAL CHARACTERISTICS (Ta=25 °C)

(Unless otherwise specified, V_{CC}=4.5V, V_{EE}=-4.5V, f=1kHz, Ta=25 °C)

CHARACTERISTIC	SYMBOL	TEST CIRCUIT	TEST CONDITION	MIN.	TYP.	MAX.	UNIT
Quiescent Current	I _{CCQ}	1	V _{IN} =0	-	2.7	4.0	mA
Equivalent Input Noise Voltage	V _{NI}	1	R _g =2.2kΩ, NAB, G _V =40dB BW=20Hz ~20kHz	-	1.0	1.3	μV _{rms}
Open Loop Voltage Gain	G _{VO}	1	V _{OUT} =2.0V _{rms}	75	85	-	dB
Total Harmonic distortion	THD	1	V _{OUT} =2.0V _{rms}	-	0.005	0.01	%
Maximum Output Voltage	V _{OM}	1	THD=0.5%	2.0	2.7	-	V _{rms}
Cross Talk	C.T.	1	R _g =2.2kΩ, V _{OUT} =2.0V _{rms}	65	76	-	dB
Input Bias Current	I _{IB}	1	-	-	0.65	-	μA

DC CHARACTERISTICS

(V_{CC}=4.5V, V_{EE}=-4.5V, R_g=2.2kΩ, Terminal Voltage at No Signal)

(Unit in mV)

TERMINAL NO.	1	2	3	4	5	6	7	8	9
KIA6259S	V _{CC}	15	75	75	V _{EE}	75	75	15	V _{CC}
KIA6259P	15	75	75	V _{EE}	75	75	75	V _{CC}	-

KIA6259P/S

TEST CIRCUIT

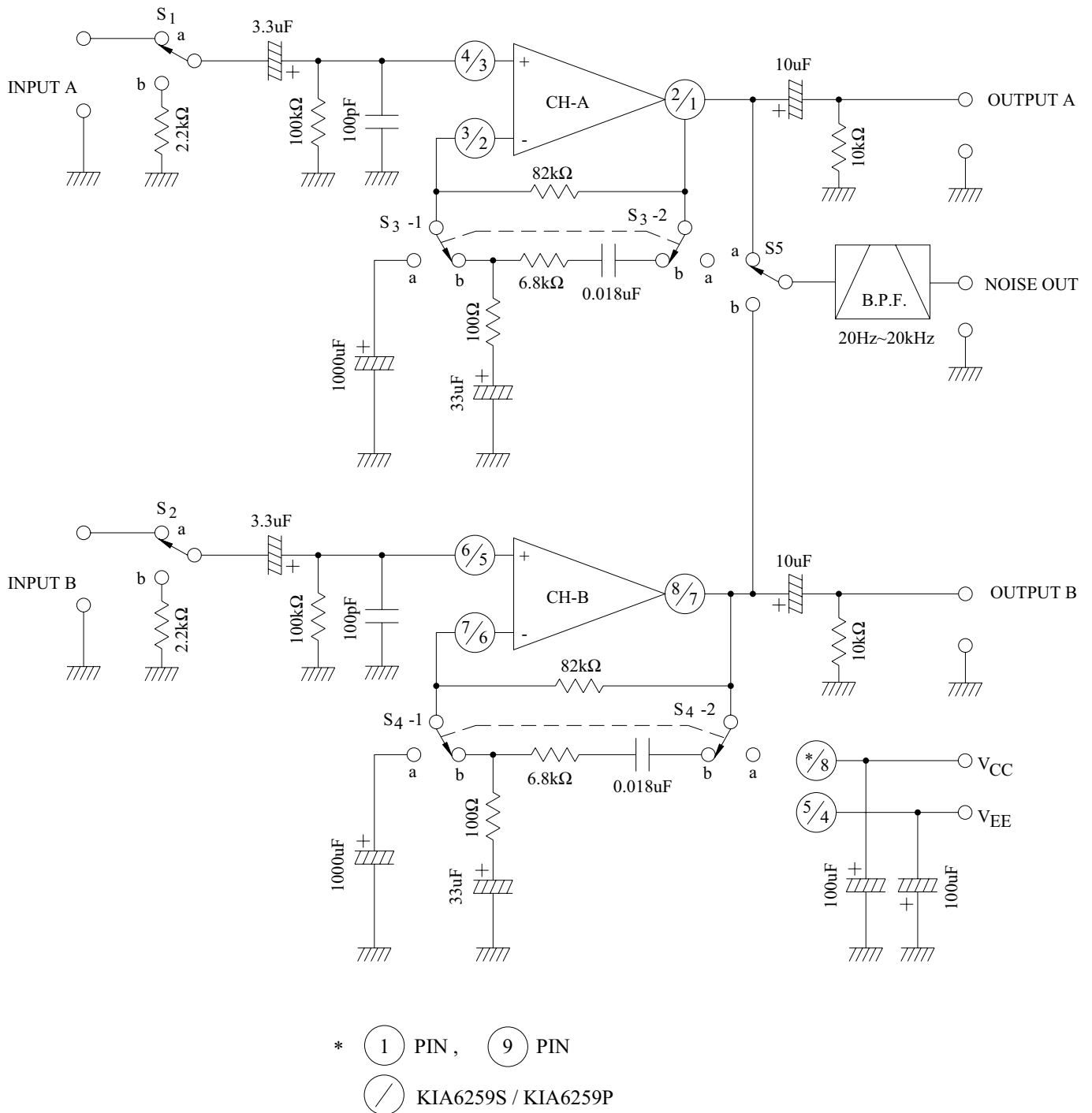

KIA6259P/S

EQUIVALENT CIRCUIT

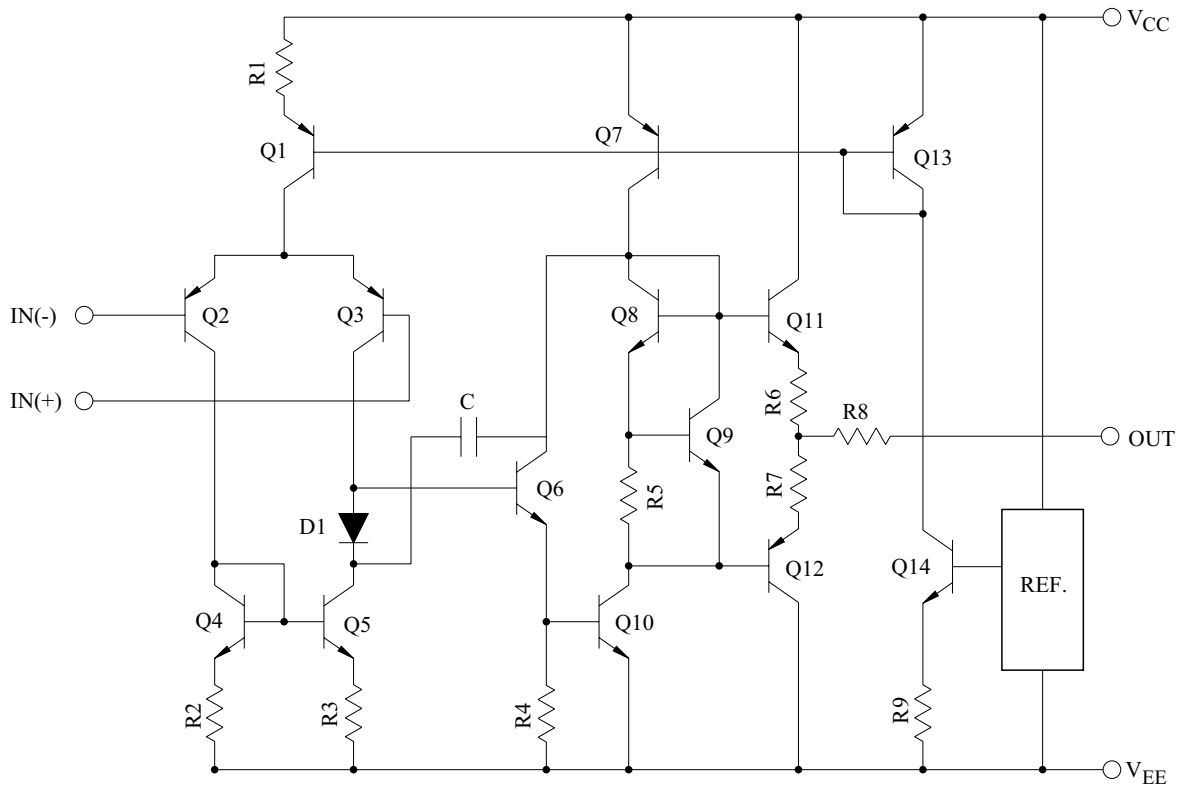

KIA6259P/S

APPLICATION CIRCUITS

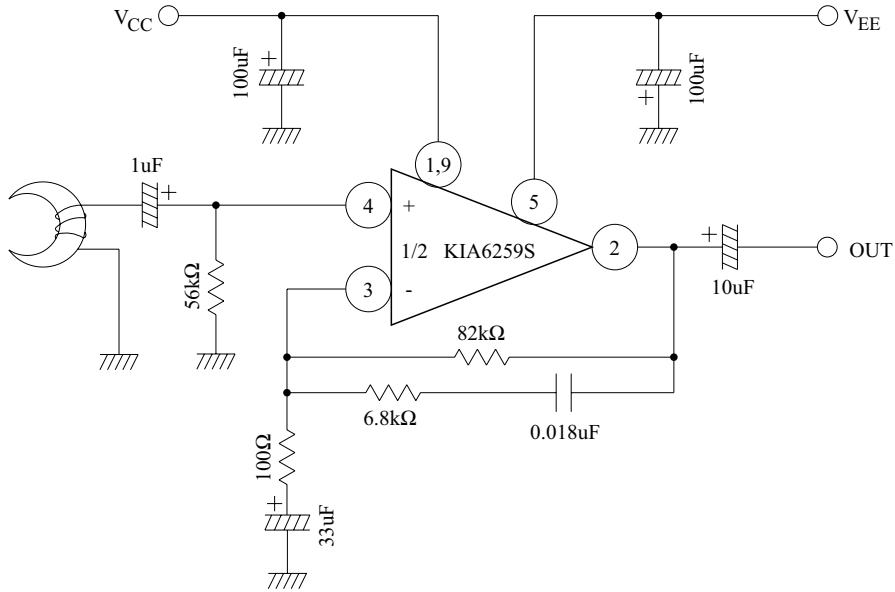

$G_{VO} - f$

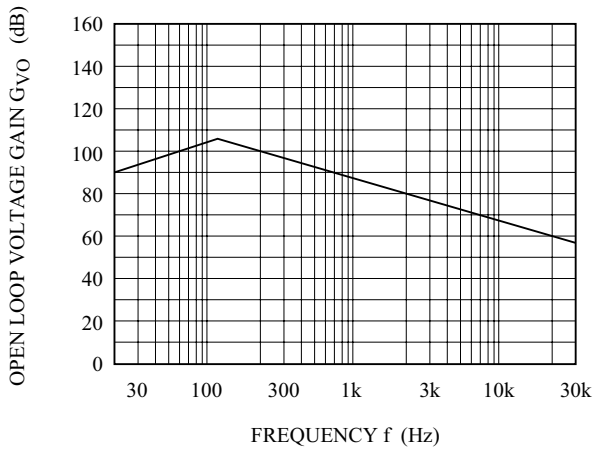

$G_V - f$

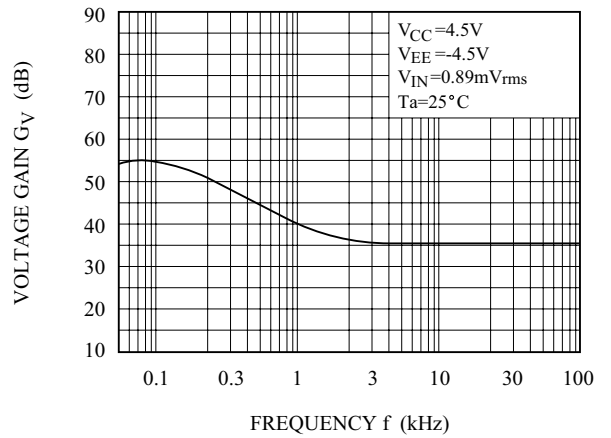

$V_{NI} - R_g$

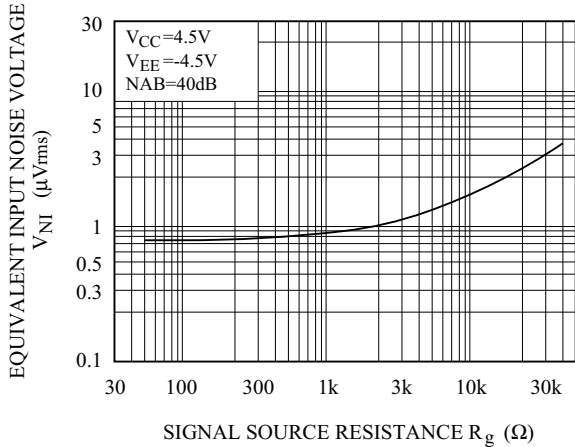

C.T - f

